

**RIGHT ANGLE H3 RECEPTACLE SMT TYPE**

**R107.303.040**

**BOBINE 100**

Series : UMP

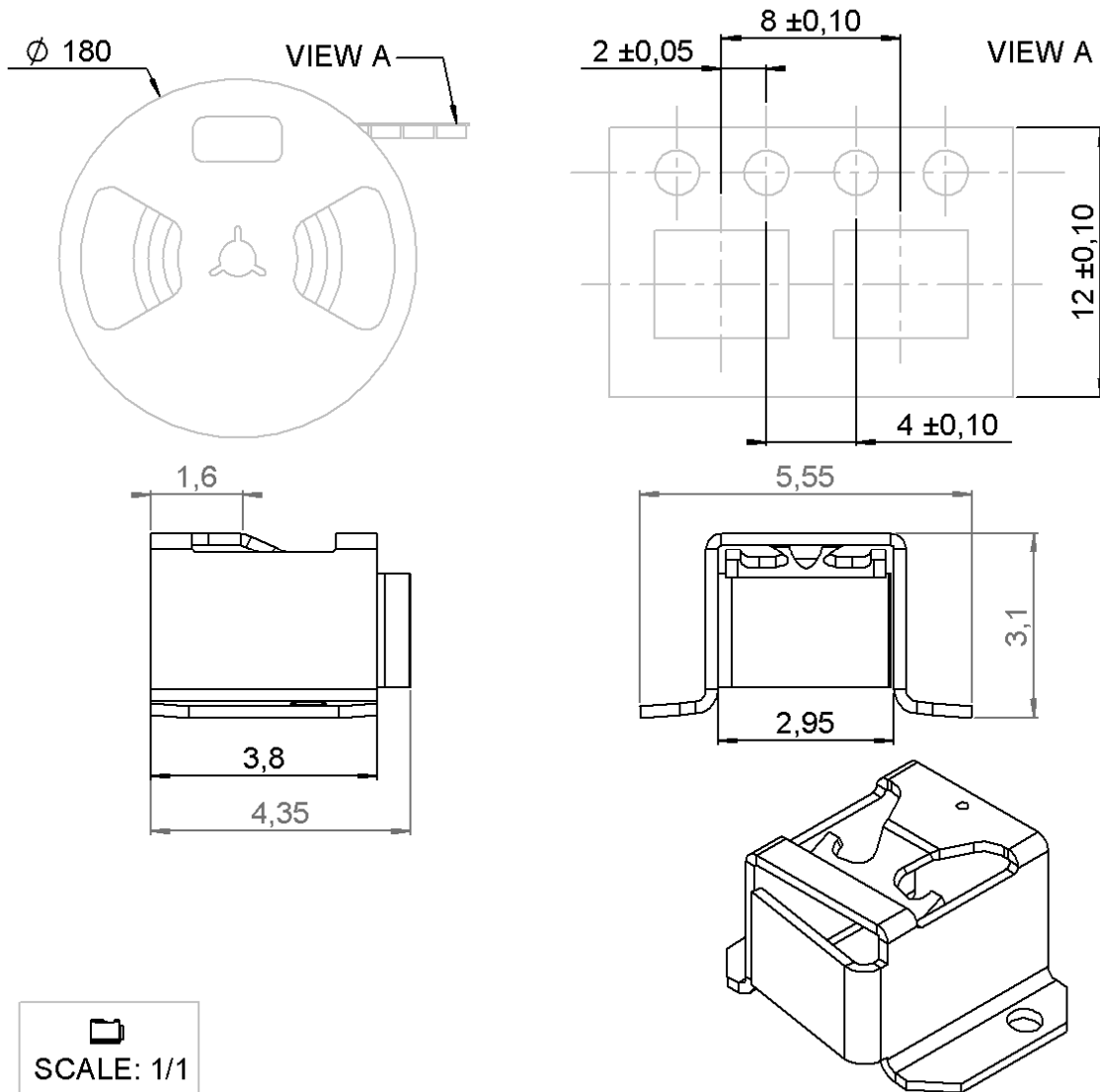

 SCALE: 1/1

All dimensions are in mm.

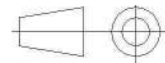

COMPONENTS	MATERIALS	PLATINGS (µm)
BODY	BERYLLIUM COPPER	GOLD 0.2 OVER NICKEL 2
CENTER CONTACT	-	-
OUTER CONTACT	-	-
INSULATOR	-	-
GASKET	-	-
OTHERS PARTS	-	-
-	-	-
-	-	-

Issue : 1213 C

In the effort to improve our products, we reserve the right to make changes judged to be necessary.



**RIGHT ANGLE H3 RECEPTACLE SMT TYPE**

**R107.303.040**

**BOBINE 100**

Series : UMP

**PACKAGING**

**SPECIFICATION**

Standard	Unit	Other
<b>100</b>	<b>'W' option</b>	<b>Contact us</b>

**ELECTRICAL CHARACTERISTICS**

**ENVIRONMENTAL**

Impedance	<b>50</b>	$\Omega$
Frequency	<b>0-6</b>	GHz
VSWR	<b>1.05 + 0,0300</b>	x F(GHz) Maxi
Insertion loss	<b>NA</b>	$\sqrt{F}$ (GHz) dB Maxi
RF leakage	<b>NA</b>	- F(GHz)) dB Maxi
Voltage rating	<b>100</b>	Veff Maxi
Dielectric withstanding voltage	<b>350</b>	Veff mini
Insulation resistance	<b>1000</b>	M $\Omega$ mini

Operating temperature	<b>-40/+125</b>	$^{\circ}$ C
Hermetic seal	<b>NA</b>	Atm.cm3/s
Panel leakage	<b>NA</b>	

**OTHERS CHARACTERISTICS**

Assembly instruction

Others :

**MECHANICAL CHARACTERISTICS**

Center contact retention		
Axial force – Mating end	-	N mini
Axial force – Opposite end	-	N mini
Torque	-	N.cm mini
Recommended torque		
Mating	-	N.cm
Panel nut	-	N.cm
Mating life	<b>50</b>	Cycles mini
Weight	<b>0,0600</b>	g

Issue : 1213 C

In the effort to improve our products, we reserve the right to make changes judged to be necessary.



**RIGHT ANGLE H3 RECEPTACLE SMT TYPE**

**R107.303.040**

**BOBINE 100**

Series : UMP

**SOLDER PROCEDURE OF UMP RECEPTABLE  
IN INDUSTRIAL ENVIRONMENT**

1. Deposit solder paste 'Sn Ag4 Cu0.5' on mounting zone by screen printing application. We recommend a low residue flux.  
We advise a thickness of 150 micromm ( 5.850 microinch ). Verify that the edges of the zone are clean.
2. Placement of the receptacle on the mounting zone with an automatic machine of 'pick and place' type. A video camera is recommended for positioning of the component . Adhesive agents must not be used on the receptacle.
3. This process of soldering has been tested with convection oven .Below please find ,the typical profile to use.
4. The cleaning of printed circuit boards is not obliged .
5. Verification of solder joints and position of the component by visual inspection.

NOTE : The UMP receptacle and the UMP plug must not be mated before completion of this procedure

**TEMPERATURE PROFILE**

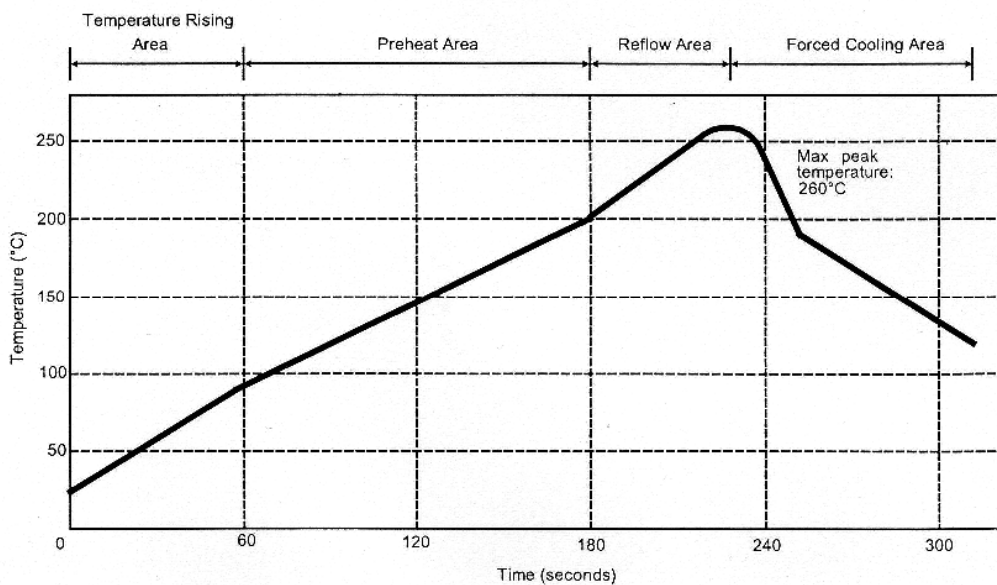

Parameter	Value	Unit
Temperature rising Area	1 - 4	°C/sec
Max Peak Temperature	260	°C
Max dwell time @260°C	10	sec
Min dwell time @235°C	20	sec
Max dwell time @235°C	60	sec
Temperature drop in cooling Area	-1 to - 4	°C/sec
Max dwell time above 100°C	420	sec

Issue : 1213 C

In the effort to improve our products, we reserve the right to make changes judged to be necessary.



**RIGHT ANGLE H3 RECEPTACLE SMT TYPE**

**R107.303.040**

**BOBINE 100**

Series : UMP



# UMP SERIES INFORMATION

## PCB

### COPLANAR LINE

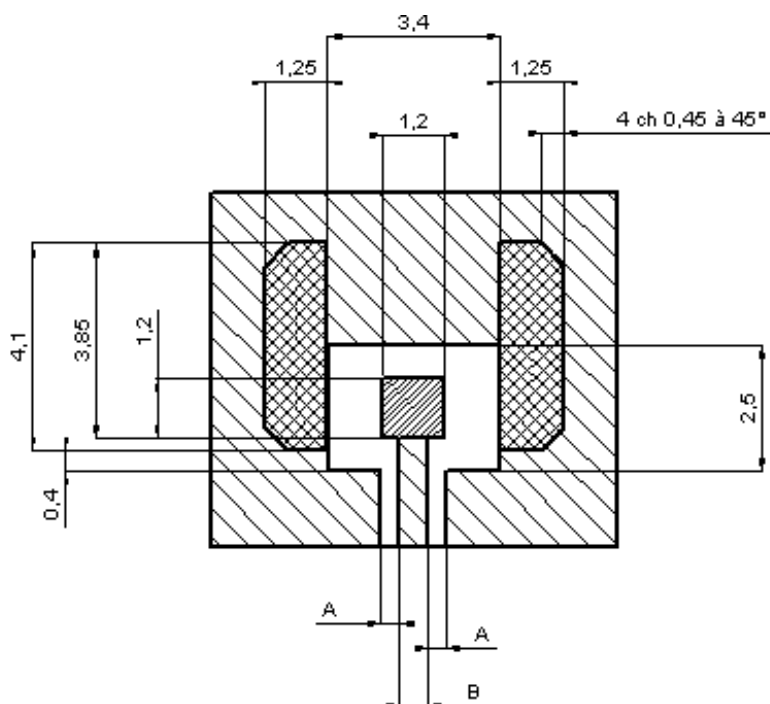
Ground and signal are on the same side  
 The material of PCB is glass is glass-epoxy Composite.



-  Gold over nickel for solder paste
-  Gold over nickel contact area free of any surface contaminant
-  Ground + varnish

APPLICATION 75Ω  
**WITH B = 0,55mm**

PCB thickness (mm)	Coplanar ligne A (mm)
0,8	0,57
1,0	0,45
1,2	0,41
1,6	0,37

APPILCATION 50Ω  
**WITH B = 1,2mm**

PCB thickness (mm)	Coplanar ligne A (mm)
0,8	0,183
1,0	0,190
1,2	0,195
1,6	0,20

Issue : 1213 C

In the effort to improve our products, we reserve the right to make changes judged to be necessary.



RIGHT ANGLE H3 RECEPTACLE SMT TYPE

**R107.303.040**

BOBINE 100

Series : UMP

# UMP SERIES INFORMATION

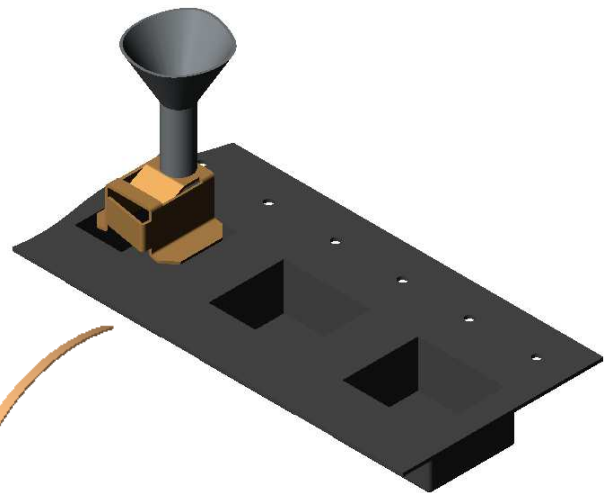
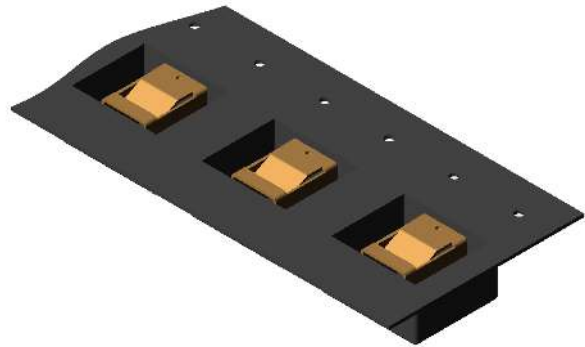

ASPIRATION PORT

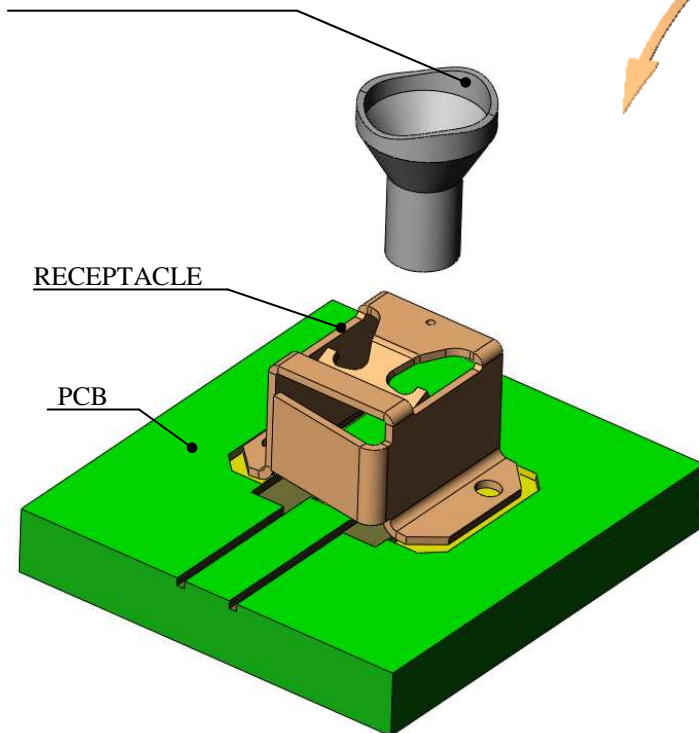

ASPIRATION PORT

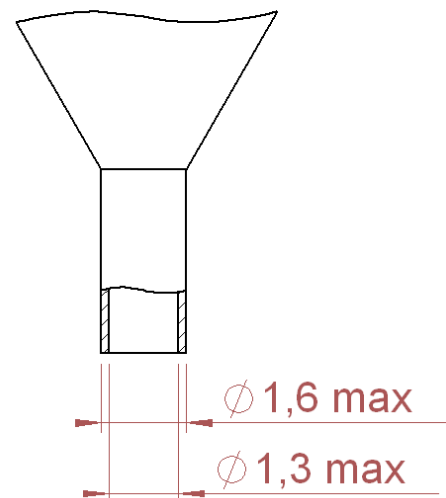

Issue : 1213 C

In the effort to improve our products, we reserve the right to make changes judged to be necessary.



**RIGHT ANGLE H3 RECEPTACLE SMT TYPE**

**R107.303.040**

**BOBINE 100**

Series : UMP

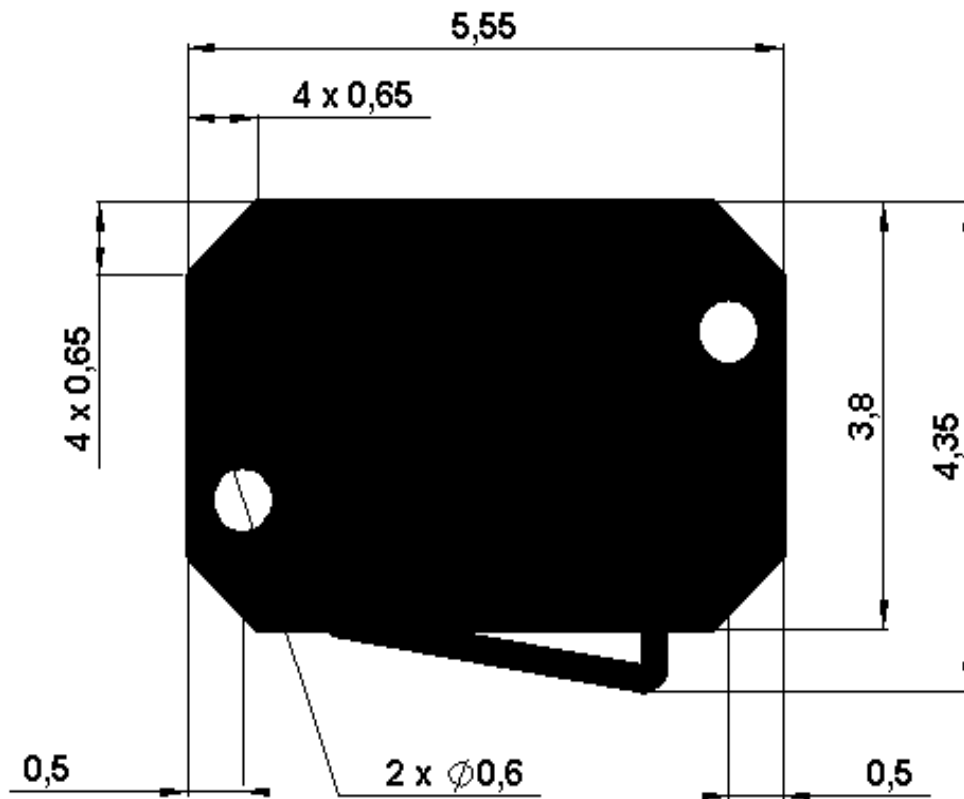

SHADOW FOR VIDEO CAMERA

**ASPIRATION AREA**

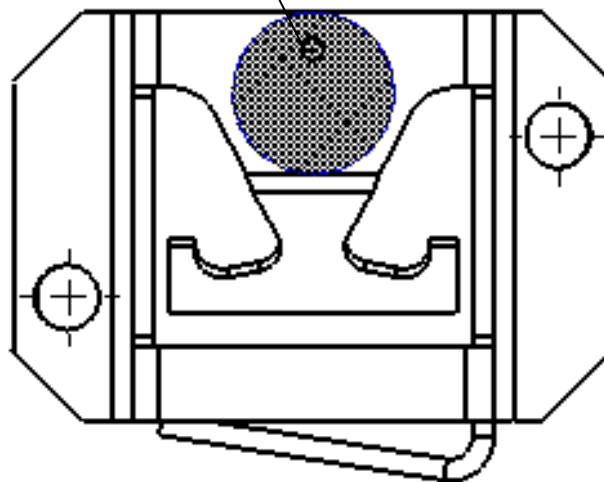

Issue : 1213 C

In the effort to improve our products, we reserve the right to make changes judged to be necessary.



RIGHT ANGLE H3 RECEPTACLE SMT TYPE

**R107.303.040**

BOBINE 100

Series : UMP

# UMP CONNECTING NOTE

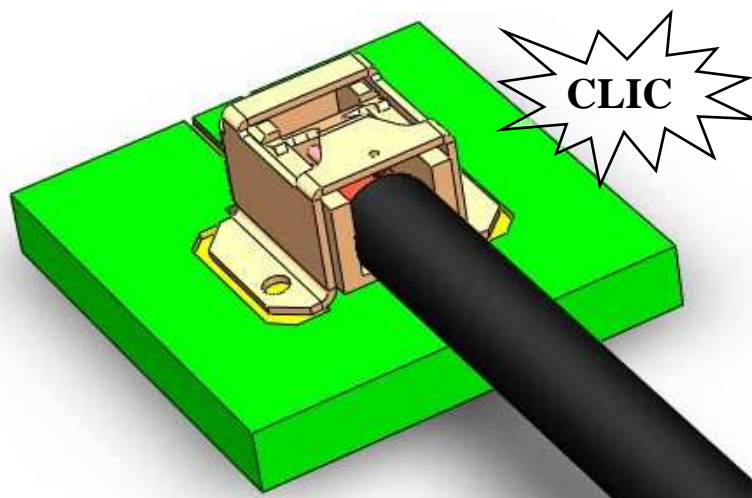
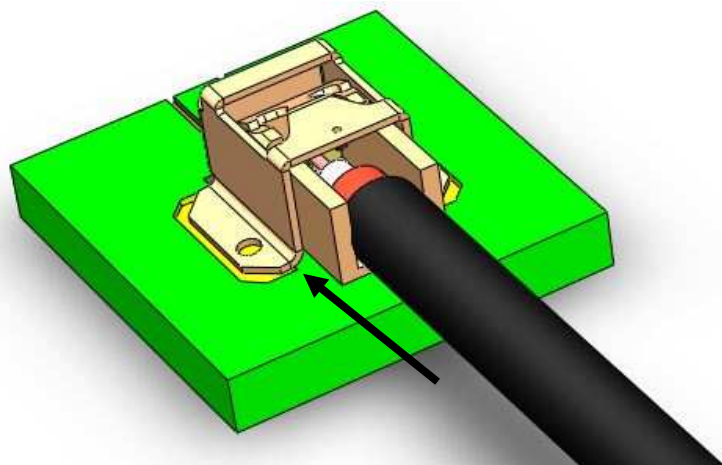
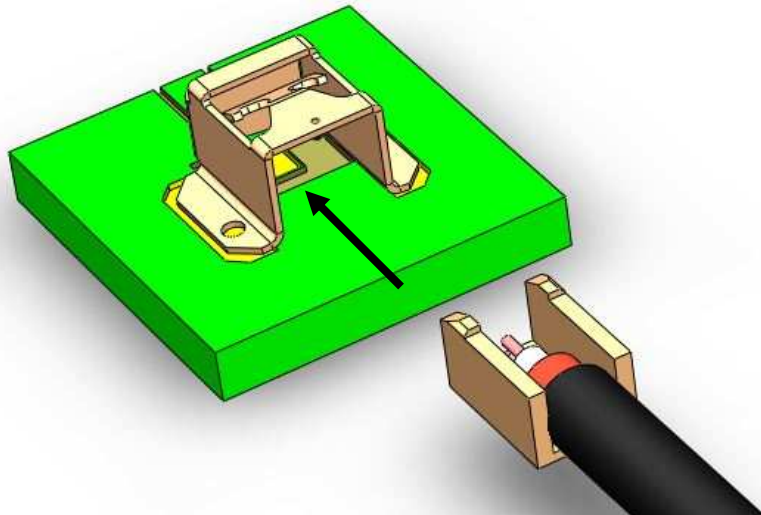

Issue : 1213 C

In the effort to improve our products, we reserve the right to make changes judged to be necessary.



**RADIALL**®

RIGHT ANGLE H3 RECEPTACLE SMT TYPE

**R107.303.040**

BOBINE 100

Series : UMP

# UMP CONNECTING NOTE

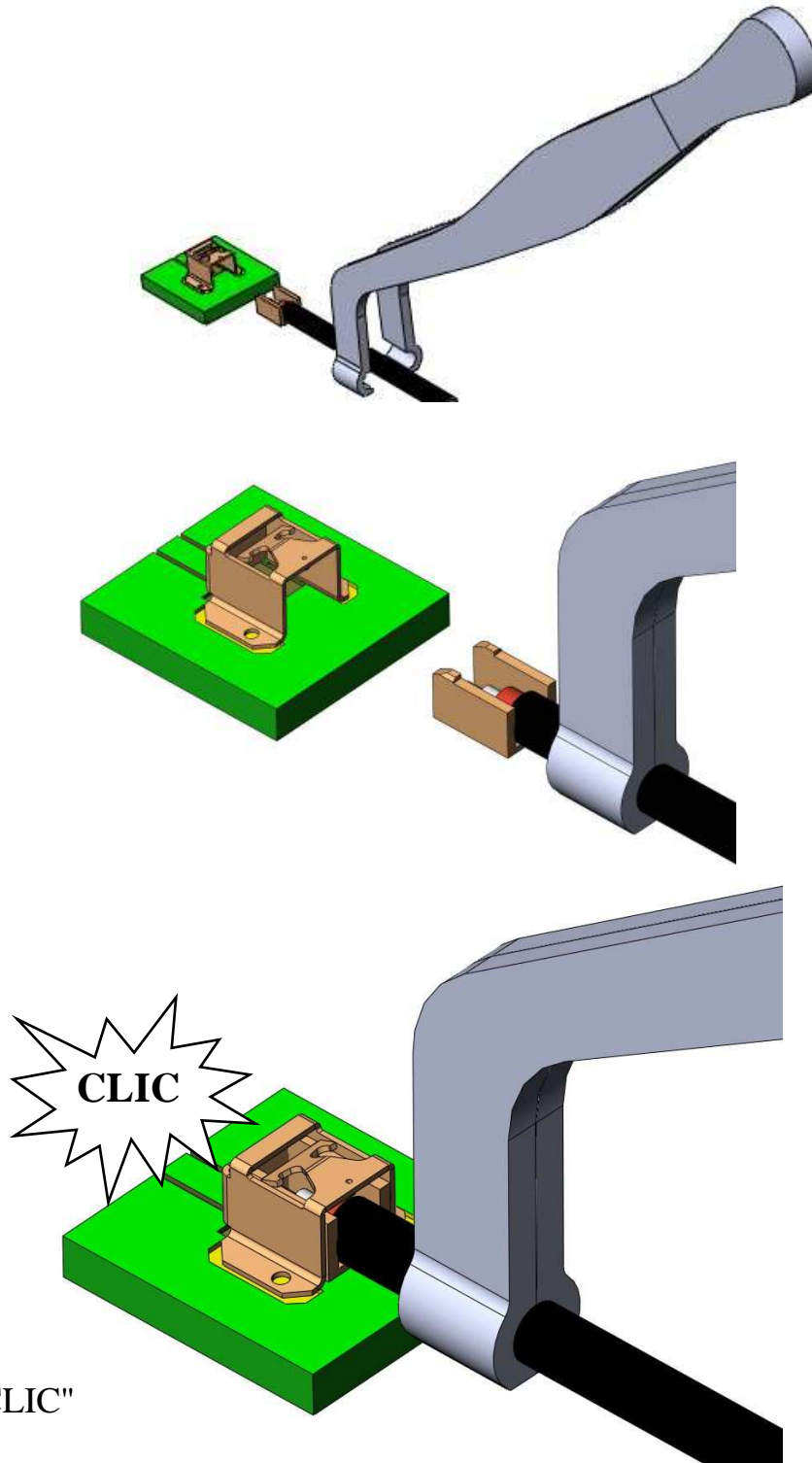

Issue : 1213 C

In the effort to improve our products, we reserve the right to make changes judged to be necessary.



RIGHT ANGLE H3 RECEPTACLE SMT TYPE

**R107.303.040**

BOBINE 100

Series : UMP

# UMP DISCONNECTING NOTE

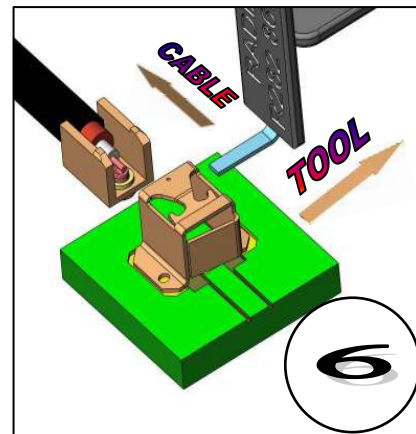
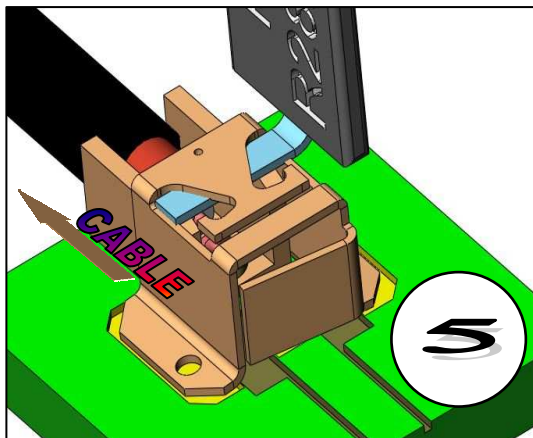
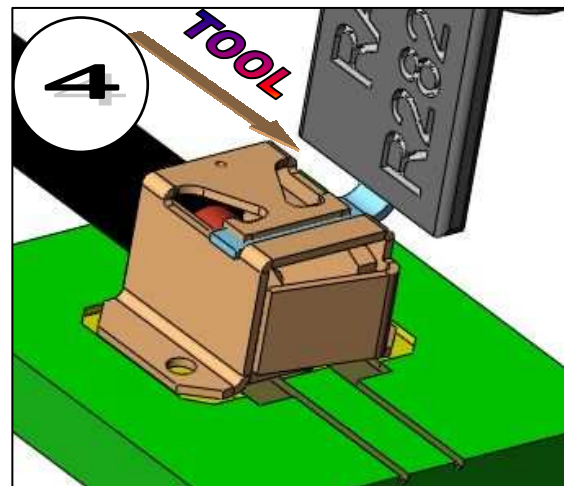
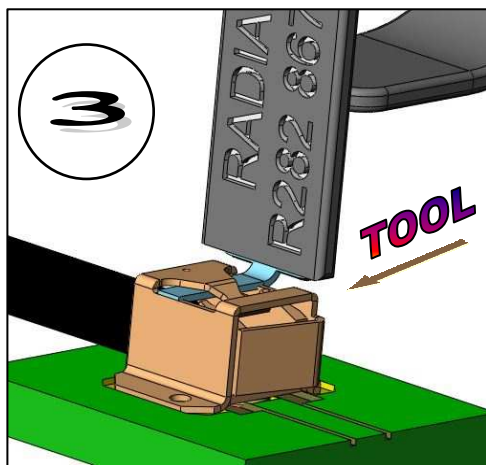
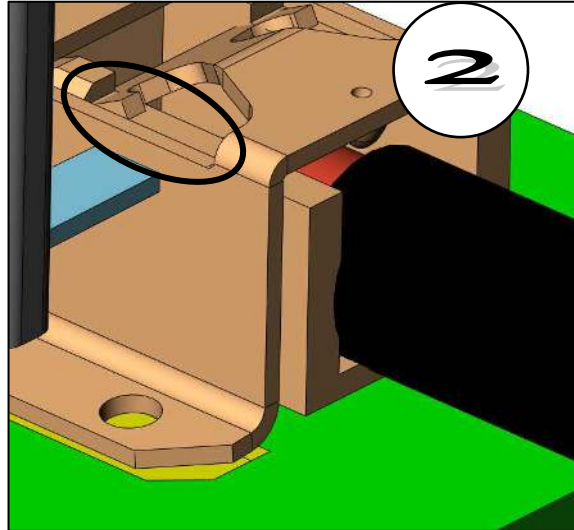
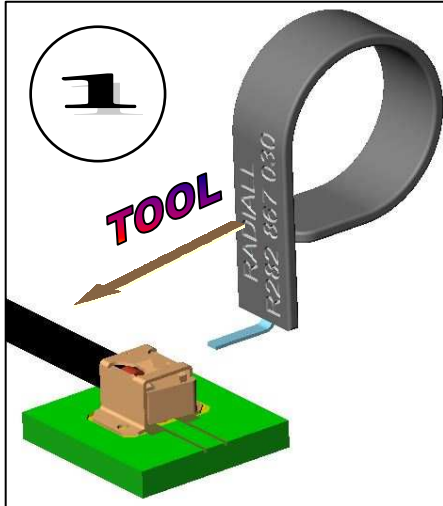

Issue : 1213 C

In the effort to improve our products, we reserve the right to make changes judged to be necessary.