

1. THIS RECEPTACLE WILL MATE WITH ANY SIZE 3,44 POSN. PLUG IN AMPLIMITE SERIES.
 2. CONNECTOR SUPPLIED WITHOUT CONTACTS; SHOWN FOR ILLUSTRATION ONLY.
 3. BE-CU RETENTION CLIPS ARE INCLUDED IN INSERTS AND INSTALLED WITH TINES POINTING TOWARDS MATING FACE.
 4. OVERALL DIMENSIONS DO NOT INCLUDE RAISED CAVITY IDENTIFICATION
 5. MARKING FAR SIDE REFERS TO WIDE SIDE OF KEYSTONE. NEAR SIDE REFERS TO NARROW SIDE OF KEYSTONE
- △ 100% INSPECTION REQUIRED PER BOEING 1B01:
 A. VISUAL
 B. DWV
 C. IR
7. CUSTOMER REQUIRES SINGLE LOT DATE CODE.

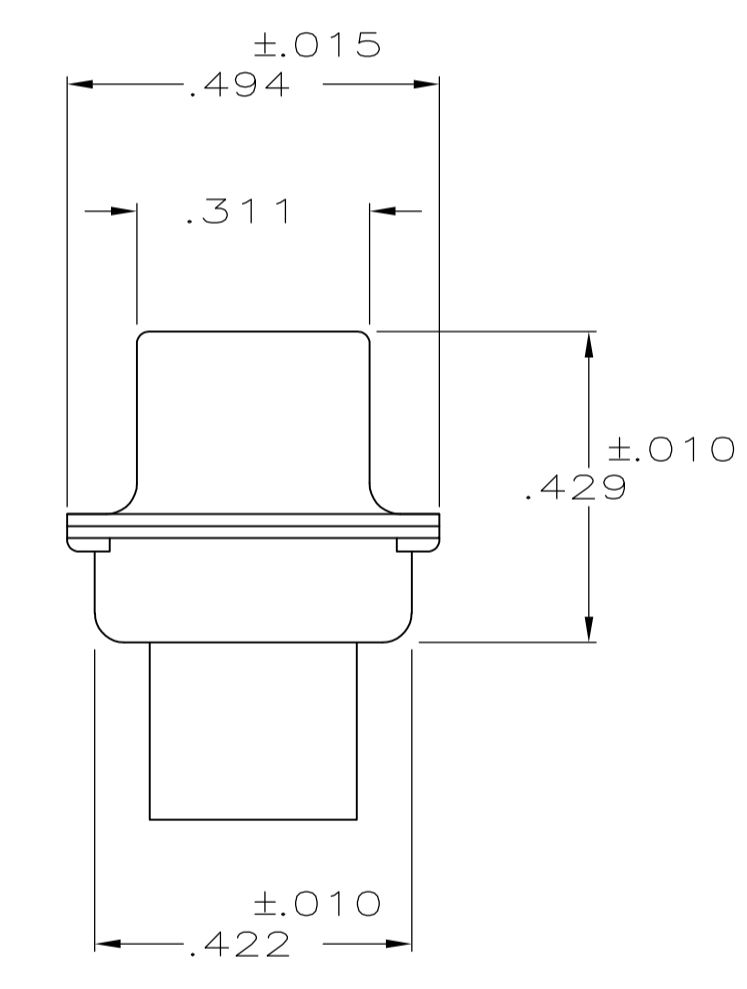
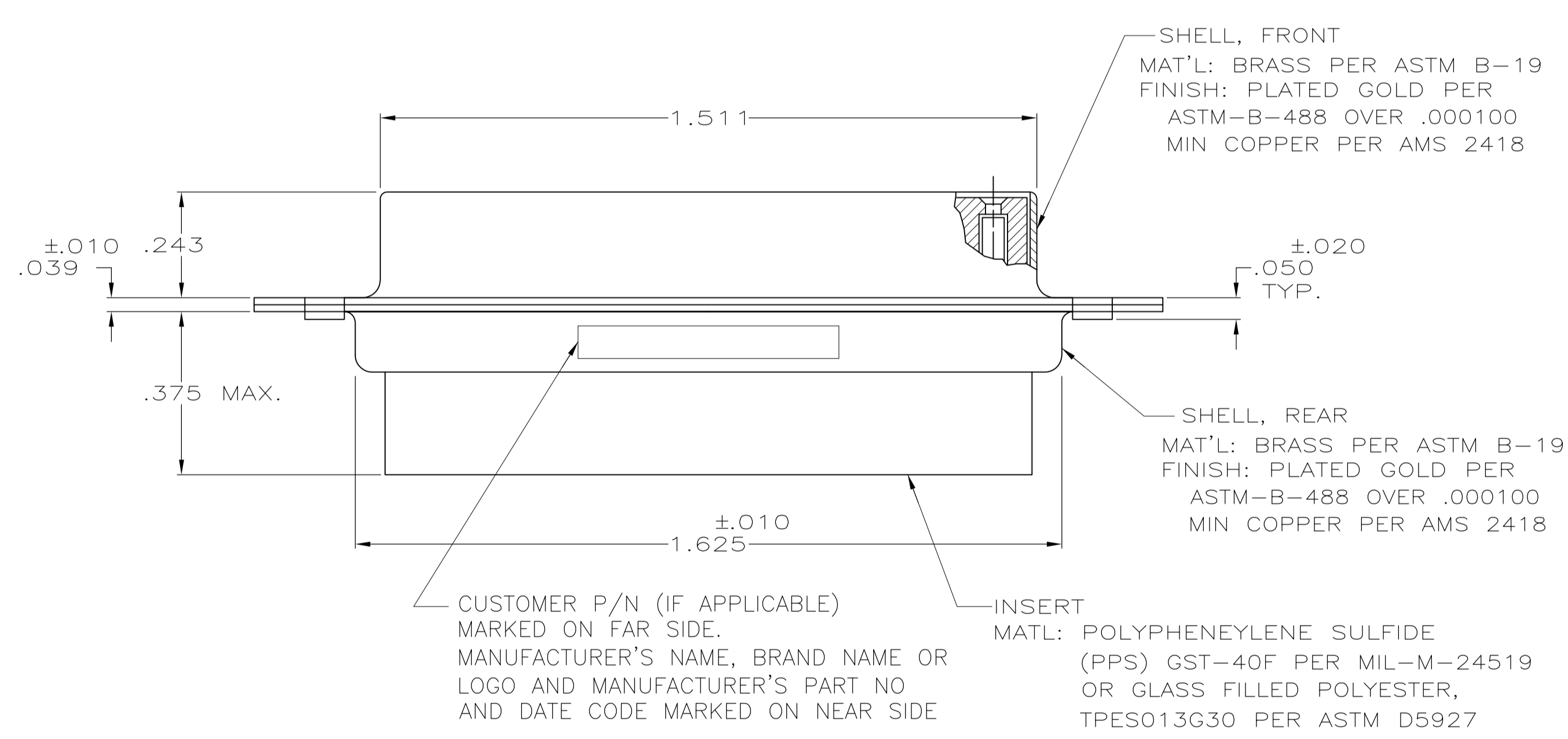
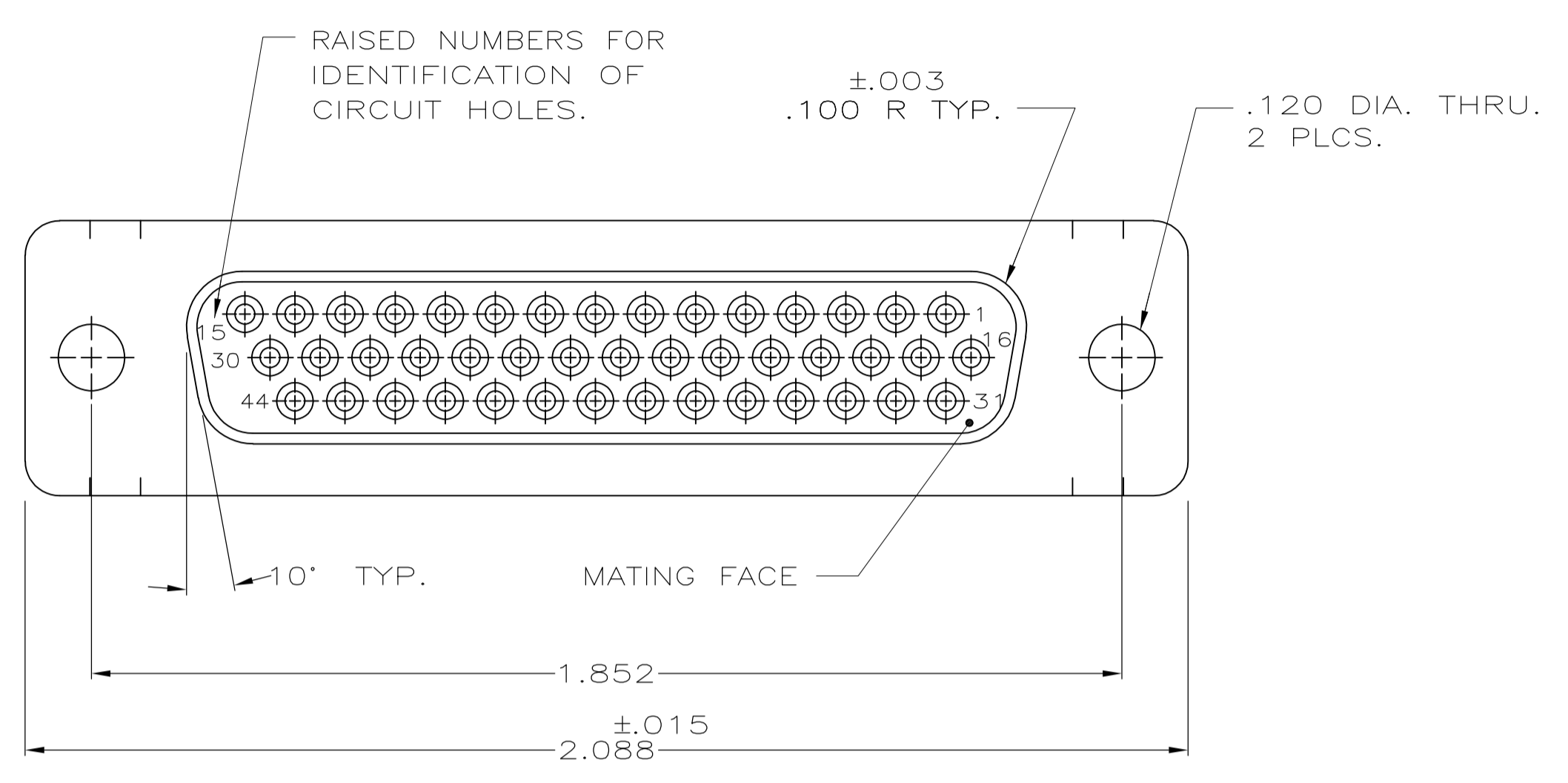

△ 6	1B01 - 003RHW	AS SHOWN △ 3	211645-2
△ 6	1B01 - 003	AS SHOWN △ 3	211645-1
REMARKS	CUSTOMER MARKING	DESCRIPTION	PART NO.

THIS DRAWING IS A CONTROLLED DOCUMENT.		DWN: D. ERDMAN 3-8-84	Tyco Electronics Corporation Harrisburg, PA 17105-3608
		CHK: B. YOHN 4-26-84	
		APVD: G. SACUNAS 7-5-84	NAME: G. SACUNAS
DIMENSIONS: INCHES	TOLERANCES UNLESS OTHERWISE SPECIFIED:	PRODUCT SPEC	APPLICATION SPEC
0 PLC ± -	1 PLC ± -	2 PLC ± -	3 PLC ± .005
4 PLC ± -	ANGLES ± -	RESTRICTED TO	
MATERIAL: SEE CALLOUT	FINISH: SEE CALLOUT	WEIGHT: -	SIZE: A1
CUSTOMER DRAWING		SCALE: NTS	SHEET: 1 OF 1