

PART
NAME

PLASTIBOX (STYLE B)

PART
No.

PS-11290

MATERIAL: HIGH-IMPACT ABS
COLOR: BLACK OR GRAY
FINISH: TEXTURED BODY WITH
SMOOTH TOP INSERT

TWO (2) #4 x 0.250" LG. SCREWS AND
TWO (2) #4 x 0.375" LG. SCREWS
SUPPLIED FOR ASSEMBLING TOP.

FOUR (4) NON-SKID STICK-ON FEET SUPPLIED.

*-USABLE AREA ON COVER ALSO
AVAILABLE FOR CUSTOM MOLDING.

NOTE: ALL DIMENSIONS HAVE ±0.015 TOLERANCE
UNLESS OTHERWISE SPECIFIED.

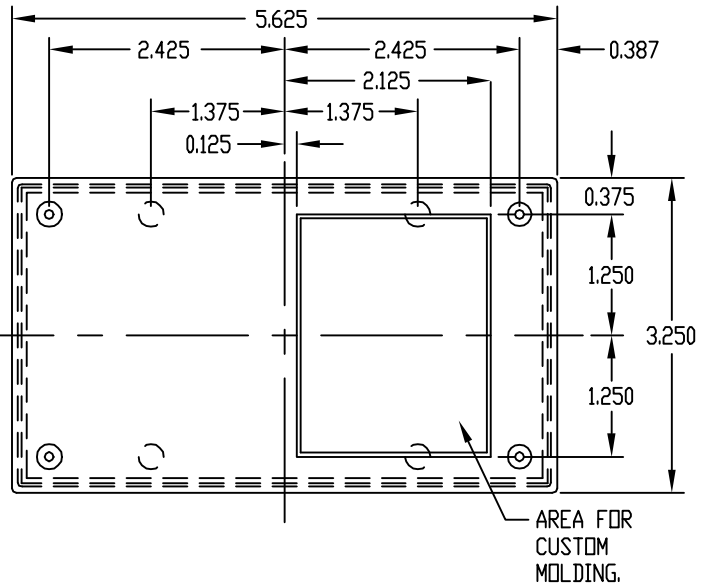
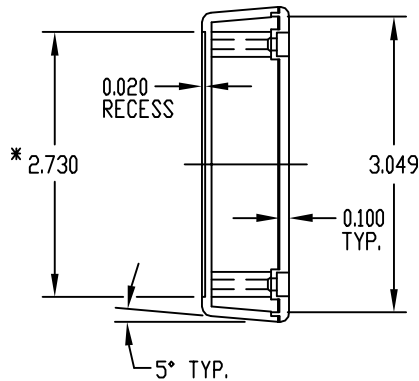
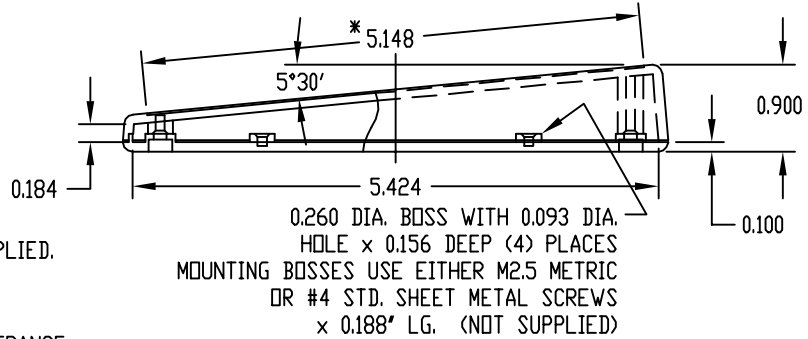

PART
NAME

PLASTIBOX (STYLE B)

PART
No.

PS-11292

MATERIAL: HIGH-IMPACT ABS
COLOR: BLACK OR GRAY
FINISH: TEXTURED BODY WITH
SMOOTH TOP INSERT

TWO (2) #4 x 0.250" LG. SCREWS AND
TWO (2) #4 x 0.375" LG. SCREWS
SUPPLIED FOR ASSEMBLING TOP.

FOUR (4) NON-SKID PUSH-ON FEET SUPPLIED

*-USABLE AREA ON COVER ALSO
AVAILABLE FOR CUSTOM MOLDING.

NOTE: ALL DIMENSIONS HAVE ±0.015 TOLERANCE
UNLESS OTHERWISE SPECIFIED.

