

SECTION Z-Z

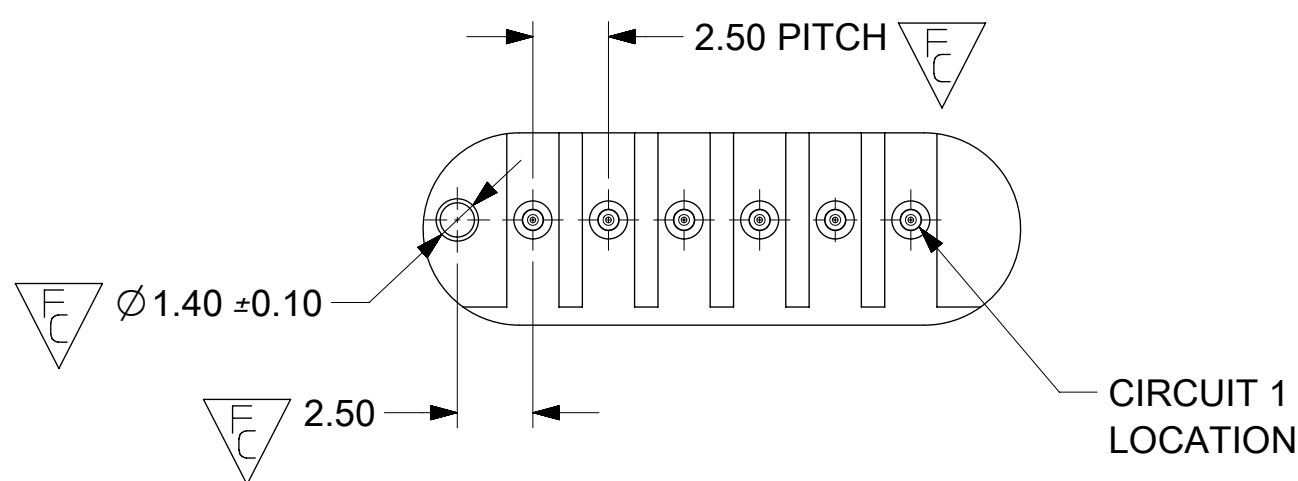

NOTES:

- HOUSING MATERIAL: LCP, 94 V-0, BLACK
PIN MATERIAL: 0.7mm ROUND BRASS
PIN PLATING: 2.5µm (100µin) TIN OVER
1.25µm (50µin) NICKEL.
- PART MATES WITH MOLEX RECEPTACLE SERIES 46528.
- PACKAGING SPECIFICATION: 500PCS. IN 96707-0012 SHIPPING CARTON, PADDED WITH PINK FOAM ON TOP AND BOTTOM.
- WHEN THIS PRODUCT IS USED IN A BLIND MATING APPLICATION THE SYSTEM LEVEL DESIGN MUST INCORPORATE GUIDANCE SO THE CONNECTORS ARE WITHIN THE CAPTURE ENVELOPE OF THE FLANGES ON THE HEADER OR PLUG HOUSING AND CAN THUS ALIGN THEMSELVES AS THEY COME TOGETHER. FLOAT IS ALSO REQUIRED IN THE OVERALL DESIGN, TO ALLOW THE PCB RECEPTACLE OR IT'S MATE TO MOVE INTO A STRESS-FREE POSITION AFTER MATING.
- PRODCUT SPECIFICATION: PS-45579-001

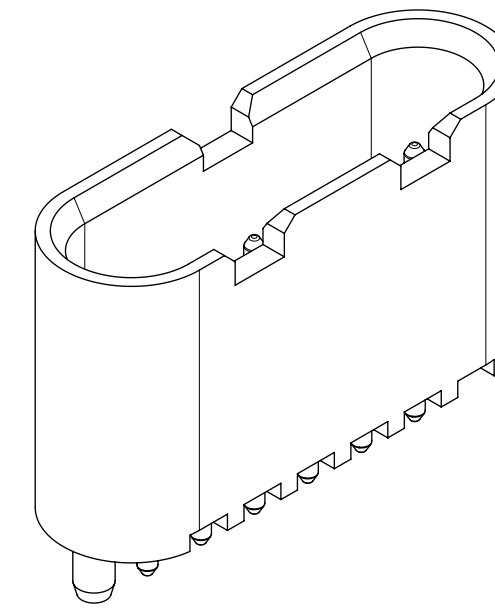
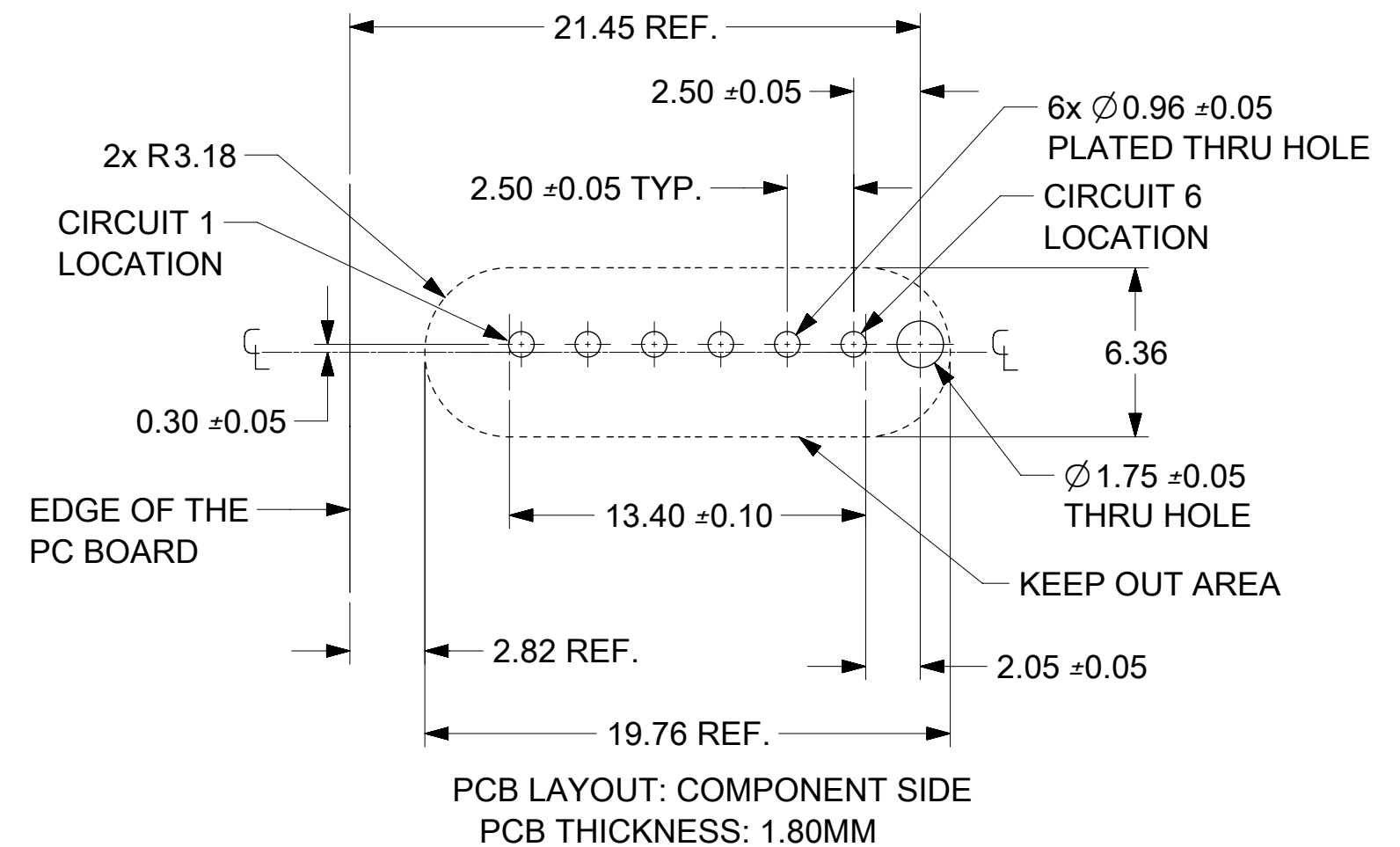

PCB LAYOUT: COMPONENT SIDE
PCB THICKNESS: 1.80MM

THIS DRAWING CONTAINS INFORMATION THAT IS PROPRIETARY TO MOLEX ELECTRONIC TECHNOLOGIES, LLC AND SHOULD NOT BE USED WITHOUT WRITTEN PERMISSION									
DIMENSION UNITS		SCALE		CURRENT REV DESC:					
MM		4:1							
GENERAL TOLERANCES (UNLESS SPECIFIED)									
		MM	INCH						
4 PLACES	±			EC NO: 625546					
3 PLACES	±			DRWN: RLALSANGI 2017/06/27					
2 PLACES	±	0.13		CHK'D: ISHWARG 2019/10/18					
1 PLACE	±	0.25		APPR: ISHWARG 2019/10/18					
0 PLACES	±			INITIAL REVISION:					
		ANGULAR TOL ± 0.5°		DRWN: DROSCA 2007/04/10					
				APPR: JCOMERCI 2007/04/10					
DRAFT WHERE APPLICABLE MUST REMAIN WITHIN DIMENSIONS				THIRD ANGLE PROJECTION		DRAWING		SERIES	
				C-SIZE		46511			
DOCUMENT STATUS				P1		RELEASE DATE		2019/10/18 08:25:56	

molex

SPOX BMI HEADER ASSEMBLY
VERTICAL, SINGLE ROW 1X6 2.5MM SPACING

PRODUCT CUSTOMER DRAWING

DOCUMENT NUMBER	DOC TYPE	DOC PART	REVISION
SD-46511-100	PSD	001	B

MATERIAL NUMBER	CUSTOMER	SHEET NUMBER
465111000	IBM	1 OF 1