

DESIGNED FOR USE WITH 0.250 SEMI-RIGID CABLE	
CABLE ENTRY DIAMETER MINIMUM	
COLLAR	.252
CLAMP NUT	.260
CONTACT	.061

REVISIONS			
REV	DESCRIPTION	DATE	APPROVED
04 ₁	REVISED	PATLAN 12-9-98	<i>[Signature]</i> 4/19/99
B	PER EC 0U20-0116-01-03	16NOV01	<i>[Signature]</i> 16NOV01

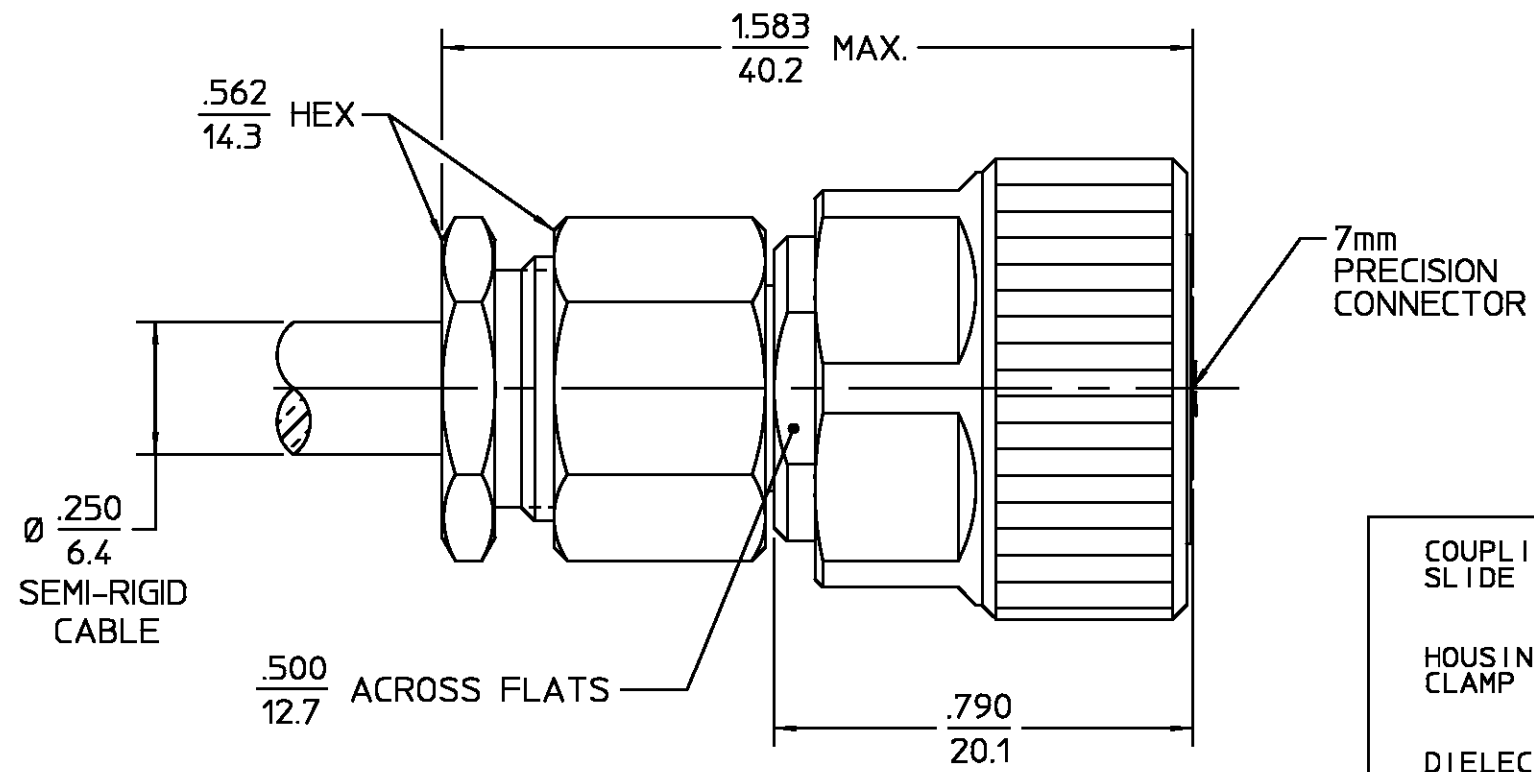

COUPLING NUT SLIDE ASSY	STAINLESS STEEL PER ASTM-A484 AND ASTM- A582, TYPE 303	ELECTRO-POLISHED
HOUSING CLAMP NUT	STAINLESS STEEL PER ASTM-A484 AND ASTM- A582, TYPE 303	PASSIVATE PER QQ-P-35
DIELECTRIC	PTFE FLUOROCARBON PER ASTM-D-1457	N/A
CONTACT EXT.	BERYLLIUM COPPER PER ASTM B 196 OR ASTM-B-197 ALLOY C17300, CONDITION H	GOLD PLATE PER MIL-G-45204
COLLAR & CENTER CONTACT	BRASS PER ASTM-B-16. HALF HARD	GOLD PLATE PER MIL-G-45204

COMPONENT	MATERIAL	FINISH
-----------	----------	--------

UNLESS OTHERWISE SPECIFIED DIMENSIONS ARE IN INCHES	DRAWN BY SK	DATE 3-27-78	AMP AMP Incorporated 140 Fourth Avenue Waltham, MA 02451-7599
	CHECKED BY KW	5-19-78	
	APP'D BY RMF	5-25-98	

These drawings and specifications are the property of AMP Interconnect Div. and shall not be reproduced or copied or used in whole or in part as the basis for the manufacture or sale of item(s) without written permission.	USE ASSY PROCEDURE	TITLE 7mm STRAIGHT CABLE CONNECTOR-CLAMP ATTACHMENT	
	408-08316 (70-003)	NO. A.P.	
	SIZE B	CODE IDENT NO. 26805	7301-7650-00
SCALE 3:1		SHEET 1 OF 1	

.XXX = in
XX.X = mm (REF)

CUSTOMER DRAWING

AMP PART # 1061934-1
SHEET 1 OF 1 REV B