

QT-Brightek High Power Series

3W High Power UV LED

Part No.: QBHP684E-UVXXXYS Series

Y: Viewing Angle
XXX: UV Wavelength
S: 500mA

Table of Contents:

Introduction	3
Electrical / Optical Characteristic (Ta=25 °C)	4
Absolute Maximum Rating	4
Characteristic Curves.....	6
IR Reflow Soldering Profile	7
Packing	8
Labeling	9
Caution	9
Ordering Information.....	10
Revision History	11
Disclaimer	11

Introduction

Feature:

- 3W High Power UV LED
- Clear Lens
- Packed in tape and reel
- ESD rating: 8KV (HBM)
- Viewing Angle: A=60°, B=120°

Description:

This 3W high power UV LED has compact size of 3.5 x 3.5mm. It is ideal for various UV applications.

Application:

- UV curing
- UV marking
- Purification
- Inspection
- Sterilization and Disinfection

Certification & Compliance:

- TS16949
- ISO9001
- RoHS Compliant



Outline Dimensions:

60°

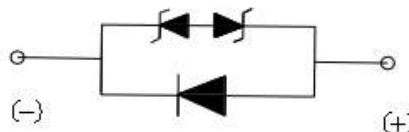
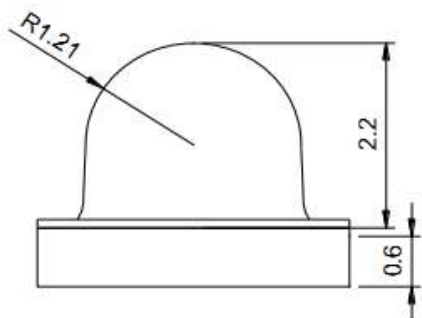
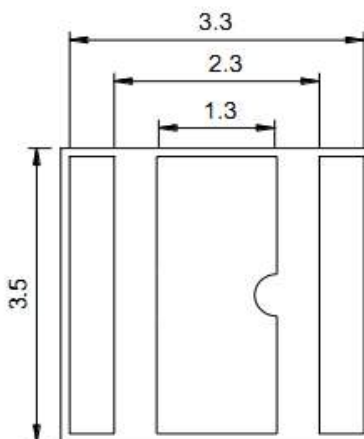
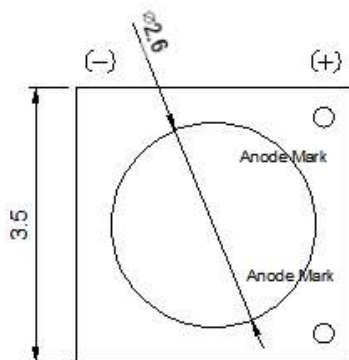

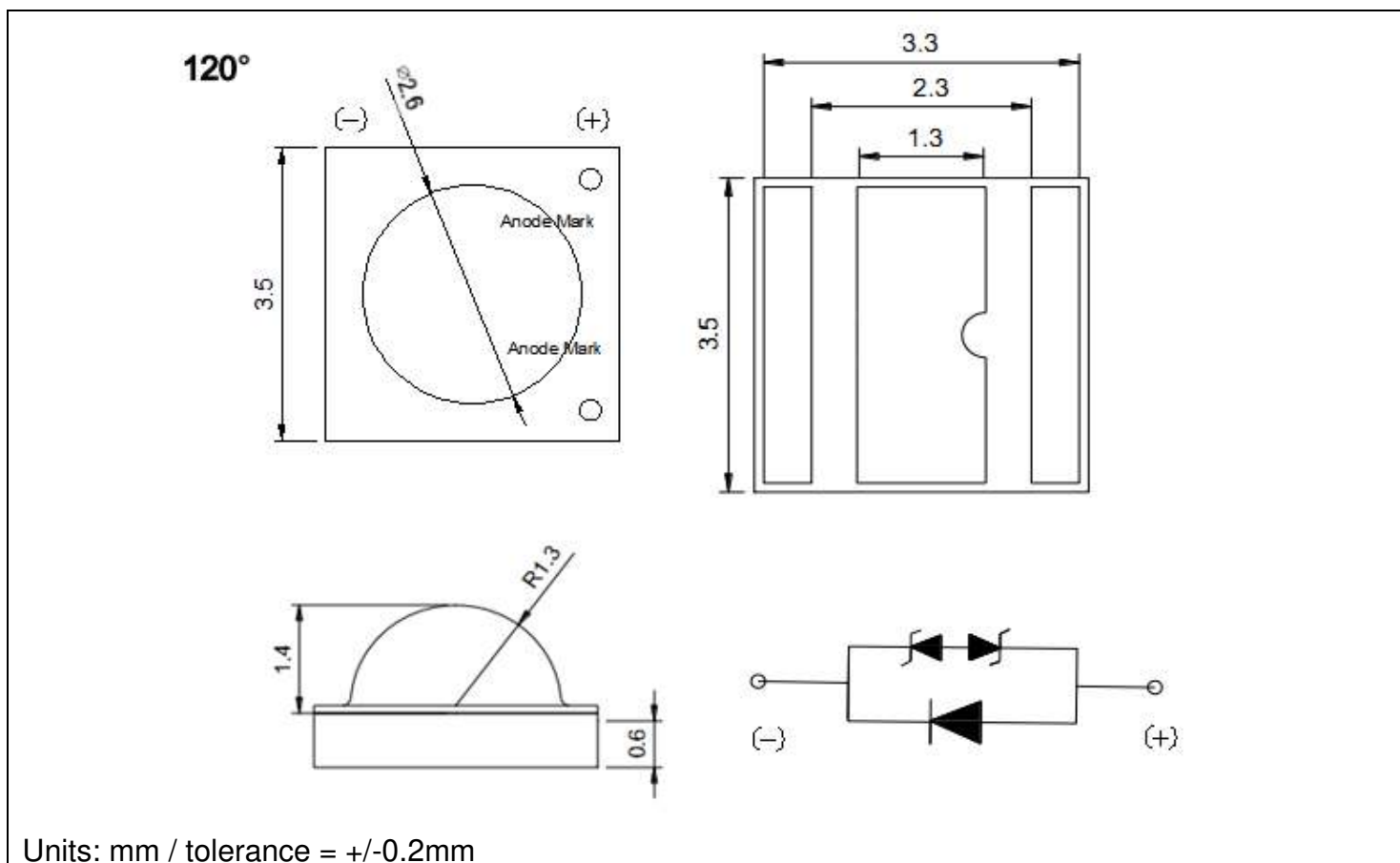

Electrical / Optical Characteristic (Ta=25 °C)

Part Number	Color	I _F (mA)	V _F (V)			λ _p (nm)			P _o (mW)		
			Min.	Typ.	Max.	Min.	Typ.	Max.	Min.	Typ.	Max.
QBHP684E-UV365AS	UV	500	3.0	3.4	3.8	365	367	370	420	550	700
QBHP684E-UV365BS											
QBHP684E-UV385AS											
QBHP684E-UV385BS											
QBHP684E-UV395AS											
QBHP684E-UV395BS											
QBHP684E-UV405AS											
QBHP684E-UV405BS											

Absolute Maximum Rating

Material	P _d (W)	I _F (mA)	I _{FP} (mA)*	V _R (V)	T _{OP} (°C)	T _{ST} (°C)	T _{SOL} (°C)
InGaN	2.8	700	1000	5	-40 to +80	-40 to +100	260

*Duty 1/10 @ 10ms Pulse Width

Forward Voltage V_F @ $I_F=500\text{mA}$

Bin	Min.	Max.	Unit
A	3.0	3.2	V
B	3.2	3.4	
C	3.4	3.6	
D	3.6	3.8	

Radiometric Power P_O for UV365S @ $I_F=500\text{mA}$

Bin	Min.	Max.	Unit
A4	420	460	mW
A5	460	500	
A6	500	540	
A7	540	580	
A8	580	620	
A9	620	660	
B1	660	700	

Radiometric Power P_O for UV385S, UV395S & UV405S @ $I_F=500\text{mA}$

Bin	Min.	Max.	Unit
B2	700	740	mW
B3	740	780	
B4	780	820	
B5	820	860	
B6	860	900	
B7	900	1000	

Tolerance of measurement of forward voltage: $\pm 0.1\text{V}$ Tolerance of measurement of Radiometric Power: $\pm 50\text{mW}$ Tolerance of measurement of dominant wavelength: $\pm 2\text{nm}$

Characteristic Curves

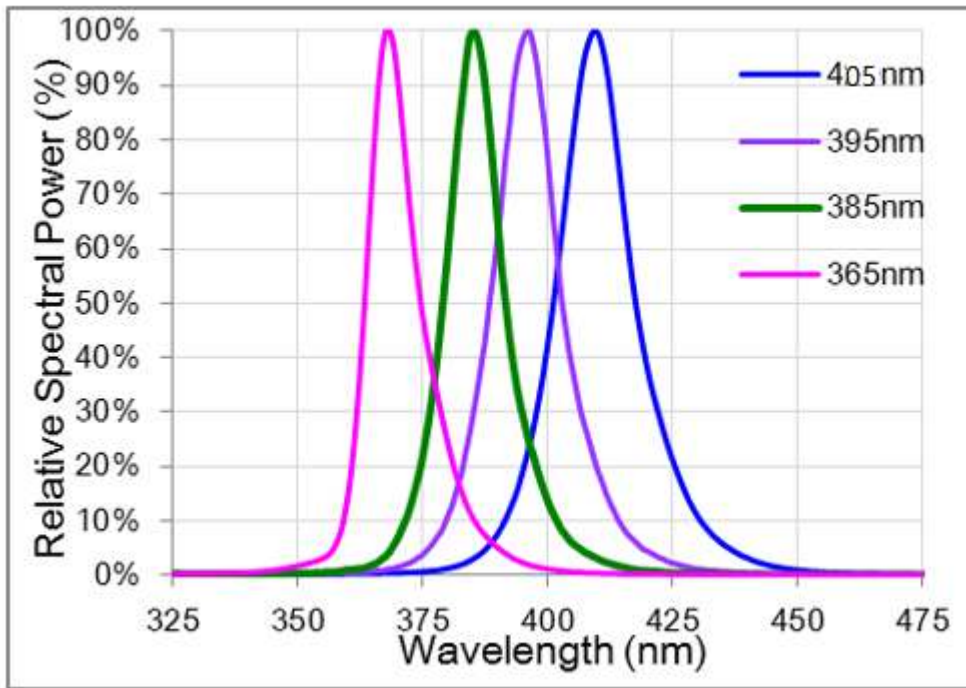
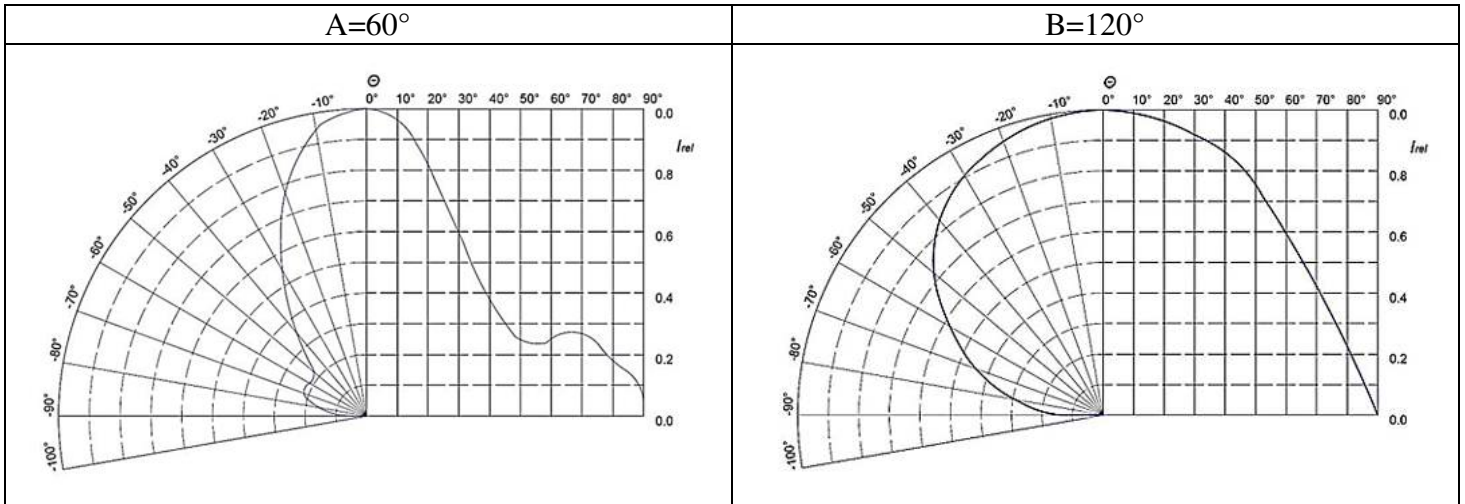

IR Reflow Soldering Profile

Lead Free solder

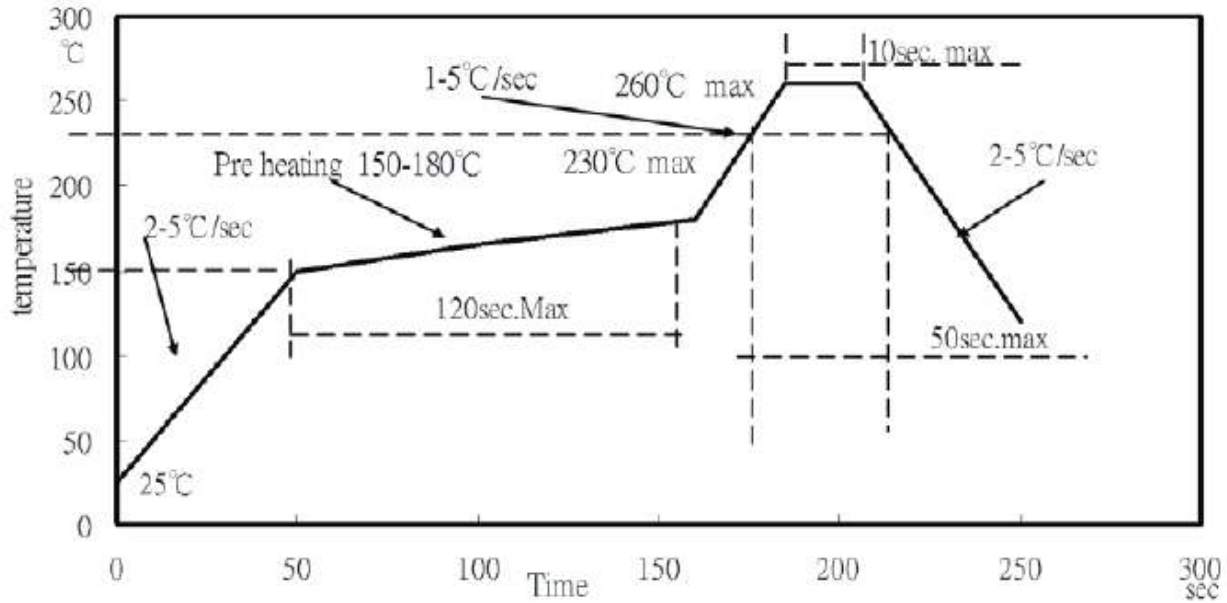

Recommended Soldering Pad:

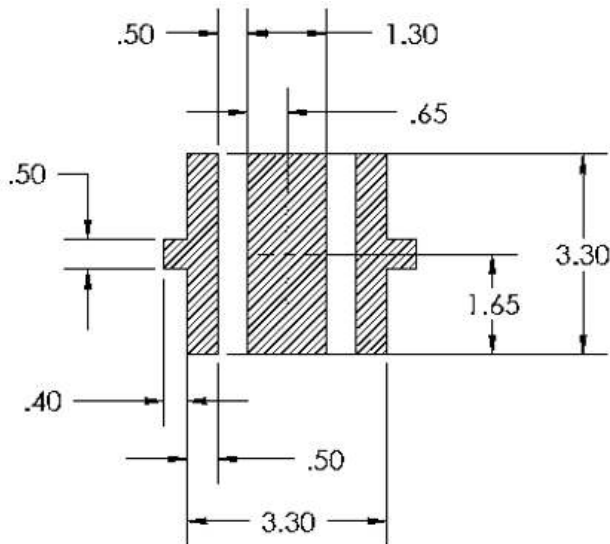

RECOMMENDED PCB SOLDER PAD

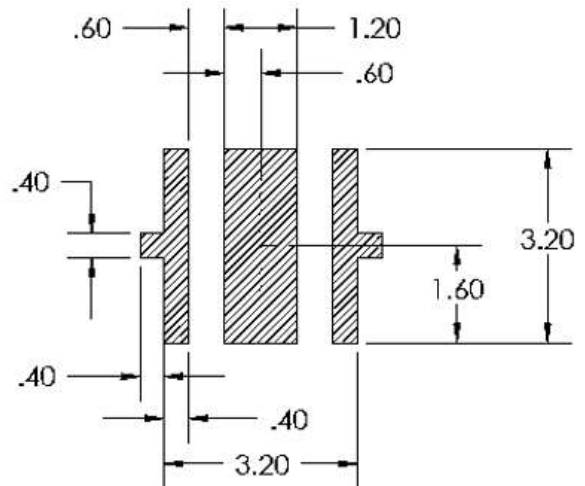

RECOMMENDED STENCIL PATTERN (HATCHED AREA IS OPENING)

§ Suggest stencil t = 0.12 mm

Unit: mm

Packing

Tape and Reel:

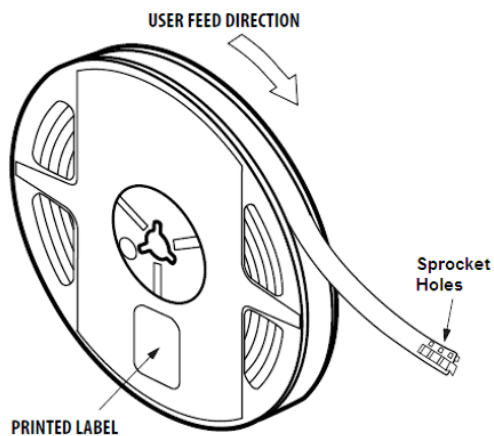
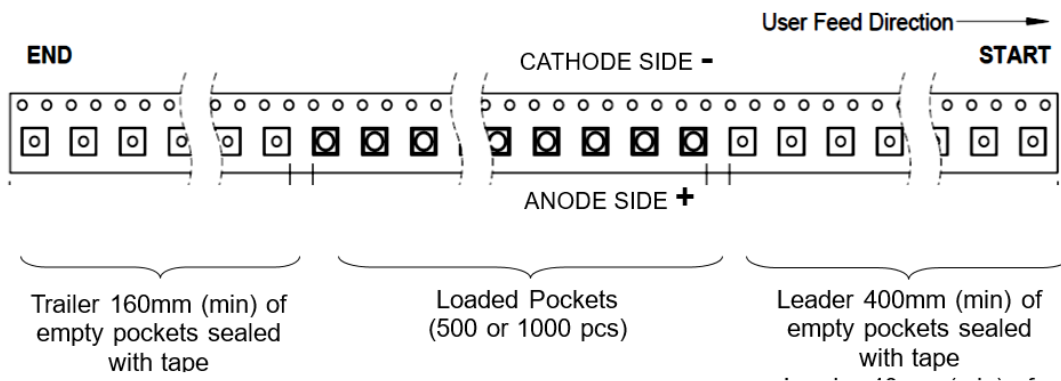
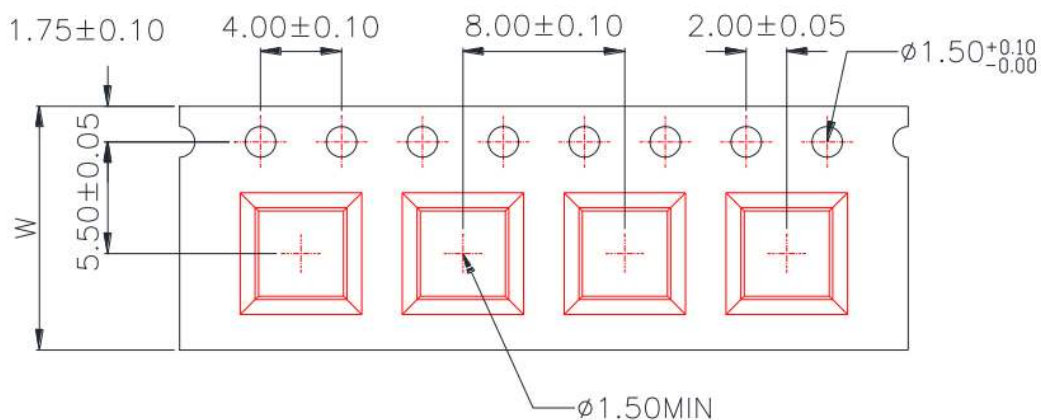

Labeling

Part No: _____

Customer P/N: _____

Item: _____

Q'ty: _____

Vf: _____

Iv: _____

WI: _____

Date: _____

Made in Taiwan**Caution**

	CAUTION
	<ul style="list-style-type: none"> • This UV LED during operation radiates intense UV light. • Do not look directly into the UV light during operation of the device. This can be harmful to the eyes even for brief period due to the intense UV light. • If viewing the UV light is necessary, please use UV filtered glasses to avoid damage by the UV light. • If the UV LED in your product might be viewed directly, please affix a caution label to your product to that effect. <p style="text-align: center;"> Avoid direct eye exposure to UV light Keep out of reach of children </p>

Ordering Information

Part #	Orderable Part #	Spec Range	Quantity per reel
QBHP684E-UV365AS	QBHP684E-UV365AS	Po=550mW typ. @ If=500mA, λp=365nm to 370nm	500 units
QBHP684E-UV365BS	QBHP684E-UV365BS		1000 units
QBHP684E-UV385AS	QBHP684E-UV385AS	Po=850mW typ. @ If=500mA, λp=380nm to 390nm	500 units
QBHP684E-UV385BS	QBHP684E-UV385BS		1000 units
QBHP684E-UV395AS	QBHP684E-UV395AS	Po=850mW typ. @ If=500mA, λp=390nm to 400nm	500 units
QBHP684E-UV395BS	QBHP684E-UV395BS		1000 units
QBHP684E-UV405AS	QBHP684E-UV405AS	Po=850mW typ. @ If=500mA, λp=400nm to 410nm	500 units
QBHP684E-UV405BS	QBHP684E-UV405BS		1000 units

Revision History

Description:	Revision #	Revision Date
New Release of QBHP684E-UVXXXYS_series	V1.0	02/01/2016
Update VF binning and dimension drawing	V1.1	08/16/2016
Update radiometric power binning	V1.2	02/03/2017

Disclaimer

QT-BRIGHTTEK reserves the right to make changes without further notice to any products herein to improve reliability, function or design. QT-BRIGHTTEK does not assume any liability arising out of the application or use of any product or circuit described herein; neither does it convey any license under its patent rights, nor the rights of others.

Life Support Policy

QT-BRIGHTTEK's products are not authorized for use as critical components in life support devices or systems without the express written approval of QT-BRIGHTTEK. As used herein:

1. Life support devices or systems are devices or systems which, (a) are intended for surgical implant into the body, or (b) support or sustain life, and (c) whose failure to perform when properly used in accordance with instructions for use provided in the labeling, can be reasonably expected to result in a significant injury of the user.
2. A critical component in any component of a life support device or system whose failure to perform can be reasonably expected to cause the failure of the life support device or system, or to affect its safety or effectiveness.