

- NOTES:
1. THE IDC TRAY SLIDES OUT FROM THE RACK TO ALLOW FOR IDC PUNCHING FROM THE FRONT OF THE PATCH PANEL.
 2. 48 MT JACKS - STEREO SPACED WITH THE NORMALS OUT TO IDC'S.
 3. TIP NORMAL, RING NORMAL, TIP, RING AND SLEEVE CONNECTIONS ARE MADE ON SWITCHCRAFT'S PROFESSIONAL PUNCHDOWN TERMINALS (PPT). NOT ALL PPT'S ARE SHOWN.
 4. USE SWITCHCRAFT PUNCH DOWN TOOL #PTI TO MAKE WIRE CONNECTIONS.
 5. ACCOMODATES #22, 24, or 26 AWG, STRANDED OR SOLID WIRE.

- BLUE PPT - TIP NORMAL
- ORANGE PPT - RING NORMAL
- RED PPT - TIP
- BLACK PPT - RING
- WHITE PPT - SLEEVE
- WHITE PPT - SLEEVE
- BLUE PPT - TIP NORMAL
- ORANGE PPT - RING NORMAL
- RED PPT - TIP
- BLACK PPT - RING

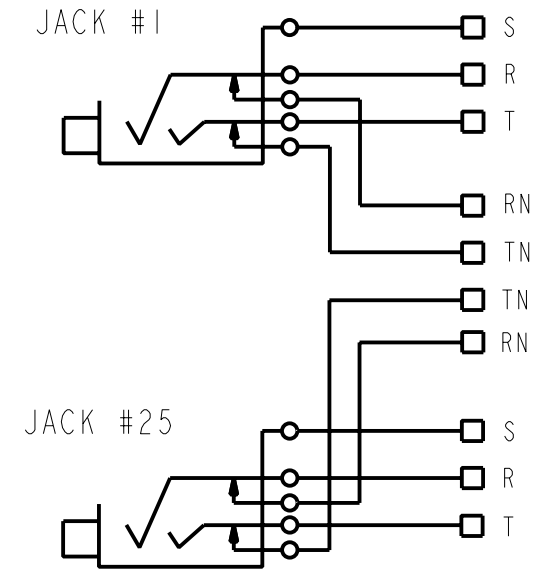

NORMALS OUT
TYP 24 PLACES

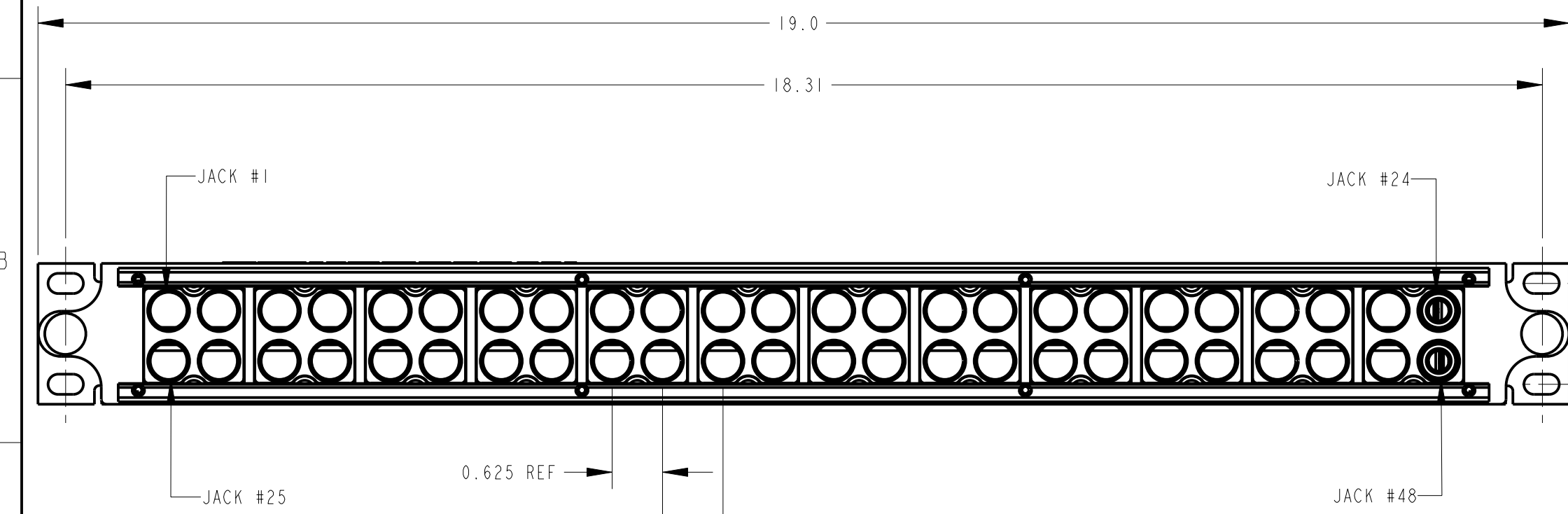

| | | | | | | | | | | |
|---|-----|---------|---------|-------|---|----------|--|----------------|--|-----|
| <p>★ STAR SYMBOL DENOTES CRITICAL DIMENSION</p> <p>UNLESS OTHERWISE SPECIFIED</p> <p>1. ALL DIMENSIONS IN INCHES - TWO PLACE DECIMALS ±0.01 - THREE PLACE DECIMALS ±0.005 - ANGLES ±1° - ALL DIA. CONCENTRIC WITHIN 0.005 T.I.R.</p> <p>2. FEATURES ON THE SAME CENTERLINE MUST BE ALIGNED WITHIN ±0.002</p> <p>3. REMOVE ALL BURRS</p> | | | | | <p>THIS DRAWING DESCRIBES A DESIGN CONSIDERED PROPRIETARY IN NATURE, DEVELOPED AND MANUFACTURED BY SWITCHCRAFT INC. AND IS RELEASED ON A CONFIDENTIAL BASIS FOR IDENTIFICATION PURPOSES ONLY.</p> | | | | | |
| SIZE | | WIDTH | | MULT | | LBS/M | | TEMPER | | |
| FINISH | | | | | | MATERIAL | | | | |
| SPEC No. | | | | | | SPEC No. | | | | |
| FIRST USED ON | | | | SCALE | | | | | | |
| | | | | 1:2 | | | | | | |
| DATE DRAWN | BY | CHKD | APVD | | | | | | | |
| 19-Jan-99 | TJK | 1-19-00 | 1-19-99 | | | | | | | |
| NAME | | | | | | | | PART No. | | REV |
| 48 MT JACK TO IDC FRONT ACCESS | | | | | | | | MTPFA48KINO_CD | | A |
| PATCH PANEL - NORMALS OUT | | | | | | | | | | |

CUSTOMER DRAWING