

REVISIONS					
REV	DATE	DESCRIPTION	BY	CHK	APP'D
J1	21JUL2022	REVISED PER ECR-21-118222	JP	VS	

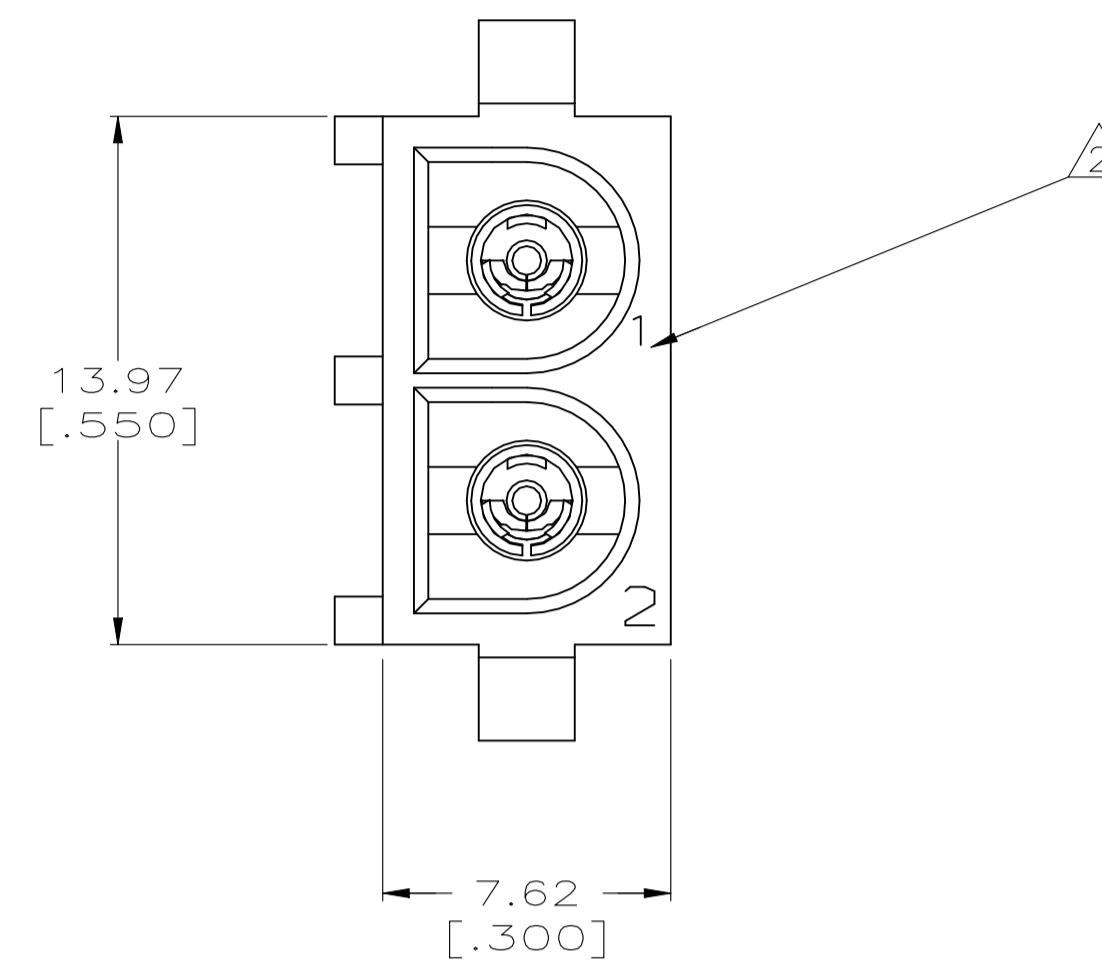

- PARTS COMPLY TO AMP SOLDERABILITY SPECIFICATION 109-11-3.
- CIRCUIT IDENTIFICATION CHARACTERS ARE ADJACENT TO THE INDICATED CAVITIES, BUT LOCATION AND ORIENTATION MAY DIFFER FROM PRINT.
- DIMENSIONS IN BRACKETS ARE IN INCHES.
- DIMENSIONS SHOWN REPRESENT PRODUCT IN DRY CONDITION. ADDITIONAL 2% GROWTH DUE TO END USE LOCATION MOISTURE ABSORPTION MAY OCCUR AND SHOULD BE ACCOUNTED FOR.

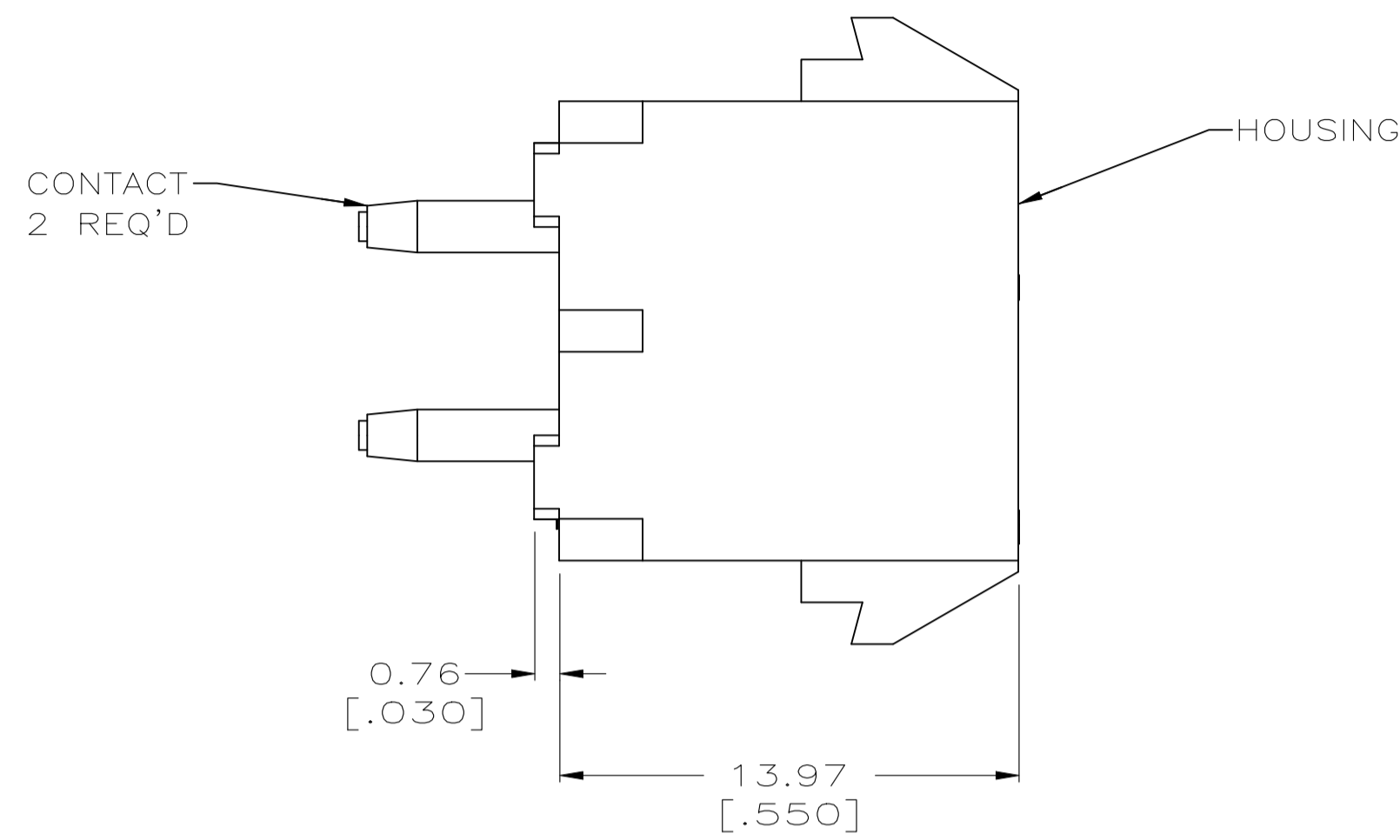
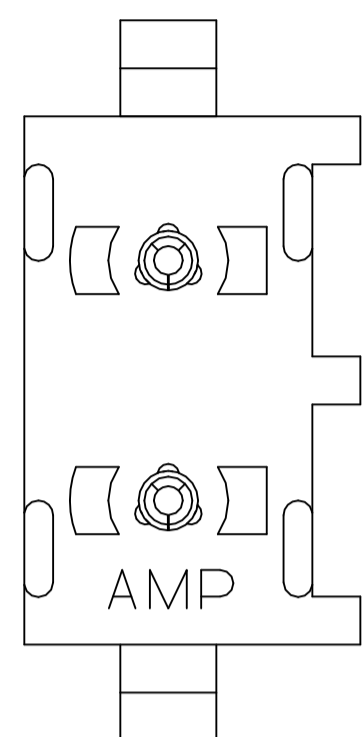
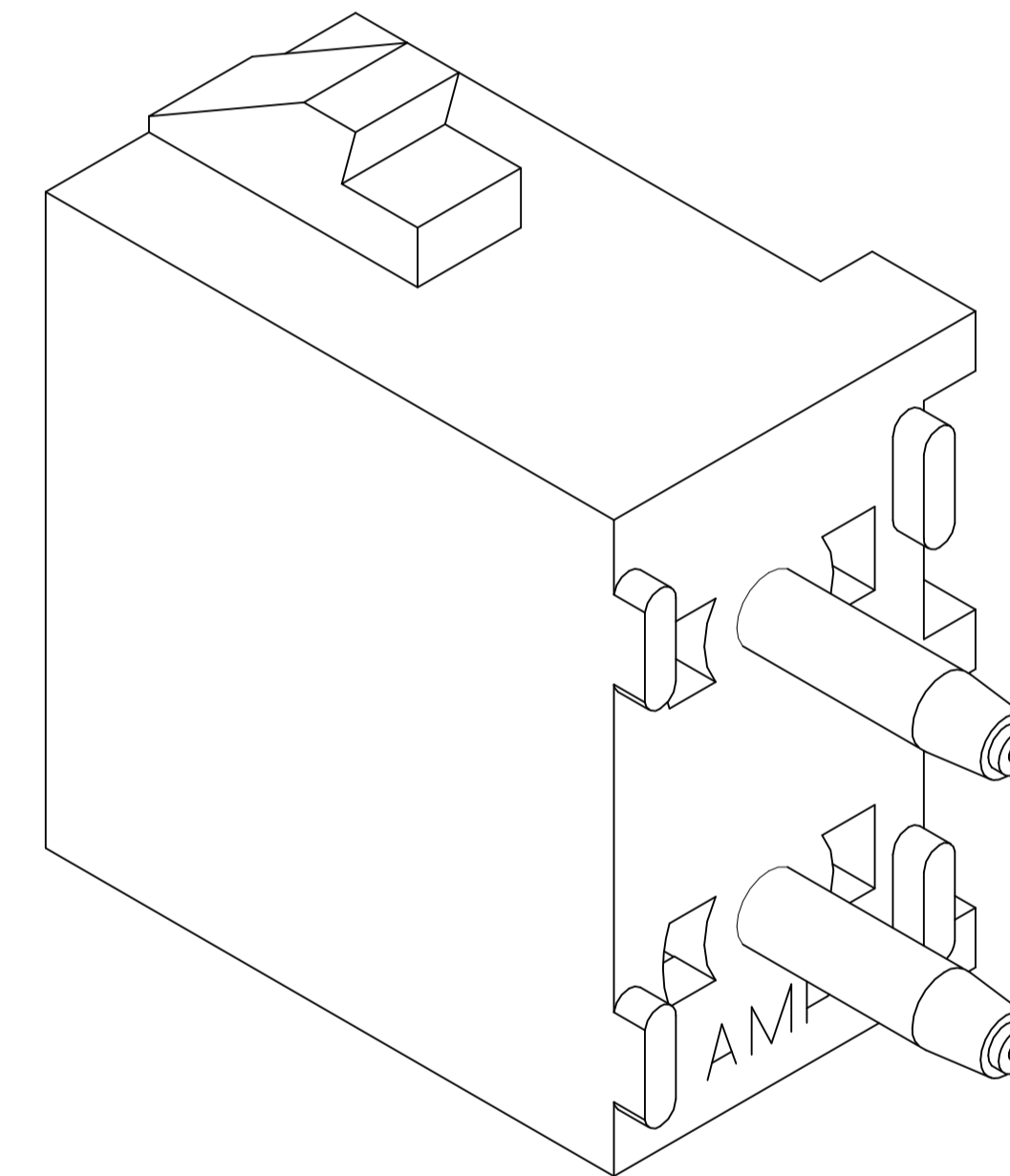

3-DIMENSIONAL MODEL
NTS

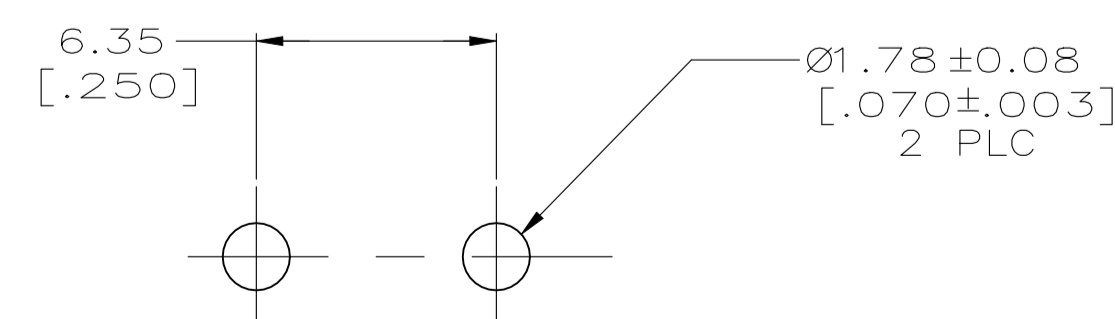
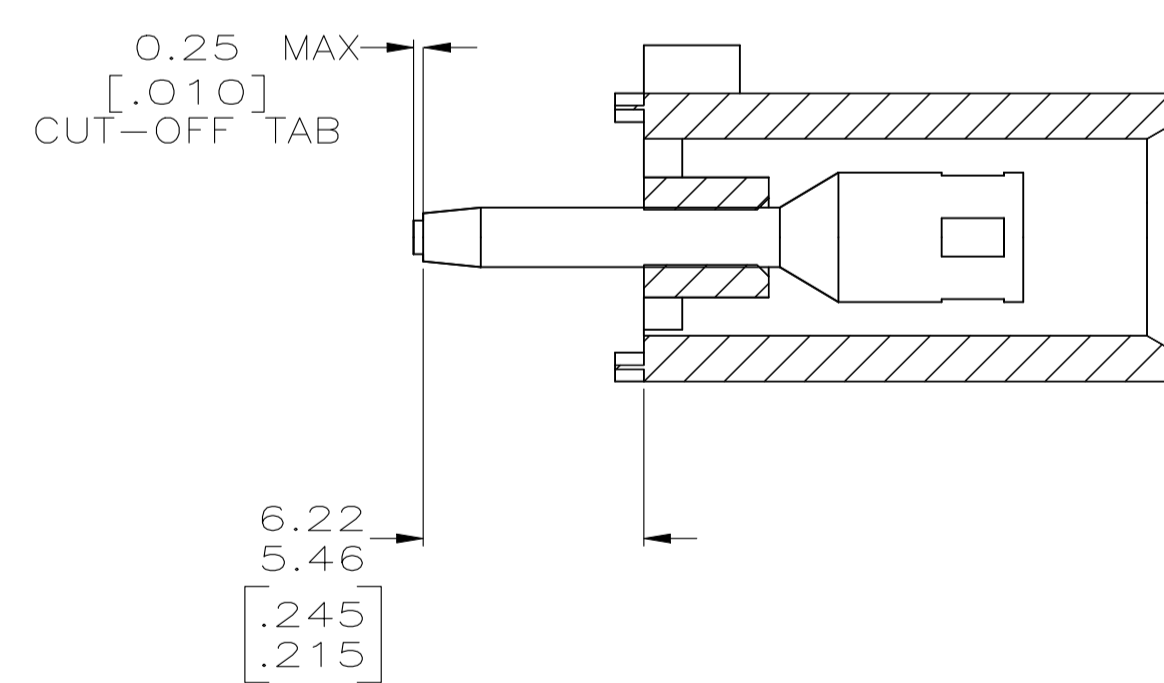

RECOMMENDED MOUNTING HOLE PATTERN
FOR 3.18 [.125] THICK P.C. BOARD

PHOSPHOR BRONZE, PRE-TIN		NYLON, UL94V-2, NATURAL		350986-4	
PIN CONTACT MATERIAL AND FINISH		HOUSING MATERIAL		PART NO	
THIS DRAWING IS A CONTROLLED DOCUMENT.		DIN 8-19-98		EJ LEWIS	
DIMENSIONS: mm [INCHES]		TOLERANCES UNLESS OTHERWISE SPECIFIED:		R SWING 8-19-98	
0 PLC ± -		1 PLC ± -		M TRULL 8-19-98	
1 PLC ± -		2 PLC ± 0.13 [.005]		NAME	
2 PLC ± -		3 PLC ± -		PRODUCT SPEC	
3 PLC ± -		4 PLC ± -		APPLICATION SPEC	
4 PLC ± -		ANGLES ± 90° 10°		SIZE	
MATERIAL SEE TABLE		FINISH SEE TABLE		CAGE CODE DRAWING NO	
				A1 00779 C=350986	
				RESTRICTED TO	
				WEIGHT	
				CUSTOMER DRAWING	
				SCALE 5:1 SHEET 1 OF 1 REV J1	

