

PART NUMBER	REVISION	DESCRIPTION	FEED TYPE
2151980-1	E	FINE CRIMP HEIGHT ADJUST	MECHANICAL
2151980-2	E	FINE CRIMP HEIGHT ADJUST	PNEUMATIC
7-2151980-1	E	MECHANICAL AND CRIMP TOOLING KIT	MECHANICAL
7-2151980-2	E	PNEUMATIC AND CRIMP TOOLING KIT	PNEUMATIC
7-2151980-7	C	CRIMP TOOLING KIT	-

ATLANTIC VERSION TERMINATOR INTERFACE ADAPTER

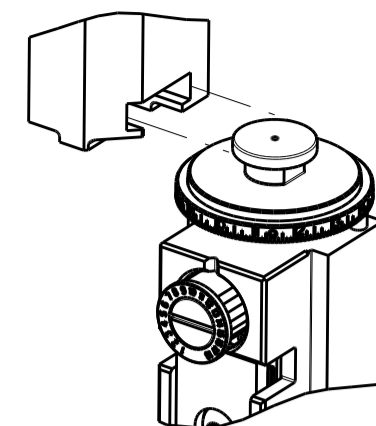

APPLICATOR DATA		
CRIMP	SIZE	TYPE
WIRE	1.40 mm [.055]	F
INSUL	1.57 mm [.062]	O

APPLICATOR INSTRUCTIONS 408-35042

TERMINAL DATA: TE TERMINAL		TE CRIMP SPECIFICATION	
TERMINAL NAME: CONTACT PIN			
WIRE STRIP LENGTH		INSULATION DIAMETER RANGE	
2.79-3.56 mm [.110-.140 IN]		Ø1.02-1.42 mm [.040-.056 IN]	
TERMINAL APPLICATION SPECIFICATION		TERMINAL APPLICATION SPECIFICATION	
114-16003			
TERMINALS APPLIED			
TE TERMINAL	TE TERMINAL	TE TERMINAL	TE TERMINAL
282618-1	86566-6	2-86566-0	86557-7
86566-2	86566-8	86557-4	1-86557-4
86566-4	1-86566-6	86557-6	1-86557-9

WIRE SIZE	CRIMP HEIGHT mm [INCH]	CRIMP HEIGHT REFERENCE SETTING
22 AWG	0.71 +/- 0.05 [.028 +/- .002]	6.1
24 AWG	0.62 +/- 0.05 [.024 +/- .002]	6.9
26 AWG	0.62 +/- 0.05 [.024 +/- .002]	7.1

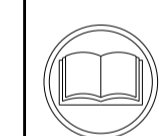

- 1 RECOMMENDED SPARE PARTS
  - 2 REFER TO SUPPLIED INSTRUCTION SHEET FOR CLEANING, LUBRICATION AND STORAGE OF APPLICATOR.
  - 3 APPLY PART NUMBER 2-23419-6 LOCTITE TO THREADS OF ITEM 242.
  - 4 CRIMP HEIGHT REFERENCE SETTING WAS THE SETTING USED WHEN THE APPLICATOR WAS QUALIFIED AT THE FACTORY. ADJUSTMENT MAY BE NECESSARY WHEN RUNNING APPLICATOR IN THE FIELD.
  - 5 WHEN RUNNING PIN TERMINALS 86557 AND 282618 INSTALL ITEMS 53 & 81.
  - 6 WHEN RUNNING SOCKET TERMINAL 86566 INSTALL ITEMS 57 & 7.
  - 7 TERMINAL LUBRICANT IS RECOMMENDED.
8. UNLESS SPECIFIED OTHERWISE TORQUE VALUES SHALL BE USED PER DOCUMENT, 101-35000.

**\*WARNING**  
ON INSTALLATION, SET WIRE DISC TO CRIMP HEIGHT REFERENCE SETTING FOR LARGEST WIRE SIZE. CRIMP HEIGHT REFERENCE SETTINGS GREATER THAN THE VALUE SHOWN MAY CAUSE DAMAGE TO THE CRIMP TOOLING, REFER TO THE INSTRUCTION SHEET FOR PROPER SETUP AND ADJUSTMENTS.

ATLANTIC VERSION  
Shown on sheets 1 of 4 & 2 of 4  
(Pacific version shown on sheets 3 of 4 & 4 of 4)

LOC	DIST	REVISIONS			
A	66	REV	DATE	BY	APPD
		C	ECR-14-017742	26NOV2014	LG GB
		D	ECR-17-003788	15MAR2017	TB TE
		E	ECR-19-009542	18JUN2019	FJ TE

-	1	1	1	1	2280441-1	INSERT, SHEAR	282	
-	1	-	1	-	2119640-1	PUSH ROD, AIR FEED	250	
-	1	-	1	-	1803259-1	BUSHING, FLANGED	249	
-	1	-	1	-	2119641-1	FEED CAM, AIR FEED	248	
-	1	1	1	1	2119082-9	CAM, SNAIL, INSULATION ADJUSTMENT	244	
-	1	1	1	1	2079764-1	WASHER, WAVE SPRING, CREST-TO-CREST	243	
3	-	1	1	1	2119083-1	RETAINER, INSULATION DIAL	242	
-	2	2	2	2	7-18023-7	SCR, SKT HD CAP M3 X 4.0	241	
-	-	1	-	1	2119580-1	MECHANICAL FEED ASSEMBLY	239	
-	1	-	1	-	2063440-1	AIR FEED MODULE	238	
-	2	-	2	-	21045-3	RING, RETAIN, EXTERN, 3/16 CRESCENT	172	
-	REF	REF	REF	REF	994970-2	COUNTER, MAGNETIC	164	
-	1	-	1	-	240638-1	SPRING, FEED FINGER	163	
-	1	-	1	-	3-23627-7	PIN, RETAIN, GRVD, 3/16 X .854	137	
-	1	-	1	-	2119799-1	HOLDER, FEED FINGER, AF	136	
-	2	2	2	2	1-18028-2	WASHER, FLAT, REG M4	119	
7	-	1	1	1	2119955-1	ASSY, LUBRICATOR, SIDE FEED	113	
-	1	1	1	1	2844908-1	SCREW, LOCKING	99	
-	1	1	1	1	2844907-1	POST, LOCKING	98	
-	1	1	1	1	455888-4	SPACER, CRIMPER	82	
5	-	1	1	1	5-240641-1	SPACER	81	
-	1	1	1	1	1803607-1	DOCUMENTATION PACKAGE	71	
-	1	1	1	1	2119740-1	TAG, IDENTIFICATION	67	
-	2	2	2	2	2168078-1	SCREW, DRIVE, RH, RoHS, 2 x .188	66	
-	1	1	1	1	2168083-2	SCR, SKT HD CAP, RoHS, M4 X 8.0	60	
-	1	1	1	1	5-18022-5	SCR, HEX HD CAP, M4 X 6.0	59	
6	-	2	2	2	2168083-8	SCR, SKT HD CAP, RoHS, M4 X 16	57	
-	1	1	1	1	1338685-1	PAWL, FEED	56	
-	4	4	4	4	2168083-3	SCR, SKT HD CAP, RoHS, M4 X 12.0	54	
5	-	2	2	2	2168083-9	SCR, SKT HD CAP, RoHS, M4 X 20	53	
-	1	2	1	2	18023-9	SCR, SKT HD CAP M4 X 6.0	49	
-	-	1	-	1	2119652-1	FEED CAM, PRE FEED	48	
-	-	1	-	1	2119653-1	FEED CAM, POST FEED	47	
-	1	1	1	1	1803583-9	APPLICATOR BASIC ASSEMBLY, SF	46	
-	1	1	1	1	1803515-1	RAM ASSEMBLY, SF ATLANTIC	44	
-	1	1	1	1	1803602-1	SCR, BHSC, RoHS (M8 X 25)	41	
-	2	2	2	2	2079383-5	SCR, BHSC, RoHS (M4 X 20)	33	
-	2	2	2	2	2-2844962-3	SPACER, CYLINDRICAL, STRIP GUIDE	30	
-	1	1	1	1	2844992-1	ASSEMBLY, STRIP GUIDE	29	
-	1	1	1	1	2119791-9	DEPRESSOR, WIRE	28	
-	1	1	1	1	1320928-2	STRIP GUIDE	24	
-	1	1	1	1	2168083-2	SCR, SKT HD CAP, RoHS, M4 X 8.0	21	
-	1	1	1	1	1-18028-2	WASHER, FLAT, REG M4	20	
-	1	1	1	1	2119533-1	STRIPPER, SIDE FEED	19	
-	1	1	1	1	5-690518-0	HOLD DOWN, TERMINAL	18	
-	1	1	1	1	690463-1	FLOATING SHEAR, REAR	17	
-	2	2	2	2	1-2168083-1	SCR, SKT HD CAP, RoHS, M3 X 6	16	
-	1	1	1	1	2-690464-4	SHEAR PLATE, REAR	15	
-	1	1	1	1	2119862-1	SHEAR HOLDER, REAR	14	
-	1	1	1	1	2119806-1	INSERT, SHEAR	13	
-	2	2	2	2	3-22280-3	SPRING, COMPRESSION	12	
-	2	2	2	2	1-356885-4	STOP, SHEAR	11	
1	-	1	1	1	2119805-1	SHEAR HOLDER, FRONT	10	
1	-	1	1	1	1803095-6	FLOATING SHEAR, FRONT	9	
1	1	2	2	1	1	3-1633932-2	ANVIL, COMBINATION	8
6	-	1	1	1	1	6-240641-9	SPACER	7
-	1	1	1	1	1	690468-1	DEPRESSOR SHEAR, REAR	6
-	1	1	1	1	1	2119757-4	DEPRESSOR, SHEAR	5
-	1	1	1	1	1	2-238011-2	BLOCK, CRIMPER SPACER	4
1	1	2	2	1	1	2-1633966-3	CRIMPER, INSULATION O	3
-	-	-	-	-	-	-	-	2
1	1	2	2	1	1	6-456402-5	CRIMPER, WIRE PREMIUM	1
-	-	-	-	-	-	-	-	1

DIMENSIONS:		TOLERANCES UNLESS OTHERWISE SPECIFIED:		MATERIAL:		FINISH:	
mm	0 PLC ±	1 PLC ±	2 PLC ±	3 PLC ±	4 PLC ±	ANGLES ±	FINISH

OWN	Y. YIN	19JUN2013		TE Connectivity
CHK	G. BAILEY	19JUN2013		Harrisburg, PA 17105-3608
APVD	J. GUO	19JUN2013	NAME	Ocean Side Feed Applicator
PRODUCT SPEC				
APPLICATION SPEC				
SIZE	CAGE CODE	DRAWING NO	RESTRICTED TO	
A1	00779	2151980		
Customer Accessible Production Drawing			SCALE	1:2
			SHEET	1 of 4
			REV	E

LOC	DIST	REV	DATE	BY	APPV
A	66				

### FEED TYPE MECHANICAL



### PNEUMATIC

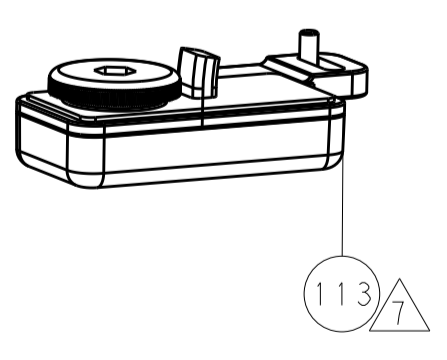
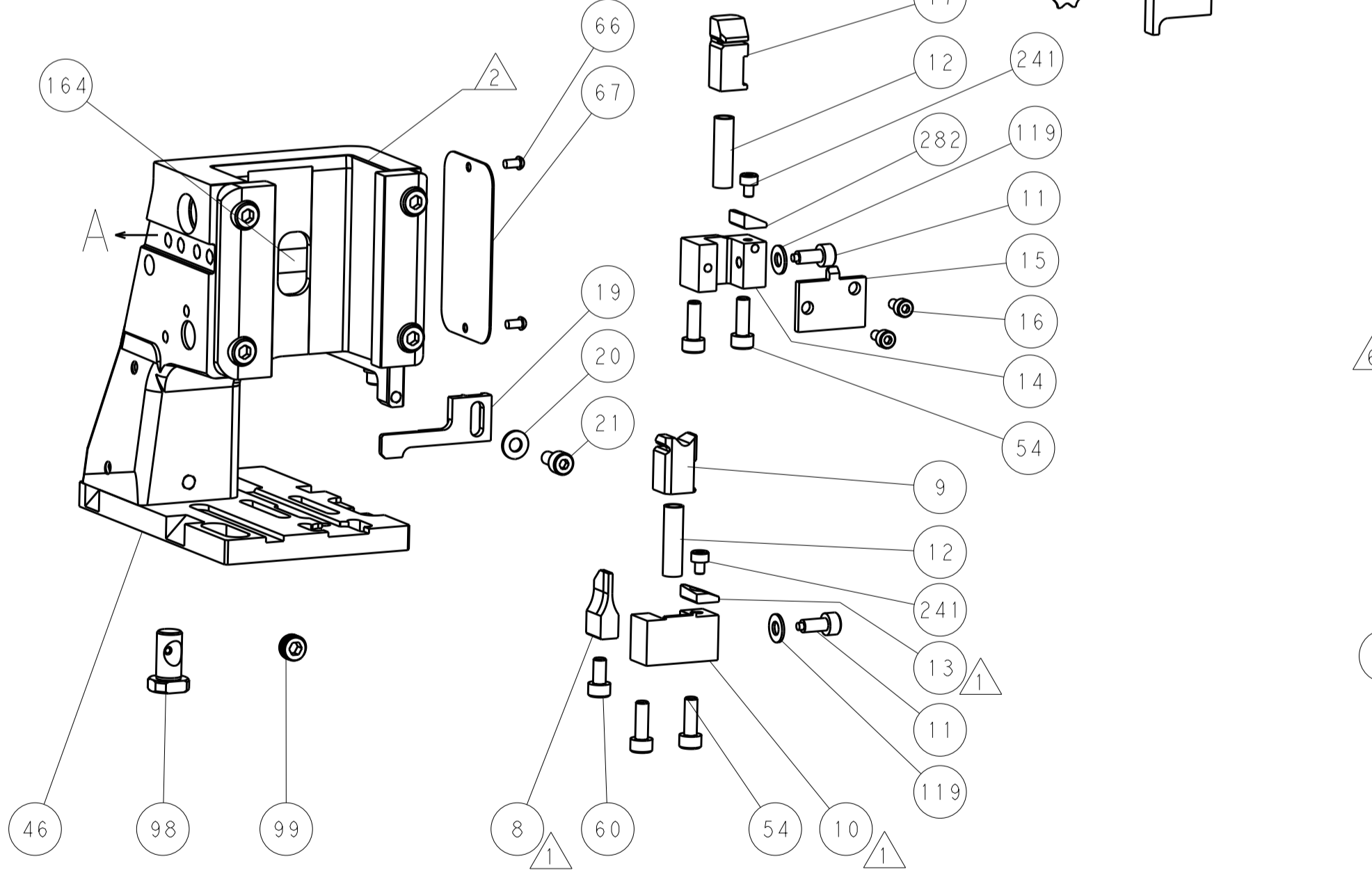
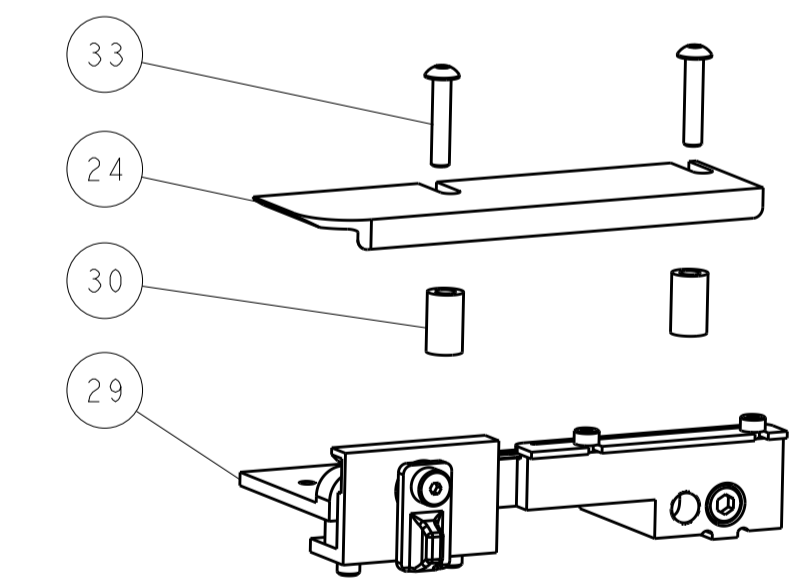
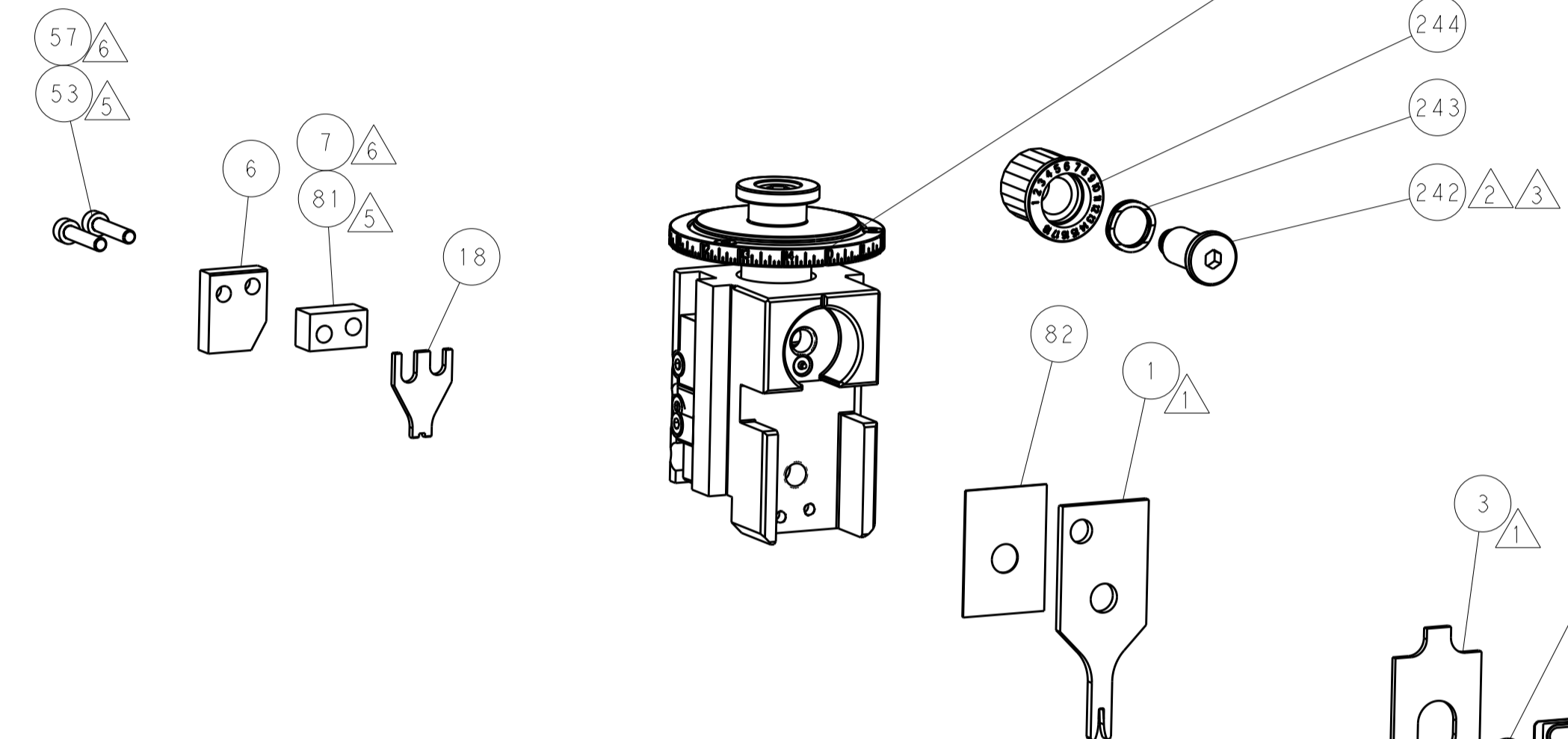
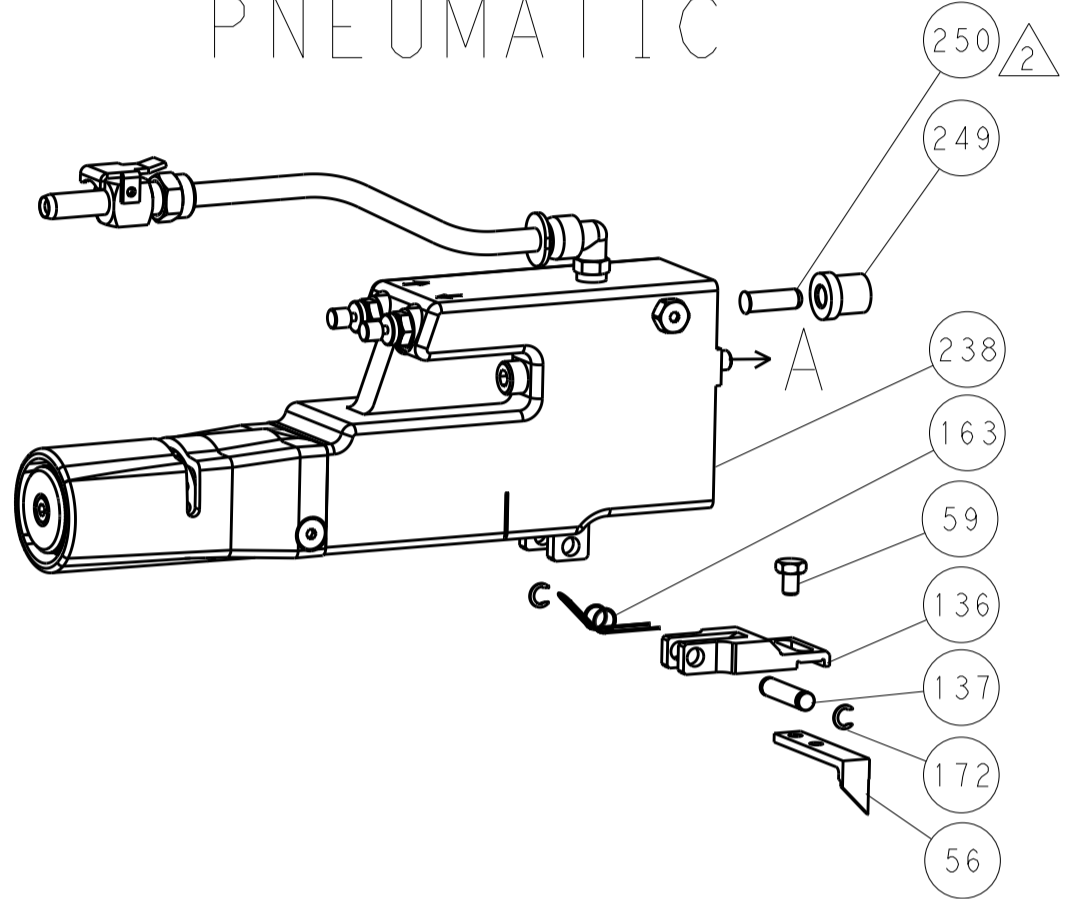

### CAM POSITIONS

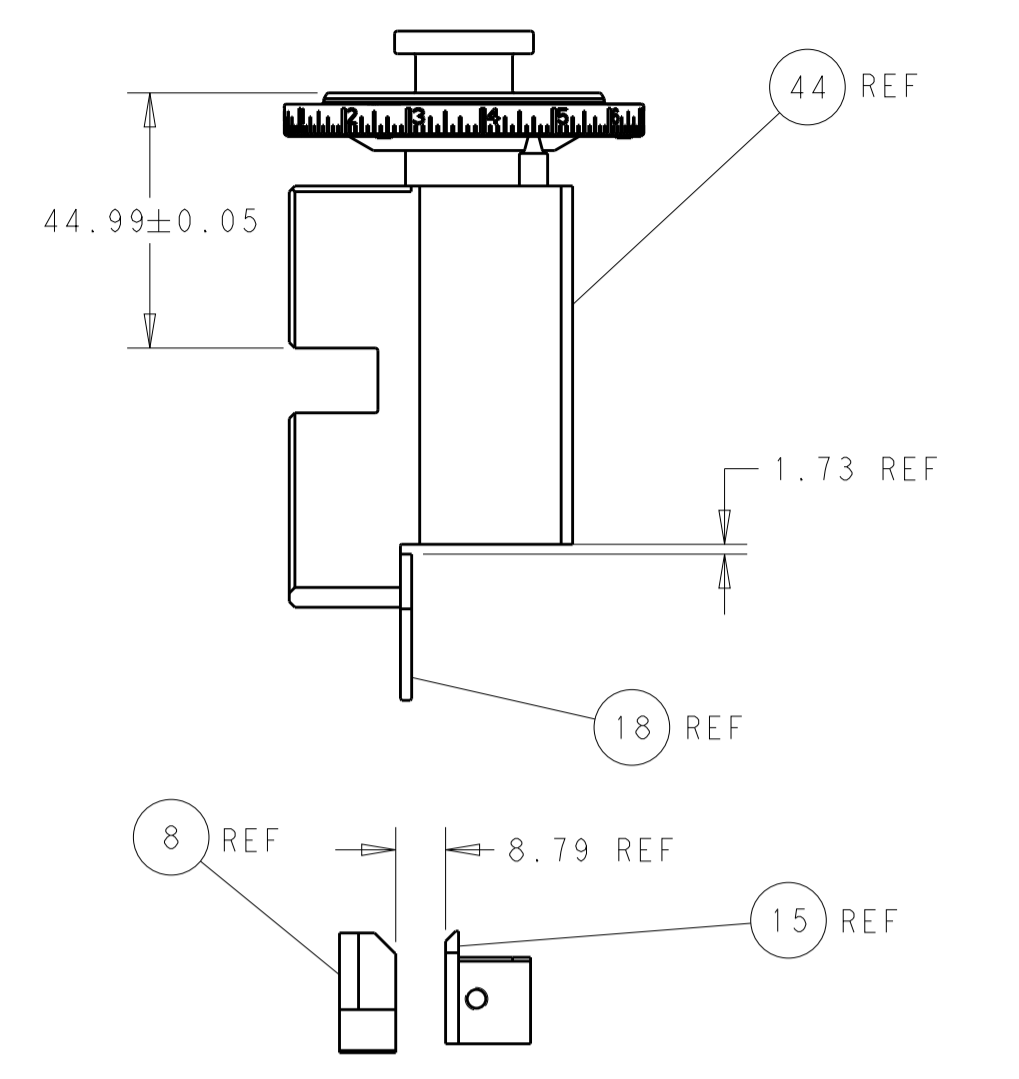
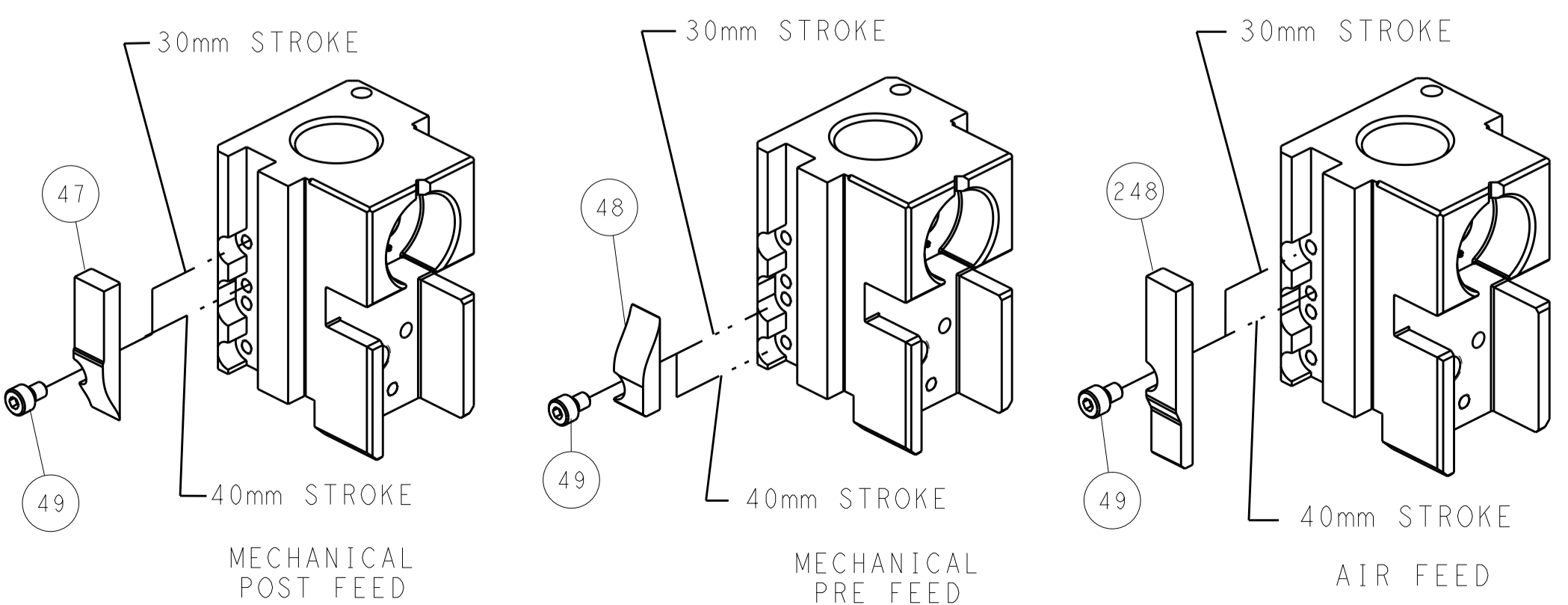

5 TERMINAL HOLD DOWN & REAR SHEAR TOOLING LOCATION FOR PIN TERMINALS 86557 & 282618 ONLY

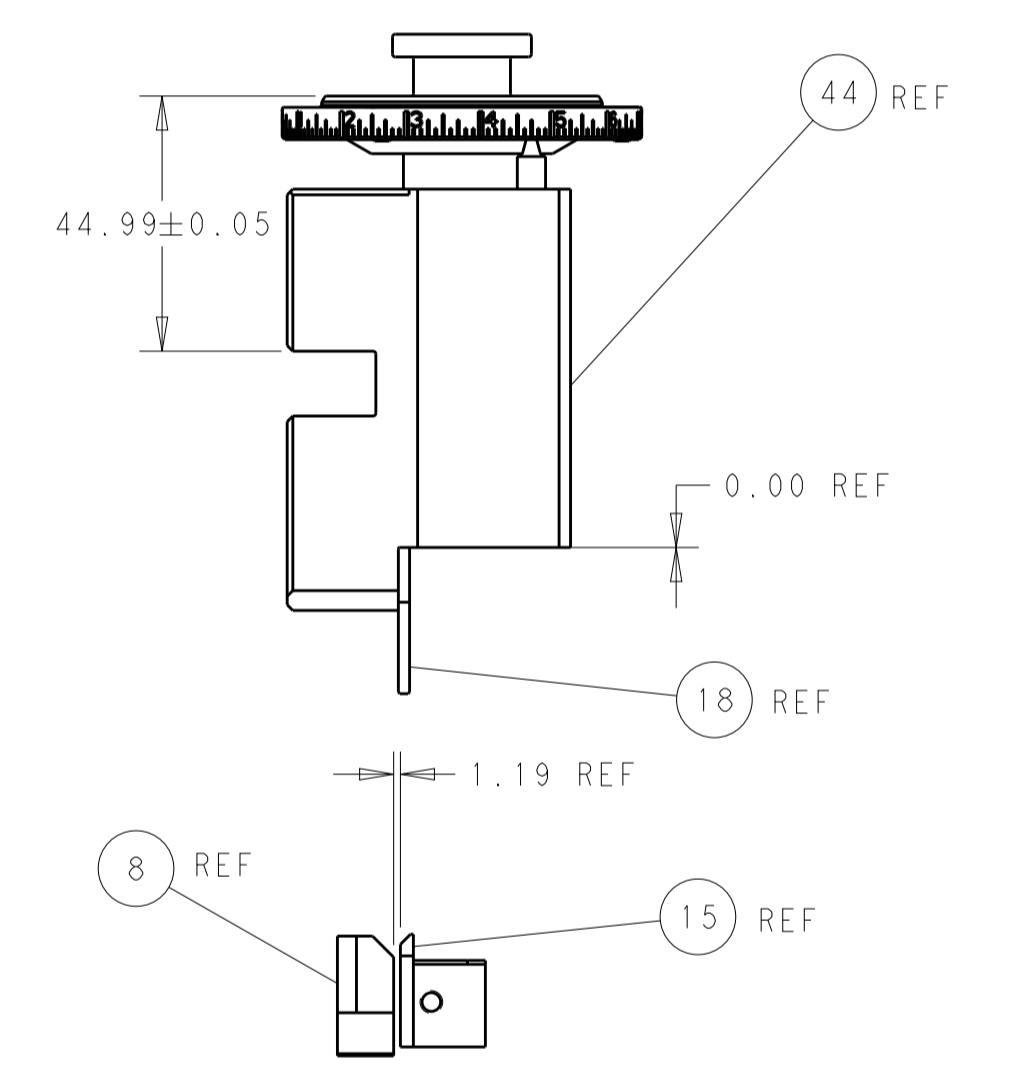

6 TERMINAL HOLD DOWN & REAR SHEAR TOOLING LOCATION FOR SOCKET TERMINAL 86566 ONLY

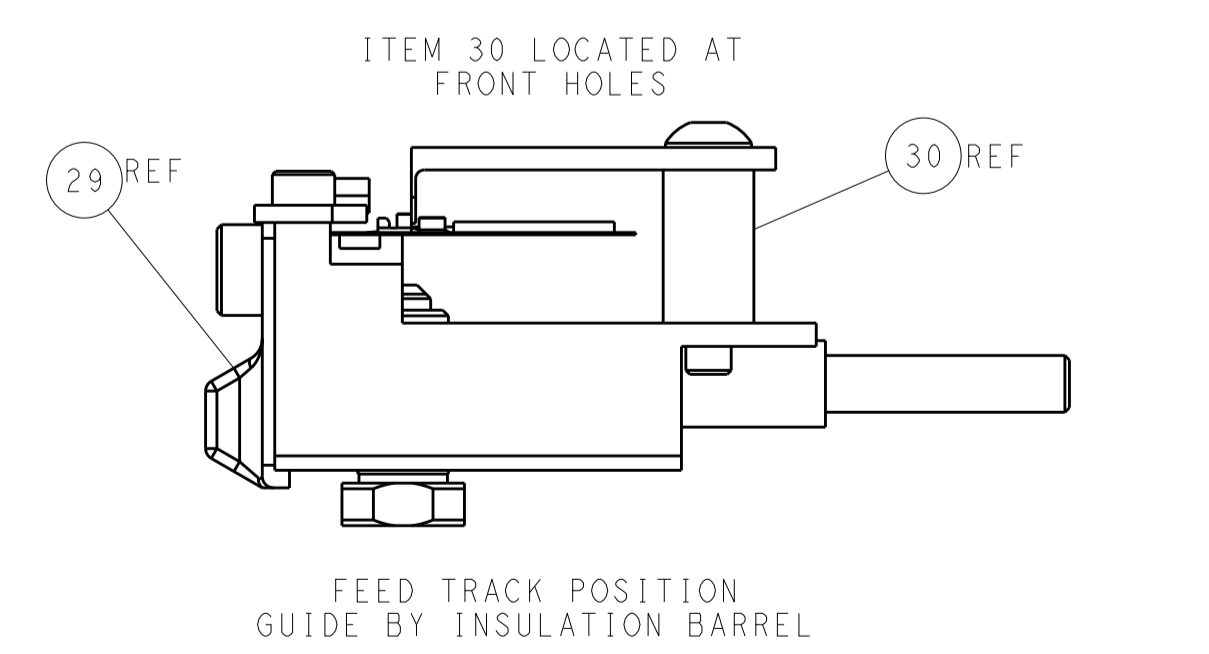

**ATLANTIC VERSION**  
 Shown on sheets 1 of 4 & 2 of 4  
 (Pacific version shown on sheets 3 of 4 & 4 of 4)

DIMENSIONS:		TOLERANCES UNLESS OTHERWISE SPECIFIED:		DWG: Y. YIN 19JUN2013		TE Connectivity	
mm	0 PLC	±		CHK: G. BAILEY 19JUN2013	NAME: Ocean Side Feed Applicator		Harrisburg, PA 17105-3608
	1 PLC	±		APPV: H. GUO 19JUN2013	RESTRICTED TO:		
	2 PLC	±		PRODUCT SPEC		SCALE: 1:2 SHEET 2 OF 4 REV E	
	3 PLC	±		APPLICATION SPEC		CAGE CODE: 00779	
	4 PLC	±		WEIGHT		DRAWING NO: 2151980	
	ANGLES	±		MATERIAL		Customer Accessible Production Drawing	

PART NUMBER	REVISION	DESCRIPTION	FEED TYPE
2-2151980-1	E	FINE CRIMP HEIGHT ADJUST	MECHANICAL
2-2151980-2	E	FINE CRIMP HEIGHT ADJUST	PNEUMATIC
7-2151980-7	C	CRIMP TOOLING KIT	-

PACIFIC VERSION TERMINATOR  
INTERFACE ADAPTER



APPLICATOR DATA		
CRIMP	SIZE	TYPE
WIRE	1.40 mm [.055]	F
INSUL	1.57 mm [.062]	O
APPLICATOR INSTRUCTIONS 408-35042		

TERMINAL DATA: TE TERMINAL		TE CRIMP SPECIFICATION	
TERMINAL NAME: CONTACT PIN			
WIRE STRIP LENGTH	INSULATION DIAMETER RANGE		
2.79-3.56 mm [.110-.140 IN]	Ø1.02-1.42 mm [.040-.056 IN]		
TERMINAL APPLICATION SPECIFICATION	114-16003		
TERMINALS APPLIED			
TE TERMINAL	TE TERMINAL	TE TERMINAL	TE TERMINAL
282618-1	86566-6	2-86566-0	86557-7
86566-2	86566-8	86557-4	1-86557-4
86566-4	1-86566-6	86557-6	1-86557-9

WIRE SIZE	CRIMP HEIGHT mm [INCH]	CRIMP HEIGHT REFERENCE SETTING
22 AWG	0.71+/-0.05 [.028+/-0.002]	6.1
24 AWG	0.62+/-0.05 [.024+/-0.002]	6.9
26 AWG	0.62+/-0.05 [.024+/-0.002]	7.1

- RECOMMENDED SPARE PARTS
  - REFER TO SUPPLIED INSTRUCTION SHEET FOR CLEANING, LUBRICATION AND STORAGE OF APPLICATOR.
  - APPLY PART NUMBER 2-23419-6 LOCTITE TO THREADS OF ITEM 242.
  - CRIMP HEIGHT REFERENCE SETTING WAS THE SETTING USED WHEN THE APPLICATOR WAS QUALIFIED AT THE FACTORY. ADJUSTMENT MAY BE NECESSARY WHEN RUNNING APPLICATOR IN THE FIELD.
  - WHEN RUNNING PIN TERMINALS 86557 AND 282618 INSTALL ITEMS 53 & 81.
  - WHEN RUNNING SOCKET TERMINAL 86566 INSTALL ITEMS 57 & 7.
  - TERMINAL LUBRICANT IS RECOMMENDED.
8. UNLESS SPECIFIED OTHERWISE TORQUE VALUES SHALL BE USED PER DOCUMENT, 101-35000.

**\*WARNING**  
ON INSTALLATION, SET WIRE DISC TO CRIMP HEIGHT REFERENCE SETTING FOR LARGEST WIRE SIZE. CRIMP HEIGHT REFERENCE SETTINGS GREATER THAN THE VALUE SHOWN MAY CAUSE DAMAGE TO THE CRIMP TOOLING, REFER TO THE INSTRUCTION SHEET FOR PROPER SETUP AND ADJUSTMENTS.

PACIFIC VERSION  
Shown on sheets 3 of 4 & 4 of 4  
(Atlantic version shown on sheets 1 of 4 & 2 of 4)

LOC	DIST	REVISIONS					
A	66	P	LTN	DESCRIPTION	DATE	OWN	APVD
-	-	-	-	SEE SHEET 1	-	-	-

-	1	1	2280441-1	INSERT, SHEAR	282
-	1	-	2119640-1	PUSH ROD, AIR FEED	250
-	1	-	1803259-1	BUSHING, FLANGED	249
-	1	1	2119082-9	CAM, SWAIL, INSULATION ADJUSTMENT	244
-	1	1	2079764-1	WASHER, WAVE SPRING, CREST-TO-CREST	243
-	1	1	2119083-1	RETAINER, INSULATION DIAL	242
-	2	2	7-18023-7	SCR, SKT HD CAP M3 X 4.0	241
-	-	1	2119580-1	MECHANICAL FEED ASSEMBLY	239
-	1	-	2063440-1	AIR FEED MODULE	238
-	2	-	21045-3	RING, RETAIN, EXTERN, 3/16 CRESCENT	172
-	REF	REF	994970-2	COUNTER, MAGNETIC	164
-	1	-	240638-1	SPRING, FEED FINGER	163
-	1	-	2119641-2	FEED CAM, AIR FEED	151
-	1	1	2168083-8	SCR, SKT HD CAP, RoHS, M4 X 16	144
-	4	4	2168083-9	SCR, SKT HD CAP, RoHS, M4 X 20	143
-	-	1	2119653-2	FEED CAM, POST FEED	142
-	1	1	1-1803583-0	APPLICATOR BASIC ASSEMBLY, SF	141
-	1	1	1803516-1	RAM ASSEMBLY, SF PACIFIC	140
-	1	-	3-23627-7	PIN, RETAIN, GRVD, 3/16 X .854	137
-	1	-	2119799-1	HOLDER, FEED FINGER, AF	136
-	2	2	1-18028-2	WASHER, FLAT, REG M4	119
-	1	1	2119955-1	ASSY, LUBRICATOR, SIDE FEED	113
-	1	1	2844908-1	SCREW, LOCKING	99
-	1	1	2844907-1	POST, LOCKING	98
-	1	1	455888-4	SPACER, CRIMPER	82
-	1	1	5-240641-1	SPACER	81
-	1	1	1803607-1	DOCUMENTATION PACKAGE	71
-	1	1	2119740-1	TAG, IDENTIFICATION	67
-	2	2	2168078-1	SCREW, DRIVE, RH, RoHS, 2 x .188	66
-	1	1	5-18022-5	SCR, HEX HD CAP, M4 X 6.0	59
-	2	2	2168083-8	SCR, SKT HD CAP, RoHS, M4 X 16	57
-	1	1	1338685-1	PAWL, FEED	56
-	2	2	2168083-9	SCR, SKT HD CAP, RoHS, M4 X 20	53
-	1	2	18023-9	SCR, SKT HD CAP M4 X 6.0	49
-	-	1	2119652-1	FEED CAM, PRE FEED	48
-	1	1	1803602-1	SCR, BHSC, RoHS (M8 X 25)	41
-	2	2	2079383-5	SCR, BHSC, RoHS (M4 X 20)	33
-	2	2	2-2844962-3	SPACER, CYLINDRICAL, STRIP GUIDE	30
-	1	1	2844992-1	ASSEMBLY, STRIP GUIDE	29
-	1	1	2119791-9	DEPRESSOR, WIRE	28
-	1	1	1320928-2	STRIP GUIDE	24
-	1	1	2168083-2	SCR, SKT HD CAP, RoHS, M4 X 8.0	21
-	1	1	1-18028-2	WASHER, FLAT, REG M4	20
-	1	1	2119533-1	STRIPPER, SIDE FEED	19
-	1	1	5-690518-0	HOLD DOWN, TERMINAL	18
-	1	1	690463-1	FLOATING SHEAR, REAR	17
-	2	2	1-2168083-1	SCR, SKT HD CAP, RoHS, M3 X 6	16
-	1	1	2-690464-4	SHEAR PLATE, REAR	15
-	1	1	2119862-1	SHEAR HOLDER, REAR	14
-	1	1	2119806-1	INSERT, SHEAR	13
-	2	2	3-22280-3	SPRING, COMPRESSION	12
-	2	2	1-356885-4	STOP, SHEAR	11
-	1	1	2119805-1	SHEAR HOLDER, FRONT	10
-	1	1	1803095-6	FLOATING SHEAR, FRONT	9
-	1	1	3-1633932-2	ANVIL, COMBINATION	8
-	1	1	6-240641-9	SPACER	7
-	1	1	690468-1	DEPRESSOR SHEAR, REAR	6
-	1	1	2119757-4	DEPRESSOR, SHEAR	5
-	1	1	2-238011-2	BLOCK, CRIMPER SPACER	4
-	1	1	2-1633966-3	CRIMPER, INSULATION O	3
-	-	-	-	-	2
-	1	1	6-456402-5	CRIMPER, WIRE PREMIUM	1

DIMENSIONS:		TOLERANCES UNLESS OTHERWISE SPECIFIED:		MATERIAL:		FINISH:	
mm	0 PLC ±	1 PLC ±	2 PLC ±	3 PLC ±	4 PLC ±	ANGLES	

DATE	BY	CHKD	APVD	NAME	SIZE	CAGE CODE	DRAWING NO	RESTRICTED TO
19JUN2013	Y. YIN	19JUN2013	G. BAILEY	TE Connectivity Harrisburg, PA 17105-3608	A1	00779	2151980	
Customer Accessible Production Drawing								SCALE 1:2 SHEET 3 OF 4 REV E

LOC		DIST		REVISIONS			
A	66	P	LTM	DESCRIPTION	DATE	DMN	APVD
				SEE SHEET 1			

# FEED TYPE MECHANICAL



# PNEUMATIC

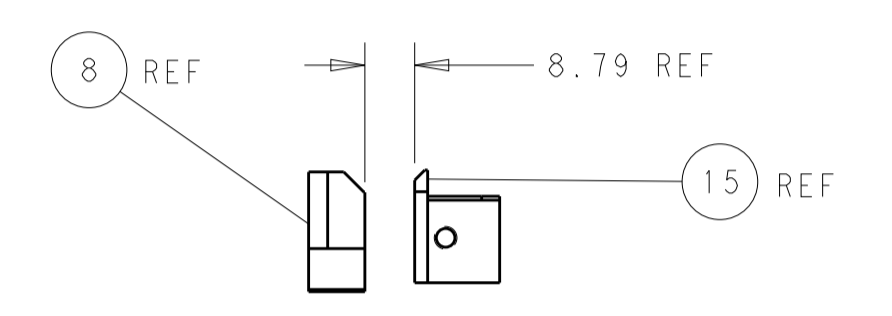
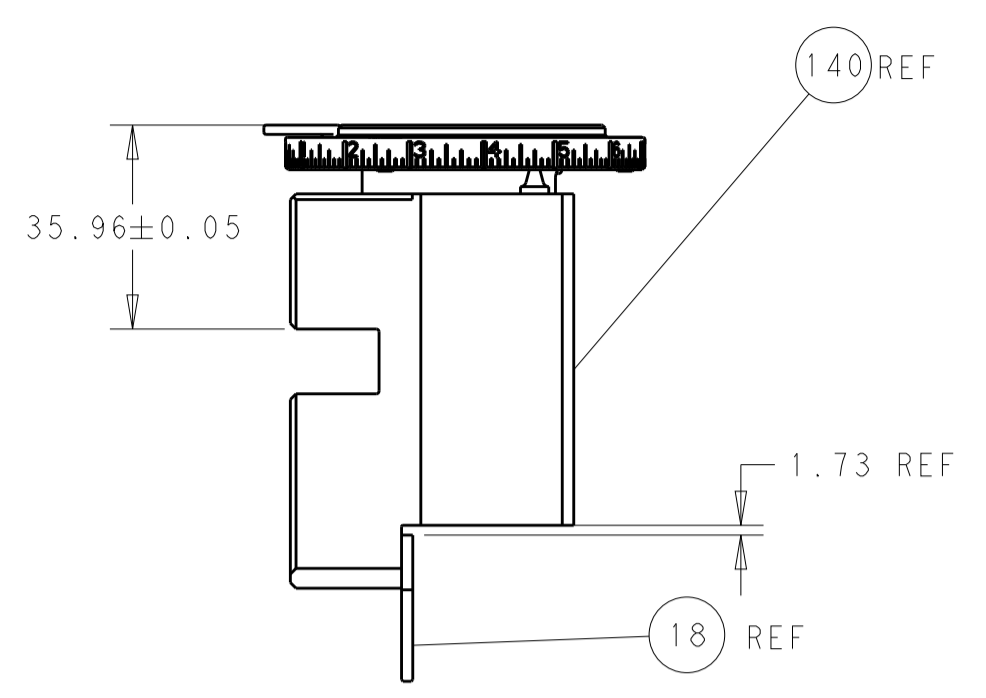
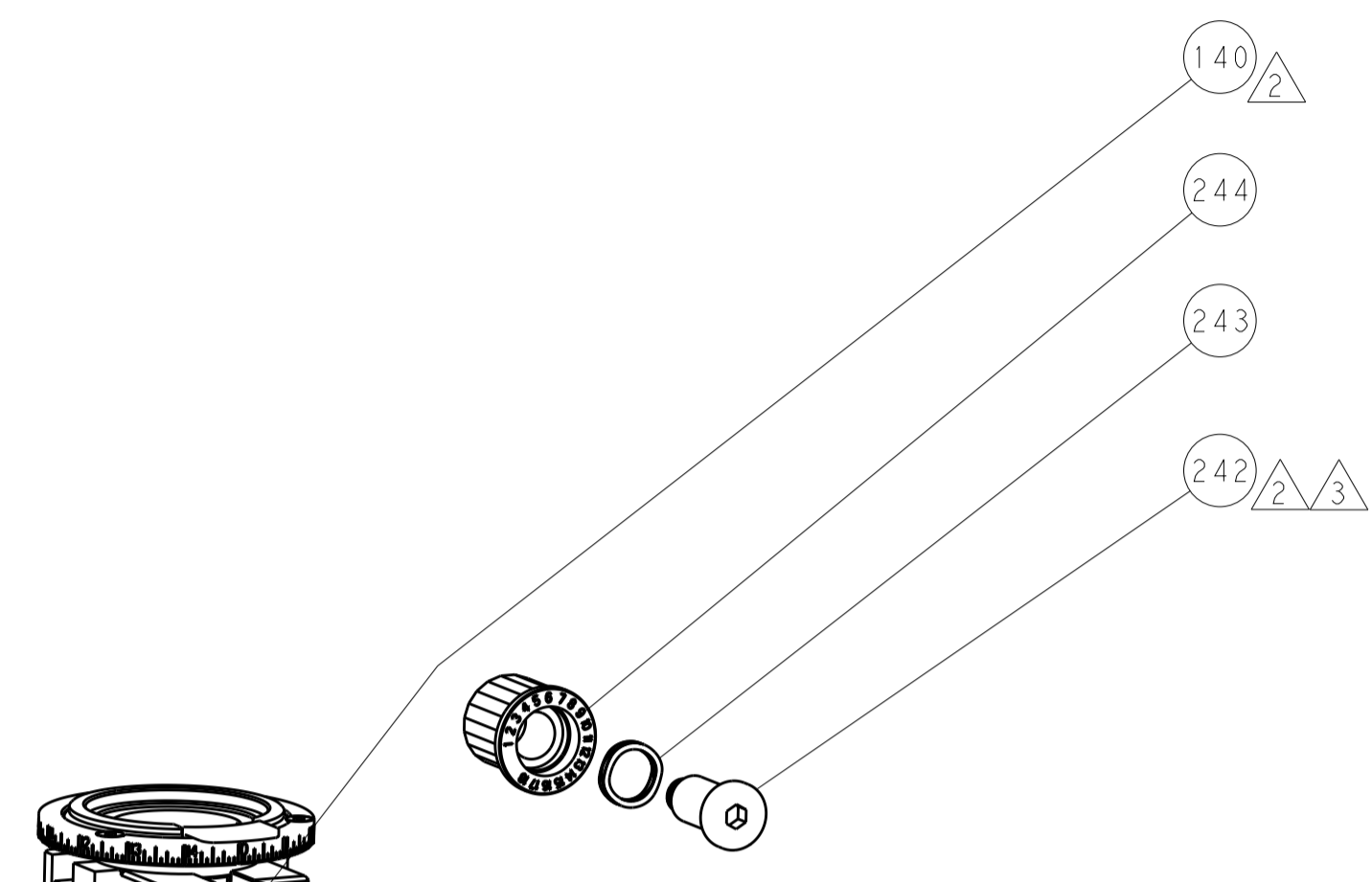
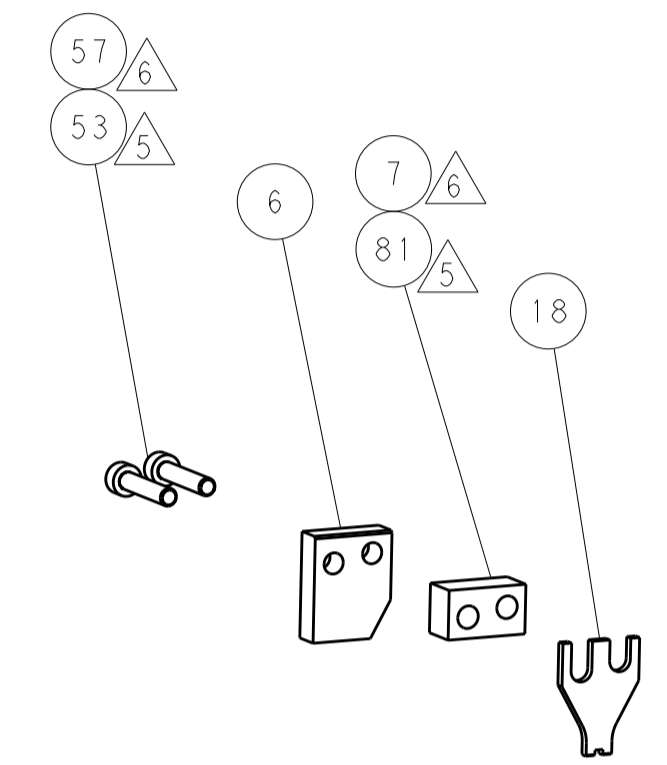
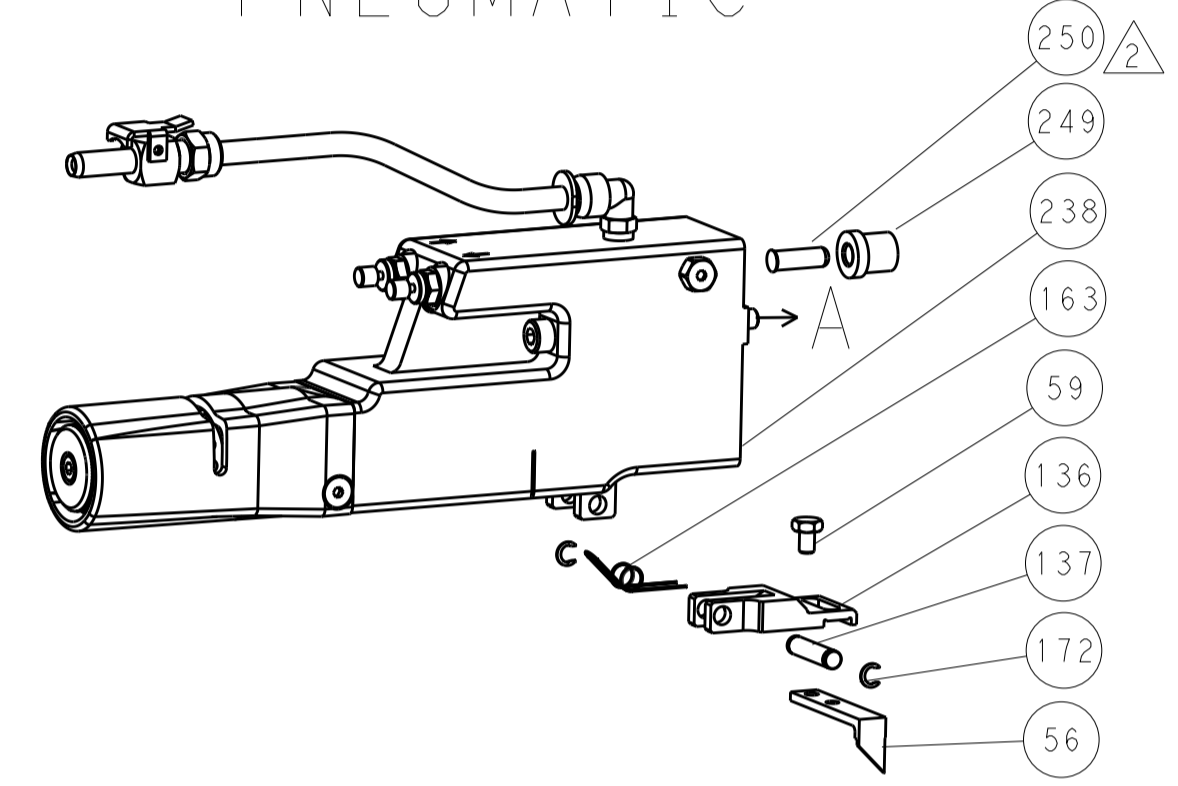

△ TERMINAL HOLD DOWN & REAR SHEAR TOOLING LOCATION FOR PIN TERMINALS 86557 & 282618 ONLY

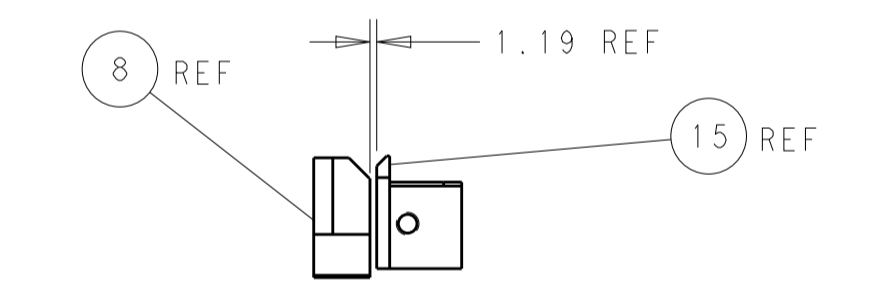
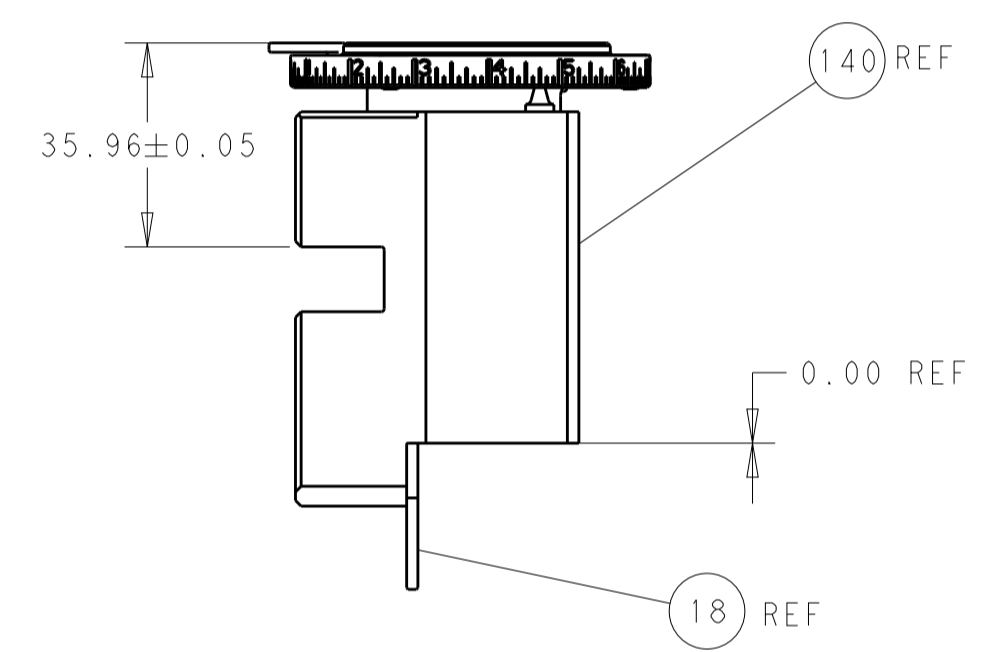

△ TERMINAL HOLD DOWN & REAR SHEAR TOOLING LOCATION FOR SOCKET TERMINAL 86566 ONLY

ITEM 30 LOCATED AT FRONT HOLES

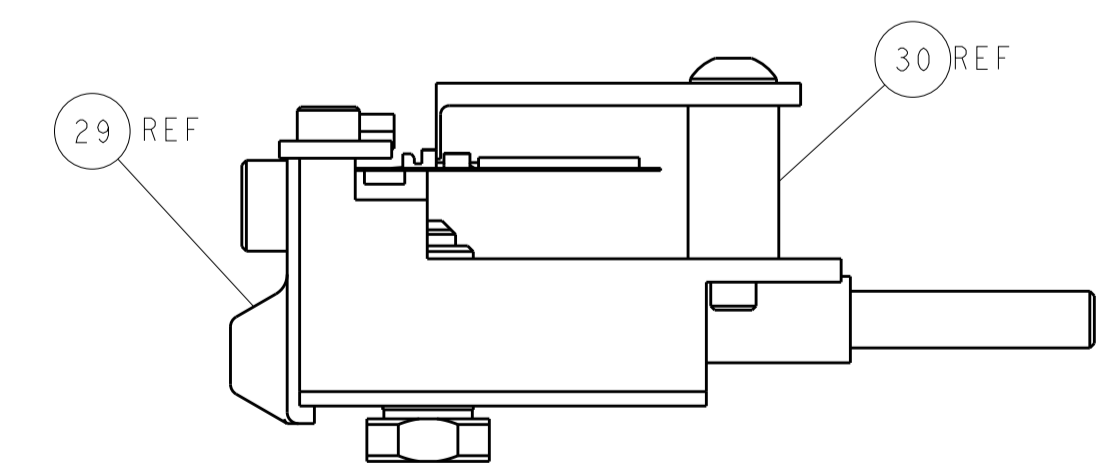

FEED TRACK POSITION GUIDE BY INSULATION BARREL

# CAM POSITIONS

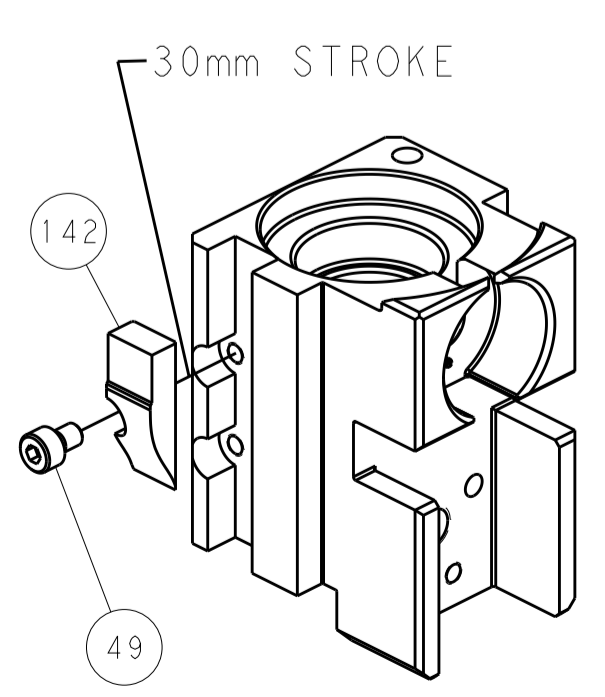

MECHANICAL POST FEED

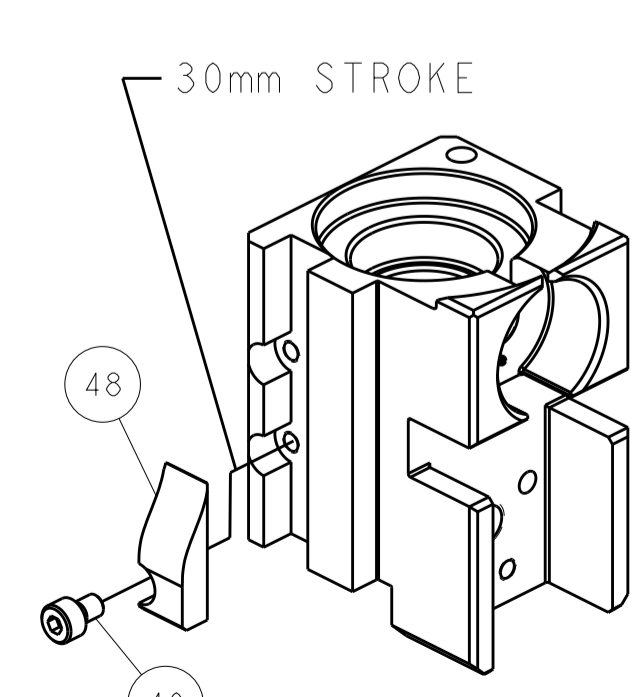

MECHANICAL PRE FEED

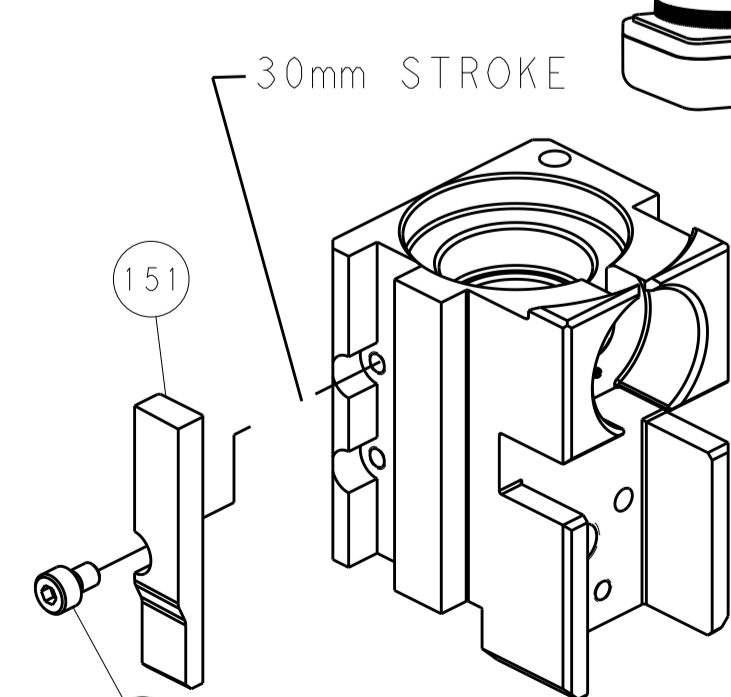

AIR FEED

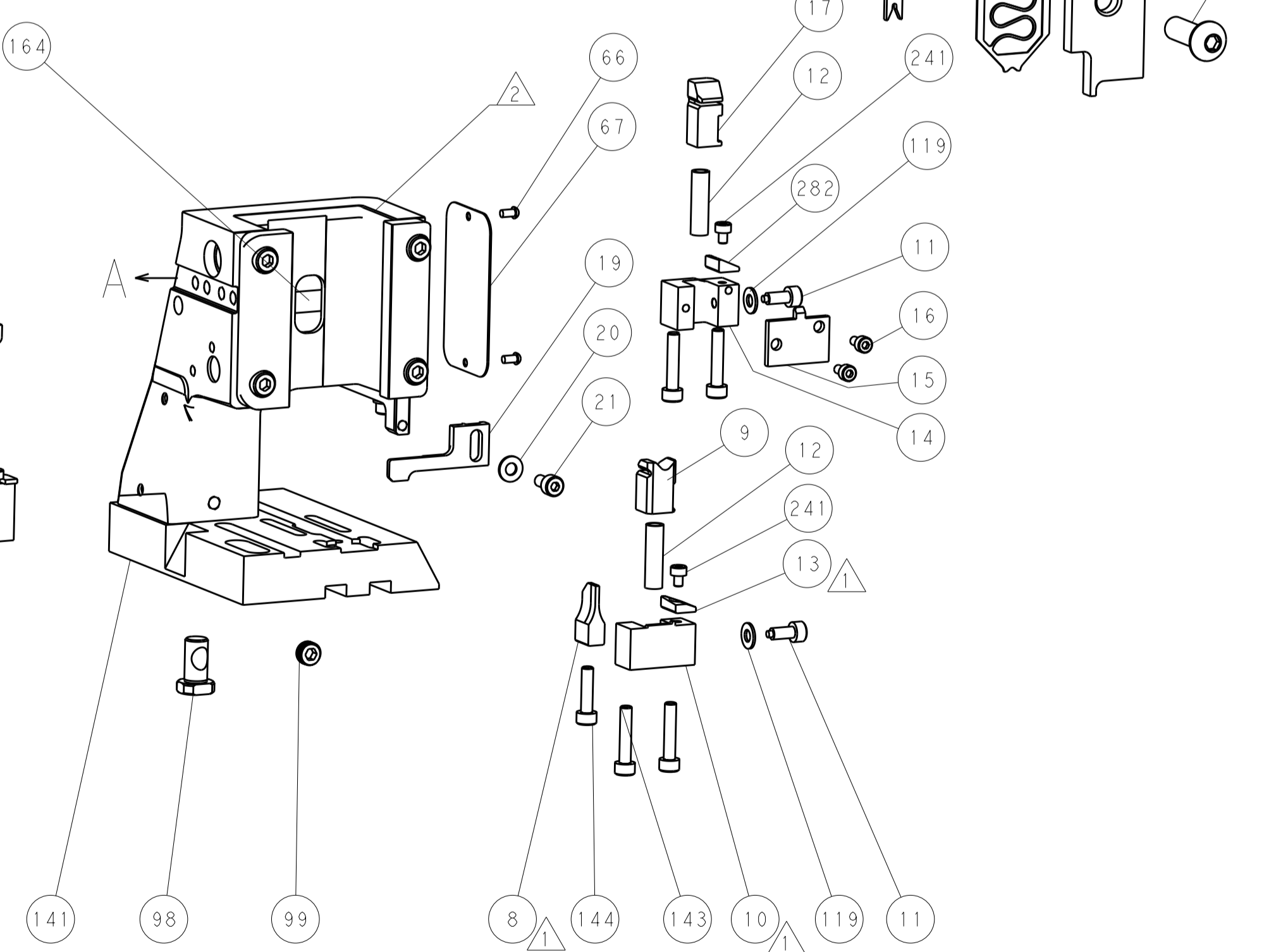
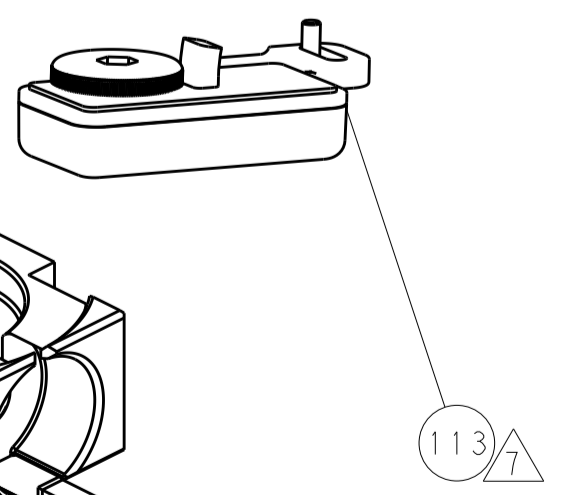

**PACIFIC VERSION**  
 Shown on sheets 3 of 4 & 4 of 4  
 (Atlantic version shown on sheets 1 of 4 & 2 of 4)

DIMENSIONS:		TOLERANCES UNLESS OTHERWISE SPECIFIED:		DWG: Y. YIN 19JUN2013		TE Connectivity	
mm	0 PLC ±	1 PLC ±	2 PLC ±	3 PLC ±	4 PLC ±	5 PLC ±	Harrisburg, PA 17105-3608
	ANGLES	FINISH		CHK: G. BAILEY 19JUN2013	NAME: Ocean Side Feed Applicator	RESTRICTED TO	
MATERIAL				APVD: H. GUO 19JUN2013	PRODUCT SPEC	SIZE	CAGE CODE DRAWING NO
					APPLICATION SPEC	WT	00779 C=2151980
					WEIGHT	SCALE	1:2 SHEET 4 OF 4 REV E
					Customer Accessible Production Drawing		