

PCA9701; PCA9702

18 V tolerant SPI 16-bit/8-bit GPI with $\overline{\text{INT}}$

Rev. 7 — 26 September 2014

Product data sheet

1. General description

The PCA9701/PCA9702 are low power 18 V tolerant SPI General Purpose Input (GPI) shift register designed to monitor the status of switch inputs. It generates an interrupt when one or more of the switch inputs change state. The input level is recognized as a HIGH when it is greater than $0.7 \times V_{DD}$ and as a LOW when it is less than $0.4 \times V_{DD}$ (minimum threshold of 2 V at 5 V node). The PCA9701 can monitor up to 16 switch inputs and the PCA9702 can monitor up to 8 switch inputs.

The falling edge of the $\overline{\text{CS}}$ pin samples the input port status and clears the interrupt. When $\overline{\text{CS}}$ is LOW, the rising edge of the SCLK loads the shift register and shifts the value out of the shift register. The serial input is sampled on the falling edge of SCLK.

Each of the input ports has a 18 V breakdown ESD protection circuit. When used with a series resistor (minimum 100 k Ω), the input can connect to a 12 V battery and support double battery, reverse battery, 27 V jump start and 40 V load dump conditions in automotive applications. Higher voltages can be tolerated on the inputs depending on the series resistor used to limit the input current.

With both the high breakdown voltage and high ESD, these devices are useful for both automotive and mobile applications.

The PCA9703/PCA9704 are new pin compatible devices for the PCA9701/PCA9702 which have an interrupt masking feature allowing selected inputs to not generate interrupts and provides higher ground offset of $0.55 \times V_{DD}$ (minimum of 2.5 V at 5 V node) with minimum hysteresis of $0.05 \times V_{DD}$ (minimum of 225 mV at 5 V node).

2. Features and benefits

- 16 general purpose input ports (PCA9701) or 8 general purpose input ports (PCA9702)
- 18 V tolerant input ports with 100 k Ω external series resistor
- Input LOW threshold $0.4 \times V_{DD}$ with minimum of 2 V at $V_{DD} = 4.5$ V
- Open-drain interrupt output
- Interrupt enable pin (INT_EN) disables interrupt output
- V_{DD} range: 2.5 V to 5.5 V
- I_{DD} is very low 2.5 μA maximum
- SPI serial interface with speeds up to 5 MHz
- ESD protection exceeds 8 kV HBM per JESD22-A114, 350 V MM, and 1000 V CDM per JESD22-C101
- Latch-up testing is done to JEDEC Standard JESD78 which exceeds 100 mA
- Operating temperature range: -40 °C to $+125$ °C



- PCA9701 offered in SO24, TSSOP24 and HWQFN24 packages
- PCA9702 offered in TSSOP16 package

3. Applications

- Body control modules
- Switch monitoring
- Industrial equipment
- Cellular telephones
- Emergency lighting
- SBC wake pin extension

4. Ordering information

Table 1. Ordering information

Type number	Topside marking	Package		Version
		Name	Description	
PCA9701D	PCA9701D	SO24	plastic small outline package; 24 leads; body width 7.5 mm	SOT137-1
PCA9701HF	9701	HWQFN24	plastic thermal enhanced very very thin quad flat package; no leads; 24 terminals; body 4 × 4 × 0.75 mm	SOT994-1
PCA9701PW	PCA9701PW	TSSOP24	plastic thin shrink small outline package; 24 leads; body width 4.4 mm	SOT355-1
PCA9702PW	PCA9702	TSSOP16	plastic thin shrink small outline package; 16 leads; body width 4.4 mm	SOT403-1

4.1 Ordering options

Table 2. Ordering options

Type number	Orderable part number	Package	Packing method	Minimum order quantity	Temperature range
PCA9701D	PCA9701D,118	SO24	Reel 13" Q1/T1 *standard mark SMD	1000	T _{amb} = -40 °C to +125 °C
PCA9701HF	PCA9701HF,118	HWQFN24	Reel 13" Q1/T1 *standard mark SMD	6000	T _{amb} = -40 °C to +125 °C
PCA9701PW	PCA9701PW,118	TSSOP24	Reel 13" Q1/T1 *standard mark SMD	2500	T _{amb} = -40 °C to +125 °C
PCA9702PW	PCA9702PW,118	TSSOP16	Reel 13" Q1/T1 *standard mark SMD	2500	T _{amb} = -40 °C to +125 °C

5. Block diagram

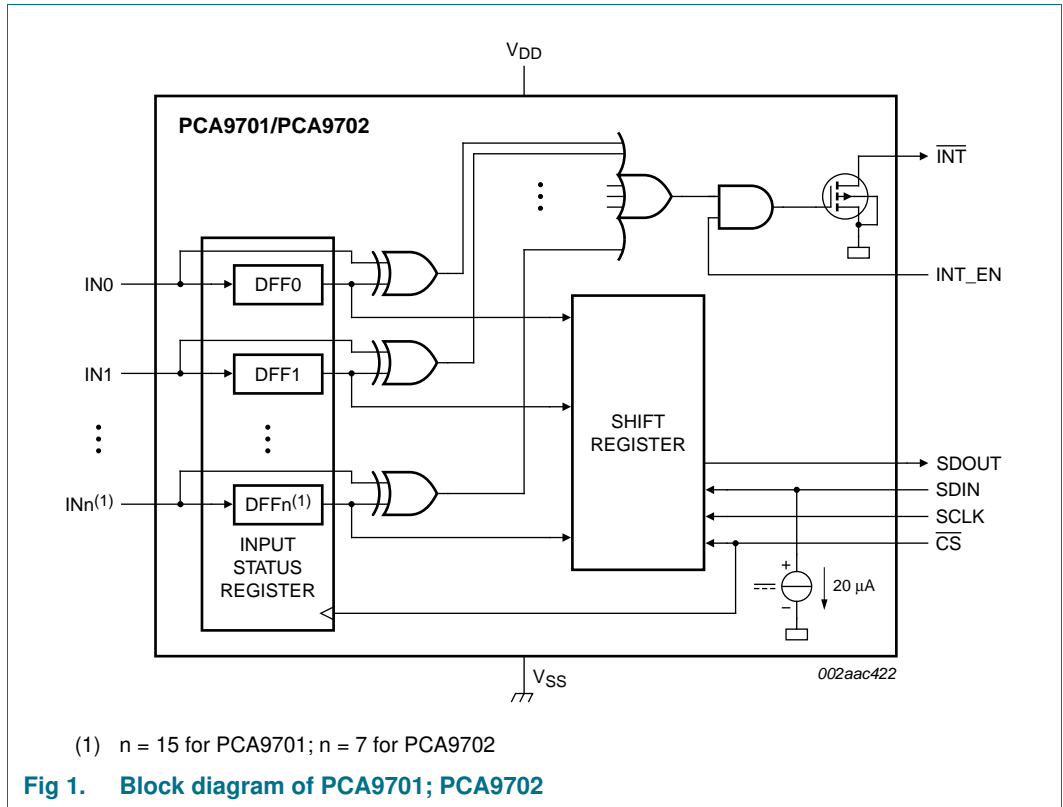

6. Pinning information

6.1 Pinning

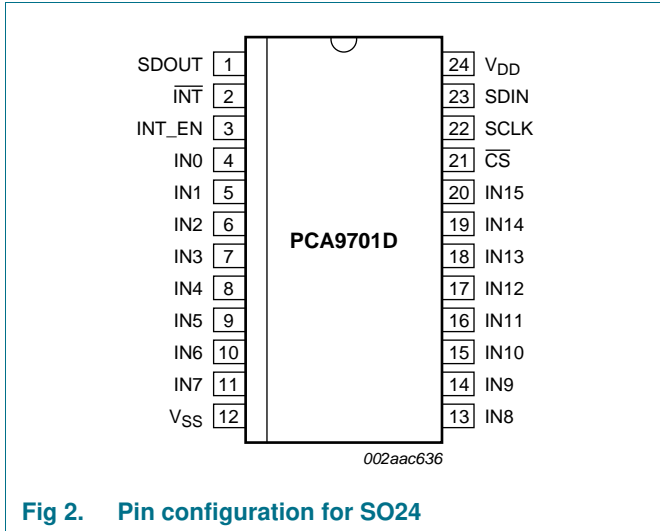

Fig 2. Pin configuration for SO24

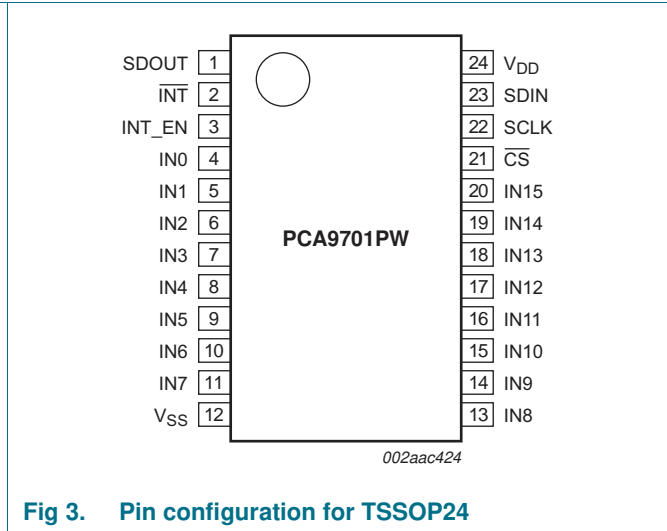

Fig 3. Pin configuration for TSSOP24

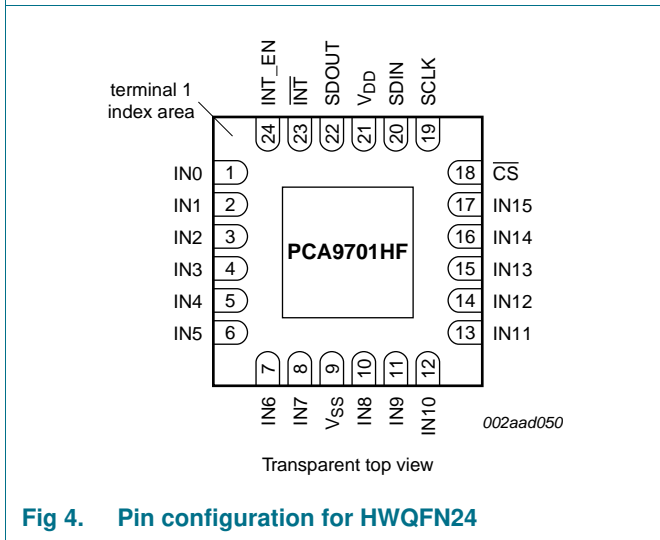

Fig 4. Pin configuration for HWQFN24

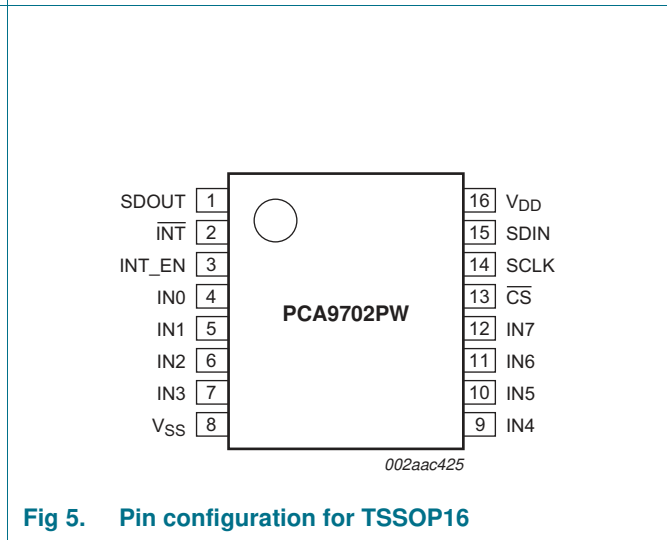

Fig 5. Pin configuration for TSSOP16

6.2 Pin description

Table 3. Pin description

Symbol	Pin			Type	Description
	SO24, TSSOP24	HWQFN24	TSSOP16		
SDOUT	1	22	1	output	3-state serial data output; normally high-impedance
$\overline{\text{INT}}$	2	23	2	output	open-drain interrupt output (active LOW)
INT_EN	3	24	3	input	interrupt output enable 1 = interrupt is enabled 0 = interrupt is disabled and high-impedance
IN0	4	1	4	input	input port 0
IN1	5	2	5	input	input port 1
IN2	6	3	6	input	input port 2
IN3	7	4	7	input	input port 3
IN4	8	5	9	input	input port 4
IN5	9	6	10	input	input port 5
IN6	10	7	11	input	input port 6
IN7	11	8	12	input	input port 7
V _{SS}	12	9 ^[1]	8	ground	ground supply
IN8	13	10	-	input	input port 8
IN9	14	11	-	input	input port 9
IN10	15	12	-	input	input port 10
IN11	16	13	-	input	input port 11
IN12	17	14	-	input	input port 12
IN13	18	15	-	input	input port 13
IN14	19	16	-	input	input port 14
IN15	20	17	-	input	input port 15
$\overline{\text{CS}}$	21	18	13	input	chip select (active LOW)
SCLK	22	19	14	input	serial input clock
SDIN	23	20	15	input	serial data input (20 μ A pull-down)
V _{DD}	24	21	16	supply	supply voltage

- [1] HWQFN24 package die supply ground is connected to both V_{SS} pin and exposed center pad. V_{SS} pin must be connected to supply ground for proper device operation. For enhanced thermal, electrical, and board level performance, the exposed pad needs to be soldered to the board using a corresponding thermal pad on the board and for proper heat conduction through the board, thermal vias need to be incorporated in the PCB in the thermal pad region.

7. Functional description

PCA9701 is a 16-bit General Purpose Input (GPI) with an open-drain interrupt output designed to monitor switch status. By putting an external 100 k Ω series resistor at the input port, the device allows the input to tolerate momentary double 12 V battery, reverse battery, 27 V jump start or 40 V load dump conditions. The interrupt output is asserted when an input port status changes. The open-drain interrupt output is enabled when $\overline{\text{INT_EN}}$ is HIGH and disabled when $\overline{\text{INT_EN}}$ is LOW. The input port status is accessed via the 4-wire SPI interface. The PCA9702 is the 8-bit version of the PCA9701.

Multiple PCA9701 or PCA9702 devices can be serially connected for monitoring a large number of switches by connecting the $\overline{\text{SDOUT}}$ of one device to the $\overline{\text{SDIN}}$ of the next device. $\overline{\text{SCLK}}$ and $\overline{\text{CS}}$ must be common among all devices and interrupt outputs may be tied together. No external logic is necessary because all the devices' interrupt outputs are open-drain that function as 'wired-AND' and can simply be connected together to a single pull-up resistor.

7.1 SPI bus operation

The PCA9701 or PCA9702 interfaces with the controller via the 4-wire SPI bus that is comprised of the following signals: chip select ($\overline{\text{CS}}$), serial clock (SCLK), serial data in ($\overline{\text{SDIN}}$), and serial data out ($\overline{\text{SDOUT}}$). To access the device, the controller asserts $\overline{\text{CS}}$ LOW, then sends SCLK and $\overline{\text{SDIN}}$. When reading/writing is complete, the controller de-asserts $\overline{\text{CS}}$. See [Figure 6](#) for register access timing.

7.1.1 $\overline{\text{CS}}$ - chip select

The $\overline{\text{CS}}$ pin is the device chip select and is an active LOW input. The falling edge of $\overline{\text{CS}}$ captures the input port status in the input status register. If the interrupt output is asserted, the falling edge of $\overline{\text{CS}}$ will clear the interrupt. When $\overline{\text{CS}}$ is LOW, the SPI interface is active. When $\overline{\text{CS}}$ is HIGH, the SPI interface is disabled.

7.1.2 SCLK - serial clock input

SCLK is the serial clock input to the device. It should be LOW and remain LOW during the falling and rising edge of $\overline{\text{CS}}$. When $\overline{\text{CS}}$ is LOW, the first rising edge of SCLK parallel loads the shift register from the input. The subsequent rising edges on SCLK serially shifts data out from the shift register. The falling edge of SCLK samples the data on $\overline{\text{SDIN}}$.

7.1.3 $\overline{\text{SDIN}}$ - serial data input

$\overline{\text{SDIN}}$ is the serial data input port. The data is sampled into the shift register on the falling edge of SCLK. $\overline{\text{SDIN}}$ is only active when $\overline{\text{CS}}$ is LOW. This input has a 20 μA pull-down current source.

7.1.4 $\overline{\text{SDOUT}}$ - serial data output

$\overline{\text{SDOUT}}$ is the serial data output signal. $\overline{\text{SDOUT}}$ is high-impedance when $\overline{\text{CS}}$ is HIGH and switches to low-impedance after $\overline{\text{CS}}$ goes LOW. When $\overline{\text{CS}}$ is LOW, after the first rising edge of SCLK the most significant bit in the shift register is presented on $\overline{\text{SDOUT}}$. Subsequent rising edges of SCLK shift the remaining data from the shift register onto $\overline{\text{SDOUT}}$.

7.1.5 Register access timing

Figure 6 shows the waveforms of the device operation. Initially \overline{CS} is HIGH and SCLK is LOW. On the falling edge of \overline{CS} , input port status, DATA[n:0] is captured into the input status register, and subsequently the first rising edge of SCLK parallel loads the shift register. The falling edge of SCLK samples the data on the SDIN. The MSB from the shift register is valid and available on the SDOUT after the first rising edge of SCLK.

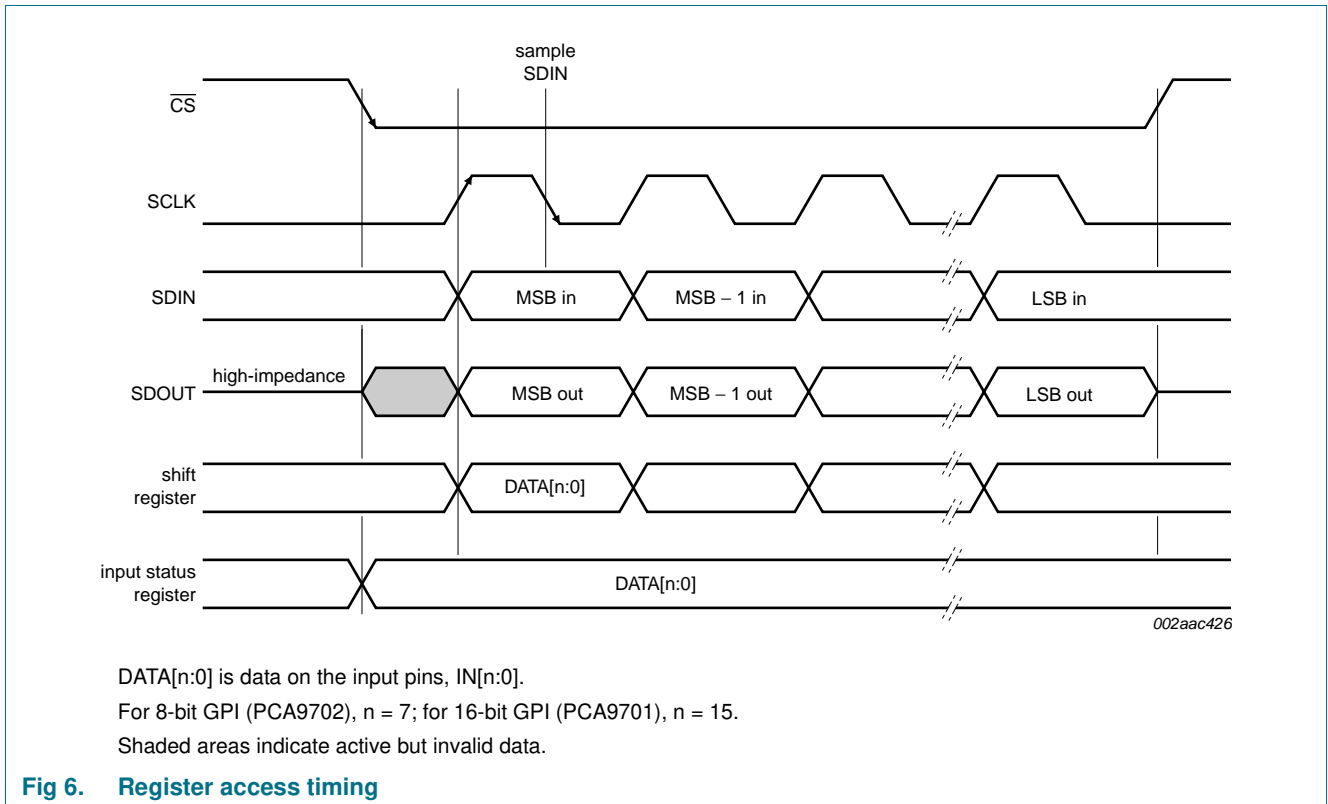

7.2 Interrupt output

\overline{INT} is the open-drain interrupt output and is active LOW. A pull-up resistor of approximately 10 k Ω is recommended. The interrupt output is asserted when the input status is changed, and is cleared on the falling edge of \overline{CS} or when the input port status matches the input status register. When there are multiple devices, the \overline{INT} outputs may be tied together to a single pull-up.

Table 4 illustrates the state of the interrupt output versus the state of the input port and input status register. The interrupt output is asserted when the input port and input status register differ.

Table 4. Interrupt output function truth table

H = HIGH; L = LOW; X = don't care

INT_EN	Input port status	Input status register ^[1]	$\overline{\text{INT}}$ output ^[2]
H	L	L	H
H	L	H	L
H	H	L	L
H	H	H	H
L	X	X	H

[1] Input status register is the value or content of the D flip-flops.

[2] Logic states shown for $\overline{\text{INT}}$ pin assumes 10 kΩ pull-up resistor.

7.3 General Purpose Inputs

The General Purpose Inputs (GPI) are designed to behave like a typical input in the 0 V to 5.5 V range, but are also designed to have low leakage currents at elevated voltages. The input structure allows for elevated voltages to be applied through a series resistor. The series resistor is required when the input voltage is above 5.5 V. The series resistor is required for two reasons: first, to prevent damage to the input avalanche diode, and second, to prevent the ESD protection circuitry from creating an excessive current flow. The ESD protection circuitry includes a latch-back style device, which provides excellent ESD protection during assembly or typical 5.5 V applications. The series resistor limits the current flowing into the part and provides additional ESD protection. The limited current prevents the ESD latch-back device from latching back to a low voltage, which would cause excessive current flow and damage the part.

The minimum required series resistance for applications with input voltages above 5.5 V is 100 kΩ. For applications requiring an applied voltage above 27 V, [Equation 1](#) is recommended to determine the series resistor. Failure to include the appropriate input series resistor may result in product failure and will void the warranty.

$$R_s = \frac{\text{voltage applied} - 17 \text{ V}}{I_I} \tag{1}$$

The series resistor should be placed physically as close as possible to the connected input to reduce the effective node capacitance. The input response time is effected by the RC time constant of the series resistor and the input node capacitance.

7.3.1 V_{IL} , V_{IH} and switching points

A minimum LOW threshold of 2.0 V is guaranteed for the logical switching points for the inputs. See [Figure 7](#) for details.

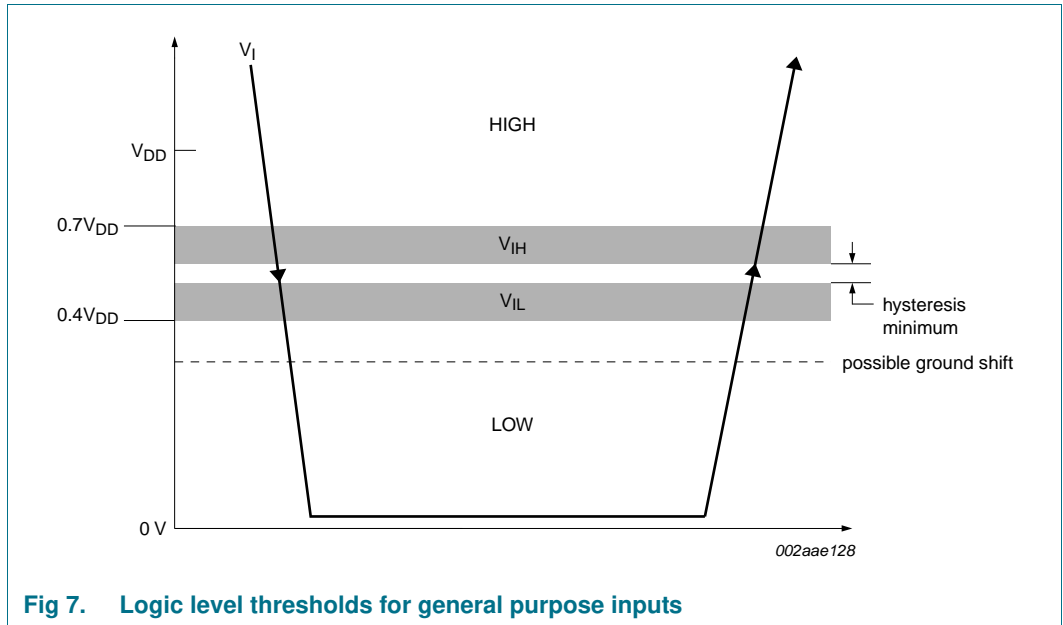

Fig 7. Logic level thresholds for general purpose inputs

The V_{IL} is specified as a maximum of $0.40 \times V_{DD}$ and is 2.0 V at 4.5 V V_{DD} . This means that if the user applies 2.0 V or less to the input (with $V_{DD} = 4.5$ V), or as the voltage passes this threshold, they will always see a LOW.

The V_{IH} is specified as a minimum of $0.7 \times V_{DD}$. This means that if the user applies 3.15 V or more to the input (with $V_{DD} = 4.5$ V), or as the voltage passes this threshold, they will always see a HIGH.

8. Application design-in information

8.1 General application

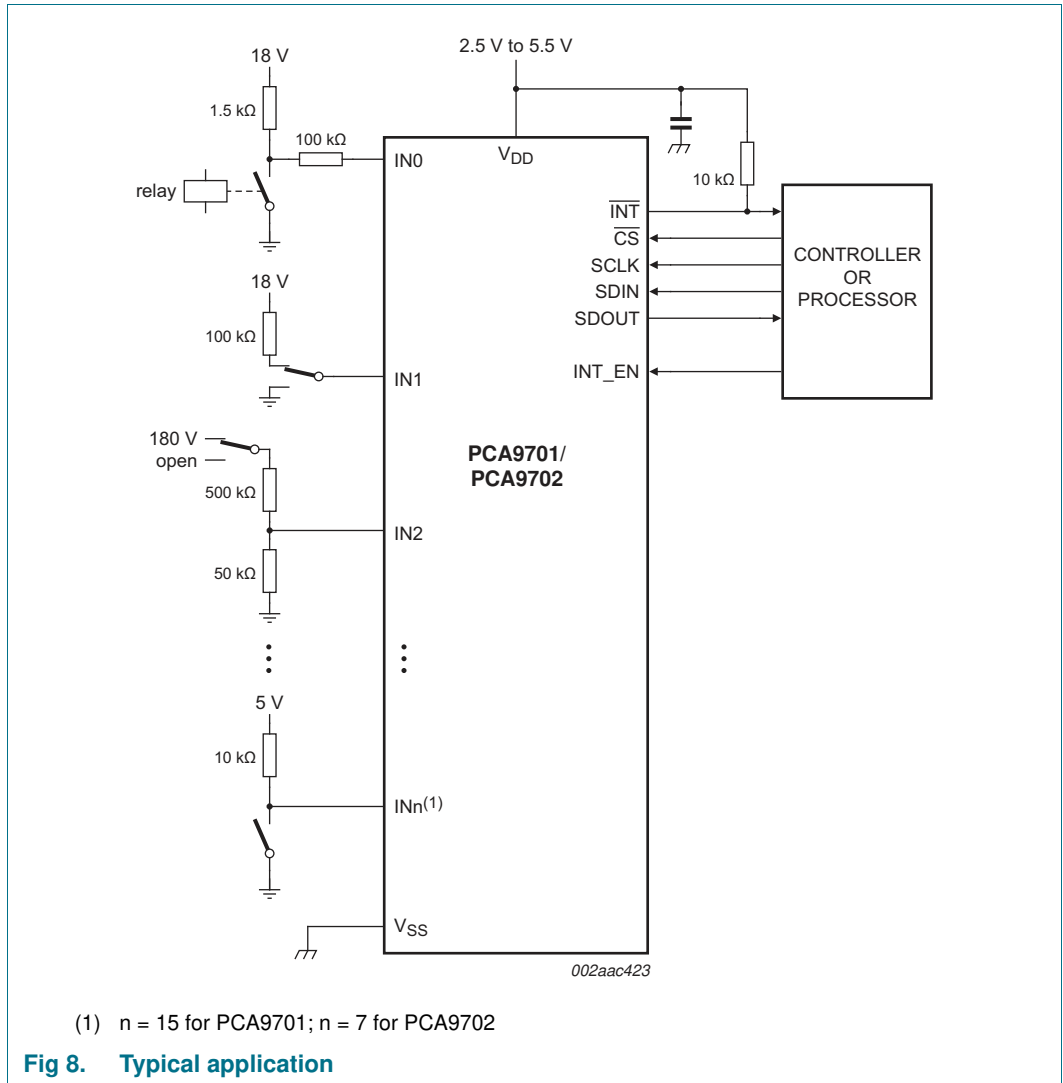

8.2 Automotive application

Supports:

- 12 V battery (8 V to 16 V)
- Double battery (16 V to 32 V)
- Reverse battery (−8 V to −16 V)
- Jump start (27 V for 60 seconds)
- Load dump (40 V)

8.2.1 SBC wake port extension with cyclic biasing

System Basis Chips (SBC) offer many functions needed for in-vehicle networking solutions. Some of the features built into SBC are:

- Transceivers (HS-CAN, LIN 2.0)
- Scalable voltage regulators
- Watchdog timers; wake-up function
- Fail-safe function

For more information on SBC, refer to

[http://www.nxp.com/index.html#/pip/pip=\[pfp=53482\]|pp=\[t=pfp,i=53482\]](http://www.nxp.com/index.html#/pip/pip=[pfp=53482]|pp=[t=pfp,i=53482]).

8.2.1.1 UJA106x with PCA9701, standby

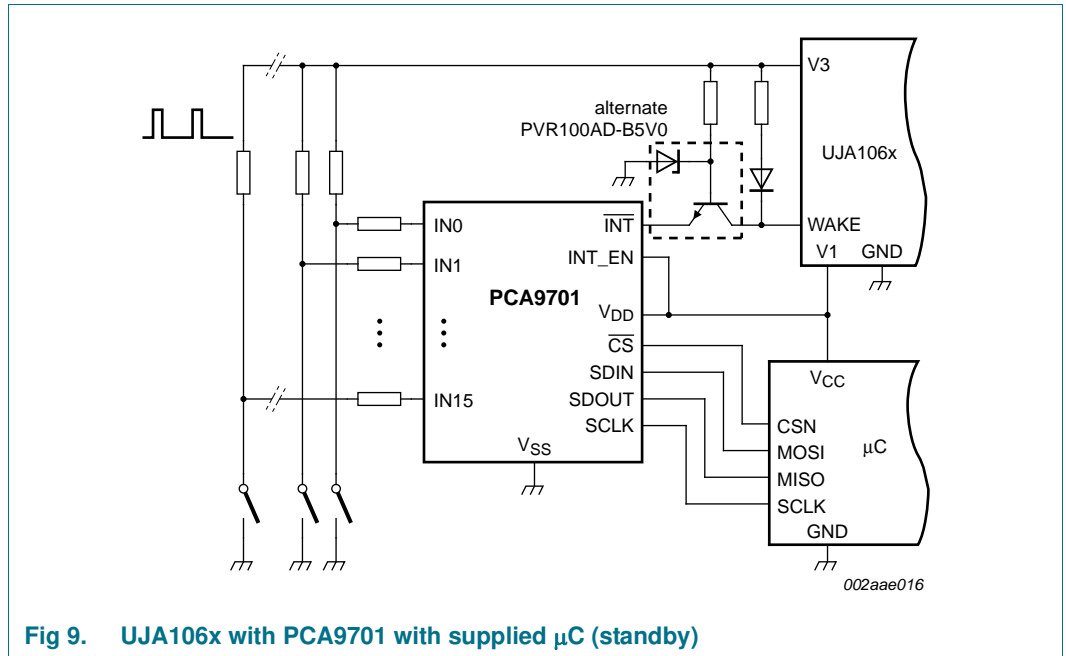

Fig 9. UJA106x with PCA9701 with supplied μC (standby)

- PCA970x fits to SBC UJA106x and UJA107xA family
- PCA970x can be powered by V1 of SBC
- Extends the SBC with 8/16 additional wake inputs
- μC can be set to stop-mode during standby to save ECU standby current. SBC with GPI periodically monitors the wake inputs
 - Cyclic bias via V3
 - Very low system current consumption even with clamped switches

8.2.1.2 UJA106x with PCA9701, sleep

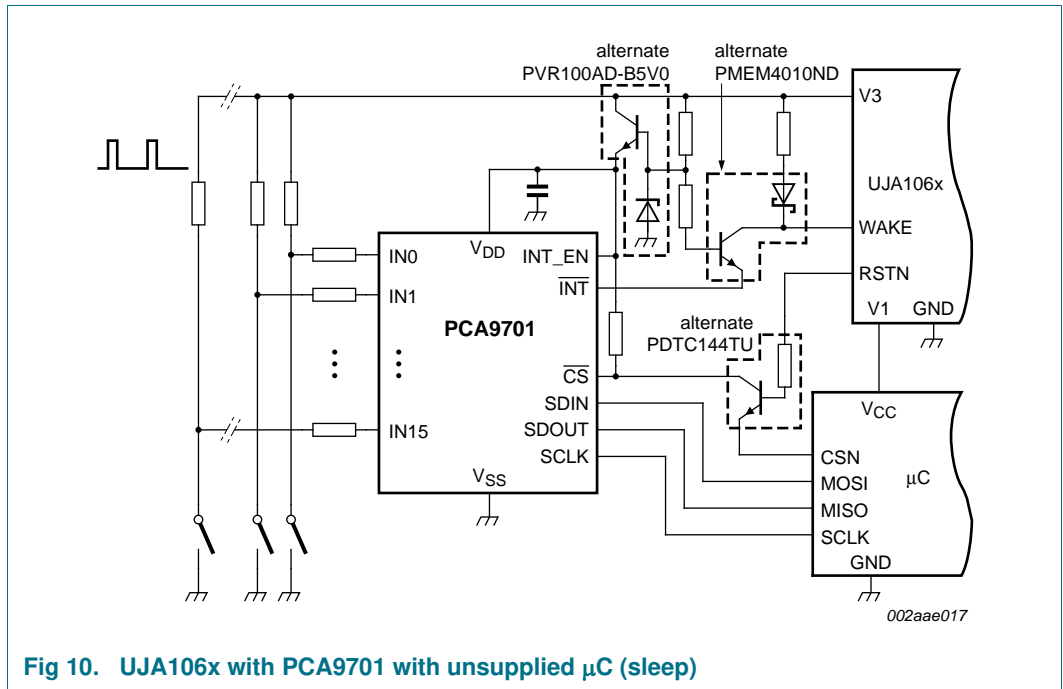

Fig 10. UJA106x with PCA9701 with unsupplied µC (sleep)

- Very low quiescent system current (50 µA) due to disabled µC and cyclically biasing of switches
- Wake-up upon change of switches or upon bus traffic (CAN and LIN)
- PCA970x supplied out of cyclically biased transistor regulator

8.2.1.3 UJA107xA with PCA9701, standby

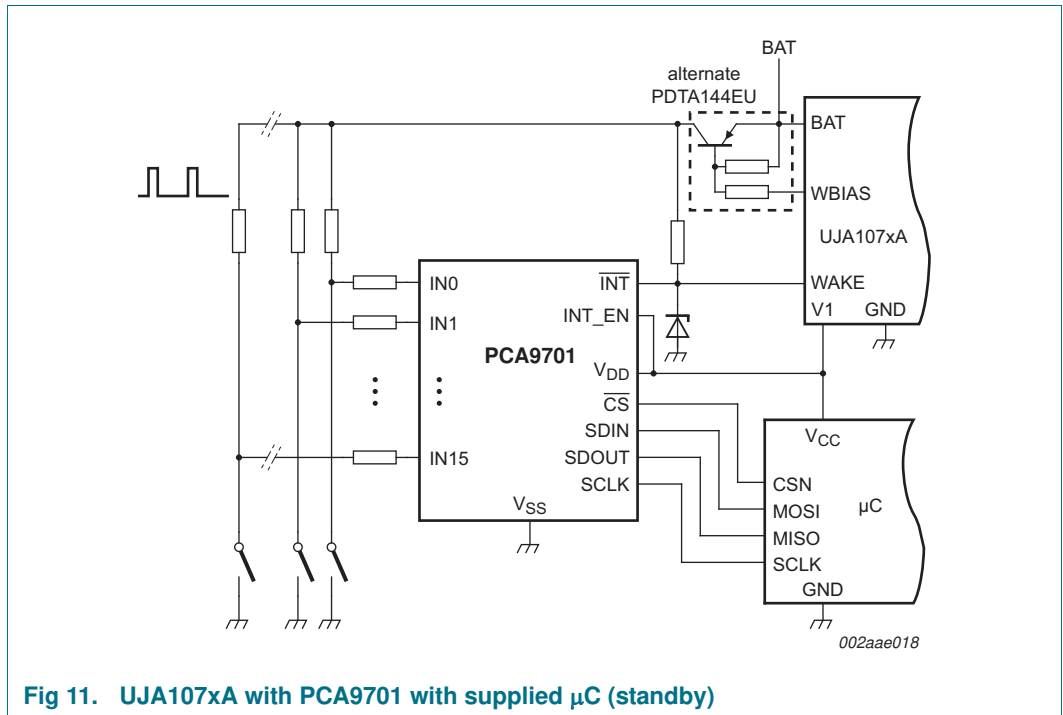

Fig 11. UJA107xA with PCA9701 with supplied μ C (standby)

- UJA107xA SBC provides WBIAS pin for cyclic biasing of the inputs
- Compatible with UJA107xA based ASSPs

8.2.2 Application examples including switches to battery

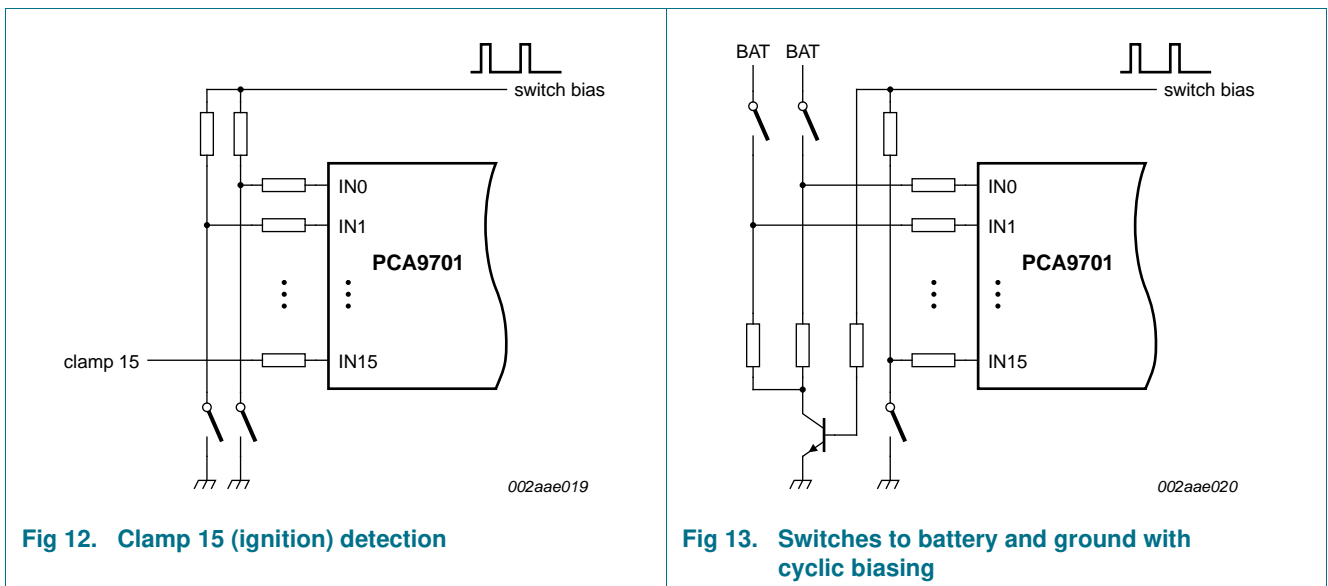

Fig 12. Clamp 15 (ignition) detection

Fig 13. Switches to battery and ground with cyclic biasing

9. Limiting values

Table 5. Limiting values

In accordance with the Absolute Maximum Rating System (IEC 60134).

$T_{amb} = -40\text{ °C}$ to $+125\text{ °C}$, unless otherwise specified.

Symbol	Parameter	Conditions		Min	Max	Unit
V_{DD}	supply voltage			-0.5	+6.0	V
I_I	input current	IN[n:0] pins with series resistor and $V_I > 5.5\text{ V}$,	[1][2]	-	350	μA
V_I	input voltage	GPI pins IN[n:0]; no series resistor	[1][2]	-0.5	+6	V
		SPI pins		-0.5	+6	V
T_{stg}	storage temperature			-65	+150	$^{\circ}\text{C}$
$T_{j(max)}$	maximum junction temperature	operating		-	125	$^{\circ}\text{C}$

[1] With GPI external series resistors, the inputs support double battery, reverse battery and load dump conditions. During double battery or load dump the input pin will drain slightly higher leakage current until the input drops to 18 V. For more detail of leakage current specification, please refer to [Table 6 "Static characteristics"](#). See [Section 7.3](#) for series resistor requirements.

[2] n = 15 for PCA9701; n = 7 for PCA9702.

10. Static characteristics

Table 6. Static characteristics
 $V_{DD} = 2.5 \text{ V to } 5.5 \text{ V}; V_{SS} = 0 \text{ V}; T_{amb} = -40 \text{ }^{\circ}\text{C to } +125 \text{ }^{\circ}\text{C};$ unless otherwise specified.

Symbol	Parameter	Conditions	Min	Typ	Max	Unit
Supply						
V_{DD}	supply voltage		2.5	3.3	5.5	V
I_{DD}	supply current	$V_{DD} = 5.5 \text{ V};$ input = 5 V or 18 V; INT_EN = V_{DD}	-	1.0	2.5	μA
V_{POR}	power-on reset voltage ^[1]		-	1.8	2.2	V
General Purpose Inputs						
V_{IL}	LOW-level input voltage		^[2] -	-	$0.4V_{DD}$	V
V_{IH}	HIGH-level input voltage		$0.7V_{DD}$	-	-	V
I_I	input current	GPI recommended maximum current; $V_I > 5.5 \text{ V};$ with series resistor R_s	^[3] -	-	100	μA
I_{IH}	HIGH-level input current	each input; $V_I = V_{DD}$	-1	-	+1	μA
I_{LI}	input leakage current	$V_I = 17 \text{ V};$ 100 k Ω series resistor	-1	-	+1	μA
C_i	input capacitance	$V_I = V_{SS}$ or V_{DD}	-	2.0	5.0	pF
Interrupt output						
I_{OL}	LOW-level output current	$V_{DD} = 4.5 \text{ V}; V_{OL} = 0.4 \text{ V}$	6	-	-	mA
		$V_{DD} = 2.5 \text{ V}; V_{OL} = 0.4 \text{ V}$	3	-	-	mA
I_{OH}	HIGH-level output current	$V_{OH} = V_{DD}$	-1	-	+1	μA
C_o	output capacitance		-	2	5	pF
SPI and control						
V_{IL}	LOW-level input voltage		-	-	$0.3V_{DD}$	V
V_{IH}	HIGH-level input voltage		$0.7V_{DD}$	-	5.5	V
I_{IH}	HIGH-level input current	SDIN; $V_I = V_{DD} = 5.5 \text{ V}$	-	20	40	μA
I_{OL}	LOW-level output current	SDOUT; $V_{OL} = 0.4 \text{ V}$				
		$V_{DD} = 4.5 \text{ V}$	5	-	-	mA
		$V_{DD} = 2.5 \text{ V}$	3	-	-	mA
I_{OH}	HIGH-level output current	SDOUT; $V_{OH} = V_{DD} - 0.5 \text{ V}$				
		$V_{DD} = 4.5 \text{ V}$	-5	-11	-	mA
		$V_{DD} = 2.5 \text{ V}$	-3	-7	-	mA
C_i	input capacitance	$V_I = V_{SS}$ or V_{DD}	-	2	5	pF
C_o	output capacitance	SDOUT; $\overline{CS} = V_{DD}$	-	4	6	pF

[1] V_{DD} must be lowered to 0.2 V for at least 5 μs in order to reset device.

[2] Minimum V_{IL} is 2.0 V at $V_{DD} = 4.5 \text{ V}$.

[3] For GPI pin voltages $> 5.5 \text{ V}$, see [Section 7.3](#).

11. Dynamic characteristics

Table 7. Dynamic characteristics

$V_{DD} = 2.5\text{ V to }5.5\text{ V}$; $V_{SS} = 0\text{ V}$; $T_{amb} = -40\text{ }^{\circ}\text{C to }+125\text{ }^{\circ}\text{C}$; unless otherwise specified.

Symbol	Parameter	Conditions	Min	Typ	Max	Unit
f_{max}	maximum input clock frequency		-	-	5	MHz
t_r	rise time	SDOUT; 10 % to 90 % at 5 V	-	35	60	ns
t_f	fall time	SDOUT; 90 % to 10 % at 5 V	-	25	50	ns
t_{WH}	pulse width HIGH	SCLK	50	-	-	ns
t_{WL}	pulse width LOW	SCLK	50	-	-	ns
$t_{SPILEAD}$	SPI enable lead time	\overline{CS} falling edge to SCLK rising edge	50	-	-	ns
t_{SPILAG}	SPI enable lag time	SCLK falling edge to \overline{CS} rising edge	50	-	-	ns
$t_{su(SDIN)}$	SDIN set-up time	SDIN to SCLK falling edge	20	-	-	ns
$t_{h(SDIN)}$	SDIN hold time	from SCLK falling edge	30	-	-	ns
$t_{en(SDOUT)}$	SDOUT enable time	from \overline{CS} LOW to SDOUT low-impedance; Figure 17	-	-	55	ns
$t_{dis(SDOUT)}$	SDOUT disable time	from rising edge of \overline{CS} to SDOUT high-impedance; Figure 17	-	-	85	ns
$t_v(SDOUT)$	SDOUT valid time	from rising edge of SCLK; Figure 18	-	-	55	ns
$t_{su(SCLK)}$	SCLK set-up time	SCLK falling to \overline{CS} falling	50	-	-	ns
$t_{h(SCLK)}$	SCLK hold time	SCLK rising after \overline{CS} rising	50	-	-	ns
t_{POR}	power-on reset pulse time	time before \overline{CS} is active after $V_{DD} > V_{POR}$	-	-	250	ns
$t_{rel(int)}$	interrupt release time	after \overline{CS} going LOW; Figure 19	-	-	500	ns
$t_v(INT_N)$	valid time on pin \overline{INT}	after IN_n changes or INT_EN goes HIGH	-	-	100	ns

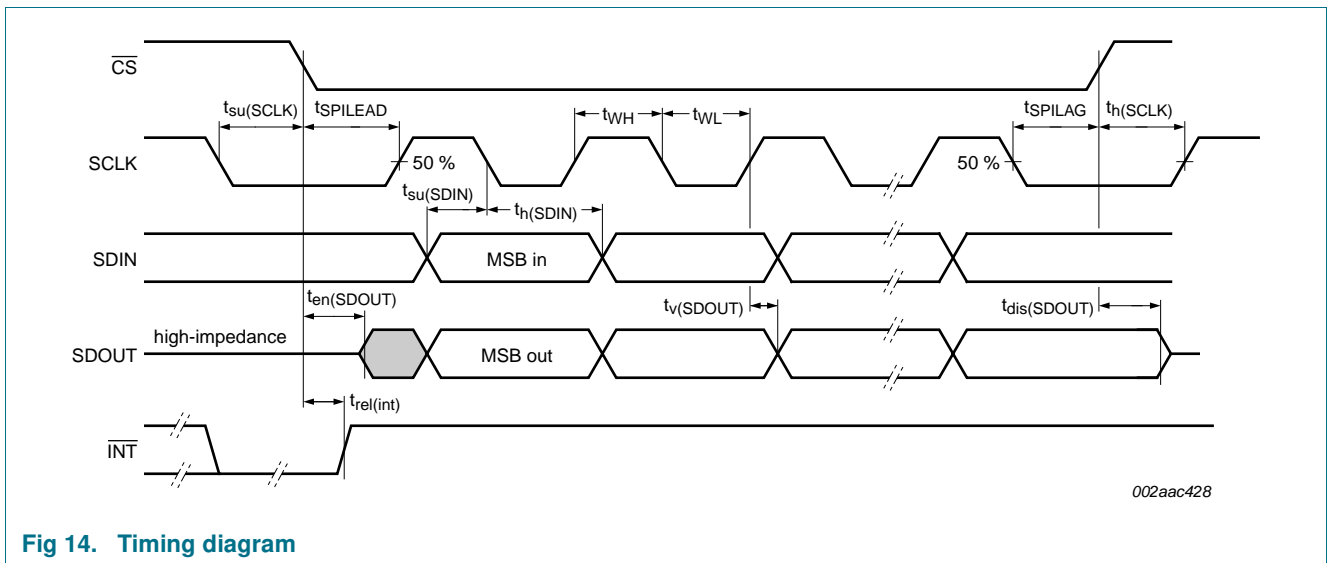

Fig 14. Timing diagram

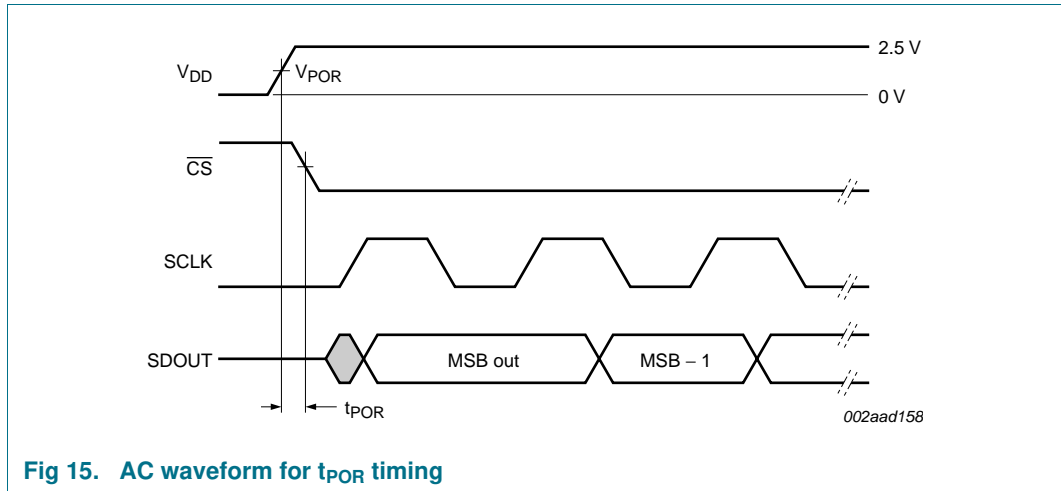

Fig 15. AC waveform for t_{POR} timing

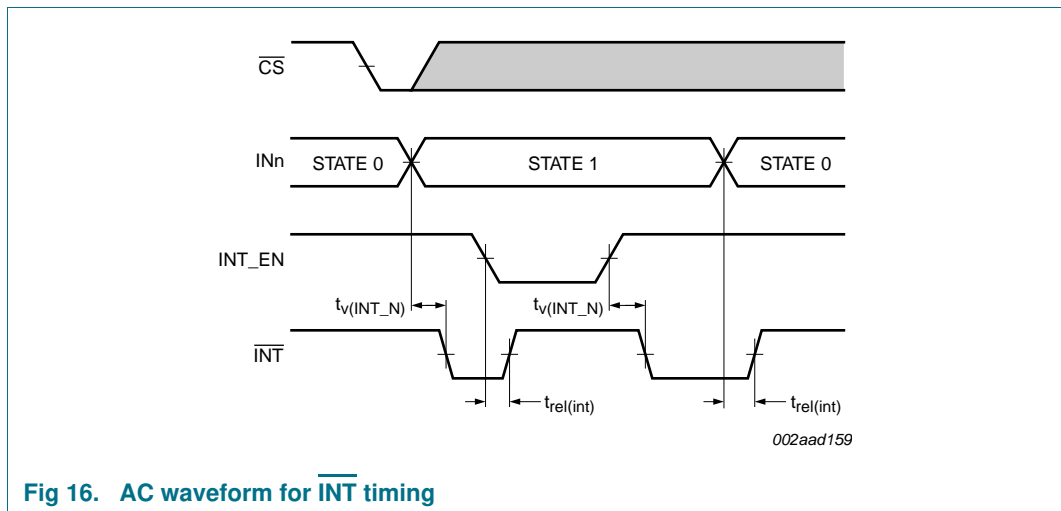

Fig 16. AC waveform for $\overline{\text{INT}}$ timing

12. Test information

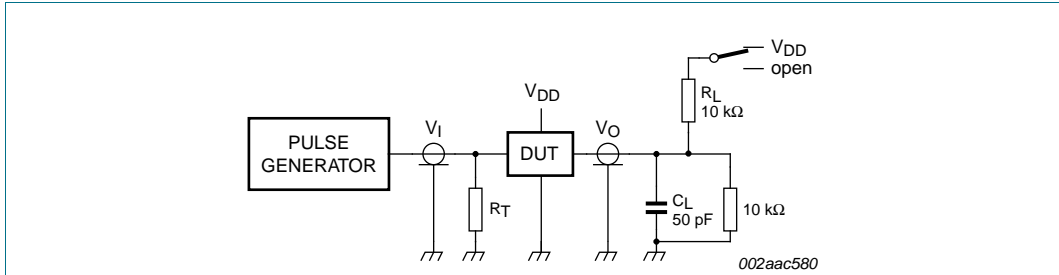

Fig 17. Test circuitry for enable/disable times, SDOUT ($t_{en(\text{SDOUT})}$ and $t_{dis(\text{SDOUT})}$)

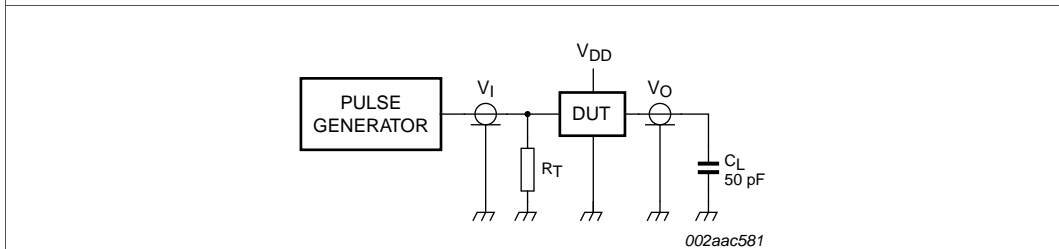

Fig 18. Test circuitry for switching times, SDOUT ($t_v(\text{SDOUT})$)

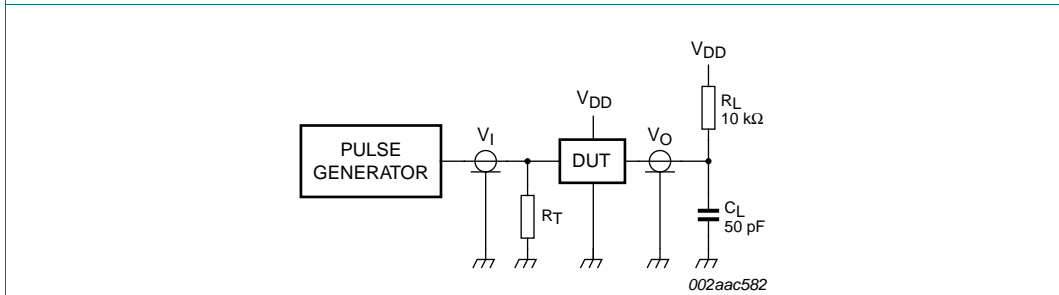

Fig 19. Test circuitry for switching times, $\overline{\text{INT}}$

R_L = load resistance.

C_L = load capacitance includes jig and probe capacitance.

R_T = termination resistance should be equal to the output impedance Z_o of the pulse generators.

13. Package outline

SO24: plastic small outline package; 24 leads; body width 7.5 mm

SOT137-1

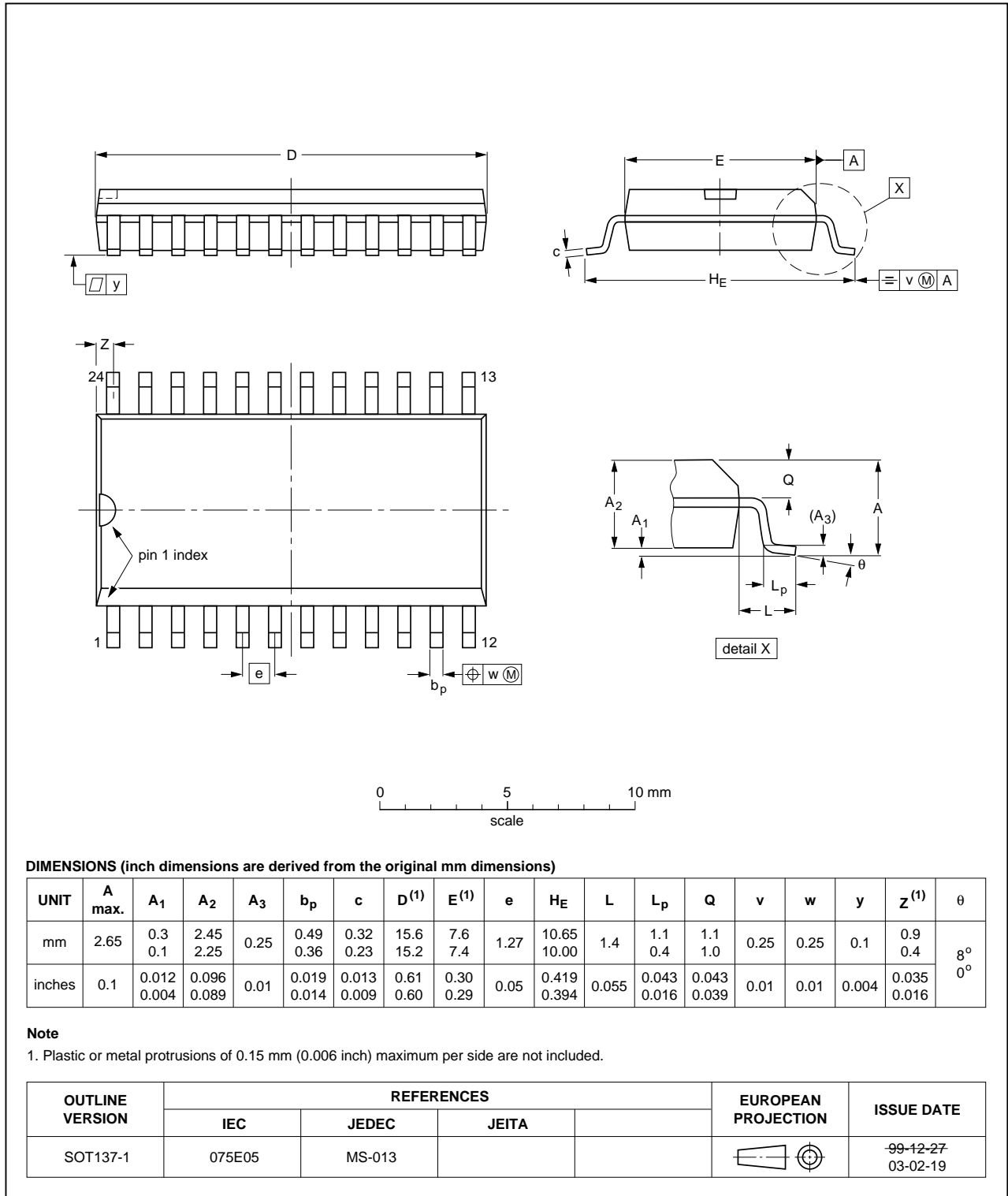

Fig 20. Package outline SOT137-1 (SO24)

TSSOP24: plastic thin shrink small outline package; 24 leads; body width 4.4 mm

SOT355-1

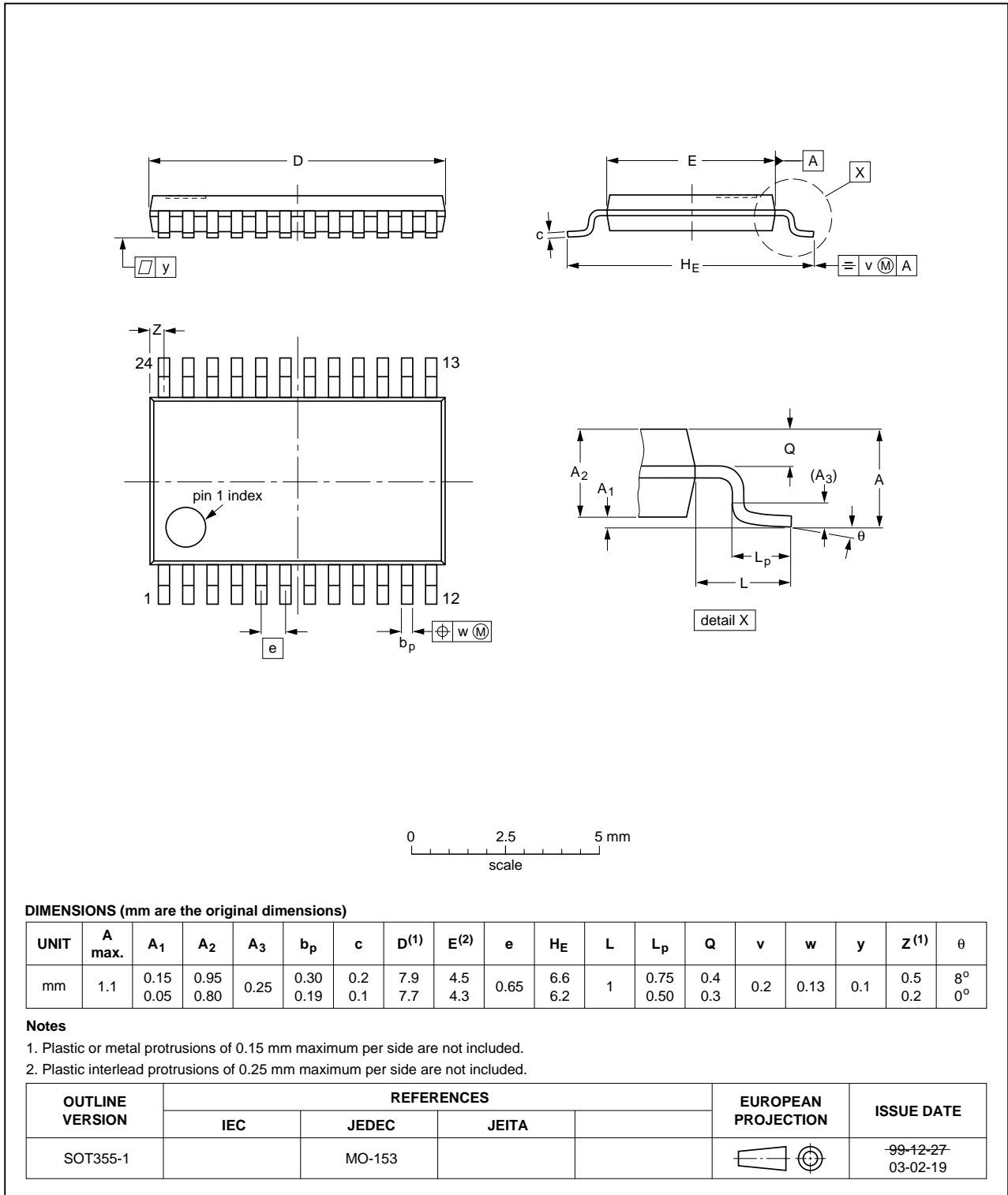

Fig 21. Package outline SOT355-1 (TSSOP24)

TSSOP16: plastic thin shrink small outline package; 16 leads; body width 4.4 mm

SOT403-1

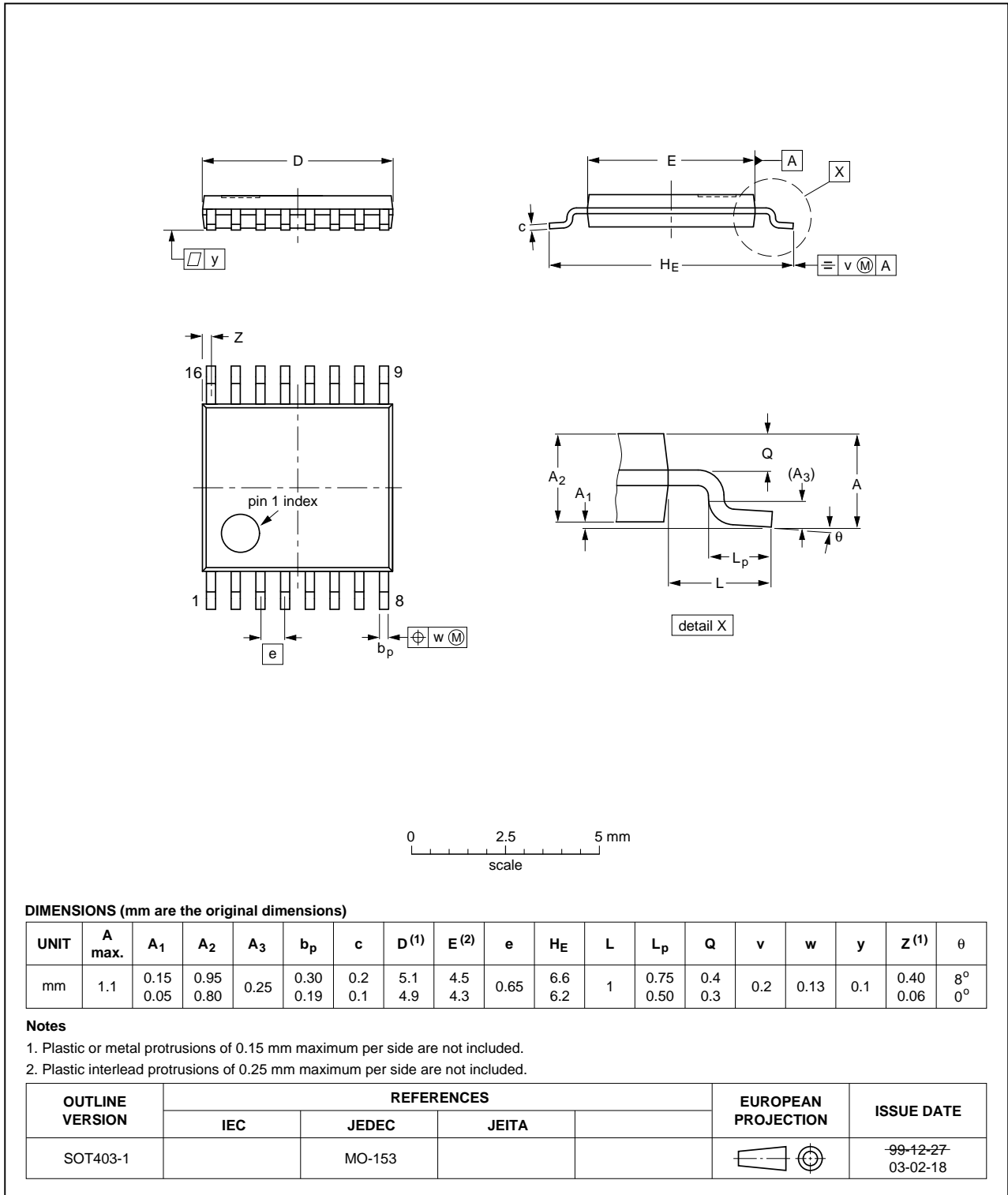
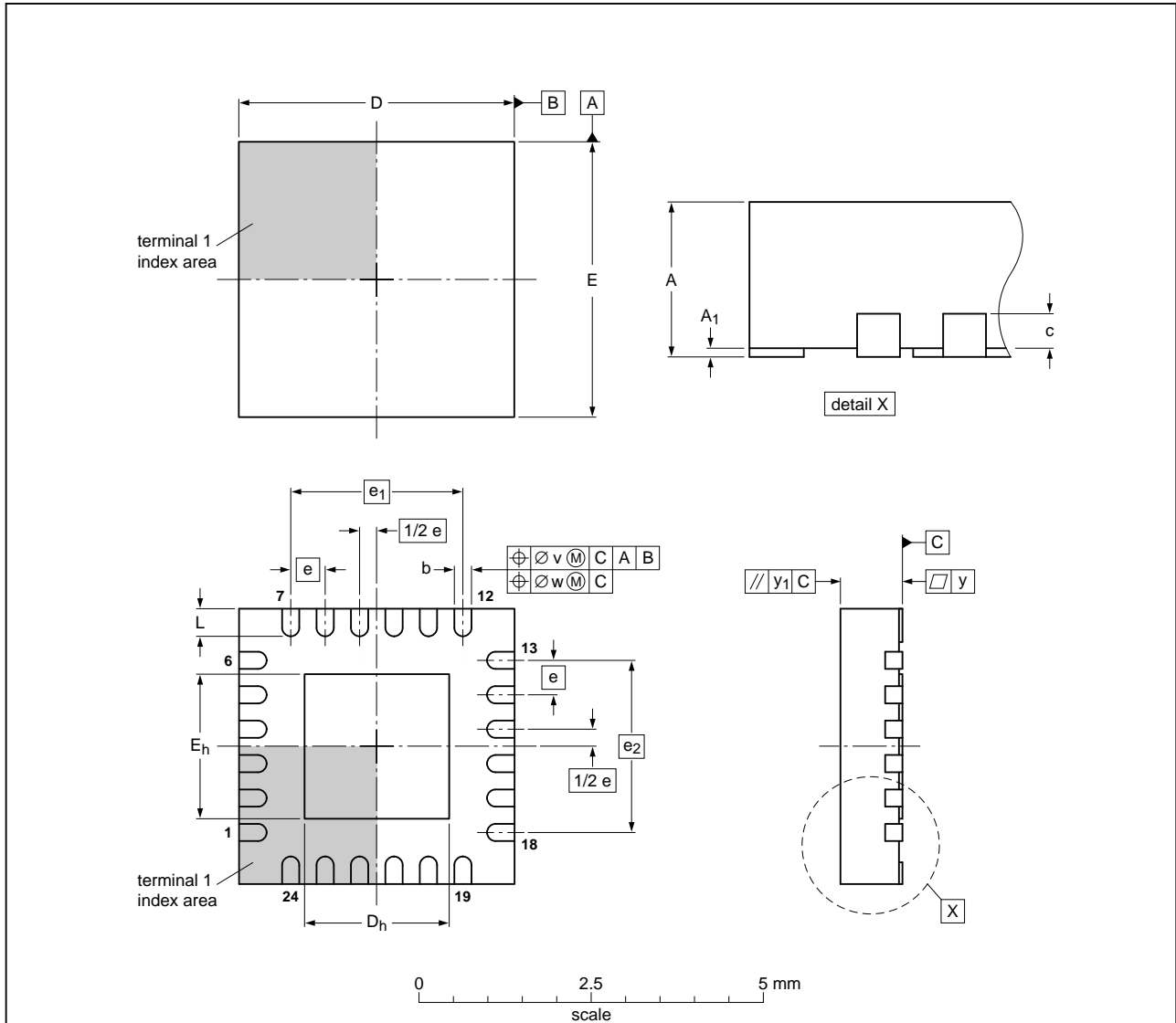

Fig 22. Package outline SOT403-1 (TSSOP16)

HWQFN24: plastic thermal enhanced very very thin quad flat package; no leads;
24 terminals; body 4 x 4 x 0.75 mm

SOT994-1



DIMENSIONS (mm are the original dimensions)

UNIT	A ⁽¹⁾ max	A ₁	b	c	D ⁽¹⁾	D _h	E ⁽¹⁾	E _h	e	e ₁	e ₂	L	v	w	y	y ₁
mm	0.8	0.05 0.00	0.30 0.18	0.2	4.1 3.9	2.25 1.95	4.1 3.9	2.25 1.95	0.5	2.5	2.5	0.5 0.3	0.1	0.05	0.05	0.1

Note
1. Plastic or metal protrusions of 0.075 mm maximum per side are not included.

OUTLINE VERSION	REFERENCES				EUROPEAN PROJECTION	ISSUE DATE
	IEC	JEDEC	JEITA			
SOT994-1	---	MO-220	---			07-02-07 07-03-03

Fig 23. Package outline SOT994-1 (HWQFN24)

14. Soldering of SMD packages

This text provides a very brief insight into a complex technology. A more in-depth account of soldering ICs can be found in Application Note *AN10365 "Surface mount reflow soldering description"*.

14.1 Introduction to soldering

Soldering is one of the most common methods through which packages are attached to Printed Circuit Boards (PCBs), to form electrical circuits. The soldered joint provides both the mechanical and the electrical connection. There is no single soldering method that is ideal for all IC packages. Wave soldering is often preferred when through-hole and Surface Mount Devices (SMDs) are mixed on one printed wiring board; however, it is not suitable for fine pitch SMDs. Reflow soldering is ideal for the small pitches and high densities that come with increased miniaturization.

14.2 Wave and reflow soldering

Wave soldering is a joining technology in which the joints are made by solder coming from a standing wave of liquid solder. The wave soldering process is suitable for the following:

- Through-hole components
- Leaded or leadless SMDs, which are glued to the surface of the printed circuit board

Not all SMDs can be wave soldered. Packages with solder balls, and some leadless packages which have solder lands underneath the body, cannot be wave soldered. Also, leaded SMDs with leads having a pitch smaller than ~0.6 mm cannot be wave soldered, due to an increased probability of bridging.

The reflow soldering process involves applying solder paste to a board, followed by component placement and exposure to a temperature profile. Leaded packages, packages with solder balls, and leadless packages are all reflow solderable.

Key characteristics in both wave and reflow soldering are:

- Board specifications, including the board finish, solder masks and vias
- Package footprints, including solder thieves and orientation
- The moisture sensitivity level of the packages
- Package placement
- Inspection and repair
- Lead-free soldering versus SnPb soldering

14.3 Wave soldering

Key characteristics in wave soldering are:

- Process issues, such as application of adhesive and flux, clinching of leads, board transport, the solder wave parameters, and the time during which components are exposed to the wave
- Solder bath specifications, including temperature and impurities

14.4 Reflow soldering

Key characteristics in reflow soldering are:

- Lead-free versus SnPb soldering; note that a lead-free reflow process usually leads to higher minimum peak temperatures (see [Figure 24](#)) than a SnPb process, thus reducing the process window
- Solder paste printing issues including smearing, release, and adjusting the process window for a mix of large and small components on one board
- Reflow temperature profile; this profile includes preheat, reflow (in which the board is heated to the peak temperature) and cooling down. It is imperative that the peak temperature is high enough for the solder to make reliable solder joints (a solder paste characteristic). In addition, the peak temperature must be low enough that the packages and/or boards are not damaged. The peak temperature of the package depends on package thickness and volume and is classified in accordance with [Table 8](#) and [9](#)

Table 8. SnPb eutectic process (from J-STD-020D)

Package thickness (mm)	Package reflow temperature (°C)	
	Volume (mm ³)	
	< 350	≥ 350
< 2.5	235	220
≥ 2.5	220	220

Table 9. Lead-free process (from J-STD-020D)

Package thickness (mm)	Package reflow temperature (°C)		
	Volume (mm ³)		
	< 350	350 to 2000	> 2000
< 1.6	260	260	260
1.6 to 2.5	260	250	245
> 2.5	250	245	245

Moisture sensitivity precautions, as indicated on the packing, must be respected at all times.

Studies have shown that small packages reach higher temperatures during reflow soldering, see [Figure 24](#).

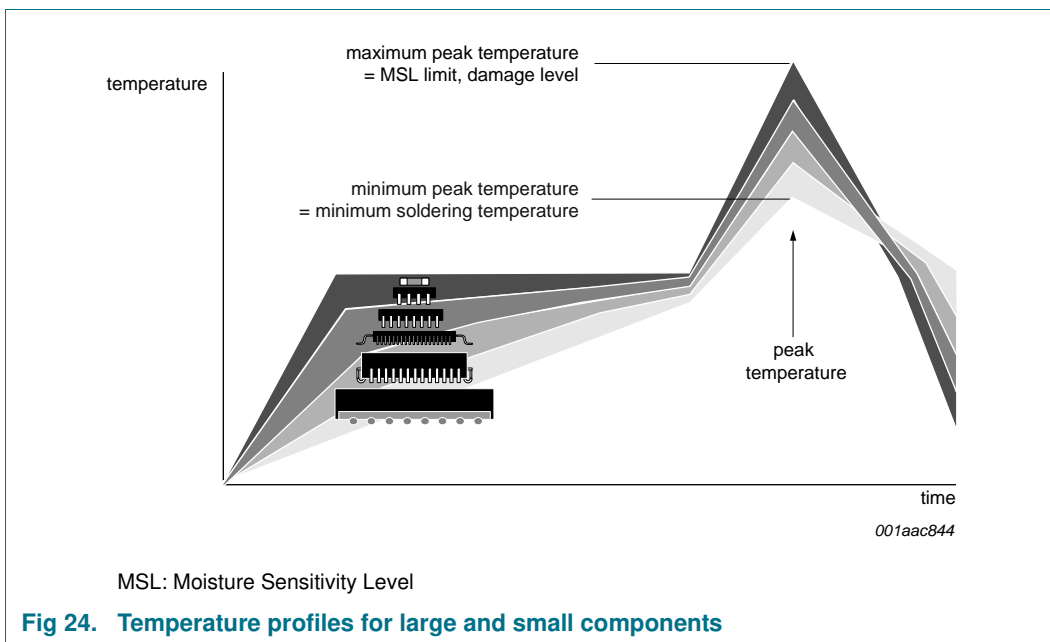

For further information on temperature profiles, refer to Application Note AN10365 “Surface mount reflow soldering description”.

15. Abbreviations

Table 10. Abbreviations

Acronym	Description
ASSP	Application Specific Standard Product
CAN	Controller Area Network
CDM	Charged-Device Model
DUT	Device Under Test
ECU	Electronic Control Unit
ESD	ElectroStatic Discharge
GPI	General Purpose Input
HBM	Human Body Model
HS-CAN	High-Speed Controller Area Network
LIN	Local Interconnect Network
LSB	Least Significant Bit
MM	Machine Model
MSB	Most Significant Bit
PCB	Printed-Circuit Board
PPAP	Production Part Approval Process
RC	Resistor-Capacitor network
SBC	System Basis Chip
SPI	Serial Peripheral Interface
μC	microcontroller

16. Revision history

Table 11. Revision history

Document ID	Release date	Data sheet status	Change notice	Supersedes
PCA9701_PCA9702 v.7	20140926	Product data sheet	-	PCA9701_PCA9702 v.6
Modifications:	<ul style="list-style-type: none"> • Section 1 “General description”, Section 2 “Features and benefits”: deleted references to “AEC-Q100” • Table 1 “Ordering information”: <ul style="list-style-type: none"> – removed type number PCA9701PW/Q900 (and associated table note [1]) • Figure 3 “Pin configuration for TSSOP24” deleted “PCA9701PW/Q900” • Added Table 2 “Ordering options” 			
PCA9701_PCA9702 v.6	20111214	Product data sheet	-	PCA9701_PCA9702 v.5
PCA9701_PCA9702 v.5	20091111	Product data sheet	-	PCA9701_PCA9702 v.4
PCA9701_PCA9702 v.4	20090716	Product data sheet	-	PCA9701_PCA9702 v.3
PCA9701_PCA9702 v.3	20081203	Product data sheet	-	PCA9701_PCA9702 v.2
PCA9701_PCA9702 v.2	20070829	Product data sheet	-	PCA9701_PCA9702 v.1
PCA9701_PCA9702 v.1	20070323	Objective data sheet	-	-

17. Legal information

17.1 Data sheet status

Document status ^{[1][2]}	Product status ^[3]	Definition
Objective [short] data sheet	Development	This document contains data from the objective specification for product development.
Preliminary [short] data sheet	Qualification	This document contains data from the preliminary specification.
Product [short] data sheet	Production	This document contains the product specification.

[1] Please consult the most recently issued document before initiating or completing a design.

[2] The term 'short data sheet' is explained in section "Definitions".

[3] The product status of device(s) described in this document may have changed since this document was published and may differ in case of multiple devices. The latest product status information is available on the Internet at URL <http://www.nxp.com>.

17.2 Definitions

Draft — The document is a draft version only. The content is still under internal review and subject to formal approval, which may result in modifications or additions. NXP Semiconductors does not give any representations or warranties as to the accuracy or completeness of information included herein and shall have no liability for the consequences of use of such information.

Short data sheet — A short data sheet is an extract from a full data sheet with the same product type number(s) and title. A short data sheet is intended for quick reference only and should not be relied upon to contain detailed and full information. For detailed and full information see the relevant full data sheet, which is available on request via the local NXP Semiconductors sales office. In case of any inconsistency or conflict with the short data sheet, the full data sheet shall prevail.

Product specification — The information and data provided in a Product data sheet shall define the specification of the product as agreed between NXP Semiconductors and its customer, unless NXP Semiconductors and customer have explicitly agreed otherwise in writing. In no event however, shall an agreement be valid in which the NXP Semiconductors product is deemed to offer functions and qualities beyond those described in the Product data sheet.

17.3 Disclaimers

Limited warranty and liability — Information in this document is believed to be accurate and reliable. However, NXP Semiconductors does not give any representations or warranties, expressed or implied, as to the accuracy or completeness of such information and shall have no liability for the consequences of use of such information. NXP Semiconductors takes no responsibility for the content in this document if provided by an information source outside of NXP Semiconductors.

In no event shall NXP Semiconductors be liable for any indirect, incidental, punitive, special or consequential damages (including - without limitation - lost profits, lost savings, business interruption, costs related to the removal or replacement of any products or rework charges) whether or not such damages are based on tort (including negligence), warranty, breach of contract or any other legal theory.

Notwithstanding any damages that customer might incur for any reason whatsoever, NXP Semiconductors' aggregate and cumulative liability towards customer for the products described herein shall be limited in accordance with the *Terms and conditions of commercial sale* of NXP Semiconductors.

Right to make changes — NXP Semiconductors reserves the right to make changes to information published in this document, including without limitation specifications and product descriptions, at any time and without notice. This document supersedes and replaces all information supplied prior to the publication hereof.

Suitability for use — NXP Semiconductors products are not designed, authorized or warranted to be suitable for use in life support, life-critical or safety-critical systems or equipment, nor in applications where failure or malfunction of an NXP Semiconductors product can reasonably be expected to result in personal injury, death or severe property or environmental damage. NXP Semiconductors and its suppliers accept no liability for inclusion and/or use of NXP Semiconductors products in such equipment or applications and therefore such inclusion and/or use is at the customer's own risk.

Applications — Applications that are described herein for any of these products are for illustrative purposes only. NXP Semiconductors makes no representation or warranty that such applications will be suitable for the specified use without further testing or modification.

Customers are responsible for the design and operation of their applications and products using NXP Semiconductors products, and NXP Semiconductors accepts no liability for any assistance with applications or customer product design. It is customer's sole responsibility to determine whether the NXP Semiconductors product is suitable and fit for the customer's applications and products planned, as well as for the planned application and use of customer's third party customer(s). Customers should provide appropriate design and operating safeguards to minimize the risks associated with their applications and products.

NXP Semiconductors does not accept any liability related to any default, damage, costs or problem which is based on any weakness or default in the customer's applications or products, or the application or use by customer's third party customer(s). Customer is responsible for doing all necessary testing for the customer's applications and products using NXP Semiconductors products in order to avoid a default of the applications and the products or of the application or use by customer's third party customer(s). NXP does not accept any liability in this respect.

Limiting values — Stress above one or more limiting values (as defined in the Absolute Maximum Ratings System of IEC 60134) will cause permanent damage to the device. Limiting values are stress ratings only and (proper) operation of the device at these or any other conditions above those given in the Recommended operating conditions section (if present) or the Characteristics sections of this document is not warranted. Constant or repeated exposure to limiting values will permanently and irreversibly affect the quality and reliability of the device.

Terms and conditions of commercial sale — NXP Semiconductors products are sold subject to the general terms and conditions of commercial sale, as published at <http://www.nxp.com/profile/terms>, unless otherwise agreed in a valid written individual agreement. In case an individual agreement is concluded only the terms and conditions of the respective agreement shall apply. NXP Semiconductors hereby expressly objects to applying the customer's general terms and conditions with regard to the purchase of NXP Semiconductors products by customer.

No offer to sell or license — Nothing in this document may be interpreted or construed as an offer to sell products that is open for acceptance or the grant, conveyance or implication of any license under any copyrights, patents or other industrial or intellectual property rights.

Export control — This document as well as the item(s) described herein may be subject to export control regulations. Export might require a prior authorization from competent authorities.

Non-automotive qualified products — Unless this data sheet expressly states that this specific NXP Semiconductors product is automotive qualified, the product is not suitable for automotive use. It is neither qualified nor tested in accordance with automotive testing or application requirements. NXP Semiconductors accepts no liability for inclusion and/or use of non-automotive qualified products in automotive equipment or applications.

In the event that customer uses the product for design-in and use in automotive applications to automotive specifications and standards, customer (a) shall use the product without NXP Semiconductors' warranty of the product for such automotive applications, use and specifications, and (b) whenever customer uses the product for automotive applications beyond

NXP Semiconductors' specifications such use shall be solely at customer's own risk, and (c) customer fully indemnifies NXP Semiconductors for any liability, damages or failed product claims resulting from customer design and use of the product for automotive applications beyond NXP Semiconductors' standard warranty and NXP Semiconductors' product specifications.

Translations — A non-English (translated) version of a document is for reference only. The English version shall prevail in case of any discrepancy between the translated and English versions.

17.4 Trademarks

Notice: All referenced brands, product names, service names and trademarks are the property of their respective owners.

18. Contact information

For more information, please visit: <http://www.nxp.com>

For sales office addresses, please send an email to: salesaddresses@nxp.com

19. Contents

1	General description	1	18	Contact information	28
2	Features and benefits	1	19	Contents	29
3	Applications	2			
4	Ordering information	2			
4.1	Ordering options	2			
5	Block diagram	3			
6	Pinning information	4			
6.1	Pinning	4			
6.2	Pin description	5			
7	Functional description	6			
7.1	SPI bus operation	6			
7.1.1	CS - chip select	6			
7.1.2	SCLK - serial clock input	6			
7.1.3	SDIN - serial data input	6			
7.1.4	SDOUT - serial data output	6			
7.1.5	Register access timing	7			
7.2	Interrupt output	7			
7.3	General Purpose Inputs	8			
7.3.1	V _{IL} , V _{IH} and switching points	9			
8	Application design-in information	10			
8.1	General application	10			
8.2	Automotive application	10			
8.2.1	SBC wake port extension with cyclic biasing ..	11			
8.2.1.1	UJA106x with PCA9701, standby	11			
8.2.1.2	UJA106x with PCA9701, sleep	12			
8.2.1.3	UJA107xA with PCA9701, standby	13			
8.2.2	Application examples including switches to battery	13			
9	Limiting values	14			
10	Static characteristics	15			
11	Dynamic characteristics	16			
12	Test information	18			
13	Package outline	19			
14	Soldering of SMD packages	23			
14.1	Introduction to soldering	23			
14.2	Wave and reflow soldering	23			
14.3	Wave soldering	23			
14.4	Reflow soldering	24			
15	Abbreviations	25			
16	Revision history	26			
17	Legal information	27			
17.1	Data sheet status	27			
17.2	Definitions	27			
17.3	Disclaimers	27			
17.4	Trademarks	28			

Please be aware that important notices concerning this document and the product(s) described herein, have been included in section 'Legal information'.

© NXP Semiconductors N.V. 2014.

All rights reserved.

For more information, please visit: <http://www.nxp.com>

For sales office addresses, please send an email to: salesaddresses@nxp.com

Date of release: 26 September 2014

Document identifier: PCA9701_PCA9702