

| COMPONENTS | | |
|------------|--------------------------|------|
| ITEM | PART NAME | Q'TY |
| 5 | SCREW, M3 x 10, SELF-TAP | 2 |
| 4 | CABLE TIE | 2 |
| 3 | CAP-2(BLACK) | 1 |
| 2 | CAP-1(WHITE) | 1 |
| 1 | HOUSING ASSEMBLY | 1 |

| DATE | REV | ECN | APP'D. BY |
|----------|-----|-------|-----------|
| 10/15/20 | A0 | - | ADB |
| 11/04/20 | A1 | 11655 | JE |

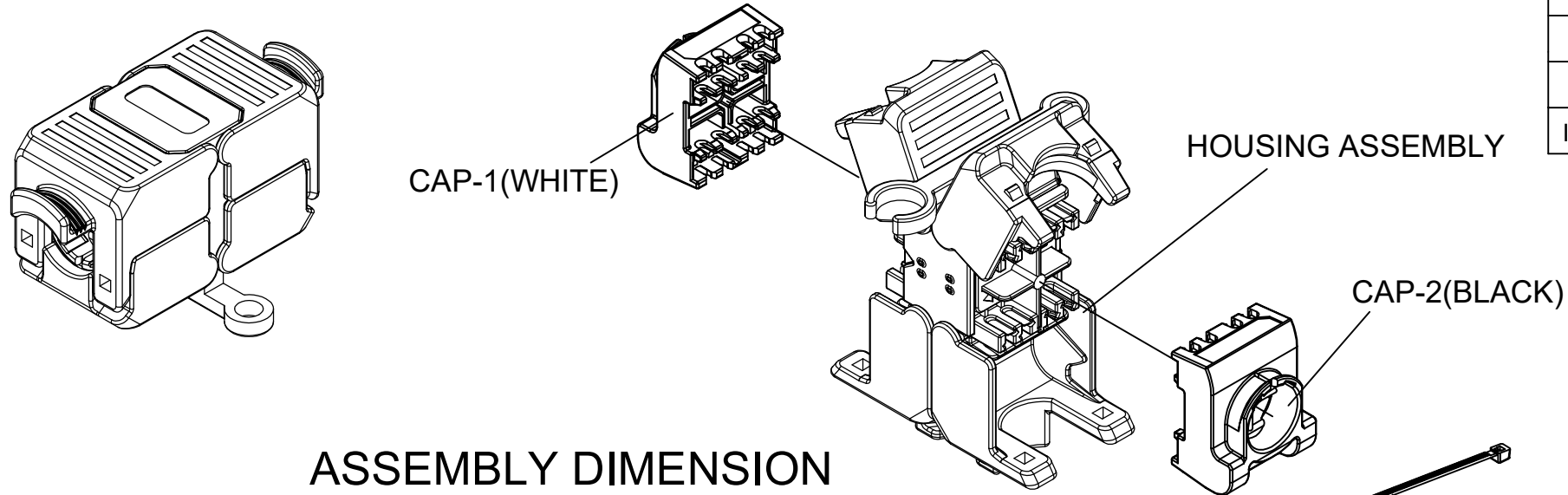

ASSEMBLY DIMENSION

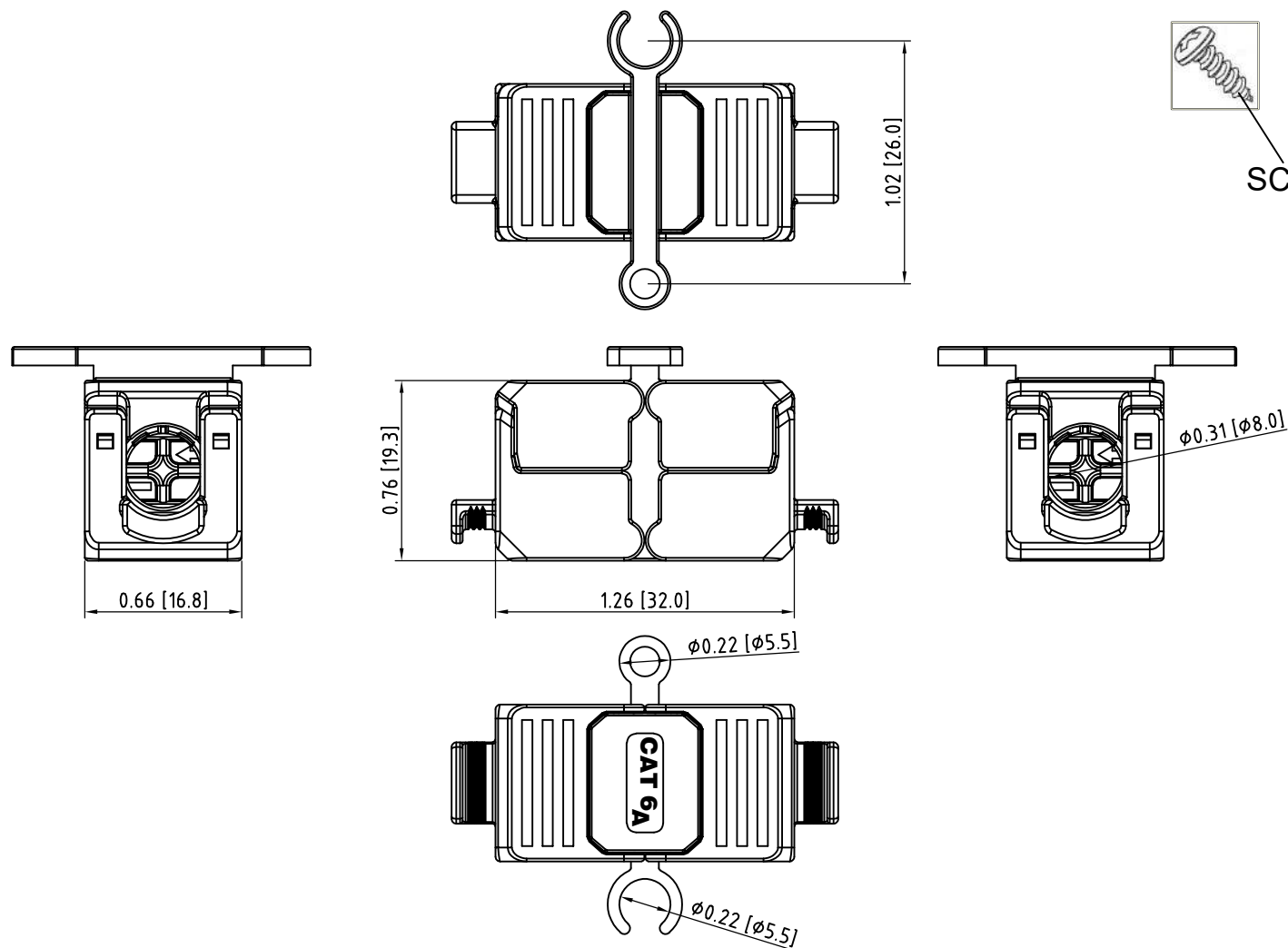

- NOTES:
- SUITABLE FOR USE IN EXISTING CABLE SYSTEMS UP TO CATEGORY 6A PERFORMANCE.
 - PHYSICAL
HOUSING: ZINC ALLOY, FULLY SHIELDED
IDC: PHOSPHOR BRONZE ALLOY WITH 100μIN TIN PLATING
 - ELECTRICAL
INSULATION RESISTANCE: 500MOHM MIN. @ 100VDC
DIELECTRIC WITHSTANDING VOLTAGE: IEC 60603-7
CONTACT TO CONTACT: 1000 VDC OR AC PEAK
CONTACT TO SHIELD: 1500 VDC OR AC PEAK
 - MECHANICAL
IDC WIRE GAUGE: 22 - 26 AWG, SOLID OR STRANDED
A SMALLER AWG CANNOT BE USED IN A PREVIOUSLY USED IDC.

SS-82120-002
PART NUMBER



THIRD ANGLE PROJECTION
DO NOT SCALE DRAWING
DRAWING IS SUBJECT TO CHANGE WITHOUT NOTICE
DIMENSIONS: INCHES [METRIC]
UNLESS OTHERWISE SPECIFIED TOLERANCES ARE ±.005 [0.13] ANGLES ARE ± 1°
SHEET NO. 1 OF 1

stewart
 CONNECTOR
 a bel group

11118 Susquehanna Trail South
Glen Rock, PA 17327-9199
(717) 235-7512
<http://www.stewartconnector.com>

| | | | |
|--|--|------------------|----------------|
| TITLE: CAT 6A TOOL-LESS CABLE SPLICER | | DRN BY: JE | DATE: 09/28/20 |
| THIS DRAWING AND THE SUBJECT MATTER SHOWN THEREON ARE CONFIDENTIAL AND THE PROPRIETARY PROPERTY OF STEWART CONNECTOR AND SHALL NOT BE REPRODUCED, COPIED, OR USED IN ANY MANNER WITHOUT PRIOR WRITTEN CONSENT OF STEWART CONNECTOR. ONE OR MORE U.S. PATENTS MAY APPLY TO THIS PRODUCT. FOR DETAILS, PLEASE VISIT: HTTP://BELFUSE.COM/STEWART/STEWART_PATENTS/ | | APPD BY: ADB | DATE: 10/15/20 |
| | | DWG NO. CT820036 | REV. A1 |