



PART NAME

NEMA DIE CAST ALUM. ENCLOSURE

PART No.

AN-1309-A & AN-1309-AB

REVISION DATE

9-30-15

UL LISTED FOR U.S. AND CANADA - FILE #E194432

UPDATE REPLACES PART NO. AN-1309(NATURAL) & AN-1309-G (DISCONTINUED GRAY)

DRAWING FOR REFERENCE

WE RESERVE THE RIGHT TO MAKE CHANGES TO OUR STANDARD PRODUCTS. PLEASE CONSULT WITH BUD INDUSTRIES PRIOR TO USING THIS DRAWING FOR DESIGN PURPOSE.

TYPE RATING 4, 4X, 6, 6P, 12 AND 13, COMPARE TO IP-68

80°C. MAXIMUM OPERATING TEMPERATURE

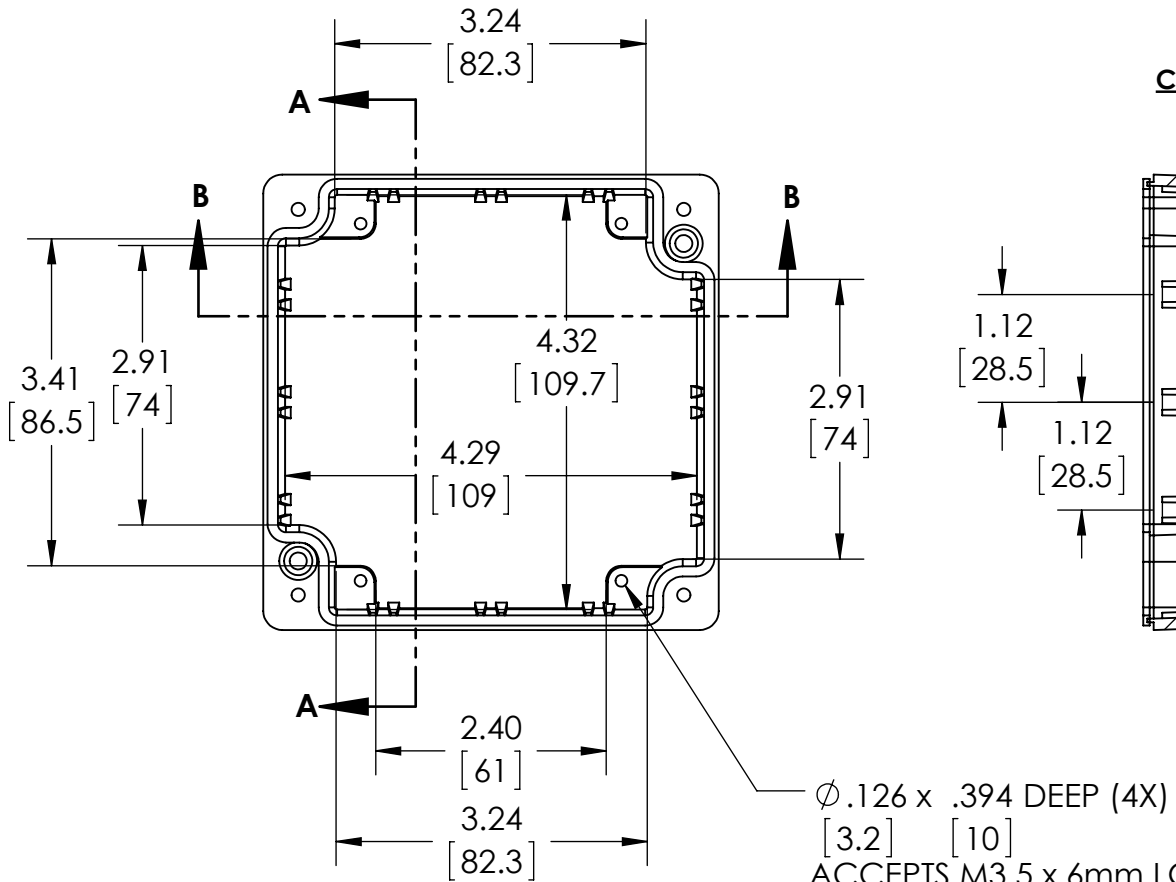

BODY COVER NOT SHOWN

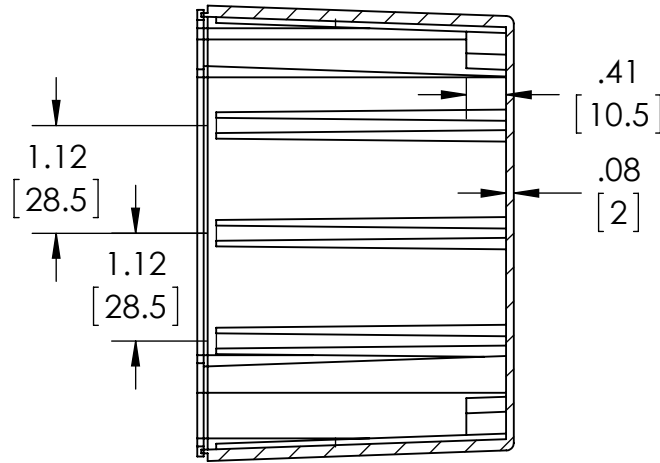

SECTION A-A

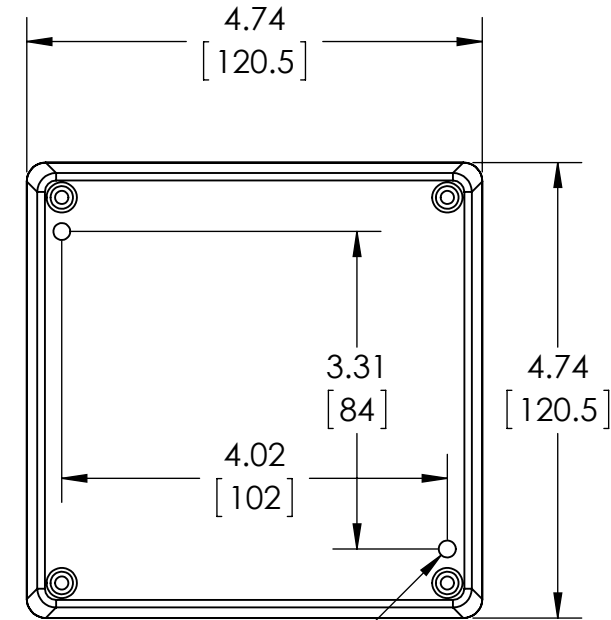

GASKET (NOT INSTALLED) MOLDED SILICONE GRAY

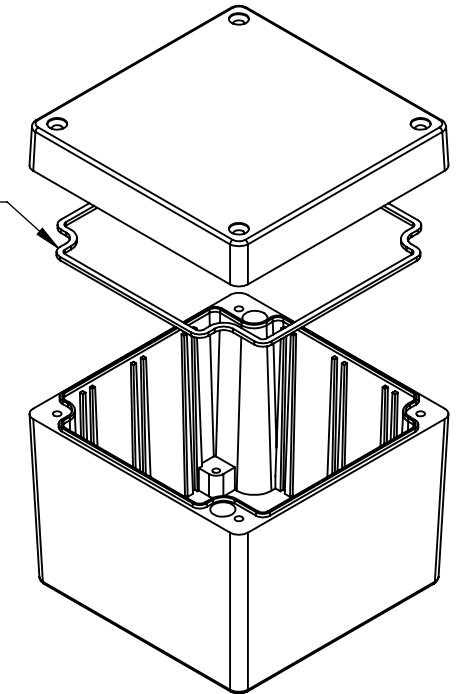

$\phi .126$ x .394 DEEP (4X)
 [3.2] [10]
 ACCEPTS M3.5 x 6mm LG.
 OR #6 x 1/4" LG.
 SELF-TAPPING SCREW
 (NOT SUPPLIED - FOR PCB
 MOUNTING)

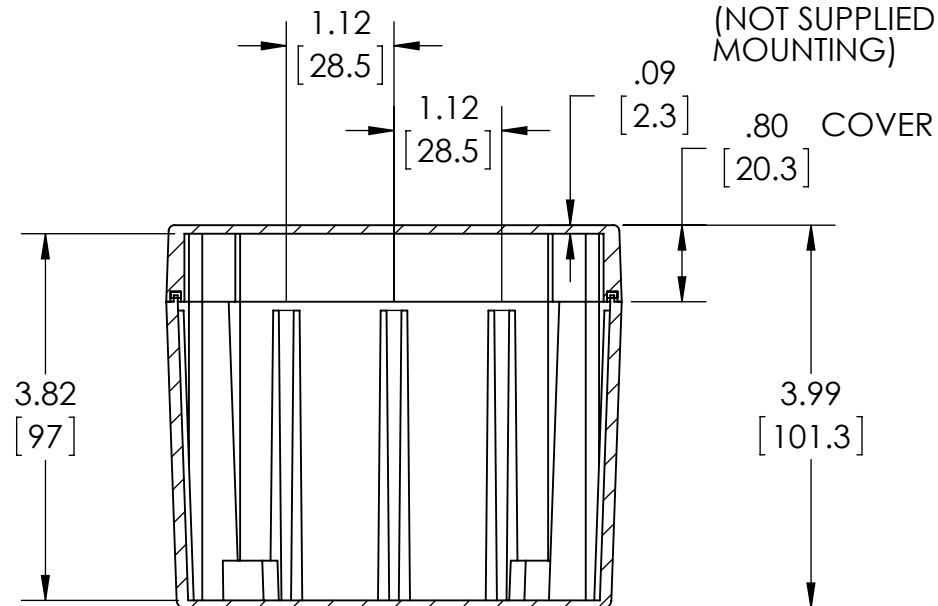

SECTION B-B

MATERIAL: BODY & COVER - ALUMINUM ALLOY #ADC-12

FINISH: NATURAL (SUFFIX -A)
SMOOTH BLACK POWDERCOAT (SUFFIX -AB)

FOUR (4) M4x0.7 x 32mm (1.26") LG. 90°CSK. HEAD STAINLESS STEEL SCREWS SUPPLIED FOR ASSEMBLY OF COVER TO BODY. APPLY AT 12 IN./LB. OF TORQUE.

OUTSIDE AND INSIDE DRAFT ANGLE: 2°
DIMENSIONS ARE INCH[MM]

OPTIONAL ACCESSORIES:
 PCB MOUNTING KIT #57-58
 INTERNAL PANEL #ANX-91309
 WALL MOUNTING BRACKETS #ANX-1390
 REPLACEMENT GASKET #1309GSKTSC

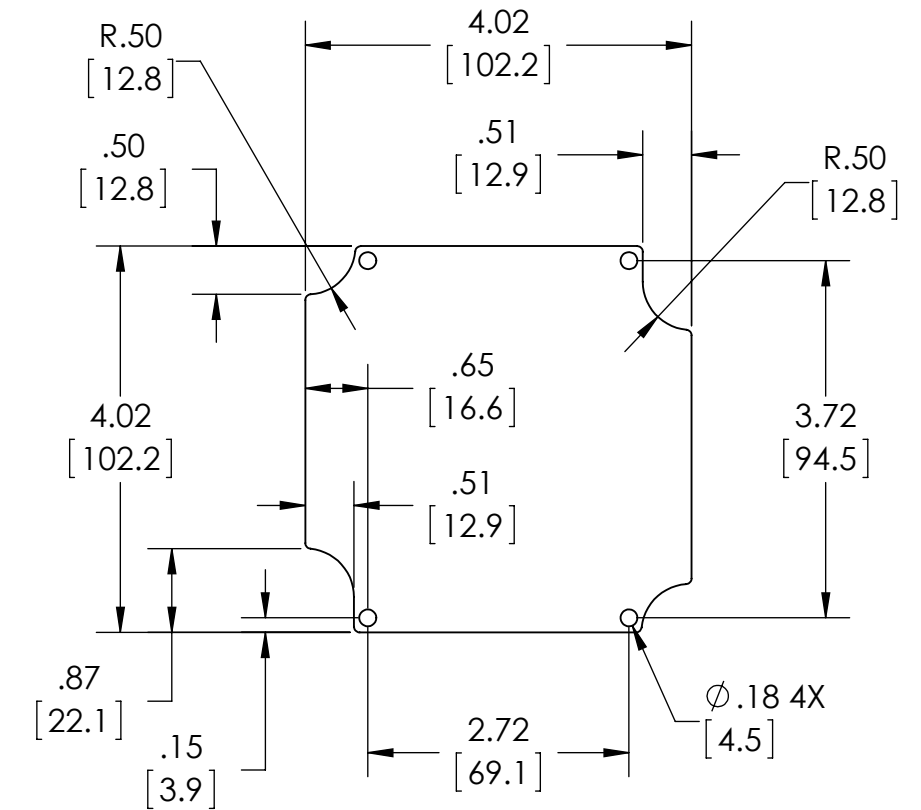

OPTIONAL INTERNAL PANEL AND SUGGESTED PC BOARD LAYOUT