

Copyright FCI.

spec ref	-	dr	Hai-Ling Liu	2015/06/23	projection	MM	size	A2	scale	3:1	
tolerance std	ASME Y14.5	eng	Hai-Ling Liu	2015/10/30		CARD EDGE	ecn no	-	rel level		Released
TOLERANCES UNLESS OTHERWISE SPECIFIED		chr	Terris Liu	2015/10/30			product family	HPCE STMT RECEPT	rel level	Released	Title
surface	ASME Y14.5	appr	Pai-Ming Zheng	2015/10/30	product family	HPCE STMT RECEPT	rel level	Released	Title		HPCE STMT RECEPT
linear	0.X ±0.5	www.fci.com		cat. no.	HPCE STMT RECEPT		rel level	Released	Title		HPCE STMT RECEPT
linear	0.XX ±0.25	www.fci.com		cat. no.	HPCE STMT RECEPT		rel level	Released	Title		HPCE STMT RECEPT
linear	0.XXX ±0.10	www.fci.com		cat. no.	HPCE STMT RECEPT		rel level	Released	Title		HPCE STMT RECEPT
angular	0° ±2°	www.fci.com		cat. no.	HPCE STMT RECEPT		rel level	Released	Title		HPCE STMT RECEPT

PDS: Rev :A

STATUS:Released

Printed: Oct 30, 2015

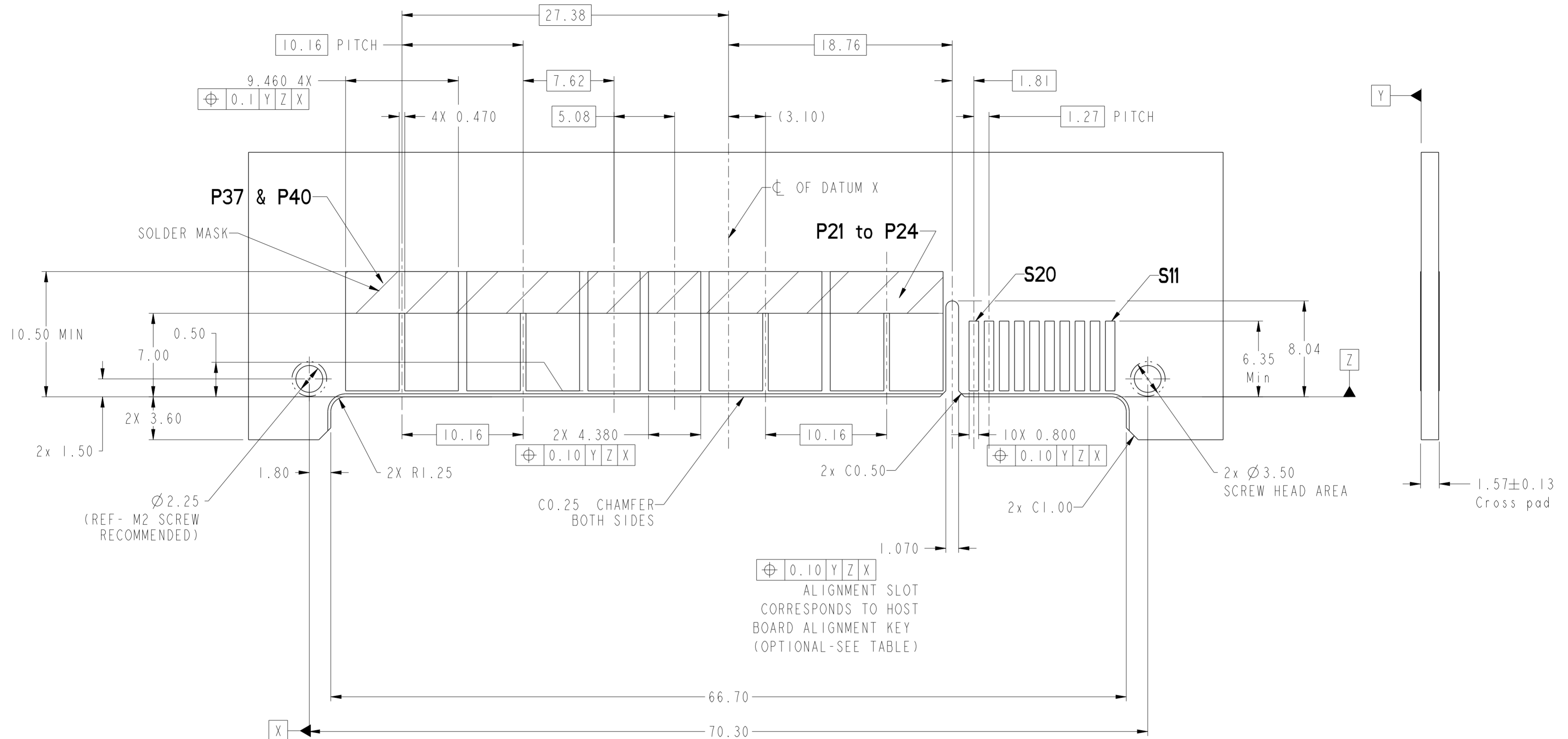

RECOMMENDED PCB LAYOUT AS VIEWED

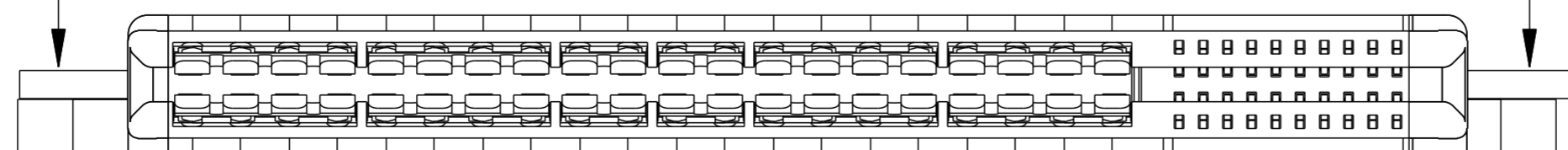

dr	Hai-Ling Liu	2015/06/23	projection	MM	size	A2	scale	2:1
eng	Hai-Ling Liu	2015/10/30			ecn no	-	rel level	Released
chr	Terris Liu	2015/10/30						
appr	Pei-Ming Zheng	2015/10/30	product family	-	dwg no	10135943	rev	A
www.fci.com			cat. no.	-	Product - Customer Drw		sheet 2 of 4	

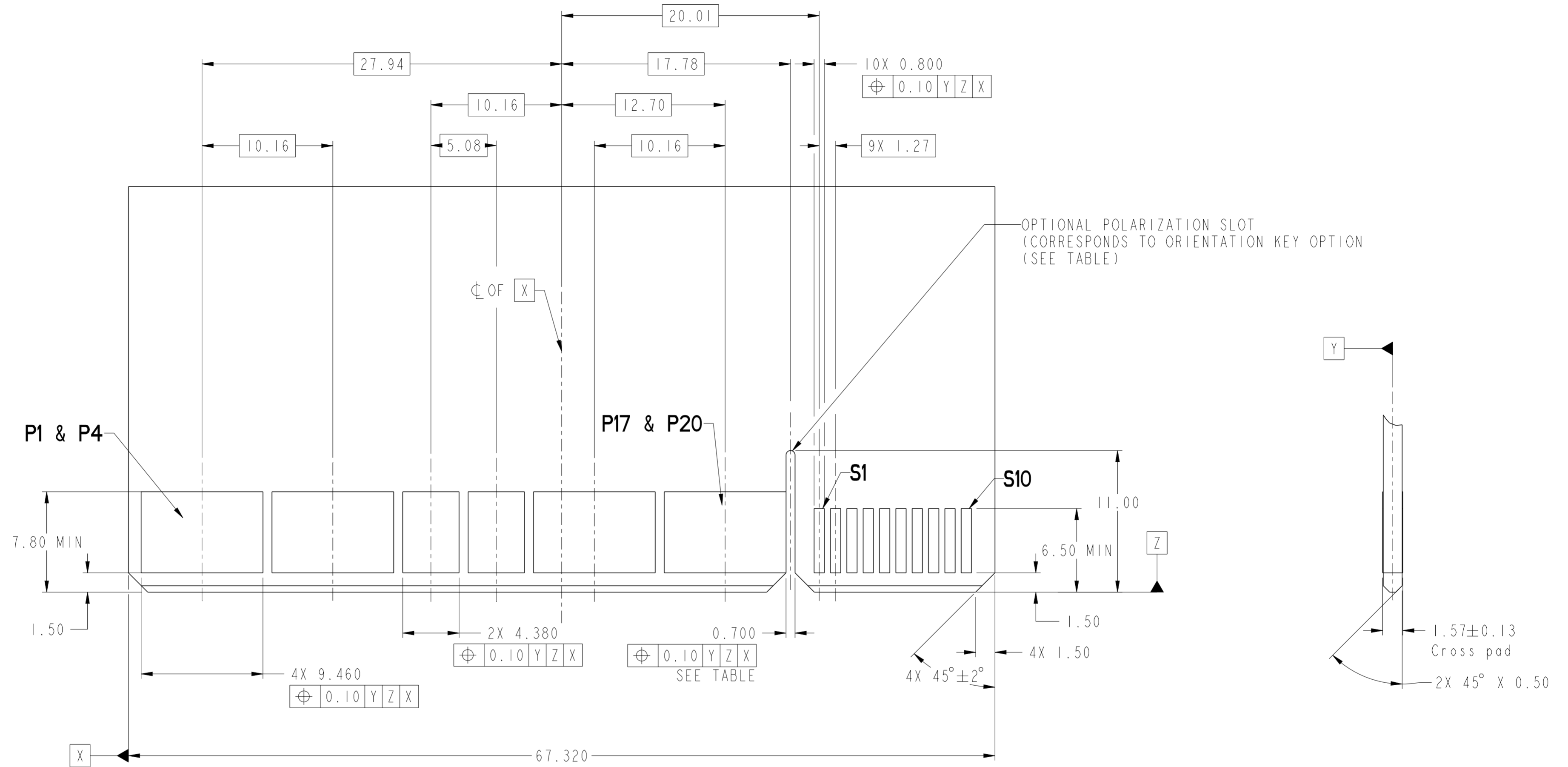

RECOMMENDED MATING BOARD FOOTPRINT

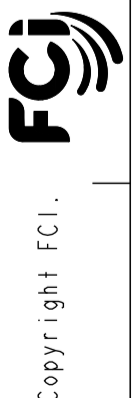

dr	Hai-Ling Liu	2015/06/23	projection	MM	size	A2	scale	1:1
eng	Hai-Ling Liu	2015/10/30			ecn no	-	rel level	Released
chr	Terris Liu	2015/10/30						
appr	Pai-Ming Zheng	2015/10/30	product family	-				
		title HPCE STMT RECEPT 40P20S WITH SPECIAL EAR			dwg no 10135943	rev A		
www.fci.com		cat. no.	-		Product - Customer Drw		sheet 3 of 4	

PART NUMBER	FEATURE A HOST BOARD ALIGNMENT KEY SEE NOTE 8	FEATURE B FRONT POLARIZATION KEY
10135943-001LF	YES	YES
10135943-002LF		NO

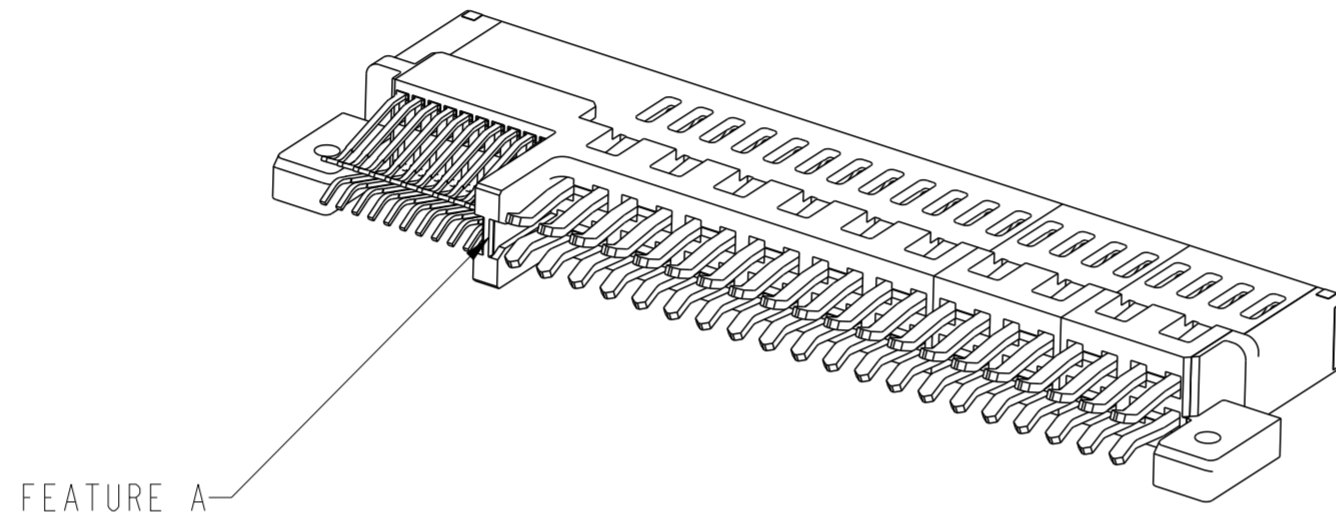
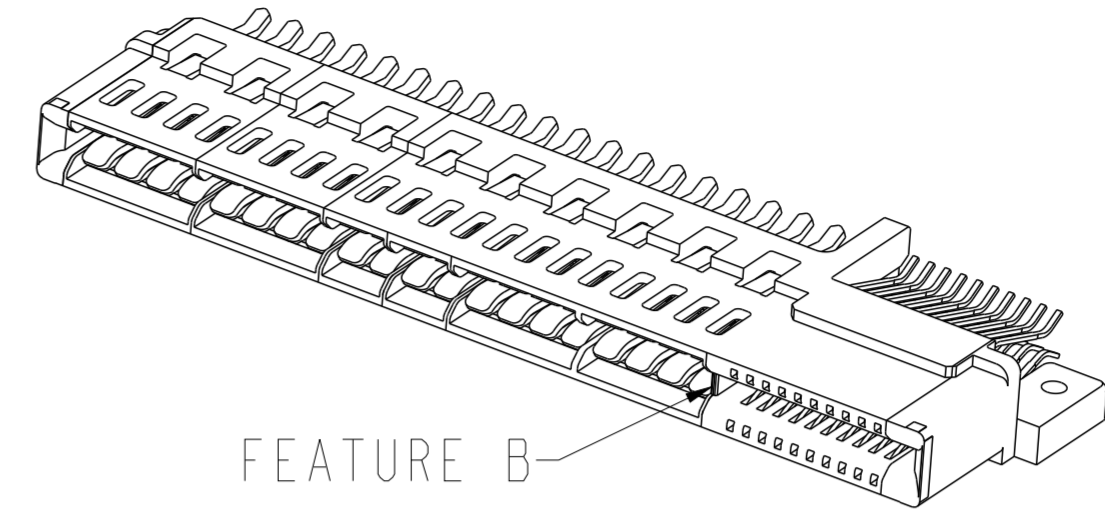

NOTES:

- CONNECTOR MATERIALS:
 HOUSING: HIGH TEMPERATURE THERMAL PLASTIC, BLACK
 UL 94V-0 COMPLIANT
 CONTACTS: HIGH PERFORMANCE COPPER ALLOY.
- CONTACT FINISH REF. GS-12-604 SECTION 5.2.
- PRODUCT SPECIFICATION: GS-12-604.
- APPLICATION SPECIFICATION: GS-20-128.
- PRODUCT MARKING (FCI - PART NUMBER & DATE CODE) ON HOUSING IN AREA SHOWN.
- PACKAGING MEETS FCI SPECIFICATION GS-14-937.
- HOST BOARD ALIGNMENT KEY IS RECOMMENDED TO ENSURE PROPER ALIGNMENT OF SOLDER TAILS WITH HOST BOARD PADS.

dr	Hai-Ling Liu	2015/06/23	projection	MM	size	A2	scale	4:1
eng	Hai-Ling Liu	2015/10/30			ecn no.	-	rel level	Released
chr	Terris Liu	2015/10/30						
appr	Pai-Ming Zheng	2015/10/30	product family	CARD EDGE	rel level	Released		
		title	HPCE STMT RECEPT 40P20S WITH SPECIAL EAR		dwg no.	10135943	rev	A
www.fci.com		cat. no.	-		Product - Customer Drw		sheet 4 of 4	