

140Mb/s Bi-directional Level Translator for Push-Pull Applications

Features

- 0.85V to 2.7V on A Port and 1.35V to 3.6V on B Port
- VCCA may be greater than, equal to, or less than VCCB
- High-Speed with 140 Mb/s Guaranteed Data Rate
- 100 pF Capacitive Drive Capability
- Low Bit-to-Bit Skew
- Overvoltage Tolerant Enable and I/O Pins
- Non-preferential Power-Up Sequencing
- Power-Off Protection
- Totally Lead-Free & Fully RoHS Compliant (Notes 1 & 2)
- Halogen and Antimony Free. “Green” Device (Note 3)
- For automotive applications requiring specific change control (i.e. parts qualified to AEC-Q100/101/200, PPAP capable, and manufactured in IATF 16949 certified facilities), please [contact us](mailto:contact_us) or your local Diodes representative.
<https://www.diodes.com/quality/product-definitions/>
- Packaging (Pb-free & Green):
 - 8-pin, UDFN1.2x1.6(XV)
 - 8-pin, MSOP (U)

Applications

- Mobile Phones, PDAs
- Other Portable Devices

Description

The PI4ULS3V302 is a 2-bit configurable dual-supply autosensing bidirectional level translator that does not require a direction control pin. The B and A ports are designed to track two different power supply rails, VCCB and VCCA respectively.

The PI4ULS3V302 offers the feature that the values of the VCCB and VCCA supplies are independent. Design flexibility is maximized because VCCA can be set to a value either greater than or less than the VCCB supply.

The PI4ULS3V302 has high output current capability, which allows the translator to drive high capacitive loads such as most high frequency EMI filters. Another feature of the PI4ULS3V302 is that each An and Bn channel can function as either an input or an output.

An Output Enable (EN) input is available to reduce the power consumption. The EN pin can be used to disable both I/O ports by putting them in 3-state which significantly reduces the supply current.

The PI4ULS3V302 is 2 kV System-Level ESD Capable.

Block Diagram

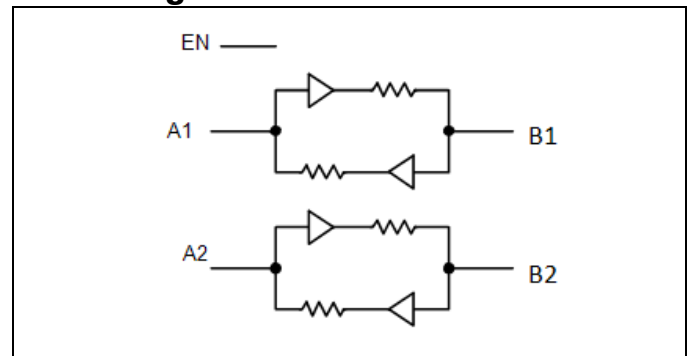
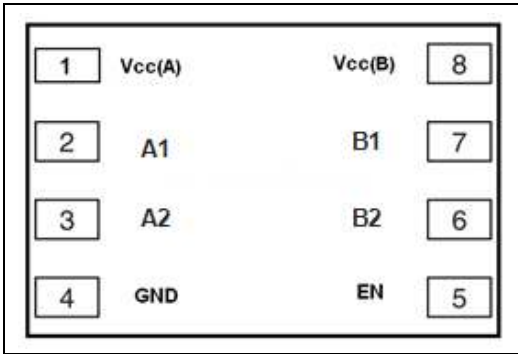

Figure 1: Block Diagram

Notes:

1. No purposely added lead. Fully EU Directive 2002/95/EC (RoHS), 2011/65/EU (RoHS 2) & 2015/863/EU (RoHS 3) compliant.
2. See <https://www.diodes.com/quality/lead-free/> for more information about Diodes Incorporated's definitions of Halogen- and Antimony-free, "Green" and Lead-free.
3. Halogen- and Antimony-free "Green" products are defined as those which contain <900ppm bromine, <900ppm chlorine (<1500ppm total Br + Cl) and <1000ppm antimony compounds.

Pin Configuration (Top View)



UDFN Package

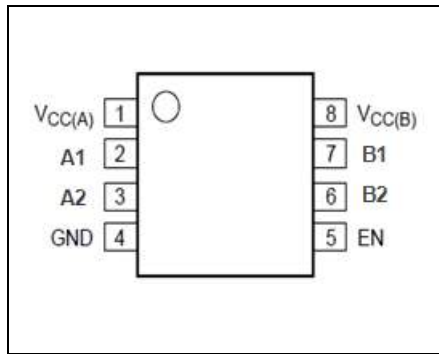

MSOP Package

Pin Description

Pin#	Pin Name	Type	Description
1	V _{CC(A)}	Power	A-port supply voltage. $0.85V \leq V_{CCA} \leq 2.7 V$
2	A1	I/O	Input/output A. Referenced to V _{CCA} .
3	A2	I/O	Input/output A. Referenced to V _{CCA} .
4	GND	GND	Ground.
5	EN	Input	Output enable (active High). Pull EN low to place all outputs in 3-state mode.
6	B2	I/O	Input/output B. Referenced to V _{CCB}
7	B1	I/O	Input/output B. Referenced to V _{CCB}
8	V _{CCB}	Power	B-port supply voltage. $1.35V \leq V_{CCB} \leq 3.6V$

Maximum Ratings

Storage Temperature	-65°C to +150°C
Junction Temperature, T _j	125°C
DC Supply Voltage port B	-0.5V to +4.6V
DC Supply Voltage port A	-0.5V to +3.6V
V _i (A) referenced DC Input / Output Voltage	-0.5V to +3.6V
V _i (B) referenced DC Input / Output Voltage	-0.5V to +4.6V
Enable Control Pin DC Input Voltage	-0.5V to +3.6V
DC Input Diode Current (V _i < GND)	-50mA
DC Output Diode Current (V _o < GND)	-50mA
DC Supply Current through V _{CCB}	±100mA
DC Supply Current through V _{CCA}	±100mA
DC Ground Current through Ground Pin	±100mA

Note:

Stresses greater than those listed under MAXIMUM RATINGS may cause permanent damage to the device. This is a stress rating only and functional operation of the device at these or any other conditions above those indicated in the operational sections of this specification is not implied. Exposure to absolute maximum rating conditions for extended periods may affect reliability.

Recommended Operation Conditions

Symbol	Parameter	Min.	Typ.	Max.	Unit	
V _{CCA}	A-side Positive DC Supply Voltage	0.85	-	2.7	V	
V _{CCB}	B-side Positive DC Supply Voltage	1.35	-	3.6	V	
V _I	Enable Control Pin Voltage	GND	-	2.7	V	
V _{IO}	Bus Input/Output Pin Voltage	I/O A	GND	-	2.7	V
		I/O B	GND	-	3.6	V
T _A	Operating Temperature Range	-40	-	+85	°C	
At/Av	Input Transition Rise or Rate, V _I , V _{IO} from 30% to 70% of V _{CC} ; V _{CC} = 3.3 V ± 0.3 V	0	-	10	ns	

DC Electrical Characteristics

Sym	Parameter	Test Conditions ^{*1}	V _{CCB} ^{*2} (V)	V _{CCA} ^{*3} (V)	-40°C to +85°C			Unit
					Min.	Typ. ^{*4}	Max.	
V _{IHB}	B port Input HIGH Voltage	-	1.35-3.6	0.85-2.7	2/3*V _{CCB}	-	-	V
V _{ILB}	B port Input LOW Voltage	-	1.35-3.6	0.85-2.7	-	-	1/3*V _{CCB}	V
V _{IHA}	A port Input HIGH Voltage	-	1.35-3.6	0.85-2.7	2/3*V _{CCA}	-	-	V
V _{ILA}	A port Input LOW Voltage	-	1.35-3.6	0.85-2.7	-	-	1/3*V _{CCA}	V
V _{IH}	Control Pin Input HIGH Voltage	T _A = +25°C	1.35-3.6	0.85-2.7	2/3*V _{CCA}	-	-	V
V _{IL}	Control Pin Input LOW Voltage	T _A = +25°C	1.35-3.6	0.85-2.7	-	-	1/3*V _{CCA}	V
V _{OHB}	B port Output HIGH Voltage	B port source current = 20μA	1.35-3.6	0.85-2.7	0.9*V _{CCB}	-	-	V
V _{OLB}	B port Output LOW Voltage	B port sink current = 20μA	1.35-3.6	0.85-2.7	-	-	0.2	V
V _{OHA}	A port Output HIGH Voltage	A port source current = 20μA	1.35-3.6	0.85-2.7	0.9*V _{CCA}	-	-	V
V _{OLA}	A port Output LOW Voltage	A port sink current = 20μA	1.35-3.6	0.85-2.7	-	-	0.2	V
I _{QVB}	V _{CCB} Supply Current	EN = V _{CCA} , I _O = 0A, (I/O_B = 0V or V _{CCB} , I/O_A = float)	1.35-3.6	0.85-2.7	-	-	1.5	μA
I _{QVA}	V _{CCA} Supply Current	or (I/O_B = float, I/O_A = 0V or V _{CCA})	1.35-3.6	0.85-2.7	-	-	1	μA
I _{TS-B}	B port Tristate Output Mode Supply Current	T _A = +25°C, EN = 0V (I/O_B = 0V or V _{CCB} , I/O_A = float) or	1.35-3.6	0.85-2.7	-	-	1.5	μA
I _{TS-A}	A port Tristate Output Mode Supply Current	(I/O_B = float, I/O_A = 0V or V _{CCA})	1.35-3.6	0.85-2.7	-	-	0.5	μA
I _{OZ}	I/O Tristate Output Mode Leakage Current	T _A = +25°C, EN = 0V	1.35-3.6	0.85-2.7	-	-	±1	μA
I _I	Control Pin Input Current	T _A = +25°C	1.35-3.6	0.85-2.7	-	-	±1	μA
I _{OFF}	Power Off Leakage Current	I/O_B = 0 to 3.6V, I/O_A = 0 to 2.5V	0	0	-	-	2	μA
			1.35-3.6	0	-	-	2	
			0	0.85-2.7	-	-	2	

- Note:**
- Normal test conditions are V_I = 0V, C_{IOB} ≤ 15pF and C_{IOA} ≤ 15pF, unless otherwise specified.
 - V_{CCB} is the supply voltage associated with the I/O B port, and B range from +1.35 V to 3.6 V under normal operating conditions.
 - V_{CCA} is the supply voltage associated with the I/O A port, and A range from +0.85 V to 2.7V under normal operating conditions.
 - Typical values are for V_{CCB} = +2.8V, V_{CCA} = +1.8V and T_A = +25°C. All units are production tested at T_A = +25°C. Limits over the operating temperature range are guaranteed by design.
 - When V_{CCA} < 1.0V, V_{IH} is 0.75*V_{CCA} (Min), V_{IL} is 0.25*V_{CCA} (Max)

Timing Characteristics

Sym	Parameter	Test Conditions *1	V _{CCB} *2 (V)	V _{CCA} *3(V)	-40°C to +85°C			Unit
					Min.	Typ. *4	Max.	
t _{R-B}	B port Rise Time	C _{IOB} = 15 pF	1.35-3.6	0.85-2.7	-	1.4	8.5	ns
			2.5-3.6	1.8-2.7	-	1.4	3.5	
t _{F-B}	B port Fall Time	C _{IOB} = 15 pF	1.35-3.6	0.85-2.7	-	1.2	8.5	ns
			2.5-3.6	1.8-2.7	-	1.2	3.5	
t _{R-A}	A port Rise Time	C _{IOA} = 15 pF	1.35-3.6	0.85-2.7	-	1.3	8.5	ns
			2.5-3.6	1.8-2.7	-	1.3	3.5	
t _{F-A}	A port Fall Time	C _{IOA} = 15 pF	1.35-3.6	0.85-2.7	-	1.6	8.5	ns
			2.5-3.6	1.8-2.7	-	1.6	3.5	
Z _{OB}	B port One-Shot Output Impedance	*5	1.5	0.9-2.5	-	37	-	Ω
			2.5		-	20	-	
			3.6		-	15	-	
Z _{OA}	A port One-Shot Output Impedance	*5	1.5-3.3	0.9	-	52	-	Ω
				1.8	-	17	-	
				2.5	-	15	-	
t _{PD,A-B}	Propagation Delay (Driving B port)	C _{IOB} = 15 pF	1.35-3.6	0.85-2.7	-	-	35	ns
			2.5-3.6	1.8-2.7	-	-	10	
		C _{IOB} = 30 pF	1.35-3.6	0.85-2.7	-	-	35	
			2.5-3.6	1.8-2.7	-	-	10	
		C _{IOB} = 50 pF	1.6-3.6	1.0-2.5	-	-	37	
			2.5-3.6	1.8-2.7	-	-	11	
		C _{IOB} = 100 pF	1.8-3.6	1.2-2.5	-	-	40	
			2.5-3.6	1.8-2.7	-	-	13	
t _{PD,B-A}	Propagation Delay (Driving A port)	C _{IOA} = 15 pF	1.35-3.6	0.85-2.7	-	-	35	ns
			2.5-3.6	1.8-2.7	-	-	10	
		C _{IOA} = 30 pF	1.35-3.6	0.85-2.7	-	-	35	
			2.5-3.6	1.8-2.7	-	-	10	
		C _{IOA} = 50 pF	1.6-3.6	1.0-2.5	-	-	37	
			2.5-3.6	1.8-2.7	-	-	11	
		C _{IOA} = 100 pF	1.8-3.6	1.2-2.5	-	-	40	
			2.5-3.6	1.8-2.7	-	-	13	
t _{SK}	Channel-to-Channel Skew	C _{IOB} = 15pF, C _{IOA} = 15pF*5	1.35-3.6	0.85-2.7	-	-	0.15	ns
t _{EN-B} (t _{PZH})	B port Output Enable Time	C _{IOB} = 15pF, I/O_A = V _{CCA}	1.35-3.6	0.85-2.7	-	240	400	ns
			2.5-3.6	1.8-2.7	-	-	160	
t _{EN-B} (t _{PZL})	B port Output Enable Time	C _{IOB} = 15pF, I/O_A = 0V	1.35-3.6	0.85-2.7	-	80	150	ns
			2.5-3.6	1.8-2.7	-	-	130	
t _{EN-A} (t _{PZH})	A port Output Enable Time	C _{IOA} = 15pF, I/O_B = V _{CCB}	1.35-3.6	0.85-2.7	-	130	250	ns
			2.5-3.6	1.8-2.7	-	-	160	
t _{EN-A} (t _{PZL})	A port Output Enable Time	C _{IOA} = 15 pF, I/O_B = 0 V	1.35-3.6	0.85-2.7	-	100	200	ns
			2.5-3.6	1.8-2.7	-	-	130	
t _{OIS-B} (t _{PHZ})	B port Output Disable Time	C _{IOB} = 15pF, I/O_A = V _{CCA}	1.35-3.6	0.85-2.7	-	-	210	ns
			2.5-3.6	1.8-2.7	-	-	210	
t _{OIS-B} (t _{PLZ})	B port Output Disable Time	C _{IOB} = 15pF, I/O_A = 0V	1.35-3.6	0.85-2.7	-	-	175	ns
			2.5-3.6	1.8-2.7	-	-	175	
t _{OIS-B} (t _{PHZ})	A port Output Disable Time	C _{IOB} = 15pF, I/O_A = V _{CCA}	1.35-3.6	0.85-2.7	-	-	210	ns
			2.5-3.6	1.8-2.7	-	-	210	
t _{OIS-B} (t _{PLZ})	A port Output Disable Time	C _{IOB} = 15pF, I/O_A = 0V	1.35-3.6	0.85-2.7	-	-	175	ns
			2.5-3.6	1.8-2.7	-	-	175	

Timing Characteristics (Cont.)

Sym	Parameter	Test Conditions *1	V _{CCB} *2 (V)	V _{CCA} *3(V)	-40°C to +85°C			Unit
					Min.	Typ. *4	Max.	
M _{IDR}	Maximum Data Rate	C _{IO} = 15pF	1.35-3.6	0.85-2.7	50	-	-	mbps
			2.5-3.6	1.8-2.7	140	-	-	
		C _{IO} = 30pF	1.35-3.6	0.85-2.7	40	-	-	
			2.5-3.6	1.8-2.7	120	-	-	
		C _{IO} = 50pF	1.6-3.6	1.0-2.7	30	-	-	
			2.5-3.6	1.8-2.7	100	-	-	
		C _{IO} = 100pF	1.8-3.6	1.2-2.7	20	-	-	
			2.5-3.6	1.8-2.7	60	-	-	

Notes:

1. Normal test conditions are V_I = 0 V, C_{IOB} ≤ 15pF and C_{IOA} ≤ 15pF, unless otherwise specified.
2. V_{CCB} is the supply voltage associated with the I/O B port, and B ranges from +1.35 V to 3.6 V under normal operating conditions.
3. V_{CCA} is the supply voltage associated with the I/O A port, and A ranges from +0.85 V to 2.7V under normal operating conditions.
4. Typical values are for B = +2.8V, A = +1.8V and T_A = +25°C. All units are production tested at T_A = +25°C. Limits over the operating temperature range are guaranteed by design.

Power Consumption (T_A=+25°C)

Sym *1	Parameter	Test Conditions	V _{CCB} *2 (V)	V _{CCA} *3(V)	Typ.	Unit
C _{PD_VCCA}	A = Input port, B = Output Port	C _{Load} = 0, f = 1MHz, EN = V _{CCA} (outputs enabled)	1.35-3.6	0.85-2.7	40	pF
	B = Input port, A = Output Port					
C _{PD_VCCB}	A = Input port, B = Output Port	C _{Load} = 0, f = 1MHz, EN = V _{CCA} (outputs enabled)	1.35-3.6	0.85-2.7	40	pF
	B = Input port, A = Output Port					
C _{PD_VCCA}	A = Input port, B = Output Port	C _{Load} = 0, f = 1MHz, EN = GND(outputs disabled)	1.35-3.6	0.85-2.7	1	pF
	B = Input port, A = Output Port					
C _{PD_VCCB}	A = Input port, B = Output Port	C _{Load} = 0, f = 1MHz, EN = GND(outputs disabled)	1.35-3.6	0.85-2.7	1	pF
	B = Input port, A = Output Port					

Notes:

1. C_{PD_VCCA} and C_{PD_VCCB} are defined as the value of the IC's equivalent capacitance from which the operating current can be calculated for the A and B power supplies, respectively. I_{CC} = I_{CC} (dynamic) + I_{CC} (static) ≈ I_{CC}(operating) ≈ CPD x V_{CC} x f_{IN} x NSW where I_{CC} = I_{CC-VCCB} + I_{CC-VCCA} and NSW = total number of outputs switching.
2. V_{CCB} is the supply voltage associated with the I/O B port, and V_{CCB} ranges from +1.35V to 3.6V under normal operating conditions.
3. V_{CCA} is the supply voltage associated with the I/O A port, and V_{CCA} range from +0.85 V to 2.7V under normal operating conditions.
4. Typical values are at T_A = +25°C.

Test Circuits

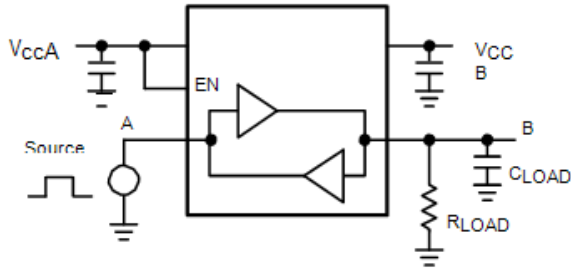

Figure 2. Driving A Test Circuit

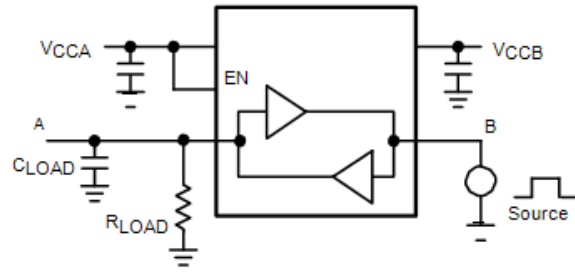

Figure 3. Driving B Test Circuit

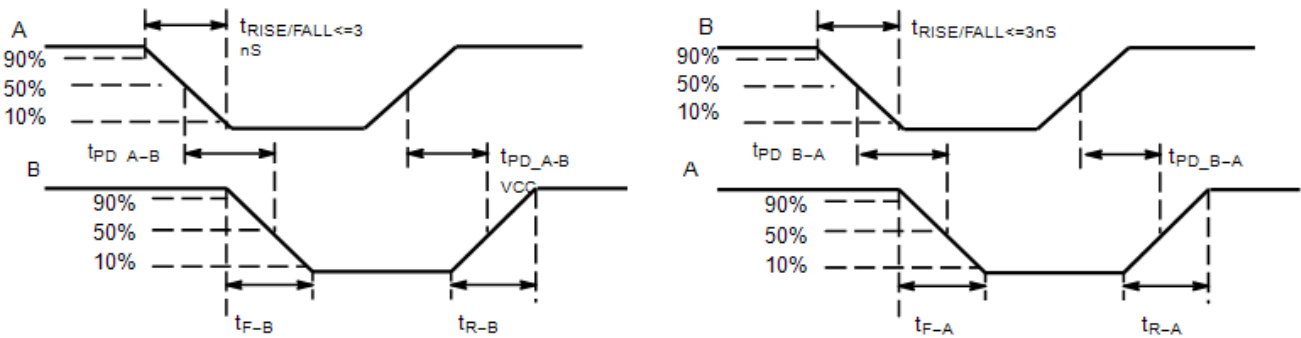
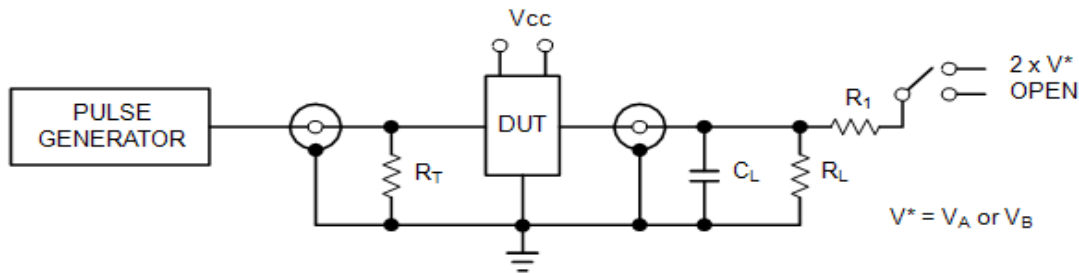

Figure 4. Definition of Timing Specification Parameters



Test	Switch
t_{PZH}, t_{PHZ}	Open
t_{PZL}, t_{PLZ}	$2 \times V^*$

$C_L = 15 \text{ pF}$ or equivalent (Includes jig and probe capacitance)
 $R_L = R_1 = 50 \text{ k}\Omega$ or equivalent
 $R_T = Z_{OUT}$ of pulse generator (typically 50Ω)
 $V^* = V_A$ or V_B for A or B measurements, respectively.

Figure 5. Test Circuit for Enable/Disable Time Measurement

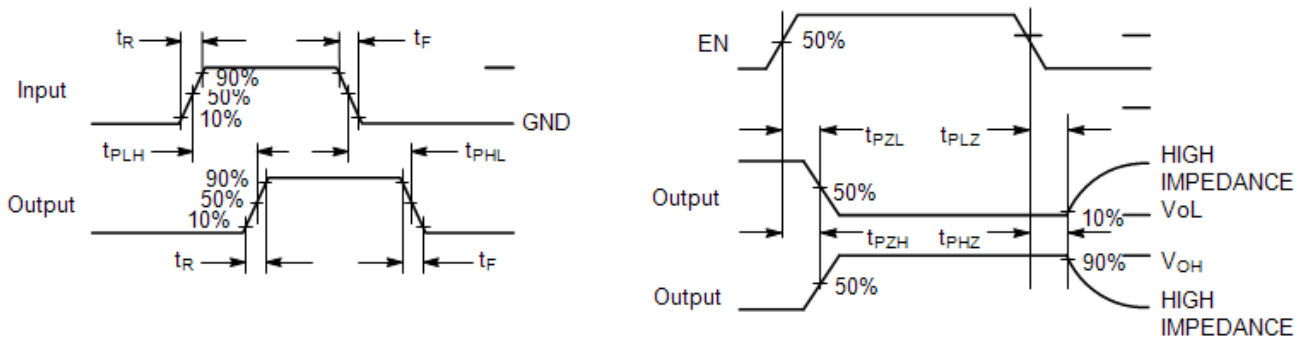

Figure 6. Timing Definitions for Propagation Delays and Enable/Disable Measurement

Functional Description

The PI4ULS3V302 is a 2-bit configurable dual-supply autosensing bidirectional level translator that does not require a direction control pin. The B and A ports are designed to track two different power supply rails, VCCB and VCCA respectively.

The PI4ULS3V302 offers the feature that the values of the VCCB and VCCA supplies are independent. Design flexibility is maximized because VCCA can be set to a value either greater than or less than the VCCB supply.

The PI4ULS3V302 has high output current capability, which allows the translator to drive high capacitive loads such as most high frequency EMI filters. Another feature of the PI4ULS3V302 is that each An and Bn channel can function as either an input or an output.

An Output Enable (EN) input is available to reduce the power consumption. The EN pin can be used to disable both I/O ports by putting them in 3-state which significantly reduces the supply current.

Application Information

Level Translator Architecture

The PI4ULS3V302 auto-sense translator provides bi-directional logic voltage level shifting to transfer data in multiple supply voltage systems. These level translators have two supply voltages, VCCA and VCCB, which set the logic levels on the input and output sides of the translator. When used to transfer data from the I/O VCCA to the I/O VCCB ports, input signals referenced to the VCCA supply are translated to output signals with a logic level matched to VCCB. In a similar manner, the I/O VCCB to I/O VCCA translation shifts input signals with a logic level compatible to VCCB to an output signal matched to VCCA. The PI4ULS3V302 translator consists of bi-directional channels that independently determine the direction of the data flow without requiring a directional pin. One-shot circuits are used to detect the rising or falling input signals. In addition, the one-shots decrease the rise and fall times of the output signal for high-to-low and low-to-high transitions.

Input Driver Requirements

Auto-sense translators such as the PI4ULS3V302 have a wide bandwidth, but a relatively small DC output current rating. The high bandwidth of the bi-directional I/O circuit is used to quickly transform from an input to an output driver and vice versa. The I/O ports have a modest DC current output specification so that the output driver can be over driven when data is sent in the opposite direction. For proper operation, the input driver to the auto-sense translator should be capable of driving 3mA of peak output current. The bi-directional configuration of the translator results in both input stages being active for a very short time period. Although the peak current from the input signal circuit is relatively large, the average current is small and consistent with a standard CMOS input stage. Enable Input (EN) The PI4ULS3V302 translator has an Enable pin (EN) that provides tri-state operation at the I/O pins. Driving the Enable pin to a low logic level minimizes the power consumption of the device and drives the I/O VCCB and I/O VCCA pins to a high impedance state. Normal translation operation occurs when the EN pin is equal to a logic high signal. The EN pin is referenced to the VCCA supply and has Over-Voltage Tolerant (OVT) protection.

Uni-Directional versus Bi-Directional Translation

The PI4ULS3V302 translator can function as a non-inverting uni-directional translator. One advantage of using the translator as a uni-directional device is that each I/O pin can be configured as either an input or output. The configurable input or output feature is especially useful in applications such as SPI that use multiple uni-directional I/O lines to send data to and from a device. The flexible I/O port of the auto sense translator simplifies the trace connections on the PCB.

Power Supply Guidelines

The values of the VCCA and VCCB supplies can be set to anywhere in range 0.85-2.7V and 1.35-3.6V. Design flexibility is maximized because VCCA may be either greater than or less than the VCCB supply. The sequencing of the power supplies will not damage the device during power-up operation. In addition, the I/O VCCB and I/O VCCA pins are in the high impedance state if either supply voltage is equal to 0V. For optimal performance, 0.01 to 0.1µF decoupling capacitors should be used on the VCCA and VCCB power supply pins. Ceramic capacitors are a good design choice to filter and bypass any noise signals on the voltage lines to the ground plane of the PCB. The noise immunity will be maximized by placing the capacitors as close as possible to the supply and ground pins, along with minimizing the PCB connection traces. The PI4ULS3V302 translators have a power down feature that provides design flexibility. The output ports are disabled when either power supply is off (VCCA or VCCB = 0V). This feature causes all of the I/O pins to be in the power saving high impedance state.

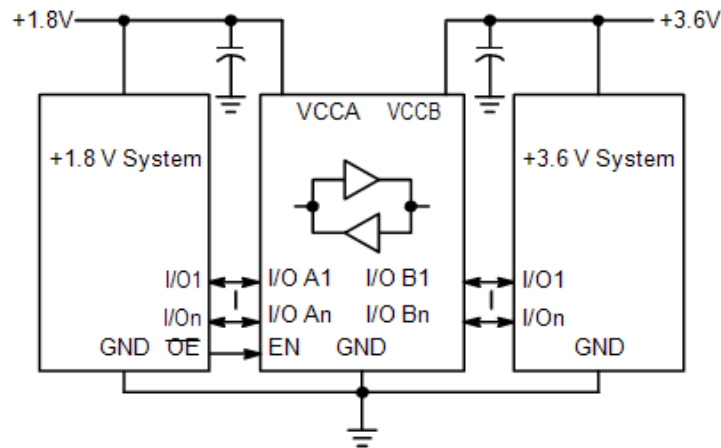

Figure 7. Typical Application Circuit

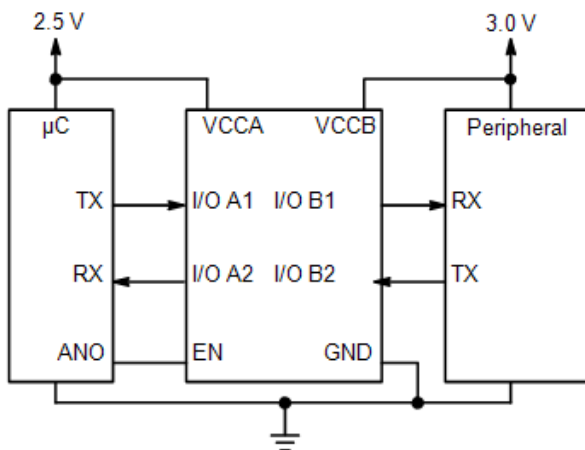

Figure 8. Application Example for A < B

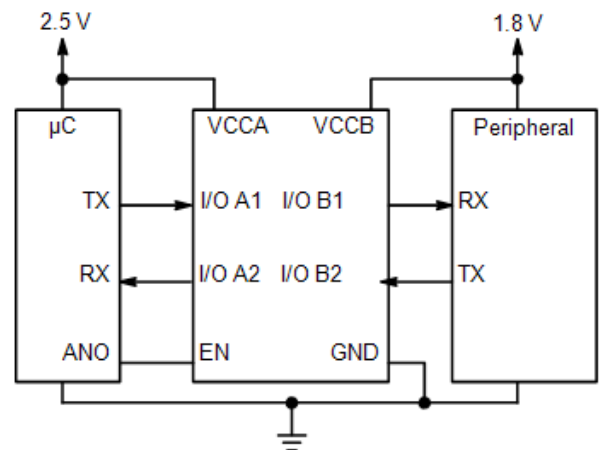
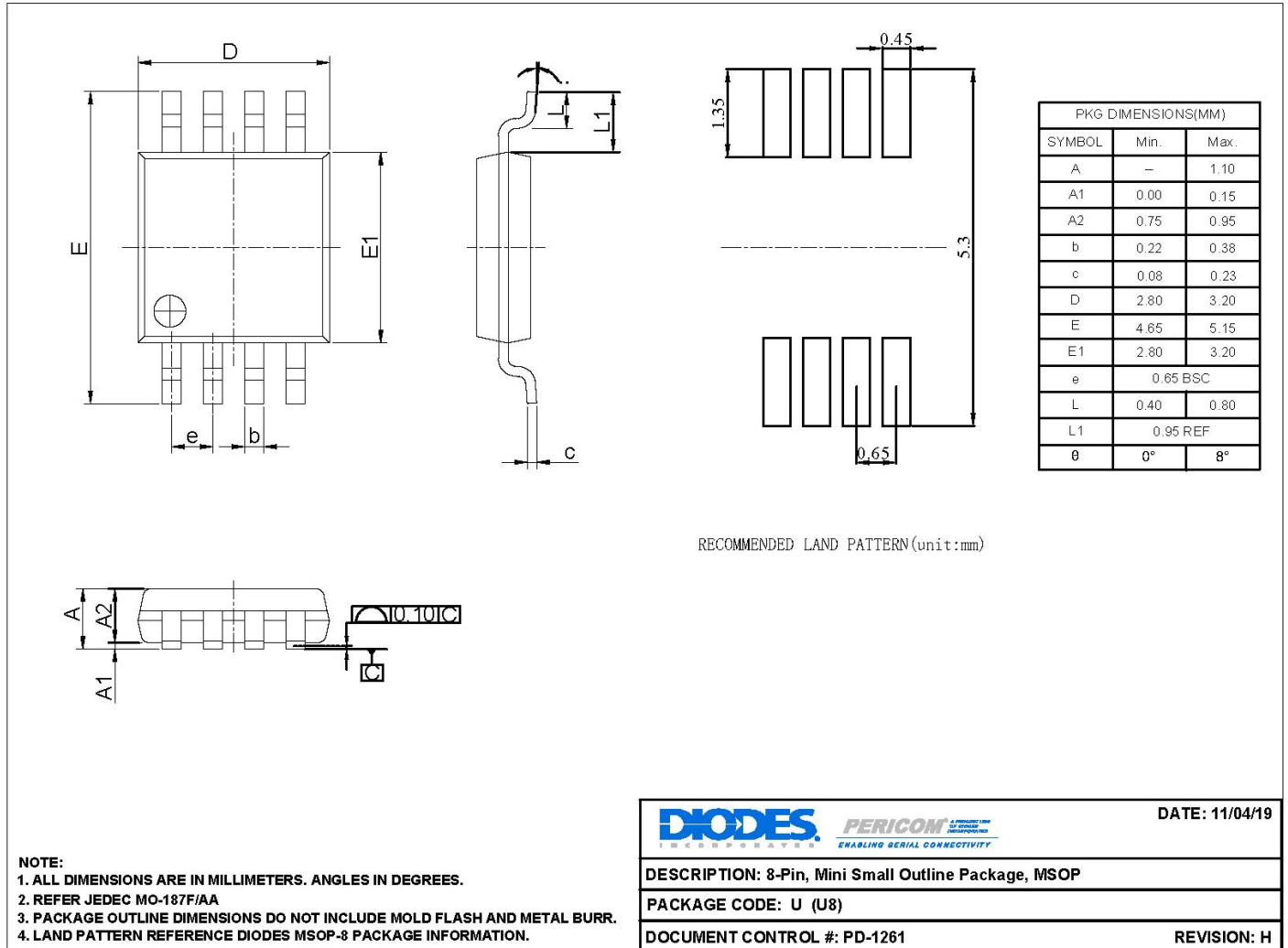

Figure 9. Application Example for A > B

Part Marking

Top mark not available at this time. To obtain advance information regarding the top mark, please contact your local sales representative.

Packaging Mechanical
8-MSOP (U)



19-1147

8-UDFN (XV)

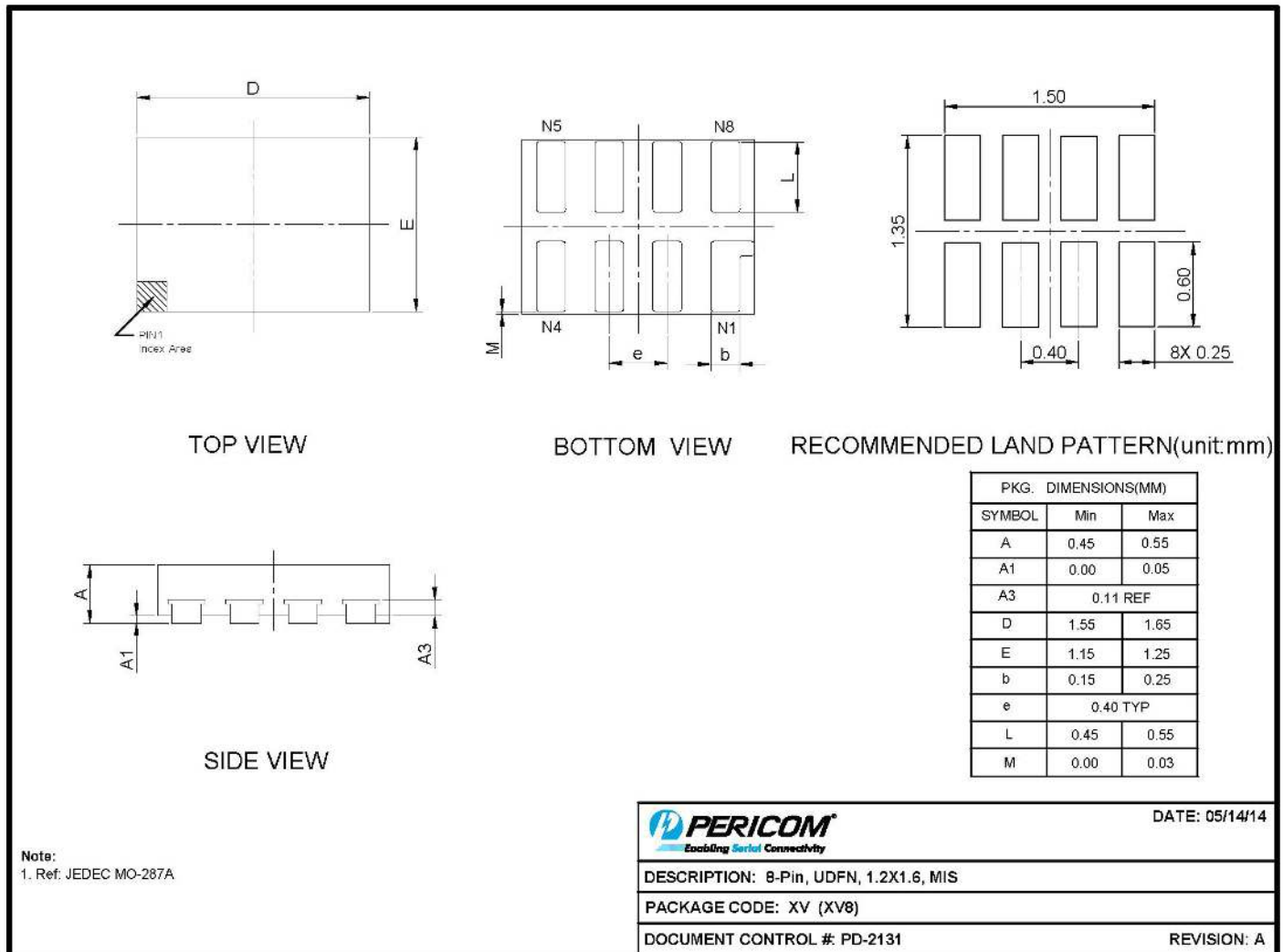

14-0141

For latest package info.

please check: <http://www.diodes.com/design/support/packaging/pericom-packaging/packaging-mechanicals-and-thermal-characteristics/>

Ordering Information

Part Number	Package Code	Package Description
PI4ULS3V302UEX	U	8-Pin, Mini Small Outline Package (MSOP)
PI4ULS3V302XVEX	XV	8-Pin, 1.2x1.6, MIS (UDFN)

Notes:

- No purposely added lead. Fully EU Directive 2002/95/EC (RoHS), 2011/65/EU (RoHS 2) & 2015/863/EU (RoHS 3) compliant.
- See <https://www.diodes.com/quality/lead-free/> for more information about Diodes Incorporated's definitions of Halogen- and Antimony-free, "Green" and Lead-free.
- Halogen- and Antimony-free "Green" products are defined as those which contain <900ppm bromine, <900ppm chlorine (<1500ppm total Br + Cl) and <1000ppm antimony compounds.
- E = Pb-free and Green
- X suffix = Tape/Reel

IMPORTANT NOTICE

1. DIODES INCORPORATED AND ITS SUBSIDIARIES (“DIODES”) MAKE NO WARRANTY OF ANY KIND, EXPRESS OR IMPLIED, WITH REGARDS TO ANY INFORMATION CONTAINED IN THIS DOCUMENT, INCLUDING, BUT NOT LIMITED TO, THE IMPLIED WARRANTIES OF MERCHANTABILITY, FITNESS FOR A PARTICULAR PURPOSE OR NON-INFRINGEMENT OF THIRD PARTY INTELLECTUAL PROPERTY RIGHTS (AND THEIR EQUIVALENTS UNDER THE LAWS OF ANY JURISDICTION).

2. The Information contained herein is for informational purpose only and is provided only to illustrate the operation of Diodes products described herein and application examples. Diodes does not assume any liability arising out of the application or use of this document or any product described herein. This document is intended for skilled and technically trained engineering customers and users who design with Diodes products. Diodes products may be used to facilitate safety-related applications; however, in all instances customers and users are responsible for (a) selecting the appropriate Diodes products for their applications, (b) evaluating the suitability of the Diodes products for their intended applications, (c) ensuring their applications, which incorporate Diodes products, comply the applicable legal and regulatory requirements as well as safety and functional-safety related standards, and (d) ensuring they design with appropriate safeguards (including testing, validation, quality control techniques, redundancy, malfunction prevention, and appropriate treatment for aging degradation) to minimize the risks associated with their applications.

3. Diodes assumes no liability for any application-related information, support, assistance or feedback that may be provided by Diodes from time to time. Any customer or user of this document or products described herein will assume all risks and liabilities associated with such use, and will hold Diodes and all companies whose products are represented herein or on Diodes’ websites, harmless against all damages and liabilities.

4. Products described herein may be covered by one or more United States, international or foreign patents and pending patent applications. Product names and markings noted herein may also be covered by one or more United States, international or foreign trademarks and trademark applications. Diodes does not convey any license under any of its intellectual property rights or the rights of any third parties (including third parties whose products and services may be described in this document or on Diodes’ website) under this document.

5. Diodes products are provided subject to Diodes’ Standard Terms and Conditions of Sale (<https://www.diodes.com/about/company/terms-and-conditions/terms-and-conditions-of-sales/>) or other applicable terms. This document does not alter or expand the applicable warranties provided by Diodes. Diodes does not warrant or accept any liability whatsoever in respect of any products purchased through unauthorized sales channel.

6. Diodes products and technology may not be used for or incorporated into any products or systems whose manufacture, use or sale is prohibited under any applicable laws and regulations. Should customers or users use Diodes products in contravention of any applicable laws or regulations, or for any unintended or unauthorized application, customers and users will (a) be solely responsible for any damages, losses or penalties arising in connection therewith or as a result thereof, and (b) indemnify and hold Diodes and its representatives and agents harmless against any and all claims, damages, expenses, and attorney fees arising out of, directly or indirectly, any claim relating to any noncompliance with the applicable laws and regulations, as well as any unintended or unauthorized application.

7. While efforts have been made to ensure the information contained in this document is accurate, complete and current, it may contain technical inaccuracies, omissions and typographical errors. Diodes does not warrant that information contained in this document is error-free and Diodes is under no obligation to update or otherwise correct this information. Notwithstanding the foregoing, Diodes reserves the right to make modifications, enhancements, improvements, corrections or other changes without further notice to this document and any product described herein. This document is written in English but may be translated into multiple languages for reference. Only the English version of this document is the final and determinative format released by Diodes.

8. Any unauthorized copying, modification, distribution, transmission, display or other use of this document (or any portion hereof) is prohibited. Diodes assumes no responsibility for any losses incurred by the customers or users or any third parties arising from any such unauthorized use.

Copyright © 2021 Diodes Incorporated

www.diodes.com