

## Digital controlled stereo audio processor with loudness

### Features

- Input multiplexer:
  - 3 stereo inputs
  - Selectable input gain for optimal adaptation to different sources
- Volume control in 1.25 dB steps
- Loudness function
- Treble and bass control
- Four speaker attenuators:
  - 4 independent speakers control in 1.25 dB steps for balance and fader facilities
  - Independent mute function
- All functions programmable via serial I<sup>2</sup>C bus

### Description

The TDA7303 is a volume, tone (bass and treble) balance (left/right) and fader (front/rear) processor for quality audio applications in car radio, Hi-Fi and portable systems.

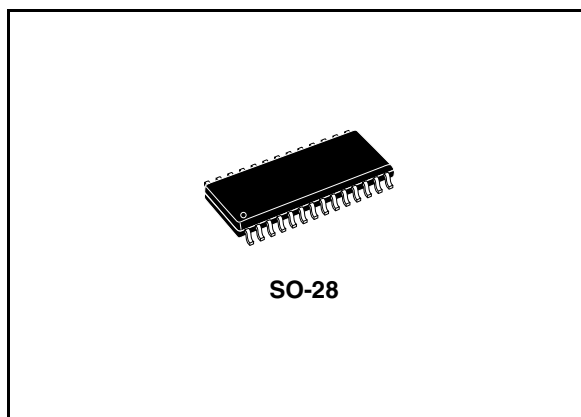

Selectable input gain and external loudness function are provided. Control is accomplished by serial I<sup>2</sup>C bus microprocessor interface.

The AC signal setting is obtained by resistor networks and switches combined with operational amplifiers.

Thanks to the used bipolar/CMOS technology, low distortion, low noise and low DC stepping are obtained.

**Table 1. Device summary**

Order code	Package	Packing
TDA7303	SO-28	Tray
TDA7303TR	SO-28	Tape and reel

# Contents

<b>1</b>	<b>Block, test and pin diagrams</b> .....	<b>5</b>
1.1	Block diagram .....	5
1.2	Test circuit .....	6
1.3	Pin connection .....	6
<b>2</b>	<b>Electrical specifications</b> .....	<b>7</b>
2.1	Absolute maximum ratings .....	7
2.2	Quick reference data .....	7
2.3	Thermal data .....	7
2.4	Electrical characteristics .....	8
2.5	Electrical characteristics curves .....	10
<b>3</b>	<b>I<sup>2</sup>C bus interface</b> .....	<b>13</b>
3.1	Data validity .....	13
3.2	Start and stop conditions .....	13
3.3	Byte format .....	13
3.4	Acknowledge .....	13
3.5	Transmission without acknowledge .....	13
<b>4</b>	<b>Software specification</b> .....	<b>15</b>
4.1	Interface protocol .....	15
4.2	Subaddress (receive mode) .....	15
4.3	Data bytes (detailed description) .....	16
<b>5</b>	<b>Package information</b> .....	<b>18</b>
<b>6</b>	<b>Revision history</b> .....	<b>19</b>

## List of tables

Table 1.	Device summary . . . . .	1
Table 2.	Absolute maximum ratings . . . . .	7
Table 3.	Quick reference data . . . . .	7
Table 4.	Thermal data . . . . .	7
Table 5.	Electrical characteristics . . . . .	8
Table 6.	Chip address . . . . .	15
Table 7.	Data bytes . . . . .	15
Table 8.	Volume . . . . .	16
Table 9.	Speaker attenuators . . . . .	16
Table 10.	Audio switch . . . . .	17
Table 11.	Bass and treble . . . . .	17
Table 12.	Document revision history . . . . .	19

## List of figures

Figure 1.	Block diagram . . . . .	5
Figure 2.	Test circuit . . . . .	6
Figure 3.	Pin connection (top view) . . . . .	6
Figure 4.	Loudness vs. volume attenuation . . . . .	10
Figure 5.	Loudness vs. frequency (CLOUD = 100 nF) vs. volume attenuation . . . . .	10
Figure 6.	Loudness vs. external capacitors . . . . .	10
Figure 7.	Noise vs. volume/gain setting . . . . .	10
Figure 8.	Signal to noise ratio vs. volume setting . . . . .	10
Figure 9.	Distortion and noise vs. frequency ( $V_{IN} = 1\text{ V}$ ) . . . . .	10
Figure 10.	Distortion and noise vs. frequency ( $V_{IN} = 250\text{ mV}$ ). . . . .	11
Figure 11.	Distortion vs. load resistance . . . . .	11
Figure 12.	Channel separation ( $L \text{ } \text{Æ} \text{ } R$ ) vs. frequency. . . . .	11
Figure 13.	Input separation ( $L1 \text{ } \text{Æ} \text{ } L2, L3$ ) vs. frequency. . . . .	11
Figure 14.	Supply voltage rejection vs. frequency . . . . .	11
Figure 15.	Output clipping level vs. supply voltage . . . . .	11
Figure 16.	Quiescent current vs. supply voltage . . . . .	12
Figure 17.	Supply current vs. temperature. . . . .	12
Figure 18.	Bass resistance vs. temperature . . . . .	12
Figure 19.	Typical tone response (with the external components indicated in the test circuit) . . . . .	12
Figure 20.	Data validity on the I <sup>2</sup> C bus . . . . .	14
Figure 21.	Timing diagram of S-bus and I <sup>2</sup> C bus. . . . .	14
Figure 22.	Acknowledge on the I <sup>2</sup> C bus . . . . .	14
Figure 23.	Interface protocol . . . . .	15
Figure 24.	SO-28 mechanical data and package dimensions . . . . .	18

# 1 Block, test and pin diagrams

## 1.1 Block diagram

Figure 1. Block diagram

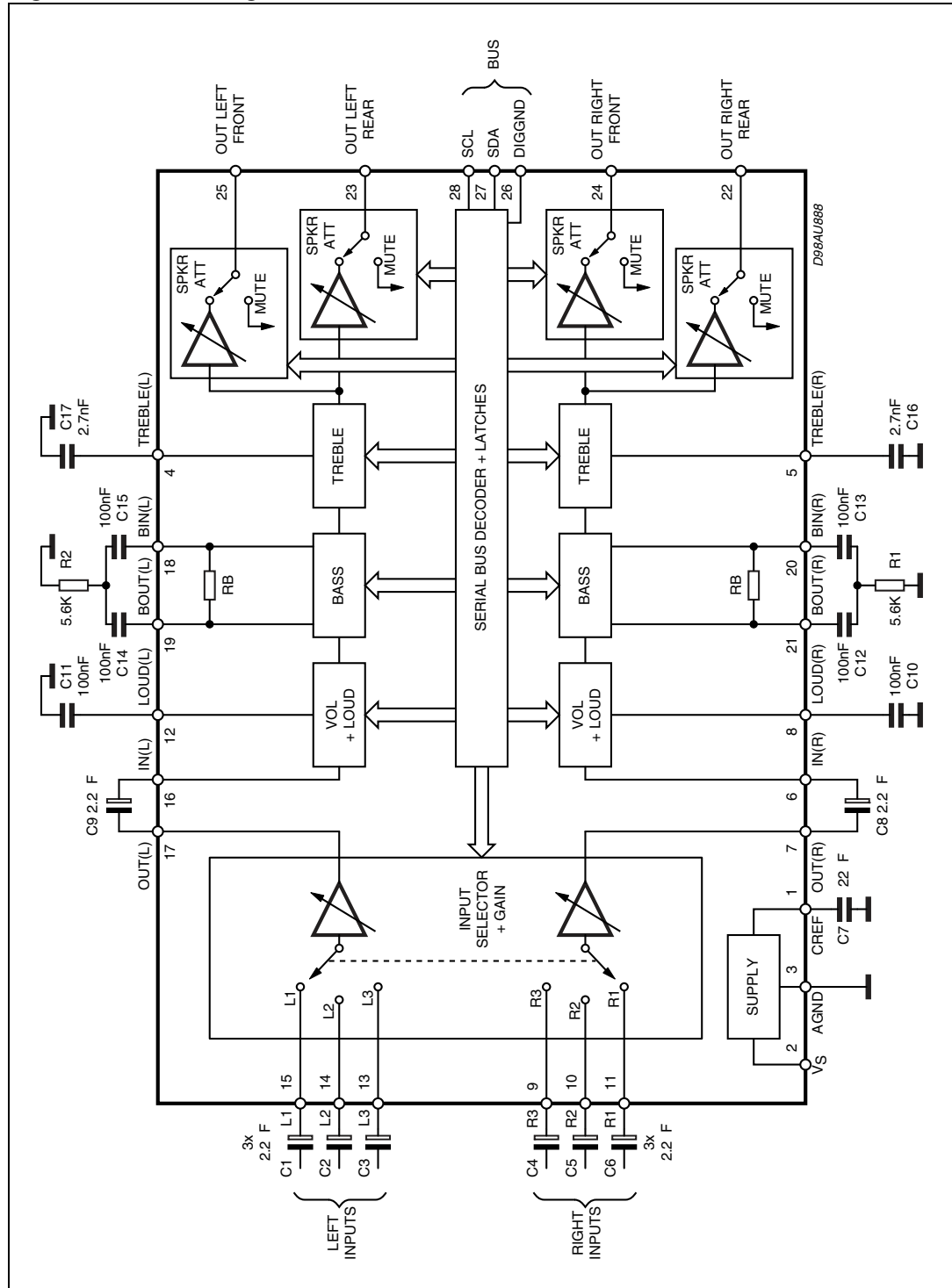

## 1.2 Test circuit

Figure 2. Test circuit

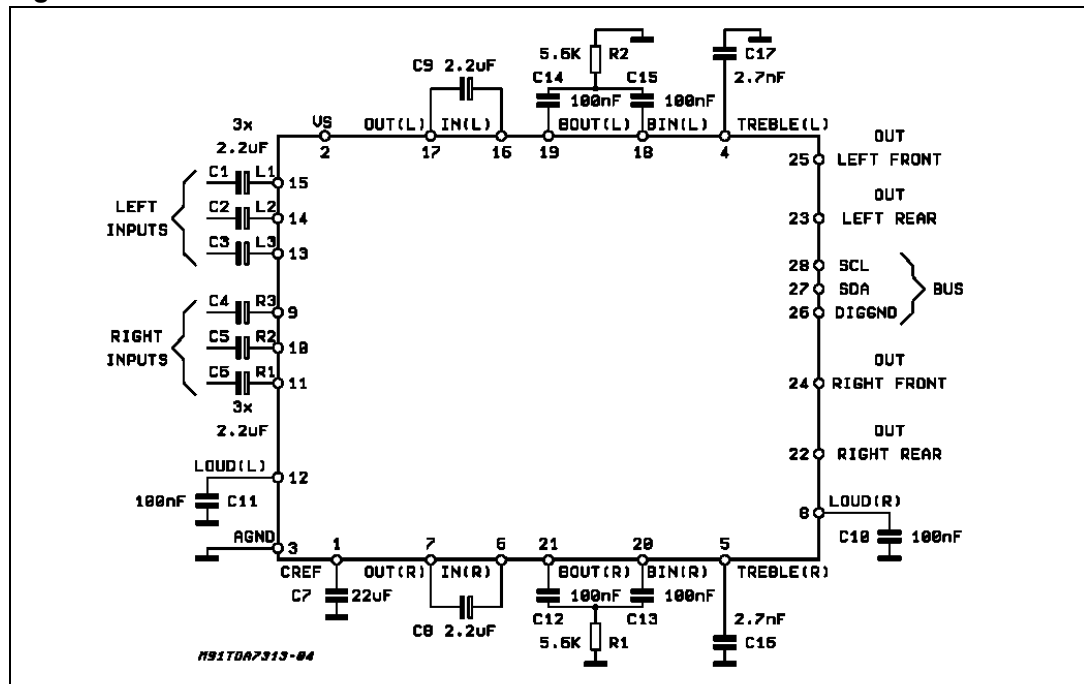

## 1.3 Pin connection

Figure 3. Pin connection (top view)

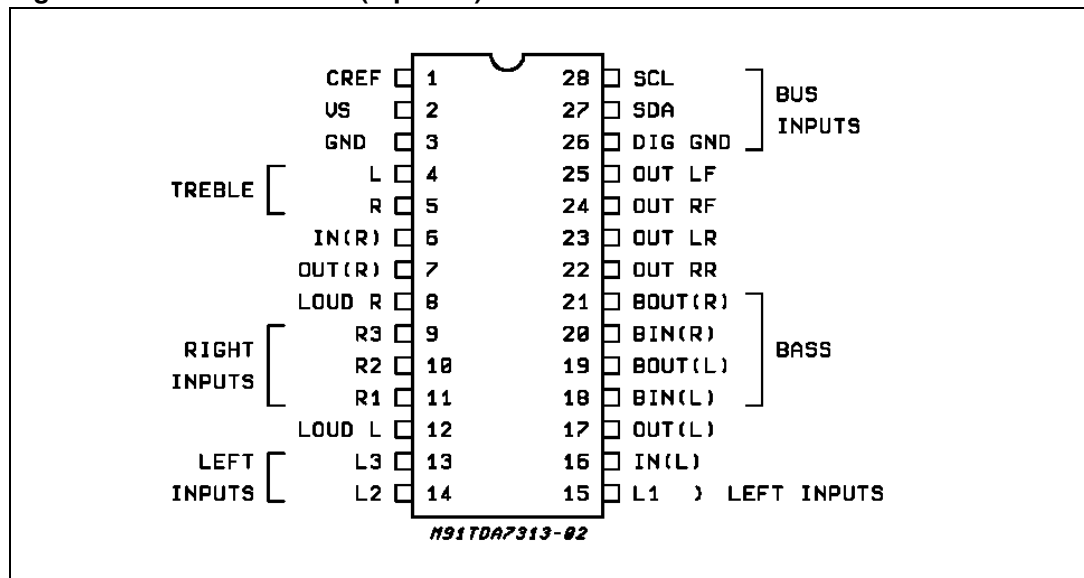

## 2 Electrical specifications

### 2.1 Absolute maximum ratings

Table 2. Absolute maximum ratings

Symbol	Parameter	Value	Unit
$V_S$	Operating supply voltage	10.0	V
$T_{amb}$	Ambient temperature	-40 to 85	°C
$T_{stg}$	Storage temperature range	-55 to +150	°C

### 2.2 Quick reference data

Table 3. Quick reference data

Symbol	Parameter	Min.	Typ.	Max.	Unit
$V_S$	Supply voltage	6	9	10	V
$V_{CL}$	Max. input signal handling	2			Vrms
THD	Total harmonic distortion $V = 1$ Vrms; $f = 1$ kHz		0.01		%
S/N	Signal to noise ratio		106		dB
$S_C$	Channel separation $f = 1$ kHz		103		dB
	Volume control 1.25d B step	-78.75		0	dB
	Bass and treble control 2 dB step	-14		+14	dB
	Fader and balance control 1.25 dB step	-38.75		0	dB
	Input gain 3.75 dB step 1.25 dB step	0		11.25	dB
	Mute attenuation		100		dB

### 2.3 Thermal data

Table 4. Thermal data

Symbol	Parameter	Value	Unit
$R_{th\ j-pins}$	Thermal resistance junction to pins	Max. 85	°C/W

## 2.4 Electrical characteristics

**Table 5. Electrical characteristics**  
 ( $T_{amb} = 25\text{ °C}$ ,  $V_S = 9\text{ V}$ ,  $R_L = 10\text{ k}\Omega$ ,  $R_G = 600\ \Omega$ , all control flat ( $G = 0$ ),  $f = 1\text{ kHz}$  unless otherwise specified)

Symbol	Parameter	Test condition	Min.	Typ.	Max.	Unit
<b>Supply</b>						
$V_S$	Supply voltage		6	9	10	V
$I_S$	Supply current			8	11	mA
SVR	Ripple rejection		60	80		dB
<b>Input selectors</b>						
$R_{II}$	Input resistance	Input 1, 2, 3, 4		50		k $\Omega$
$V_{CL}$	Clipping level		2	2.5		V <sub>rms</sub>
$S_{IN}$	Input separation <sup>(2)</sup>		80	100		dB
$R_L$	Output load resistance	pin 7, 17	2			k $\Omega$
$G_{INmin}$	Min. input gain		-1	0	1	dB
$G_{INmax}$	Max. input gain			11.25		dB
$G_{STEP}$	Step resolution			3.75		dB
$e_{IN}$	Input noise	$G = 11.25\text{ dB}$		2		$\mu\text{V}$
<b>Volume control</b>						
$R_{IN}$	Input resistance			33		k $\Omega$
$C_{RANGE}$	Control range		70	75	80	dB
$A_{VMIN}$	Min. attenuation		-1	0	1	dB
$A_{VMAX}$	Max. attenuation		70	75	80	dB
$A_{STEP}$	Step resolution		0.5	1.25	1.75	dB
$E_A$	Attenuation set error	$A_V = 0\text{ to }-20\text{ dB}$	-1.25	0	1.25	dB
		$A_V = -20\text{ to }-60\text{ dB}$	-3		2	dB
$E_T$	Tracking error				2	dB
<b>Speaker attenuators</b>						
$C_{range}$	Control range		35	37.5	40	dB
$S_{STEP}$	Step resolution		0.5	1.25	1.75	dB
$E_A$	Attenuation set error				1.5	dB
$A_{MUTE}$	Output mute attenuation		80	100		dB
<b>Bass control<sup>(1)</sup></b>						
$G_b$	Control range	Max. Boost/cut	$\pm 12$	$\pm 14$	$\pm 16$	dB
$B_{STEP}$	Step resolution		1	2	3	dB



**Table 5. Electrical characteristics (continued)**

( $T_{amb} = 25\text{ °C}$ ,  $V_S = 9\text{ V}$ ,  $R_L = 10\text{ k}\Omega$ ,  $R_G = 600\ \Omega$ , all control flat ( $G = 0$ ),  $f = 1\text{ kHz}$  unless otherwise specified)

Symbol	Parameter	Test condition	Min.	Typ.	Max.	Unit
$R_B$	Internal feedback resistance			44		$k\Omega$
<b>Treble control (1)</b>						
$G_t$	Control range	Max. Boost/cut	$\pm 13$	$\pm 14$	$\pm 15$	dB
$T_{STEP}$	Step Resolution		1	2	3	dB
<b>Audio outputs</b>						
$V_{OCL}$	Clipping level	$d = 0.3\%$	2	2.5		Vrms
$R_L$	Output load resistance		2			$k\Omega$
$C_L$	Output load capacitance				10	nF
$R_{OUT}$	Output resistance			75		$\Omega$
$V_{OUT}$	DC voltage level		4.2	4.5	4.8	V
<b>General</b>						
$e_{NO}$	Output noise <sup>(2)</sup>	BW = 20-20 kHz, flat output muted all gains = 0 dB		2.5 5		$\mu\text{V}$ $\mu\text{V}$
		A curve all gains = 0 dB		3		$\mu\text{V}$
S/N	Signal to noise ratio	all gains = 0 dB; $V_O = 1\text{ Vrms}$		106		dB
d	Distortion	$A_V = 0$ ; $V_{IN} = 1\text{ Vrms}$		0.01		%
		$A_V = -20\text{ dB}$ , $V_{IN} = 1\text{ Vrms}$		0.09	0.3	%
		$A_V = -20\text{ dB}$ , $V_{IN} = 0.3\text{ Vrms}$		0.04		%
$Sc$	Channel separation left/right		80	103		dB
	Total tracking error	$A_V = 0\text{ to }-20\text{ dB}$		0	1	dB
		-20 to -60 dB		0	2	dB
<b>Bus inputs</b>						
$V_{IL}$	Input low voltage				1	V
$V_{IH}$	Input high voltage		3			V
$I_{IN}$	Input current		-5		+5	$\mu\text{A}$
$V_O$	Output voltage SDA acknowledge	$I_O = 1.6\text{ mA}$			0.4	V

1. Bass and treble response see attached diagram (Figure 19). The center frequency and quality of the resonance behavior can be chosen by the external circuitry. A standard first order bass response can be realized by a standard feedback network
2. The selected input is grounded through the 2.2  $\mu\text{F}$  capacitor.

## 2.5 Electrical characteristics curves

Figure 4. Loudness vs. volume attenuation

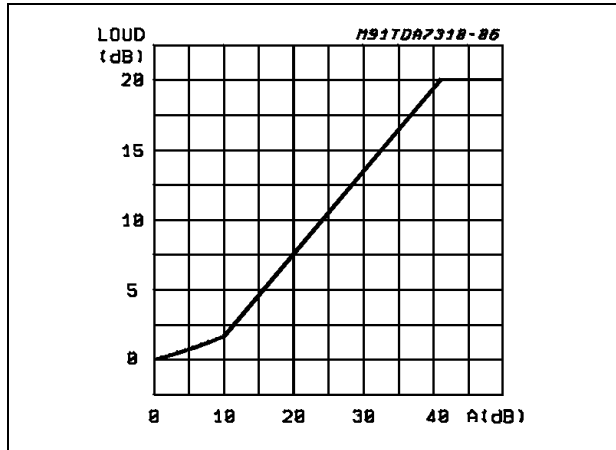

Figure 5. Loudness vs. frequency ( $C_{LOUD} = 100\text{ nF}$ ) vs. volume attenuation

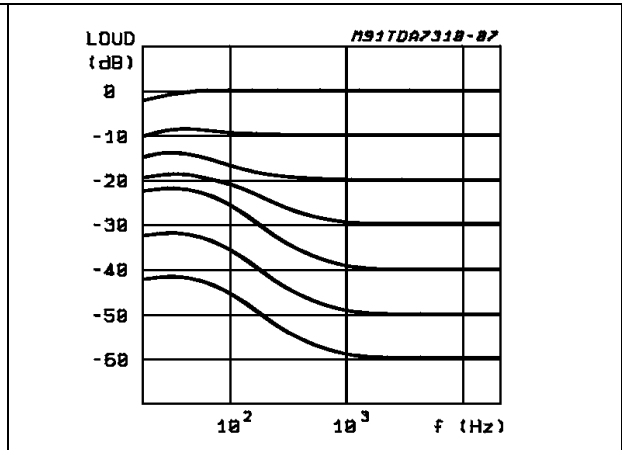

Figure 6. Loudness vs. external capacitors

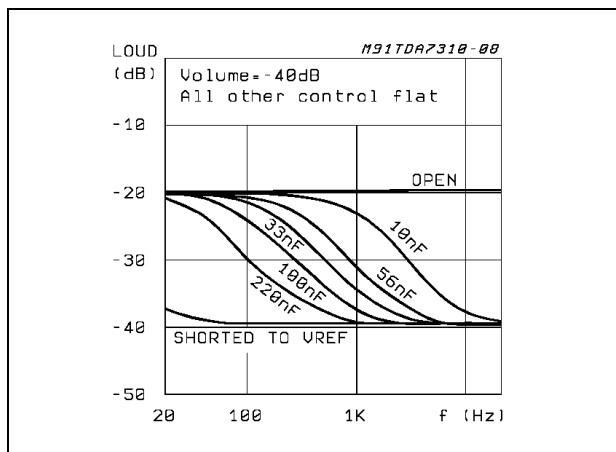

Figure 7. Noise vs. volume/gain setting

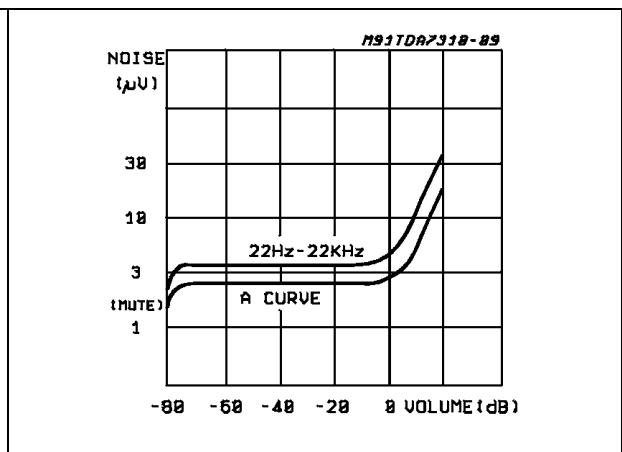

Figure 8. Signal to noise ratio vs. volume setting

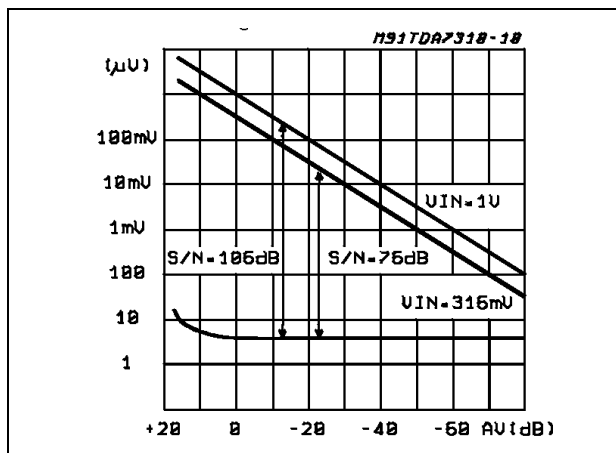

Figure 9. Distortion and noise vs. frequency ( $V_{IN} = 1\text{ V}$ )

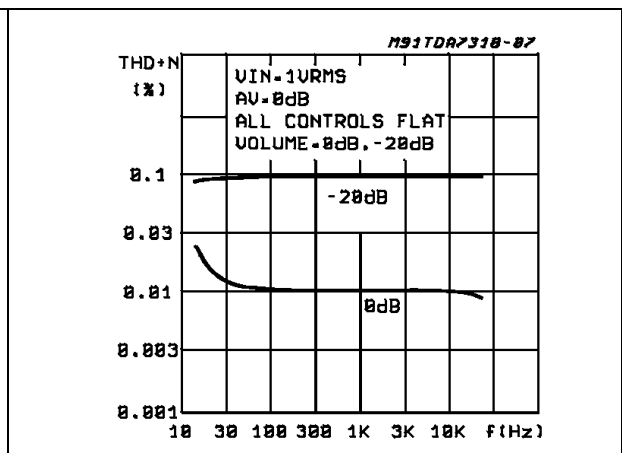

Figure 10. Distortion and noise vs. frequency ( $V_{IN} = 250\text{ mV}$ )

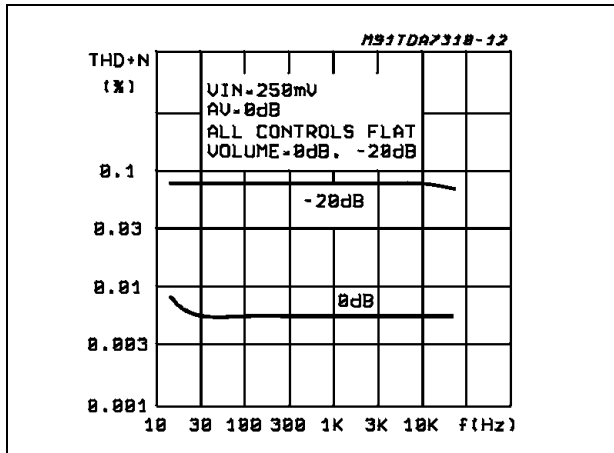

Figure 11. Distortion vs. load resistance

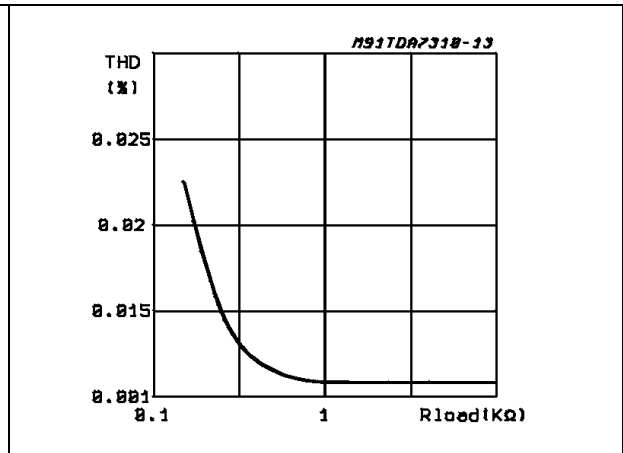

Figure 12. Channel separation (L → R) vs. frequency

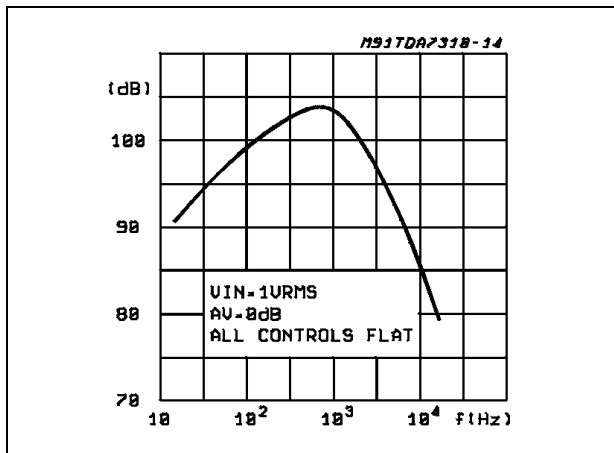

Figure 13. Input separation (L1 → L2, L3) vs. frequency

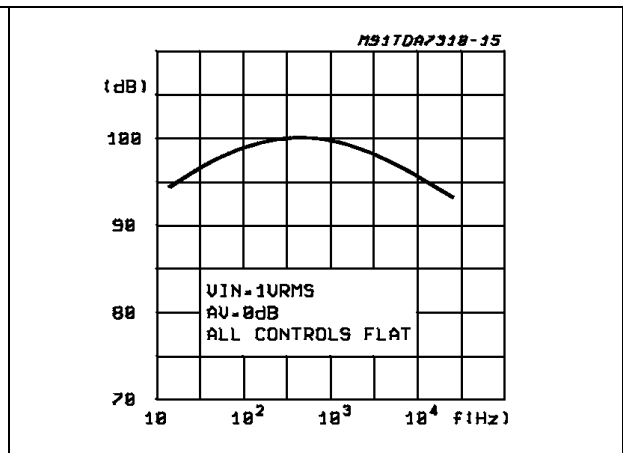

Figure 14. Supply voltage rejection vs. frequency

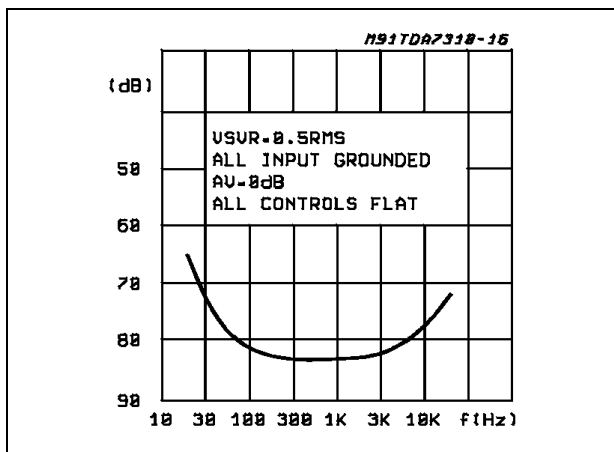

Figure 15. Output clipping level vs. supply voltage

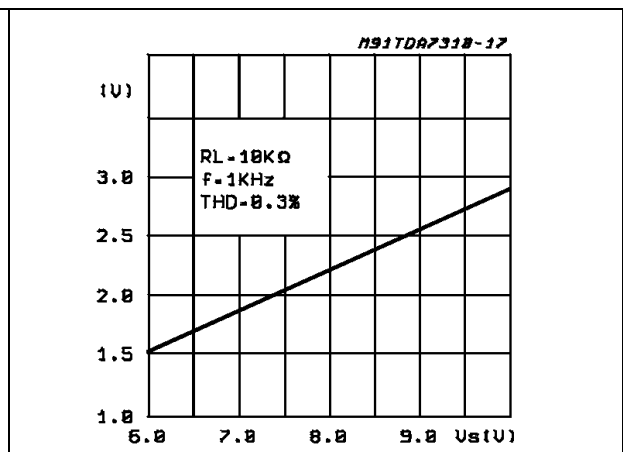

Figure 16. Quiescent current vs. supply voltage

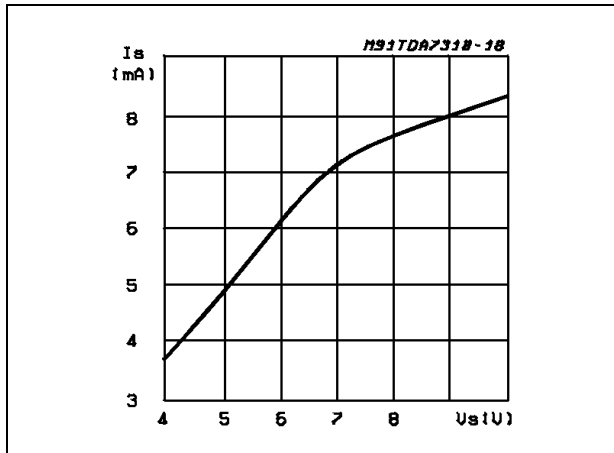

Figure 17. Supply current vs. temperature

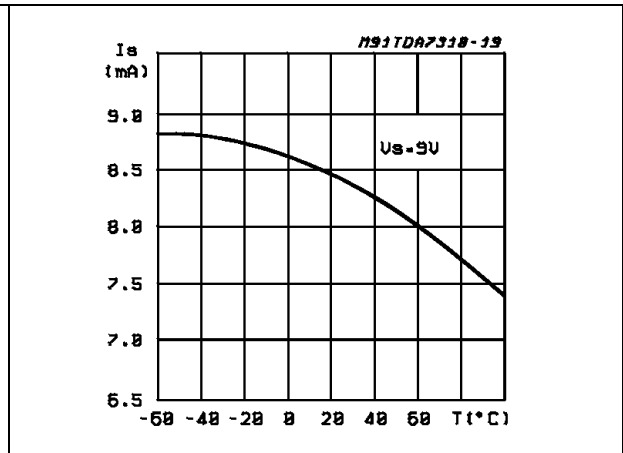

Figure 18. Bass resistance vs. temperature

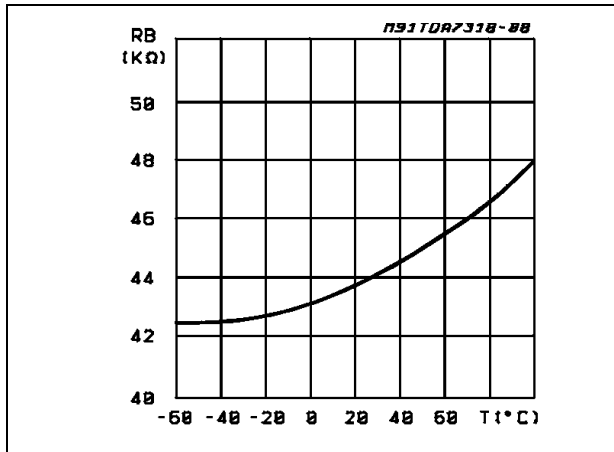
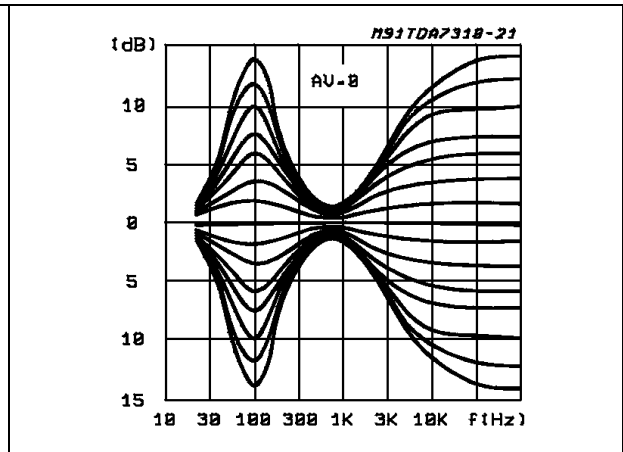

Figure 19. Typical tone response (with the external components indicated in the test circuit)



## 3 I<sup>2</sup>C bus interface

Data transmission from microprocessor to the TDA7303 and viceversa takes place through the 2 wires I<sup>2</sup>C bus interface, consisting of the two lines SDA and SCL (pull-up resistors to positive supply voltage must be connected).

### 3.1 Data validity

As shown in [Figure 20](#), the data on the SDA line must be stable during the high period of the clock. The high and low state of the data line can only change when the clock signal on the SCL line is IOW.

### 3.2 Start and stop conditions

As shown in [Figure 21](#) a start condition is a high to low transition of the SDA line while SCL is high. The stop condition is a low to high transition of the SDA line while SCL is high.

### 3.3 Byte format

Every byte transferred on the SDA line must contain 8 bits. Each byte must be followed by an acknowledge bit. The MSB is transferred first.

### 3.4 Acknowledge

The master ( $\mu$ P) puts a resistive HIGH level on the SDA line during the acknowledge clock pulse (see [Figure 22](#)). The peripheral (audioprocessor) that acknowledges has to pull-down (low) the SDA line during the acknowledge clock pulse, so that the SDA line is stable low during this clock pulse.

The audioprocessor which has been addressed has to generate an acknowledge after the reception of each byte, otherwise the SDA line remains at the high level during the ninth clock pulse time. In this case the master transmitter can generate the stop information in order to abort the transfer.

### 3.5 Transmission without acknowledge

Avoiding to detect the acknowledge of the audioprocessor, the  $\mu$ P can use a simpler transmission: simply it waits one clock without checking the slave acknowledging, and sends the new data.

This approach of course is less protected from misreading and decreases the noise immunity.

Figure 20. Data validity on the I<sup>2</sup>C bus

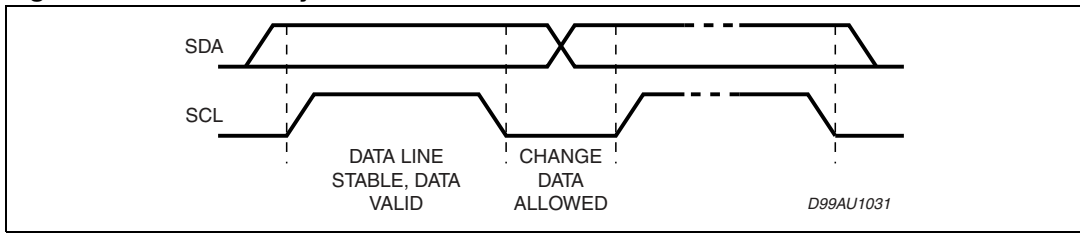

Figure 21. Timing diagram of S-bus and I<sup>2</sup>C bus

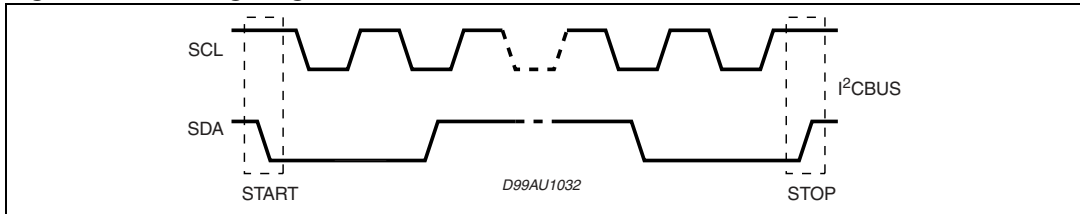
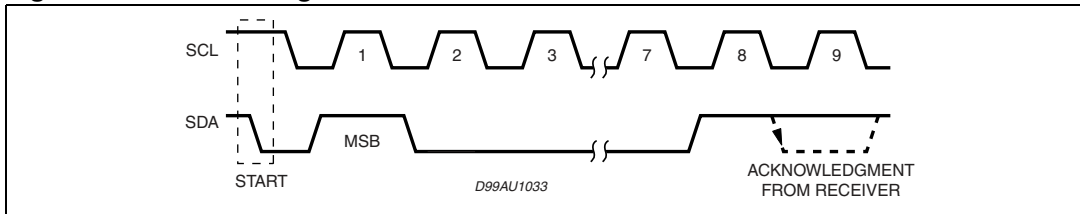

Figure 22. Acknowledge on the I<sup>2</sup>C bus



**Patent note:** Purchase of I<sup>2</sup>C Components of STMicroelectronics, conveys a license under the Philips I<sup>2</sup>C Patent Rights to use these components in an I<sup>2</sup>C system, provided that the system conforms to the I<sup>2</sup>C Standard Specifications as defined by Philips.

## 4 Software specification

### 4.1 Interface protocol

The interface protocol comprises:

- A start condition (s)
- A chip address byte, containing the TDA7303 address (the 8th bit of the byte must be 0).  
The TDA7303 must always acknowledge at the end of each transmitted byte.
- A sequence of data (N-bytes + acknowledge)
- A stop condition (P)

**Figure 23. Interface protocol**

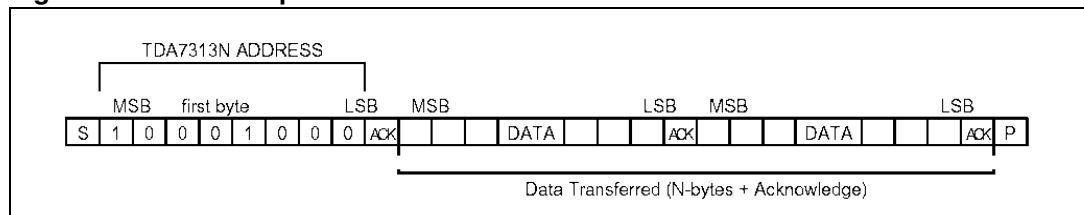

ACK = Acknowledge

S = Start

P = Stop

Max. clock speed 400 kbits/s

### 4.2 Subaddress (receive mode)

**Table 6. Chip address**

MSB							LSB
1	0	0	0	1	0	0	0

**Table 7. Data bytes**

MSB					LSB			Function
0	0	B2	B1	B0	A2	A1	A0	Volume control
1	1	0	B1	B0	A2	A1	A0	Speaker ATT LR
1	1	1	B1	B0	A2	A1	A0	Speaker ATT RR
1	0	0	B1	B0	A2	A1	A0	Speaker ATT LF
1	0	1	B1	B0	A2	A1	A0	Speaker ATT RF
0	1	0	G1	G0	S2	S1	S0	Audio switch
0	1	1	0	C3	C2	C1	C0	Bass control
0	1	1	1	C3	C2	C1	C0	Treble control

Ax = 1.25dB steps; Bx = 10dB steps; Cx = 2dB steps; Gx = 3.75dB steps

### 4.3 Data bytes (detailed description)

Table 8. Volume

MSB					LSB			Function
0	0	B2	B1	B0	A2	A1	A0	Volume 1.25 dB steps
					0	0	0	0
					0	0	1	-1.25
					0	1	0	-2.5
					0	1	1	-3.75
					1	0	0	-5
					1	0	1	-6.25
					1	1	0	-7.5
					1	1	1	-8.75
								<b>Volume 10 dB steps</b>
		0	0	0				0
		0	0	1				-10
		0	1	0				-20
		0	1	1				-30
		1	0	0				-40
		1	0	1				-50
		1	1	0				-60
		1	1	1				-70

For example a volume of -45 dB is given by: 0 0 1 0 0 1 0 0

Table 9. Speaker attenuators

MSB					LSB			Function
1	0	0	B1	B0	A2	A1	A0	Speaker LF
1	0	1	B1	B0	A2	A1	A0	Speaker RF
1	1	0	B1	B0	A2	A1	A0	Speaker LR
1	1	1	B1	B0	A2	A1	A0	Speaker RR
					0	0	0	0
					0	0	1	-1.25
					0	1	0	-2.5
					0	1	1	-3.75
					1	0	0	-5
					1	0	1	-6.25
					1	1	0	-7.5
					1	1	1	-8.75
			0	0				0
			0	1				-10
			1	0				-20
			1	1				-30
			1	1	1	1	1	Mute

For example attenuation of 25 dB on speaker RF is given by: 1 0 1 1 0 1 0 0



Table 10. Audio switch

MSB				LSB				Function
0	1	0	G1	G0	S2	S1	S0	Audio Switch
						0	0	Stereo 1
						0	1	Stereo 2
						1	0	Stereo 3
						1	1	Not allowed
					0			Loudness ON
					1			Loudness OFF
			0	0				+11.25 dB
			0	1				+7.5 dB
			1	0				+3.75d B
			1	1				0 dB

For example to select the stereo 2 input with a gain of +7.5dB LOUDNESS ON the 8bit string is: 0 1 0 0 1 0 0 1

Table 11. Bass and treble

MSB				LSB				Function
0	1	1	0	C3	C2	C1	C0	Bass
0	1	1	1	C3	C2	C1	C0	Treble
				0	0	0	0	-14
				0	0	0	1	-12
				0	0	1	0	-10
				0	0	1	1	-8
				0	1	0	0	-6
				0	1	0	1	-4
				0	1	1	0	-2
				0	1	1	1	0
				1	1	1	1	0
				1	1	1	0	2
				1	1	0	1	4
				1	1	0	0	6
				1	0	1	1	8
				1	0	1	0	10
				1	0	0	1	12
				1	0	0	0	14

C3 = Sign

For example Bass at -10dB is obtained by the following 8 bit string: 0 1 1 0 0 0 1 0

## 5 Package information

In order to meet environmental requirements, ST offers these devices in different grades of ECOPACK® packages, depending on their level of environmental compliance. ECOPACK® specifications, grade definitions and product status are available at: [www.st.com](http://www.st.com).

ECOPACK® is an ST trademark.

**Figure 24. SO-28 mechanical data and package dimensions**

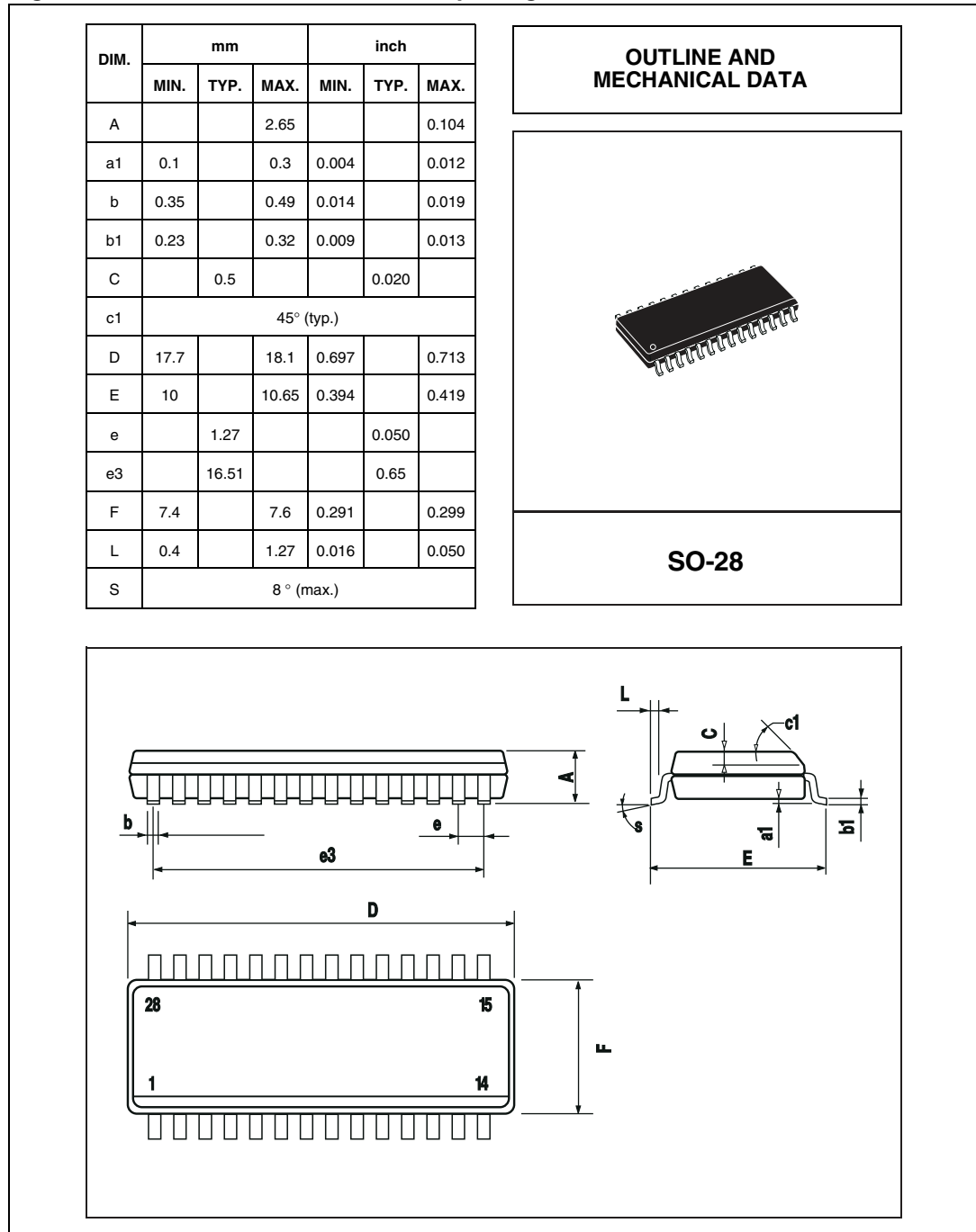

## 6 Revision history

**Table 12. Document revision history**

Date	Revision	Changes
04-Aug-2006	1	Initial release.
13-Mar-2009	2	Updated “distortion” parameter in the <a href="#">Table 5: Electrical characteristics</a> on the page 9. Modified the max. clock speed value in <a href="#">Section 4.1: Interface protocol on page 15</a> . Updated <a href="#">Section 5: Package information on page 18</a> .
18-Mar-2009	3	Modified the test condition of the parameter “distortion” in the <a href="#">Table 5: Electrical characteristics</a> on the page 9.
17-Sep-2013	4	Updated Disclaimer

**Please Read Carefully:**

Information in this document is provided solely in connection with ST products. STMicroelectronics NV and its subsidiaries ("ST") reserve the right to make changes, corrections, modifications or improvements, to this document, and the products and services described herein at any time, without notice.

All ST products are sold pursuant to ST's terms and conditions of sale.

Purchasers are solely responsible for the choice, selection and use of the ST products and services described herein, and ST assumes no liability whatsoever relating to the choice, selection or use of the ST products and services described herein.

No license, express or implied, by estoppel or otherwise, to any intellectual property rights is granted under this document. If any part of this document refers to any third party products or services it shall not be deemed a license grant by ST for the use of such third party products or services, or any intellectual property contained therein or considered as a warranty covering the use in any manner whatsoever of such third party products or services or any intellectual property contained therein.

**UNLESS OTHERWISE SET FORTH IN ST'S TERMS AND CONDITIONS OF SALE ST DISCLAIMS ANY EXPRESS OR IMPLIED WARRANTY WITH RESPECT TO THE USE AND/OR SALE OF ST PRODUCTS INCLUDING WITHOUT LIMITATION IMPLIED WARRANTIES OF MERCHANTABILITY, FITNESS FOR A PARTICULAR PURPOSE (AND THEIR EQUIVALENTS UNDER THE LAWS OF ANY JURISDICTION), OR INFRINGEMENT OF ANY PATENT, COPYRIGHT OR OTHER INTELLECTUAL PROPERTY RIGHT.**

**ST PRODUCTS ARE NOT DESIGNED OR AUTHORIZED FOR USE IN: (A) SAFETY CRITICAL APPLICATIONS SUCH AS LIFE SUPPORTING, ACTIVE IMPLANTED DEVICES OR SYSTEMS WITH PRODUCT FUNCTIONAL SAFETY REQUIREMENTS; (B) AERONAUTIC APPLICATIONS; (C) AUTOMOTIVE APPLICATIONS OR ENVIRONMENTS, AND/OR (D) AEROSPACE APPLICATIONS OR ENVIRONMENTS. WHERE ST PRODUCTS ARE NOT DESIGNED FOR SUCH USE, THE PURCHASER SHALL USE PRODUCTS AT PURCHASER'S SOLE RISK, EVEN IF ST HAS BEEN INFORMED IN WRITING OF SUCH USAGE, UNLESS A PRODUCT IS EXPRESSLY DESIGNATED BY ST AS BEING INTENDED FOR "AUTOMOTIVE, AUTOMOTIVE SAFETY OR MEDICAL" INDUSTRY DOMAINS ACCORDING TO ST PRODUCT DESIGN SPECIFICATIONS. PRODUCTS FORMALLY ESCC, QML OR JAN QUALIFIED ARE DEEMED SUITABLE FOR USE IN AEROSPACE BY THE CORRESPONDING GOVERNMENTAL AGENCY.**

Resale of ST products with provisions different from the statements and/or technical features set forth in this document shall immediately void any warranty granted by ST for the ST product or service described herein and shall not create or extend in any manner whatsoever, any liability of ST.

ST and the ST logo are trademarks or registered trademarks of ST in various countries.

Information in this document supersedes and replaces all information previously supplied.

The ST logo is a registered trademark of STMicroelectronics. All other names are the property of their respective owners.

© 2013 STMicroelectronics - All rights reserved

STMicroelectronics group of companies

Australia - Belgium - Brazil - Canada - China - Czech Republic - Finland - France - Germany - Hong Kong - India - Israel - Italy - Japan - Malaysia - Malta - Morocco - Philippines - Singapore - Spain - Sweden - Switzerland - United Kingdom - United States of America

[www.st.com](http://www.st.com)