



## AL-DALI-HAT-I

Raspberry Pi to DALI  
Co-Processor

with either:

2 Isolated Busses

or

4 Isolated Busses

v14 firmware

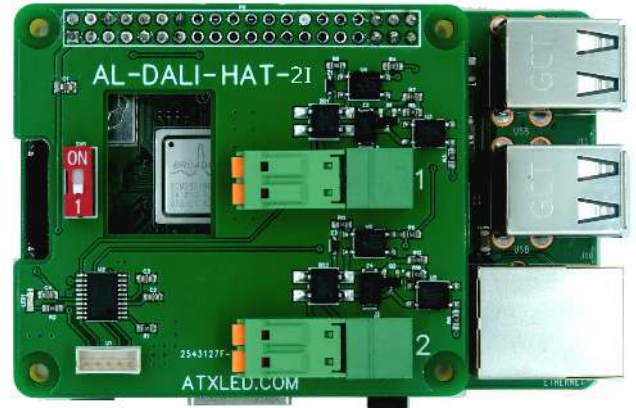

### [Product Description - AL-DALI-HAT-I2 or I4](#)

This device interconnects a Raspberry Pi with 2 (or 4) DALI busses. Using your own software or our ZWD application (not included) – you can now control up to 256 addressable light fixtures from a Raspberry Pi.

Included in the AL-DALI-HAT-I2 (I4) are the following key functions

- DALI hardware interface
- Real Time co-processor to offload the DALI bus hardware interface
- Serial port to the Raspberry Pi
- DALI bus status reporting
- Autonomous Bus to Bus forwarding

### [Overview](#)

The Raspberry Pi uses the on-board serial port to communicate at 19200 baud to the DALI HAT-I, this rate is 16 times faster than the DALI bus – the hardware on the HAT-I2 (I4) adapts the UART serial data stream into DALI encoding. The Pi can read and write the DALI bus at it's leisure, the co-processor on the HAT-I2 (I4) handles all real-time functions.

# Wiring Connections

## Power for the AL-DALI-HAT-I

Connect the AL-DALI-HAT-I2 or AL-DALI-HAT-I4 to the Raspberry Pi. Apply power to the Raspberry Pi.

## DALI bus connection

Connect a pair of DA pins to your DALI bus. You will need an external DALI power supply. The DALI bus must have a current limit ( typically 260 mA and 16 volt max ) for normal operation. The 2 (4) busses are opto isolated from the DALI Pi itself.

## Software Switch

The HAT has an onboard switch that can be used for any software defined function. At default it is used to select the bus current at power up. This bus current control can be disabled by software. Using the Q command – the switch function can be disconnected from the DALI power calculation and become useful for any software function.

## Raspberry Serial port setup

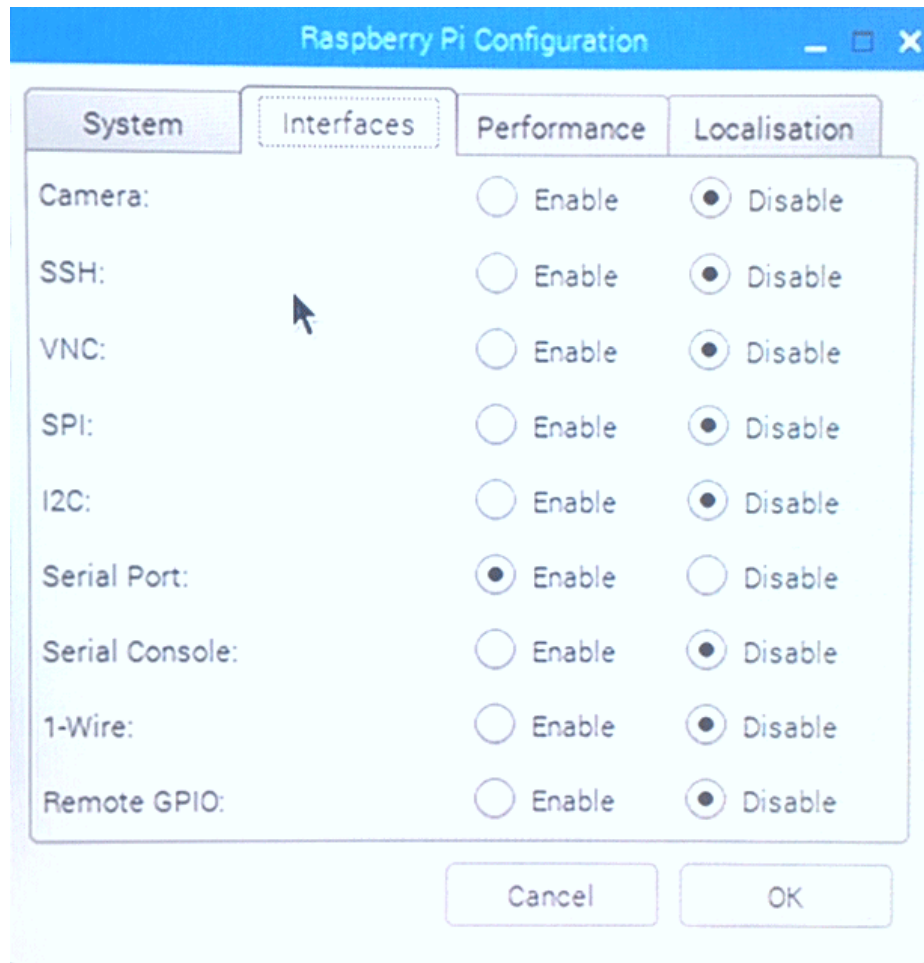

## DALI commands from the Pi to the HAT

Command	Length	Command type	
h	4	16 bit DALI	The AL-DALI-HAT-I2 (I4) receives serial port strings from Pi and forwards them to the DALI bus. The packet is 2, 4, 6 or 8 bytes long and begins with one of these characters. We send lower case, and receive upper case: Length is the number of characters after the command
t	4	16 bit DALI – sent twice	
j	2	8 bit DALI	
l	6	24 bit DALI	
m	8	25 bit DALI	
d	0	Query DALI bus	On receipt, the AL-DALI-HAT-I2 (I4) will wait for the DALI bus to be non busy, then will transmit the command. In the case of the t command – it will send the data twice within 100 ms.
f	10	Set forwarding table (v14)	
p	0	Query power and switch Info	
v	0	Query Version	
	0	Query String	
s	< 59	Store up to 59 characters	

## Simple Serial I/O examples

See <https://atxled.com/Pi> for python code samples. Some DALI lighting control examples from Pi to Pi HAT-I2 (I4) to DALI bus are shown here

Function	Decimal command	Send to HAT	Response
All lights on full – bus 2	254 254	1hFEFE	None
All lights off – bus 3	254 0	2hFE00	None
Initialize – bus 4	165 0	3tA500	None
Query status of #4 – bus 2	9 144	1h0990	6
Set #5 to 200 – bus 2	10 200	1H0AC8	None

See <https://atxled.com/pdf/AL-WS-DR2.pdf> for a list of commands, see the wikipedia article on DALI lighting for the addressing format for DALI.

## Bus Selection

Bus number	DALI all On command	DALI response
1	HFEFE	N
2	1HFEFE	1N
3	2HFEFE	2N
4	3HFEFE	3N

## Specifications

Name	Function	Description
	Internal Power consumption	50 milliwatt ( plus the Pi )
DA	DALI Bus	2 ( or 4 ) DALI Busses, opto isolated,
Power	Interface to Pi	Ground ( pins 6, 9, 14, 20, 25, 30, 34, 39) 3.3 Volts from the Pi ( 20 mA ) ( pin 1 )
Serial IP	Interface to Pi	Serial Tx and Rx ( pins 8, 10)
	Operating Temperature	0°C ~ 50°C
	Size	75 mm x 55 mm x 27 mm

## Autonomous Features

At all times – the AL-DALI-HAT-I2 (I4) is listening to the DALI bus. Some DALI bus packets will be processed internally by the Hat – others are passed to the Pi without processing.

The packets that are processed internally are

- DTR commands – those packets received that set values into the DTR will cause the Pi to not broadcast any packets for 200 ms. This allows a multi byte bus sequence to be completed without interruptions
- Inter-channel forwarding.

## Inter Channel Forwarding

The HAT has a 32 entry table of bus to bus forwarding which is handled by the Hat itself, without requiring the Pi to handle. An ARC, DALI Off, Read Level or Scene command received on a “source” bus, if matched in the table, will be forwarded to the Pi and to a destination address on a destination channel. Destination device levels will be wrong at power up and after scene recall, and are updated by ARC commands that occur on the destination bus normally.

Programming the forwarding table is done as follows, the table is stored in flash memory for use at power up:

- Send a Fxx command ( example F00) to read back the forwarding table entry 0. There are 32 entries response is Fxxssaaddaa
- Send a Fxxssaaddaa packet to create an entry with these values:
  - xx table entry # 0-31
  - ss monitored bus number 0-3, dd is destination bus number 0-3
  - aa address ( 0-63 is address, 64-79 is group 0-15, 80-95 is trigger 0-15, 208-223 is scene 0-15)
  - if the destination bus is 128 + Bus# ( 128- 131), then packets traverse in both directions.

Trigger is source DALI 0xBFxy. If y matches, then forward either a) the trigger 0-127 or b) a scene 0-15 set destination address < 128 for destination as trigger, and 208-223 for destination as a scene

## DALI monitoring – packets to the Pi

At all times – the AL-DALI-HAT-I2 (I4) is listening to the DALI bus. Any commands on the bus will be forwarded to the Pi for recording the state of the DALI bus. The packets sent to the Pi are. If there is no response after 100 ms to a packet, then a collision has occurred.

Header to Pi	Structure	Xx	yy	cc	zz
B Boot	Bxyycc	HW Version	FW Version	Switch	
H DALI 16 bit	Hxyy	DALI byte 0	DALI byte 1		
F Forwarding	See Forwarding				
J DALI 8 bit	Jxx	DALI byte			
L DALI 24 bit	Lxyycc	DALI byte 0	DALI byte 1	DALI byte 2	
M DALI 25 bit	Mxyycczz	DALI byte 0	DALI byte 1	DALI byte 2	DALI byte 3
N No Response	N				
P Power Status	Pxyyzz	0	0	Switch on/off	
Q Query	Q	N/A			
S Key Storage	S	See Key storage			
V Version	Vxyycc	HW Version	FW Version	Switch	
X Collision on Receive	Xx				
Z Collision on Transmit	Zxx				
Other Collision	Null response				

A "zDxc" packet is sent proactively by the HAT to the Pi on any change in the bus status, or in response to a 'd' query

D	Z	x	C
zDxc = status response	Channel 0-3	DALI bus power status 0 = No DALI Bus power 1 = DALI bus short to plus 2 = OK	# of channels (1, 2 or 4)

## DALI reporting sent to the Pi

At all times – the AL-DALI-HAT is listening to the DALI bus. Any commands on the bus will be forwarded to the Pi for recording the state of the DALI bus. Also status changes are sent.

The packets sent to the Pi start with a Capital Letter followed by values without commas:

- B means reboot, followed by 6 characters, HW version (2), SW version (2), channel count (2). This device has 1 channel
- D means DALI bus power supply status, 2 characters follow ( one byte with status, then one byte = one channel => 1)
- H means receipt of a 16 bit DALI packet, 4 Hex characters follow
- J means receipt of an 8 bit DALI packet, 2 Hex characters follow
- L means receipt of a 24 bit DALI packet, 6 Hex characters follow
- N means no response received – normal in most cases ( DALI NAK )
- M means receipt of a 25 bit DALI packet, 8 Hex characters follow ( fw 18 or later)
- P is for switch 0000 plus the onboard switch status, 7 characters
- S is the String stored in EEPROM ( bytes 1-30 )
- T is the String stored in EEPROM if longer than 30 bytes( bytes 31-59)
- V same values as B
- X means bus collision on Receive– normal in most cases
- Z means bus collision on Transmit– normal in most cases

The DALI power supply state is also sent proactively by the HAT if the DALI bus changes readiness

- D01 = no power on DALI , one channel
- D11 = Bus current too high – cannot drive to zero, one channel
- D21 = DALI bus OK, one channel

The HAT version status info is encoded as (Vxxyyzz) ( V is replaced by B when the HAT restarts)

- xx = Hardware Version
- yy = Firmware Version ( decimal = 32 is 32 not 50 )
- 01 = Hardware Type ( see the wiki for Hardware types )

The HAT status info is encoded as ( Pxxyyzz)

- 000000
- z = 0 or 1 for the Switch On/Off status

Collisions on the DALI bus are expected during address search, but there are cases that are not expected. Check for lower than specified DALI bus voltages, higher currents than specified, or longer line lengths, the AL-DALI-Hat reports these errors.

- X4 = packet length error
- X3 = short bit received
- X2 = multiple packets received
- Z = Collision on transmit – normal, command should be resent
- null response = same as X Collision

## DALI Command Structure

DALI commands for simple applications are 2 byte commands with either a 1 byte response or no response. The Wikipedia article offers a good explanation.

The 2 bytes of each basic command can be of these these types

- A) Simple Direct Light Level commands
- B) Complex commands for immediate action
- C) Complex commands requiring the command to be repeated once in 100 ms for action
- D) Complex commands using previously stored information

There are 3 types of addressing methods for these commands

- 1) Broadcast – all device receive the same information
- 2) Unicast – only one device receives the information
- 3) Group – only the devices in the group receive the information.

There are 64 individual addresses, 16 group addresses, one broadcast. The individual and group addresses are shift one bit left for transmission.

The AL-DALI-HAT-I2 (I4) accepts Hex commands to pass thru to the DALI bus. So Hex 2 is address one. The commands listed in the AL-WS-DR2, AL-WS-010v, and PWS-POE-DALI are listed in Decimal – please convert to hex. In Hex – the format is

Target	Direct Light Control	Complex Commands
Broadcast	FExx where xx is the light level	FFxx where xx is the command 0 thru 255
Individual	00 thru 7E ( address times 2 )	yyxx where yy is 01 thru 7F ( addr x 2 + 1 ) xx is a command from 0 thru 255
Group	80 thru 9E ( group times 2 + 128)	yyxx where yy is 81 thru 9F (group x 2 + 1) xx is a command from 0 thru 255
Broadcast		A1xx thru BFxx – commands 256 thru 271 xx is the data to the device
Broadcast		C1xx thru DFxx – commands 272 thru 287 xx is the data to the device

The DALI devices have up to 3 internal registers called DTR, DTR1 and DTR2.

Many complex commands require that the DTR register be written first, then the command is given. For example – setting the Maximum dimming level requires first a number be stored in DTR, then the DTR is stored into the device. AL-DALI-HAT-I2 (I4) accepts Hex commands to pass thru to the DALI bus. For example, setting device 5 to max level 240 ( the range is 0 thru 254) the commands are

- a) A3F0 – save 240 into the DTR in all devices ( broadcast)
- b) 0B2A – save DTR as max value only to device address 5 ( times 2 plus 1 == B)

So Hex 0A is address five direct control and 0B is address five complex commands. The commands listed in the AL-WS-DR2, AL-WS-010v, and PWS-POE-DALI are listed in decimal – please convert to hex.

# ATX LED ZWD Application

The ZWD package for the Raspberry Pi creates a complete DALI master with all features needed for configuration and management of a DALI system. It includes interfaces to Alexa, Google, Hue, Homebridge, Smarthings, Siri and so on.

The image displays four screenshots of the ATX LED ZWD application interface:

- Top Left:** A sidebar menu with options: DALI Devices, Other DALI, Groups, Scenes, Schedule, Triggers, DMX Groups, Hue, Admin (highlighted), Support, WiFi Setup, DALI Log, Advanced, ZWave, and ZWave Logs. The main content area shows the 'Status' page with fields for Site Name, email address, and dateplicity.
- Top Right:** A 'Query DALI Power Status' page showing a grid of 63 DALI power status indicators (0-62) and a control panel with buttons for On, Up, Down, Min, Max, On and Stop Up, Stop Down and Off, and a scene selection dropdown.
- Bottom Left:** A 'DALI Devices' configuration page for device 'DR2G 2x6'. It shows configuration options like Edit name, Hue name, Fade Time, and Fade Rate, along with a status section showing Channel, Short address, Model ID, etc.
- Bottom Right:** A 'Schedule' page showing a list of entries like 'DR2F Warm' and 'DR2F cool' with options to edit, delete, or trigger them. A 'New Entry' form is also visible.



# DALI bus products from ATX LED Consultants

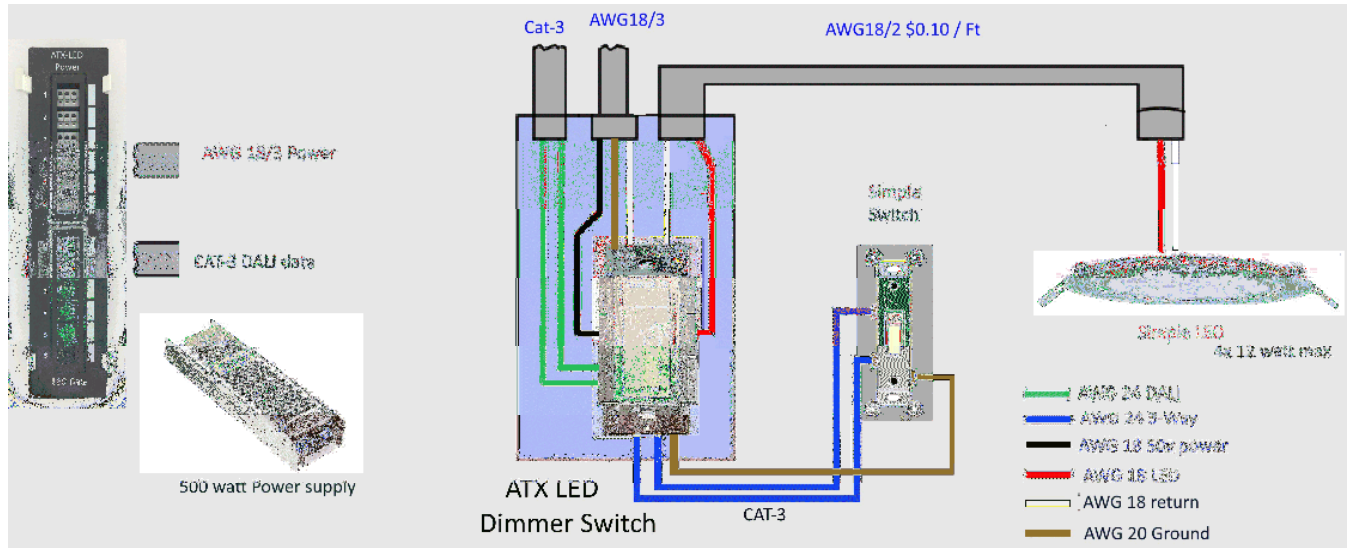

## Low Voltage house lighting product line

