

P	LTR	DESCRIPTION	DATE	DWN	APVD
0		REVISED PER EC 0K40-0124-04	03JUN2004	AH	MPT
P		REVISED PER PCN-22-147458	21JUL2022	SN	FC

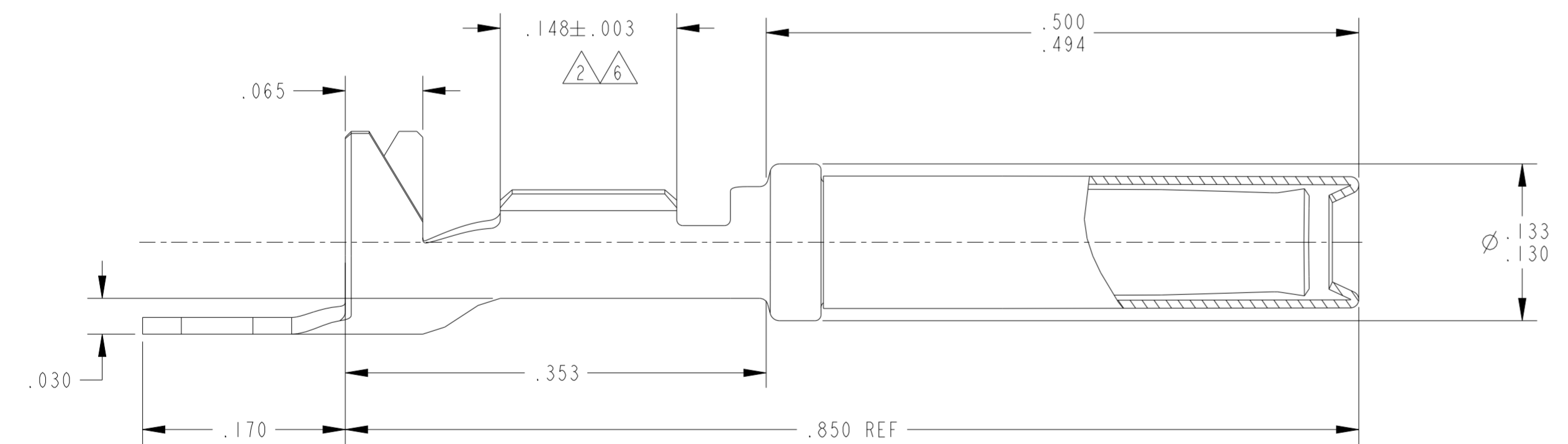

- 1 MATERIAL:
BODY: .014 THK. COPPER ALLOY.
SLEEVE: .007 THK. STAINLESS STEEL
- 2 FINISH:
BODY: .000030 MIN SELECT GOLD IN LOCALIZED GOLD PLATE AREA, AND .000100-.000200 TIN IN LOCALIZED TIN PLATE AREA.
ALL OVER: .000040-.000080 THK. NICKEL.
SLEEVE: PASSIVATE PER 112-230-2, METHOD 1.
- 3. CONTACT TO BE LUBED WITH LUBRICANT PER AMP P/N 22014-4.
- 4. WIRE RANGE: 20-18 AWG WITH INSULATION DIAMETERS OF .089 - .131 INCHES.
- 5. SLEEVE MUST WITHSTAND PULL OFF FORCE IN DIRECTION PARALLEL TO CENTRE OF TERMINAL OF 10 LBS MINIMUM.
- 6 MATERIAL:
BODY: .000100 - .000200 TIN IN LOCALIZED TIN PLATE AREA.
ALL OVER: .000040 - .000080 THK NICKEL.
SLEEVE: PASSIVATE PER 112-230-2, METHOD 1.

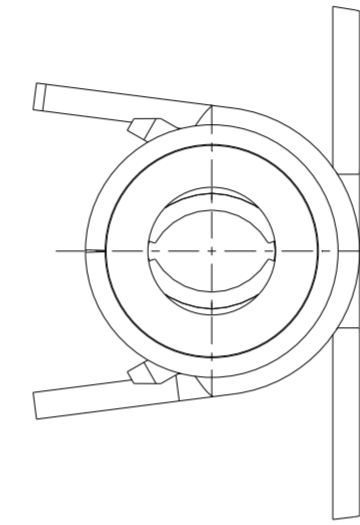
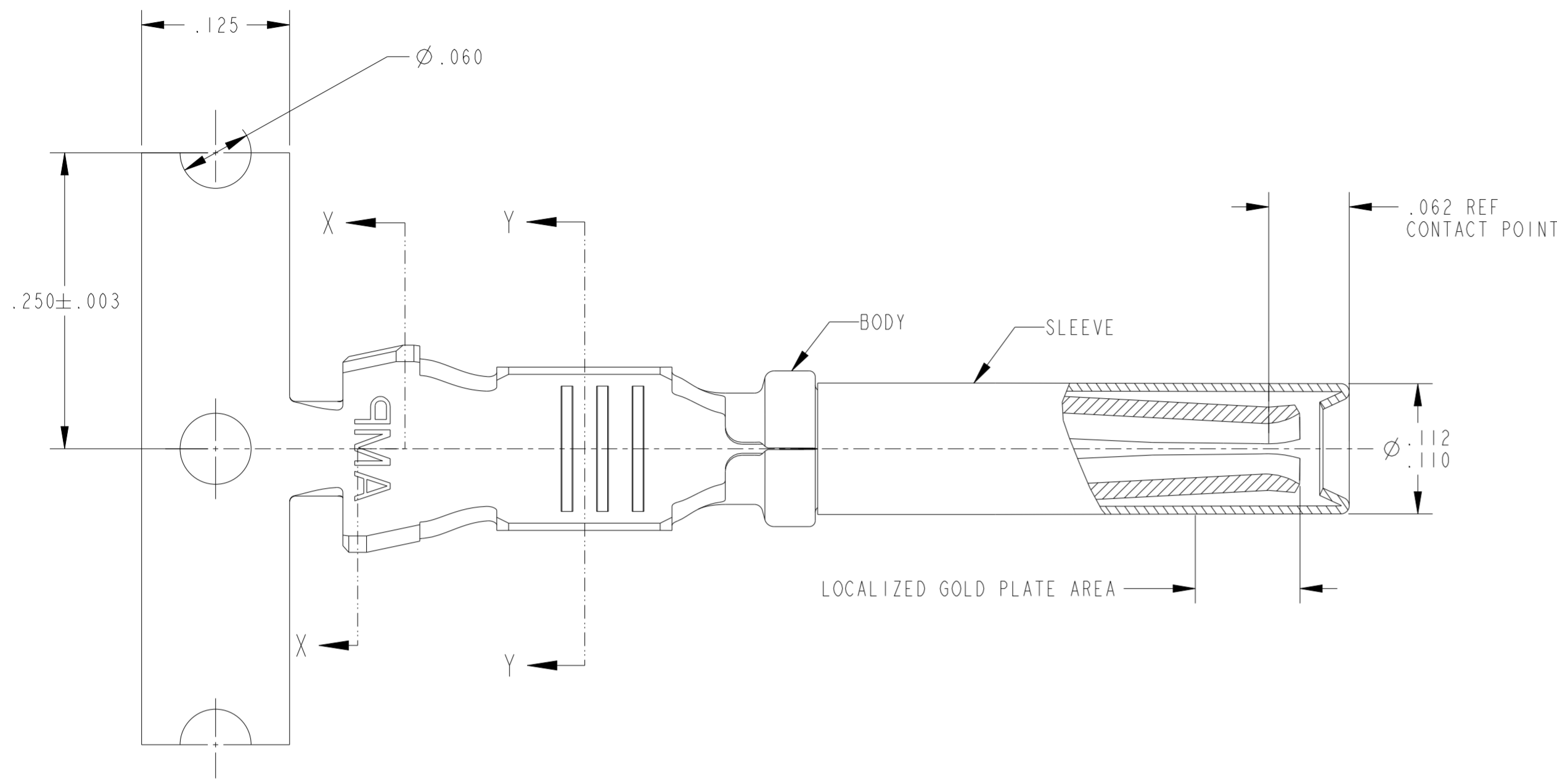
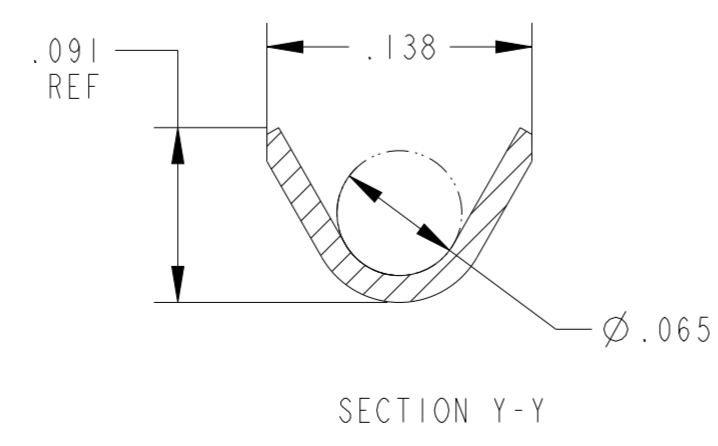
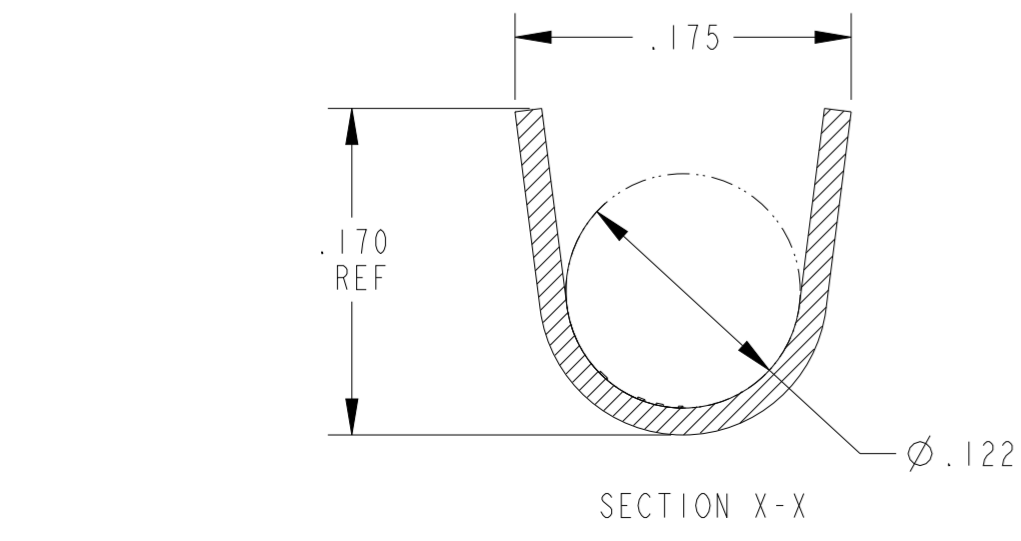

6	776493-2
2	776493-1
FINISH	PART NUMBER

THIS DRAWING IS A CONTROLLED DOCUMENT.		DWN DL DRUMMOND 07MAY2004	STE TE Connectivity	
DIMENSIONS: INCHES		CHK MP TRULL 07MAY2004		
TOLERANCES UNLESS OTHERWISE SPECIFIED:		APVD MP TRULL 07MAY2004	NAME ASSEMBLY SOCKET	
0 PLC ±	1 PLC ±	PRODUCT SPEC 108-2422	-	
2 PLC ±.02	3 PLC ±.005	APPLICATION SPEC 114-13045	SIZE A2	CAGE CODE 00779
4 PLC ±	ANGLES ±	WEIGHT -	DRAWING NO C-776493	RESTRICTED TO -
MATERIAL 1		CUSTOMER DRAWING	SCALE 10:1	SHEET 1 OF 1
SEE TABLE				REV P