

Scope

- The purpose of the document is to specify the functional requirement of a WPC V1.2.0 Qi Wireless Power Supply's TX Module. (WPC V1.2.0 downward compatible WPC V1.1.2)
- The Wireless Power supply's TX Module shall meet the ROHS requirement.

Applications

- Wireless charging pad
- Power bank
- Home appliances, Furniture
- Computer peripheral devices
- Car holder, GPS navigation

Product Characteristic

QPT-0003 is a V1.2.0 Qi-compliant multi-function wireless charging platform: Its transmission efficiency is reached 76.8%. With the Qi certified Low Power receiver the device provides 5W output power. If equipped with Fast Charge labeled Qi receiver device, it can provide up to 10W transmission power, to achieve fast wireless charging.

It adopts intelligent identification system while its transmitter and receiver unit adopts UART (Universal asynchronous receiver/ transmitter) encrypted transmission control signal which is stipulated by WPC V1.2.0 Qi .The console will process the corresponding power adjustment based on the encoding of the receiving unit. This module has fulfilled the WPC V1.2.0 Qi requirement and is certified by Qi.

LED indication light:

- (1) LED is OFF – No power supply
- (2) Green LED is ON continuously – Standby
- (3) Blue LED (D3) is ON continuously – Normal power transmission
- (4) Purple LED (D2 + D3) is ON continuously – Fast charge mode
- (5) Red LED (D2) is ON continuously – Work abnormal
- (6) Work abnormal including:
 - (i) Over Current Protection (OCP): the output current of the receiving end too high.
 - (ii) Over Temperature Protection (OTP): the working temperature of the transmitter too high.
 - (iii) The coil is not aligned: the center of the transmitter and receiver is not aligned.

Input Characteristics

- Input Voltage & Frequency

Item	Minimum	Normal	Maximum
Input Voltage	4.75VDC	5.00VDC	9.50VDC

- Input Current
 - (1) 1.6A Max. @ 9.00VDC Fast Charger
 - (2) 1.6A Max. @ 5.00VDC Qi Charger
- Energy Consumption
At 9.00VDC, average standby power consumption ≤ 0.2W.

Output Characteristics (Rx Module)

- Static Output Characteristics (Vo & R+N)

Output Power	Rated Load		Peak Load	Output Range	R + N
	Min. Load	Max. Load			
10W	0A	1.1A	1.3A	4.75~9.50V	< 450m Vp-p

Note:

Ripple & Noise: Measurement is done by 20MHz bandwidth oscilloscope and the output end paralleled a 0.1uF ceramic capacitor and a 10uF electrolysis capacitor.

- Line & Load Regulation

Output Power	Load Condition		Line Regulation Period	Load Regulation
	Min. Load	Max. Load		
10W	0A	1.1A	< 1S	± 5.0%

Protection Requirement

- Over Temperature Protection (OTP)
When the working temperature of the transmitter too high (>65°C), OTP function self-start, stop output the electromagnetic wave and indicates red LED is on continuously. And when the working temperature is returned to normal, the transmitter returns to normal operation.
- Over Current Protection (OCP)
When the receiving end of the output current exceeds 1.3A(rated capacity: DC9.0V/1A or DC5.0V/1A), the receiving end sends the wrong data in time to the transmitter, the transmitter stops sending the radio electromagnetic wave, and indicates the red LED is on continuously. It will be working normal after restart the transmitter when the fault receiving condition is removed .
- Charge Completion
When received the “charge completed” data packet from the receiver, the transmitter enters a low power state, and the blue LED is on continuously.

Reliability Requirements

- Reliability Test

Test Items	Test Conditions
Storage at high temperature test	+60°C, 16hours
Storage at low temperature test	-20°C, 16hours
Operating at high temperature test	+40°C, 168hours
Operating at low temperature test	-20°C, 48hours
High/Low temperature cycle test	+45°C (2Hrs) → -20°C (2Hrs) → +45°C (2Hrs) → -20°C (2Hrs) continually work 48hours

- Burn-in
2hours at 35°C (±5°C), nominal input voltage, nominal load.
- Carton Dropping Test
(1) Test height : Determined by weight

Equal to or greater than		But less than		Free fall	
lb	Kg	lb	Kg	In	mm
0	0	21	10	30	760
21	10	41	19	24	610
41	19	61	28	18	460
61	28	100	45	12	310
100	45	150	68	8	200

(2) Drop times: 10 times (one triangle, three edge, six surface)

(3) Drop platform: 1~2cm thickness solid wood

- Carton Vibration Test
 - (1) Condition: vibration amplitude 2 mm
 - (2) Frequency: 12.4 Hz
 - (3) Direction: X, Y
 - (4) Time: 30 minutes/pc

Environment Requirement

- Operating Temperature and Relative Humidity
0°C to +40°C, 20%RH to 80%RH @ sea level shall below or no more than 10000 feet.
- Storage Temperature and Relative Humidity
-20°C to +60°C, 10%RH to 90%RH (non-condensing) @ sea level shall below 30000 feet.

Execution Standards (Compatible with these specifications)

- EMC Standards

EN55022	EN55024
---------	---------

- WPC V1.2.0 Qi Standards

Photo of Product

Front Side

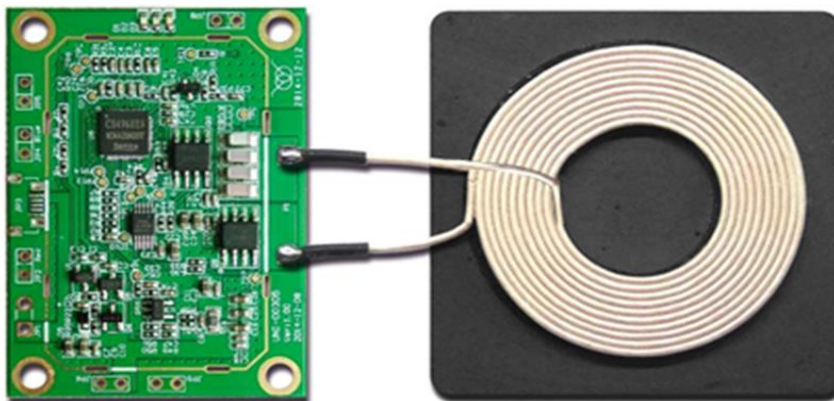

Back Side

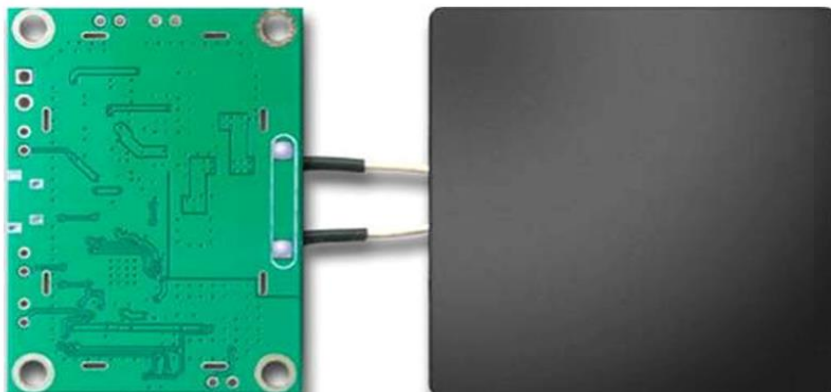

Module

- Product Design Proposal

According to the standardization of Qi, there are three principles need to be careful :

- (1) The distance between Tx Coil with PCB and other metal components is Min: 4.50mm.
- (2) The distance between the surface of Tx Coil and the surface of product (Working Face) is $2.0_{-0.25}^{+0.5}$ mm, which means the thickness of the working face plastic is not more than 2.5mm.
- (3) The surface distance between Tx Coil and Rx Coil is 3.0~4.5mm.

- PCBA Port Functional Illustration

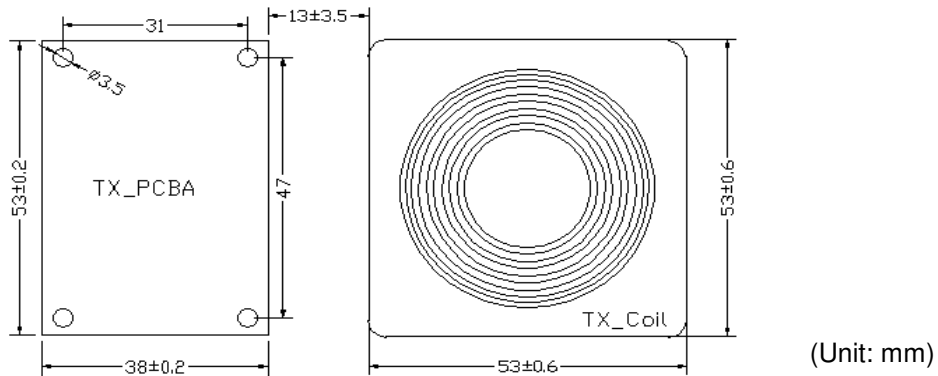

PCBA : 53 * 38 * 2.6±0.2 mm

Coil + Shielding : 53 * 53 * 3.3±0.2 mm

Amount of space between the PCBA to Coil+Shielding as follows: 13±3.5 mm

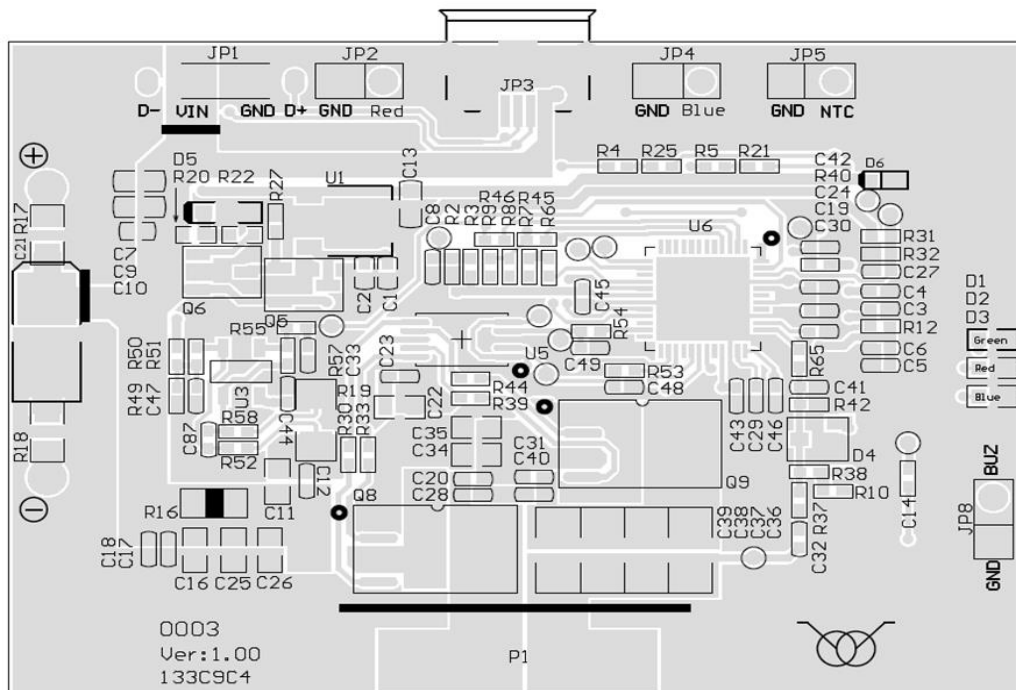

Port	JP1-L	JP1-R	JP2	JP3
Function	5V IN	GND	Red LED	Micro USB
Port	JP4	JP5	JP8	P1
Function	Blue LED	10K NTC	BUZZ	Tx Coil

- Tx Coil Spec

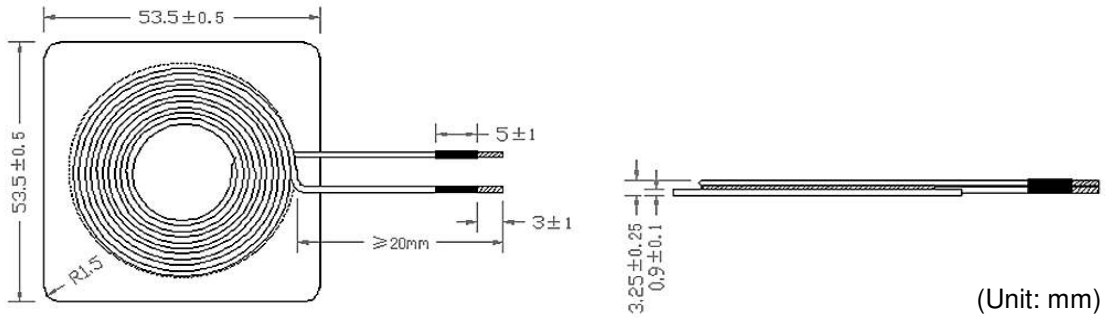

Electrical specification @25°C

Parameters	Unit	Limit
Inductance, LS @100kHz, 1.0V, AGW40# 0.08mm*105 ~10Turns	uH	6.50 ± 10%
Q	---	100 ± 10%
DCR	mΩ	35 ± 10%

Others

- Weight : 25 ± 2 g
- Major Test Equipment
 - DC Supply
 - Rx_Module
 - Electronic Load
 - DPO3014 Digital Phosphor Oscilloscope
 - Logical Analyzer
 - Q110 Qi BST (Base Station Tester)