

Reference	∅ ISO	L (mm)	H1 (mm)	H2 (mm)	Clamping range min/max	Torque (Nm) on the hood	Torque (Nm) on the body	Thread A
UTO10JCS	M16	48.5	14	17	03/06	5	6	9/16-24 UNEF Class 2A
UTO10JCSL	M16	48.5	17	17	05/08	5	6	9/16-24 UNEF Class 2A
UTO12JCS	M20	48.5	20	22	06/10	8	10	11/16-24 UNEF Class 2A
UTO12JCSL	M20	49.5	22	22	08/12	8	10	11/16-24 UNEF Class 2A
UTO14JCS	M20	53.5	20	22	06/10	8	10	13/16-20 UNEF Class 2A
UTO14JCSL	M20	54.5	22	22	08/12	8	10	13/16-20 UNEF Class 2A
UTO16JCS	M25	62.5	24	26	9.5/14	12	14	15/16-20 UNEF Class 2A
UTO16JCSL	M25	68.5	30	30	11.5/18	12	14	15/16-20 UNEF Class 2A
UTO18JCS	M25	65.5	24	26	9.5/14	12	14	1" 1/16-18 UNEF Class 2A
UTO18JCSL	M25	71.5	30	30	11.5/18	12	14	1" 1/16-18 UNEF Class 2A
UTO20JCS	M32	70.5	30	33	11.5/18	20	24	1" 3/16-18 UNEF Class 2A
UTO20JCSL	M32	77.5	40	40	15/24	20	24	1" 3/16-18 UNEF Class 2A
UTO22JCS	M32	76.5	30	33	11.5/18	20	24	1" 5/16-18 UNEF Class 2A
UTO22JCSL	M32	83.5	40	40	15/24	20	24	1" 5/16-18 UNEF Class 2A
UTO24JCS	M32	82.0	30	33	11.5/18	20	24	1" 7/16-18 UNEF Class 2A
UTO24JCSL	M32	89.0	40	40	15/24	20	24	1" 7/16-18 UNEF Class 2A

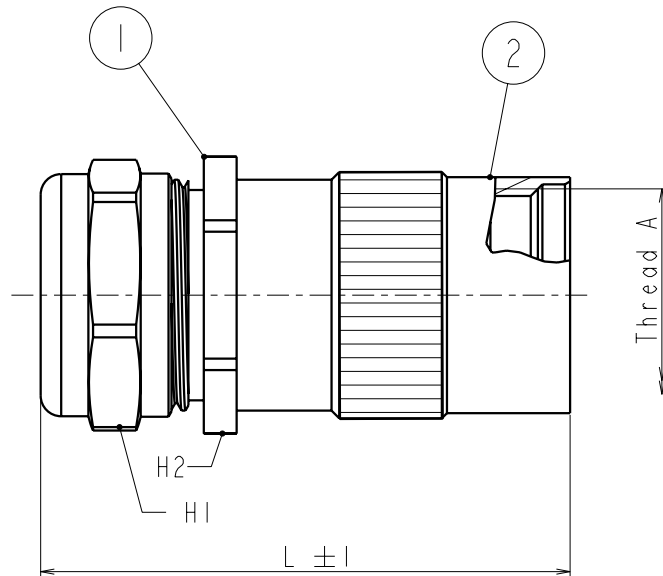

MATERIAL :

Cable clamp: Brass nickel plated
 Tube: Brass nickel plated

PERFORMANCE CHARACTERISTICS :

Operating temperature: -40°C up to 105°C
 Corrosion salt spray: 96 hours

A	07/06/04	--	Creation of the drawing		--
ISS	DATE	Latest modification - by:	--	MOD N°	
Designed by:		C. PROVOST	Date: 07/06/04	Type of drawing:	ASSEMBLAGE
Checked by:		SEE DISTRIBUTION LIST	Date:	SEE DISTRIBUTION LIST	
TITLE		Connector UTO et UTOW Kit cable clamp with tube			
Scale	General angular	MATERIAL : --			
3/1	Tolerances: ± --				
General linear	General machining	Tolerances: ± --		Geometrical Tolerances	PROJECT
	surface texture			See NF E 04-552	MSK1
		SOURIAU Route Nationale 23 72470 CHAMPAGNE Tel. (33)02.43.54.35.00		This document is the property of SOURIAU It must not be reproduced or communicated without permission	
FORMAT	SOURIAU DRG N°			SHEET	
A2	UTOXXJCS-C02			1 / 1	