

Bias Resistor Transistor

PNP Silicon Surface Mount Transistor with Monolithic Bias Resistor Network

This new series of digital transistors is designed to replace a single device and its external resistor bias network. The BRT (Bias Resistor Transistor) contains a single transistor with a monolithic bias network consisting of two resistors; a series base resistor and a base-emitter resistor. The BRT eliminates these individual components by integrating them into a single device. The use of a BRT can reduce both system cost and board space. The device is housed in the SC-59 package which is designed for low power surface mount applications.

- Simplifies Circuit Design
- Reduces Board Space
- Reduces Component Count
- The SC-59 package can be soldered using wave or reflow. The modified gull-winged leads absorb thermal stress during soldering eliminating the possibility of damage to the die.
- Available in 8 mm embossed tape and reel. Use the Device Number to order the 7 inch/3000 unit reel.

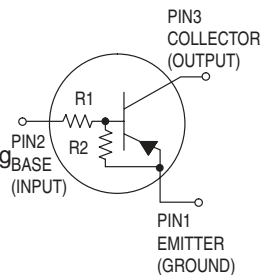

MUN2111T1 SERIES

Motorola Preferred Devices

PNP SILICON BIAS RESISTOR TRANSISTOR



CASE 318D-03, STYLE 1 (SC-59)

MAXIMUM RATINGS (T_A = 25°C unless otherwise noted)

Rating	Symbol	Value	Unit
Collector-Base Voltage	V _{CBO}	50	Vdc
Collector-Emitter Voltage	V _{CEO}	50	Vdc
Collector Current	I _C	100	mAdc
Total Power Dissipation @ T _A = 25°C(1) Derate above 25°C	P _D	200 1.6	mW mW/°C

THERMAL CHARACTERISTICS

Thermal Resistance — Junction-to-Ambient (surface mounted)	R _{θJA}	625	°C/W
Operating and Storage Temperature Range	T _J , T _{stg}	-65 to +150	°C
Maximum Temperature for Soldering Purposes, Time in Solder Bath	T _L	260 10	°C Sec

DEVICE MARKING AND RESISTOR VALUES

Device	Marking	R1 (K)	R2 (K)
MUN2111T1	6A	10	10
MUN2112T1	6B	22	22
MUN2113T1	6C	47	47
MUN2114T1	6D	10	47
MUN2115T1(2)	6E	10	∞
MUN2116T1(2)	6F	4.7	∞
MUN2130T1(2)	6G	1.0	1.0
MUN2131T1(2)	6H	2.2	2.2
MUN2132T1(2)	6J	4.7	4.7
MUN2133T1(2)	6K	4.7	47
MUN2134T1(2)	6L	22	47

1. Device mounted on a FR-4 glass epoxy printed circuit board using the minimum recommended footprint.
2. New devices. Updated curves to follow in subsequent data sheets.

Preferred devices are Motorola recommended choices for future use and best overall value.

MUN211T1 SERIES

ELECTRICAL CHARACTERISTICS ($T_A = 25^\circ\text{C}$ unless otherwise noted)

Characteristic	Symbol	Min	Typ	Max	Unit
OFF CHARACTERISTICS					
Collector–Base Cutoff Current ($V_{CB} = 50\text{ V}$, $I_E = 0$)	I_{CBO}	—	—	100	nAdc
Collector–Emitter Cutoff Current ($V_{CE} = 50\text{ V}$, $I_B = 0$)	I_{CEO}	—	—	500	nAdc
Emitter–Base Cutoff Current ($V_{EB} = 6.0\text{ V}$, $I_C = 0$)	I_{EBO}	—	—	0.5	mAdc
MUN2111T1		—	—	0.2	
MUN2112T1		—	—	0.1	
MUN2113T1		—	—	0.2	
MUN2114T1		—	—	0.9	
MUN2115T1		—	—	1.9	
MUN2116T1		—	—	4.3	
MUN2130T1		—	—	2.3	
MUN2131T1		—	—	1.5	
MUN2132T1		—	—	0.18	
MUN2133T1		—	—	0.13	
MUN2134T1		—	—		
Collector–Base Breakdown Voltage ($I_C = 10\ \mu\text{A}$, $I_E = 0$)	$V_{(BR)CBO}$	50	—	—	Vdc
Collector–Emitter Breakdown Voltage ⁽³⁾ ($I_C = 2.0\text{ mA}$, $I_B = 0$)	$V_{(BR)CEO}$	50	—	—	Vdc
ON CHARACTERISTICS⁽³⁾					
DC Current Gain ($V_{CE} = 10\text{ V}$, $I_C = 5.0\text{ mA}$)	h_{FE}	35	60	—	
MUN2111T1		60	100	—	
MUN2112T1		80	140	—	
MUN2113T1		80	140	—	
MUN2114T1		160	250	—	
MUN2115T1		160	250	—	
MUN2116T1		3.0	5.0	—	
MUN2130T1		8.0	15	—	
MUN2131T1		15	27	—	
MUN2132T1		80	140	—	
MUN2133T1		80	130	—	
MUN2134T1					
Collector–Emitter Saturation Voltage ($I_C = 10\text{ mA}$, $I_B = 0.3\text{ mA}$)	$V_{CE(sat)}$	—	—	0.25	Vdc
MUN2111T1		—	—	0.25	
MUN2112T1		—	—	0.25	
MUN2113T1		—	—	0.25	
MUN2114T1		—	—	0.25	
MUN2115T1		—	—	0.25	
MUN2130T1		—	—	0.25	
($I_C = 10\text{ mA}$, $I_B = 5.0\text{ mA}$)		—	—	0.25	
MUN2131T1		—	—	0.25	
($I_C = 10\text{ mA}$, $I_B = 1.0\text{ mA}$)		—	—	0.25	
MUN2116T1		—	—	0.25	
MUN2132T1		—	—	0.25	
MUN2134T1		—	—	0.25	
Output Voltage (on) ($V_{CC} = 5.0\text{ V}$, $V_B = 2.5\text{ V}$, $R_L = 1.0\text{ k}\Omega$)	V_{OL}	—	—	0.2	Vdc
MUN2111T1		—	—	0.2	
MUN2112T1		—	—	0.2	
MUN2114T1		—	—	0.2	
MUN2115T1		—	—	0.2	
MUN2116T1		—	—	0.2	
MUN2130T1		—	—	0.2	
MUN2131T1		—	—	0.2	
MUN2132T1		—	—	0.2	
MUN2133T1		—	—	0.2	
MUN2134T1		—	—	0.2	
($V_{CC} = 5.0\text{ V}$, $V_B = 3.5\text{ V}$, $R_L = 1.0\text{ k}\Omega$)		—	—	0.2	
MUN2113T1		—	—	0.2	

3. Pulse Test: Pulse Width < 300 μs , Duty Cycle < 2.0%

ELECTRICAL CHARACTERISTICS (Continued) ($T_A = 25^\circ\text{C}$ unless otherwise noted)

Characteristic	Symbol	Min	Typ	Max	Unit
Output Voltage (off) ($V_{CC} = 5.0\text{ V}$, $V_B = 0.5\text{ V}$, $R_L = 1.0\text{ k}\Omega$) ($V_{CC} = 5.0\text{ V}$, $V_B = 0.050\text{ V}$, $R_L = 1.0\text{ k}\Omega$) MUN2130T1 ($V_{CC} = 5.0\text{ V}$, $V_B = 0.25\text{ V}$, $R_L = 1.0\text{ k}\Omega$) MUN2115T1 MUN2116T1 MUN2131T1 MUN2132T1	V_{OH}	4.9	—	—	Vdc
Input Resistor MUN2111T1 MUN2112T1 MUN2113T1 MUN2114T1 MUN2115T1 MUN2116T1 MUN2130T1 MUN2131T1 MUN2132T1 MUN2133T1 MUN2134T1	R1	7.0 15.4 32.9 7.0 7.0 3.3 0.7 1.5 3.3 3.3 15.4	10 22 47 10 10 4.7 1.0 2.2 4.7 4.7 22	13 28.6 61.1 13 13 6.1 1.3 2.9 6.1 6.1 28.6	k Ω
Resistor Ratio MUN2111T1/MUN2112T1/MUN2113T1 MUN2114T1 MUN2115T1/MUN2116T1 MUN2130T1/MUN2131T1/MUN2132T1 MUN2133T1 MUN2134T1	R_1/R_2	0.8 0.17 — 0.8 0.055 0.38	1.0 0.21 — 1.0 0.1 0.47	1.2 0.25 — 1.2 0.185 0.56	

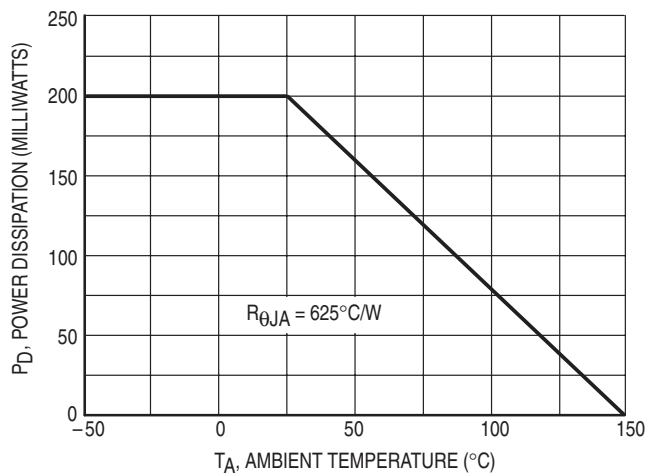

Figure 1. Derating Curve

TYPICAL ELECTRICAL CHARACTERISTICS — MUN2111T1

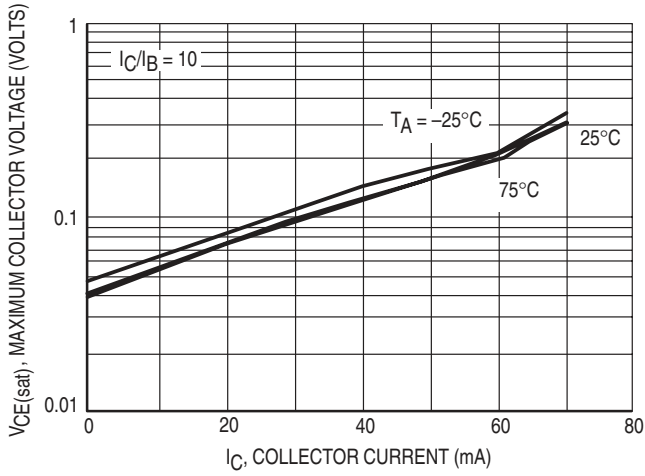

Figure 2. $V_{CE(sat)}$ versus I_C

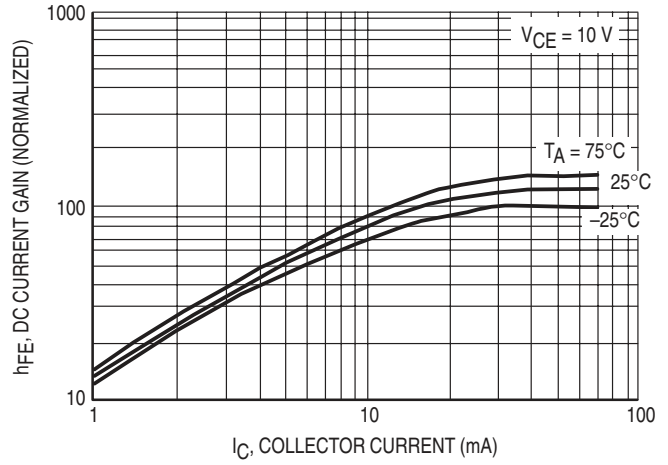

Figure 3. DC Current Gain

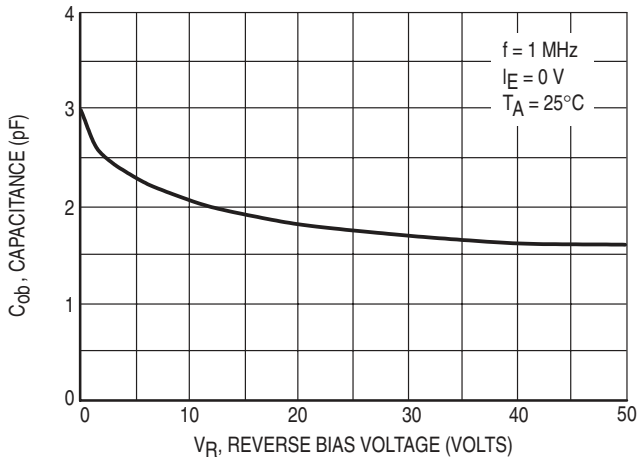

Figure 4. Output Capacitance

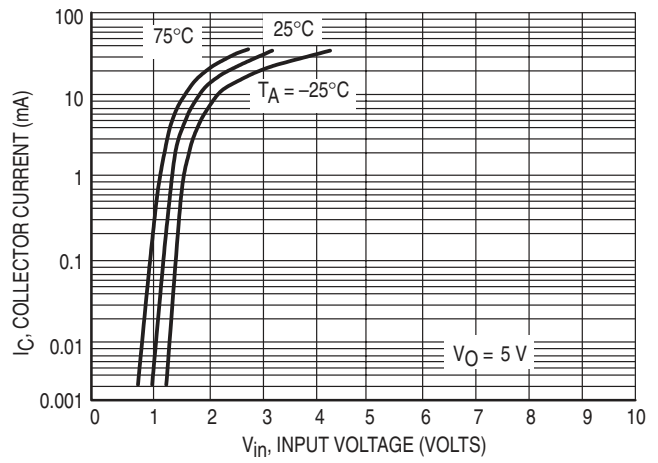

Figure 5. Output Current versus Input Voltage

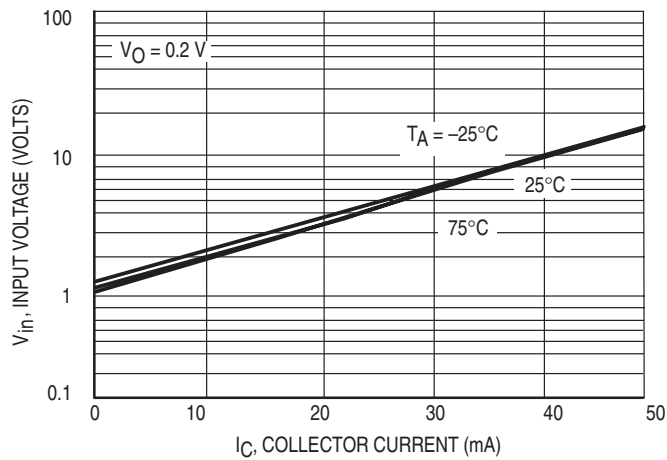

Figure 6. Input Voltage versus Output Current

TYPICAL ELECTRICAL CHARACTERISTICS — MUN2112T1

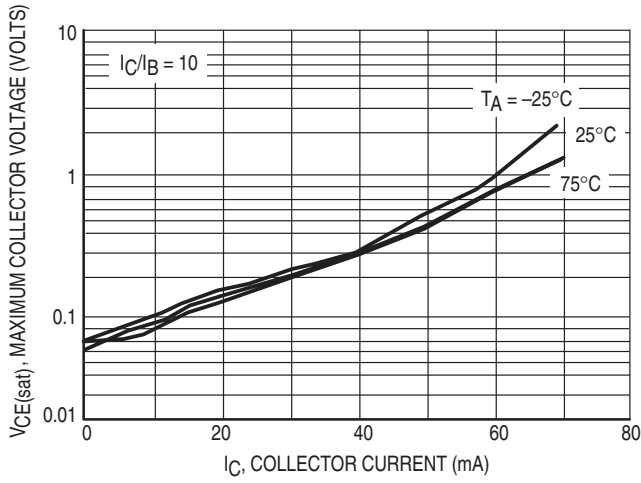

Figure 7. $V_{CE(sat)}$ versus I_C

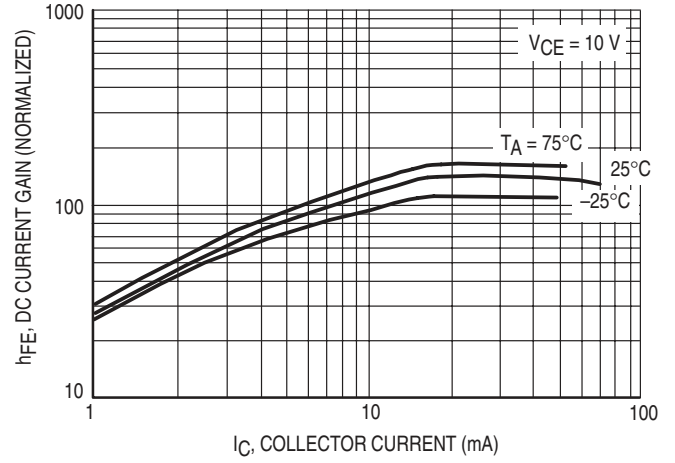

Figure 8. DC Current Gain

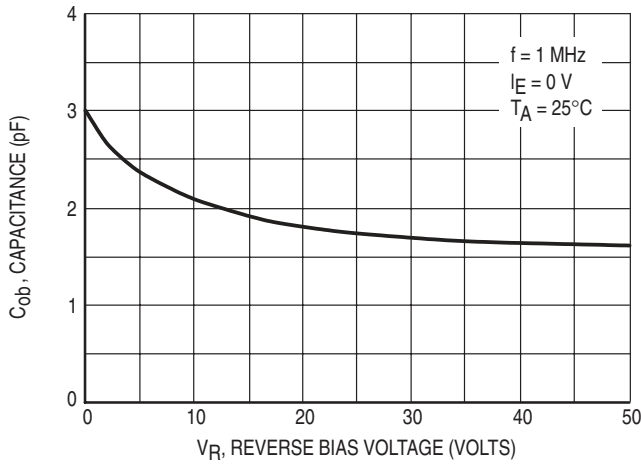

Figure 9. Output Capacitance

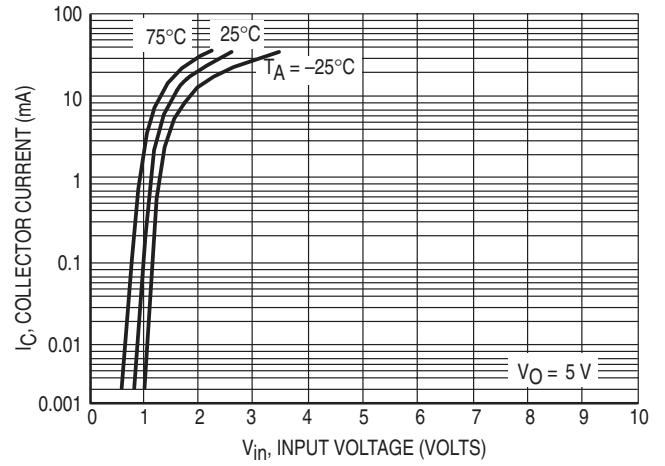

Figure 10. Output Current versus Input Voltage

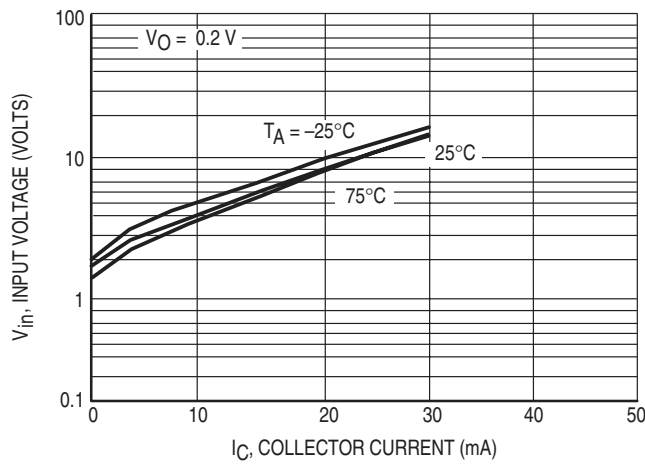

Figure 11. Input Voltage versus Output Current

TYPICAL ELECTRICAL CHARACTERISTICS — MUN2113T1

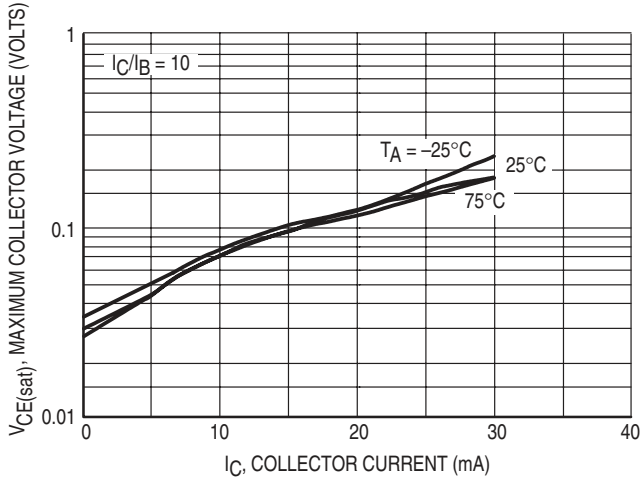

Figure 12. $V_{CE(sat)}$ versus I_C

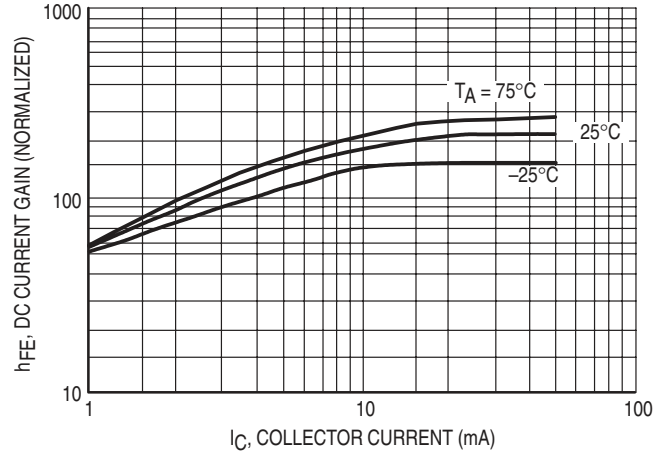

Figure 13. DC Current Gain

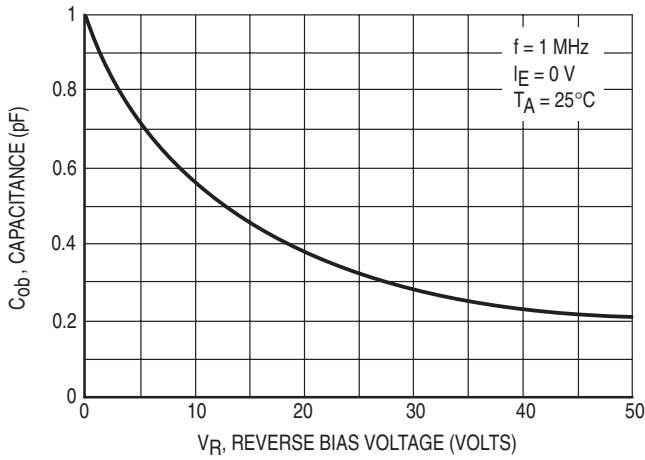

Figure 14. Output Capacitance

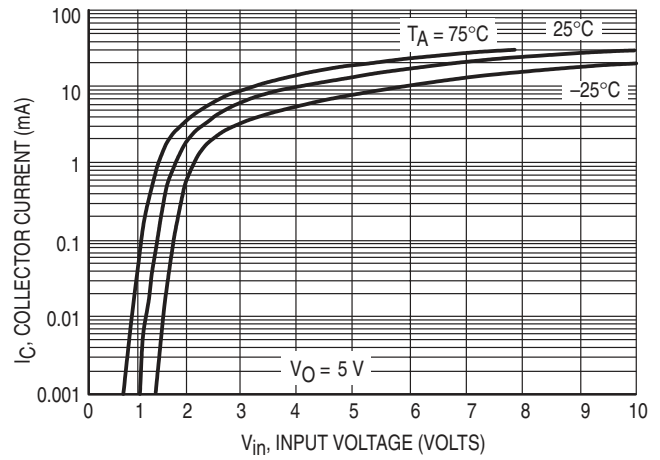

Figure 15. Output Current versus Input Voltage

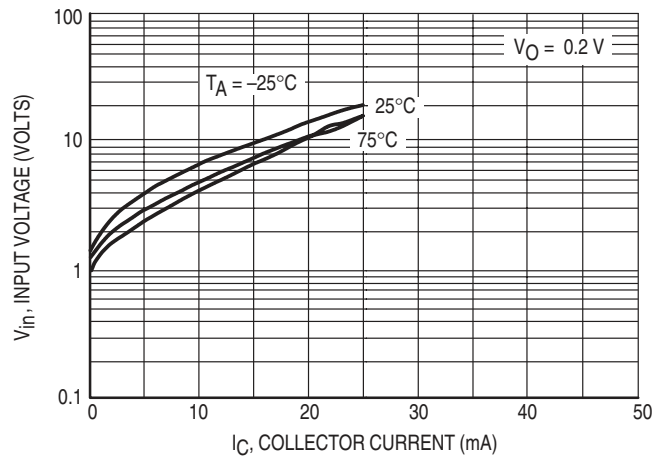

Figure 16. Input Voltage versus Output Current

TYPICAL ELECTRICAL CHARACTERISTICS — MUN2114T1

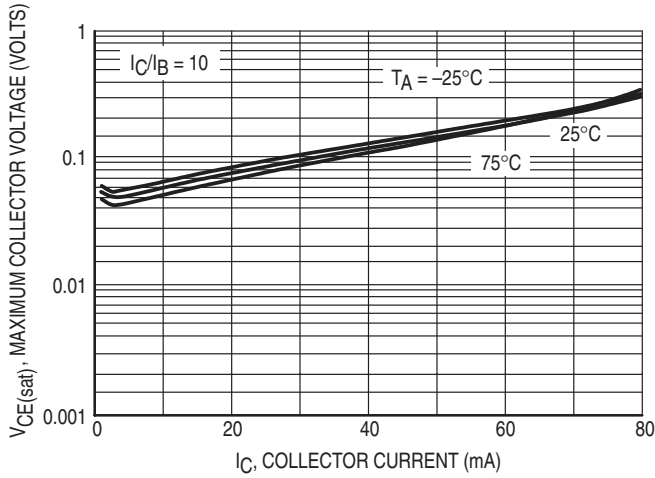

Figure 17. $V_{CE(sat)}$ versus I_C

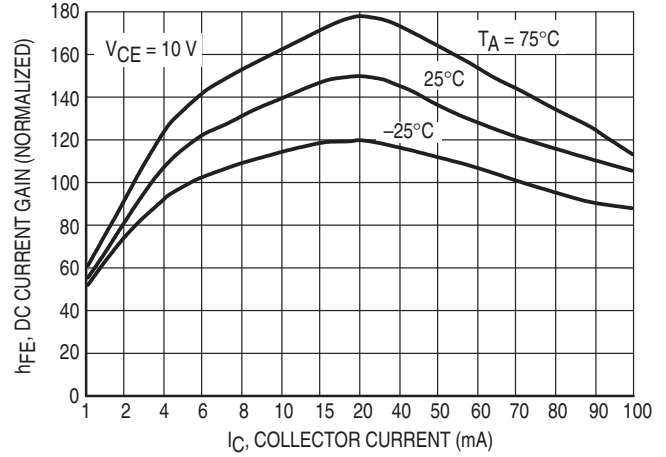

Figure 18. DC Current Gain

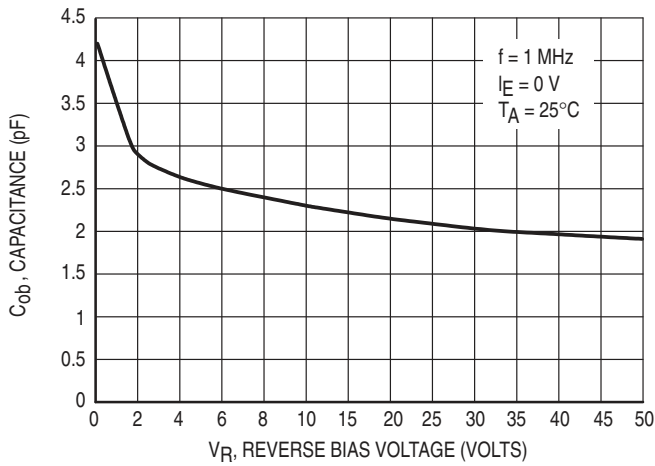

Figure 19. Output Capacitance

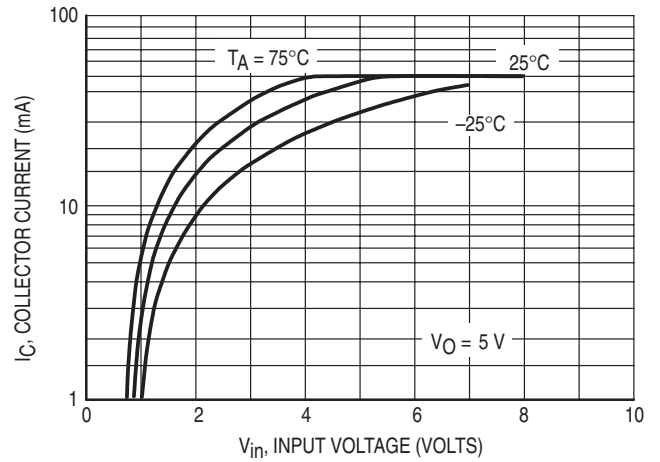

Figure 20. Output Current versus Input Voltage

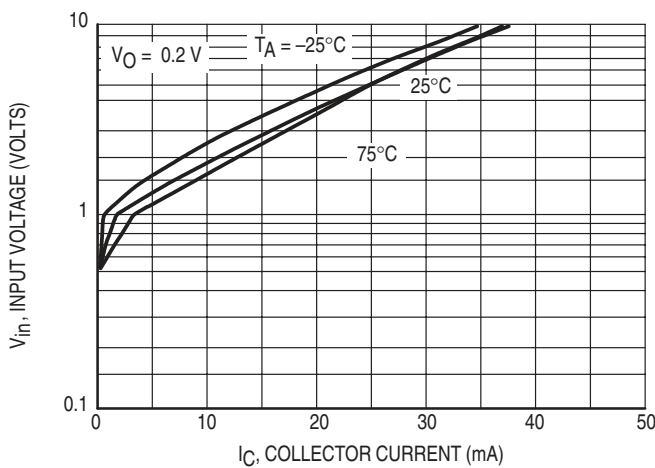

Figure 21. Input Voltage versus Output Current

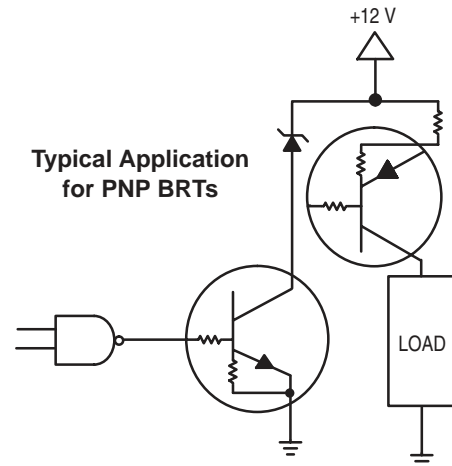

Figure 22. Inexpensive, Unregulated Current Source

EMBOSSSED TAPE AND REEL

SOT-23, SC-59, SC-70/SOT-323, SC-90/SOT-416, SOT-223 and SO-16 packages are available only in Tape and Reel. Use the appropriate suffix indicated below to order any of the SOT-23, SC-59, SC-70/SOT-323, SOT-223 and SO-16 packages. (See Section 6 on Packaging for additional information).

- SOT-23: available in 8 mm Tape and Reel
Use the device title (which already includes the "T1" suffix) to order the 7 inch/3000 unit reel.
Replace the "T1" suffix in the device title with a "T3" suffix to order the 13 inch/10,000 unit reel.
- SC-59: available in 8 mm Tape and Reel
Use the device title (which already includes the "T1" suffix) to order the 7 inch/3000 unit reel.
Replace the "T1" suffix in the device title with a "T3" suffix to order the 13 inch/10,000 unit reel.
- SC-70/
SOT-323: available in 8 mm Tape and Reel
Use the device title (which already includes the "T1" suffix) to order the 7 inch/3000 unit reel.
Replace the "T1" suffix in the device title with a "T3" suffix to order the 13 inch/10,000 unit reel.
- SOT-223: available in 12 mm Tape and Reel
Use the device title (which already includes the "T1" suffix) to order the 7 inch/1000 unit reel.
Replace the "T1" suffix in the device title with a "T3" suffix to order the 13 inch/4000 unit reel.
- SO-16: available in 16 mm Tape and Reel
Add an "R1" suffix to the device title to order the 7 inch/500 unit reel.
Add an "R2" suffix to the device title to order the 13 inch/2500 unit reel.

RADIAL TAPE IN FAN FOLD BOX OR REEL

TO-92 packages are available in both bulk shipments and in Radial Tape in Fan Fold Boxes or Reels. Fan Fold Boxes and Radial Tape Reel are the best methods for capturing devices for automatic insertion in printed circuit boards.

- TO-92: available in Fan Fold Box
Add an "RLR" suffix and the appropriate Style code* to the device title to order the Fan Fold box.
- available in 365 mm Radial Tape Reel
Add an "RLR" suffix and the appropriate Style code* to the device title to order the Radial Tape Reel.

*Refer to Section 6 on Packaging for Style code characters and additional information on ordering requirements.

DEVICE MARKINGS/DATE CODE CHARACTERS

SOT-23, SC-59, SC-70/SOT-323, and the SC-90/SOT-416 packages have a device marking and a date code etched on the device. The generic example below depicts both the device marking and a representation of the date code that appears on the SC-70/SOT-323, SC-59 and SOT-23 packages.



The "D" represents a smaller alpha digit Date Code. The Date Code indicates the actual month in which the part was manufactured.

Tape and Reel Specifications and Packaging Specifications

Embossed Tape and Reel is used to facilitate automatic pick and place equipment feed requirements. The tape is used as the shipping container for various products and requires a minimum of handling. The antistatic/conductive tape provides a secure cavity for the product when sealed with the "peel-back" cover tape.

- Two Reel Sizes Available (7" and 13")
- Used for Automatic Pick and Place Feed Systems
- Minimizes Product Handling
- EIA 481, -1, -2
- SOD-123, SC-59, SC-70/SOT-323, SC-70ML/SOT-363, SOT-23, TSOP-6, in 8 mm Tape
- SOT-223 in 12 mm Tape
- SO-14, SO-16 in 16 mm Tape

Use the standard device title and add the required suffix as listed in the option table on the following page. Note that the individual reels have a finite number of devices depending on the type of product contained in the tape. Also note the minimum lot size is one full reel for each line item, and orders are required to be in increments of the single reel quantity.

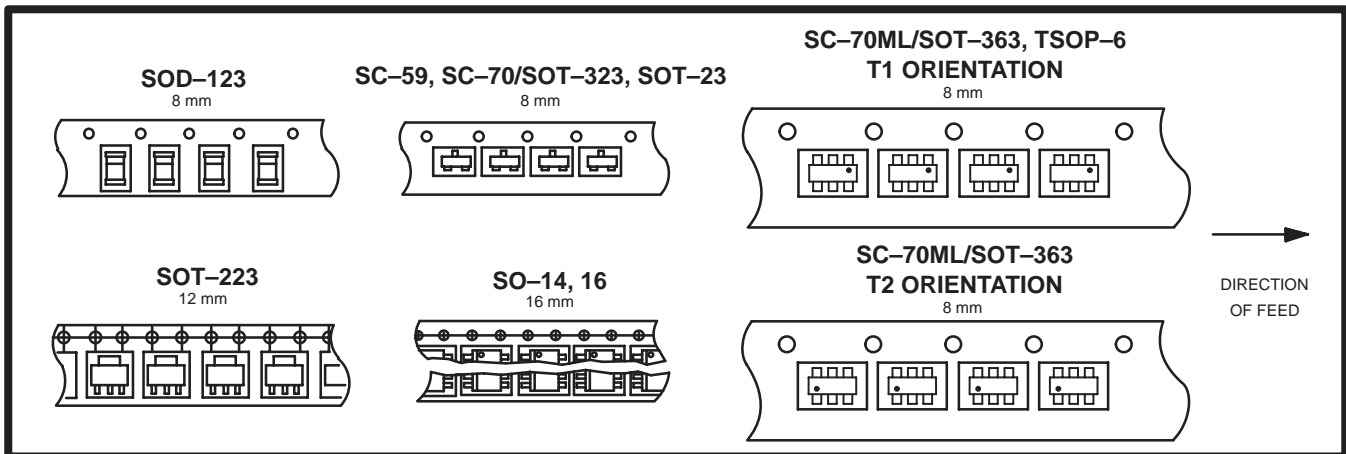

EMBOSSED TAPE AND REEL ORDERING INFORMATION

Package	Tape Width (mm)	Pitch (mm (inch))	Reel Size (mm (inch))	Devices Per Reel and Minimum Order Quantity	Device Suffix
SC-59	8	4.0 ± 0.1 (.157 ± .004)	178 (7)	3,000	T1
SC-70/SOT-323	8	4.0 ± 0.1 (.157 ± .004)	178 (7)	3,000	T1
	8		330 (13)	10,000	T3
SO-14	16	8.0 ± 0.1 (.315 ± .004)	178 (7)	500	R1
	16		330 (13)	2,500	R2
SO-16	16	8.0 ± 0.1 (.315 ± .004)	178 (7)	500	R1
	16		330 (13)	2,500	R2
SOD-123	8	4.0 ± 0.1 (.157 ± .004)	178 (7)	3,000	T1
	8		330 (13)	10,000	T3
SOT-23	8	4.0 ± 0.1 (.157 ± .004)	178 (7)	3,000	T1
	8		330 (13)	10,000	T3
SOT-223	12	8.0 ± 0.1 (.315 ± .004)	178 (7)	1,000	T1
	12		330 (13)	4,000	T3
SC-70ML/SOT-363	8	4.0 ± 0.1 (.157 ± .004)	178 (7)	3,000	T1
	8		178 (7)	3,000	T2
TSOP-6	8	4.0 ± 0.1 (.157 ± .004)	178 (7)	3,000	T1

EMBOSSED TAPE AND REEL DATA FOR DISCRETES

CARRIER TAPE SPECIFICATIONS

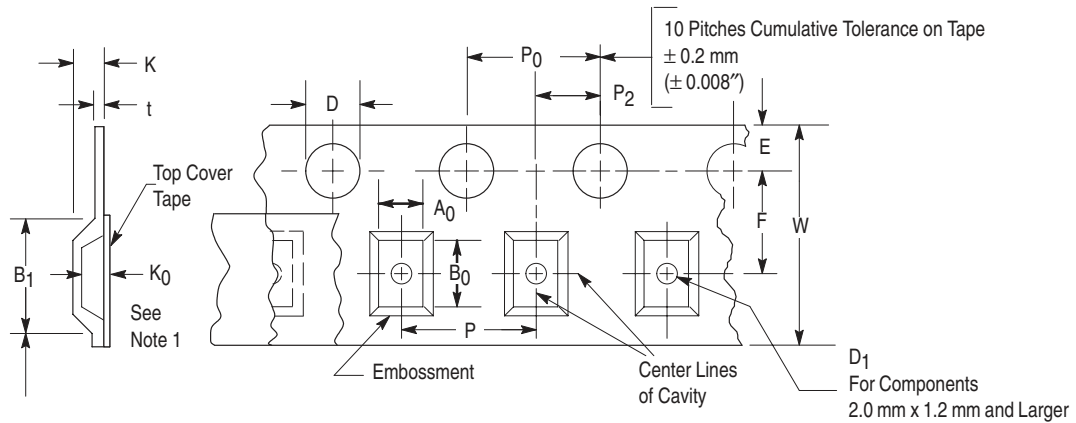

For Machine Reference Only
 Including Draft and RADII
 Concentric Around B_0

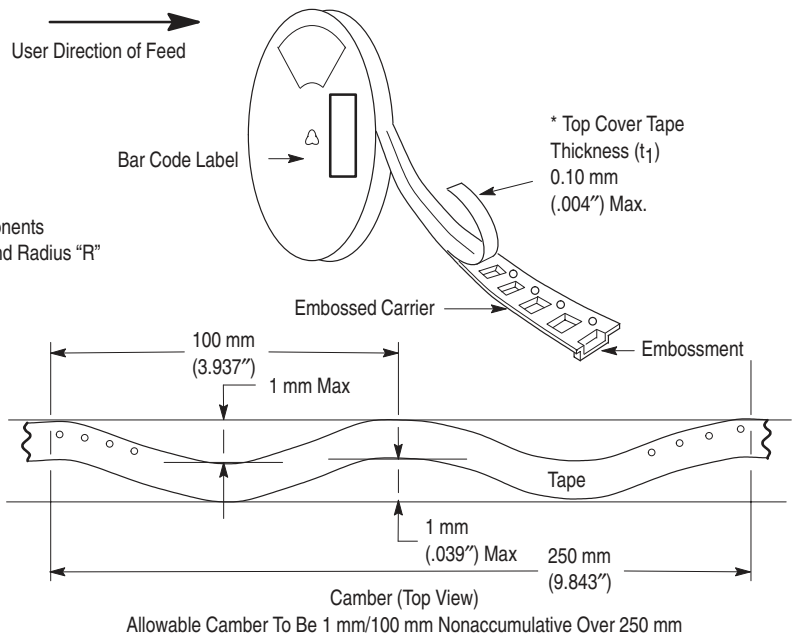
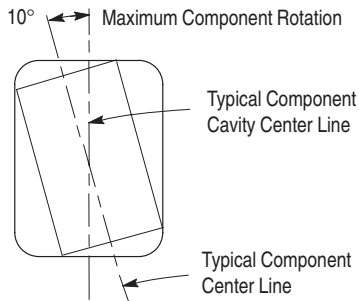
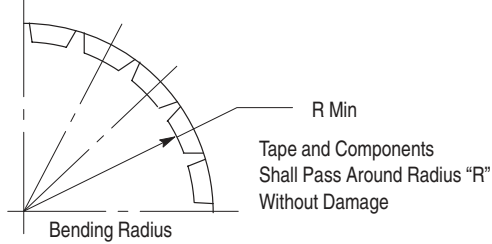

DIMENSIONS

Tape Size	B_1 Max	D	D_1	E	F	K	P_0	P_2	R Min	T Max	W Max
8 mm	4.55 mm (.179")	1.5 ± 0.1 mm -0.0 (.059 ± .004" -0.0)	1.0 Min (.039")	1.75 ± 0.1 mm (.069 ± .004")	3.5 ± 0.05 mm (.138 ± .002")	2.4 mm Max (.094")	4.0 ± 0.1 mm (.157 ± .004")	2.0 ± 0.1 mm (.079 ± .002")	25 mm (.98")	0.6 mm (.024")	8.3 mm (.327")
12 mm	8.2 mm (.323")		1.5 mm Min (.060")		5.5 ± 0.05 mm (.217 ± .002")	6.4 mm Max (.252")			30 mm (1.18")		12 ± .30 mm (.470 ± .012")
16 mm	12.1 mm (.476")				7.5 ± 0.10 mm (.295 ± .004")	7.9 mm Max (.311")					16.3 mm (.642")
24 mm	20.1 mm (.791")				11.5 ± 0.1 mm (.453 ± .004")	11.9 mm Max (.468")					24.3 mm (.957")

Metric dimensions govern — English are in parentheses for reference only.

NOTE 1: A_0 , B_0 , and K_0 are determined by component size. The clearance between the components and the cavity must be within .05 mm min. to .50 mm max., the component cannot rotate more than 10° within the determined cavity.

NOTE 2: If B_1 exceeds 4.2 mm (.165) for 8 mm embossed tape, the tape may not feed through all tape feeders.

NOTE 3: Pitch information is contained in the Embossed Tape and Reel Ordering Information on pg. 5.12-3.

EMBOSSED TAPE AND REEL DATA FOR DISCRETES

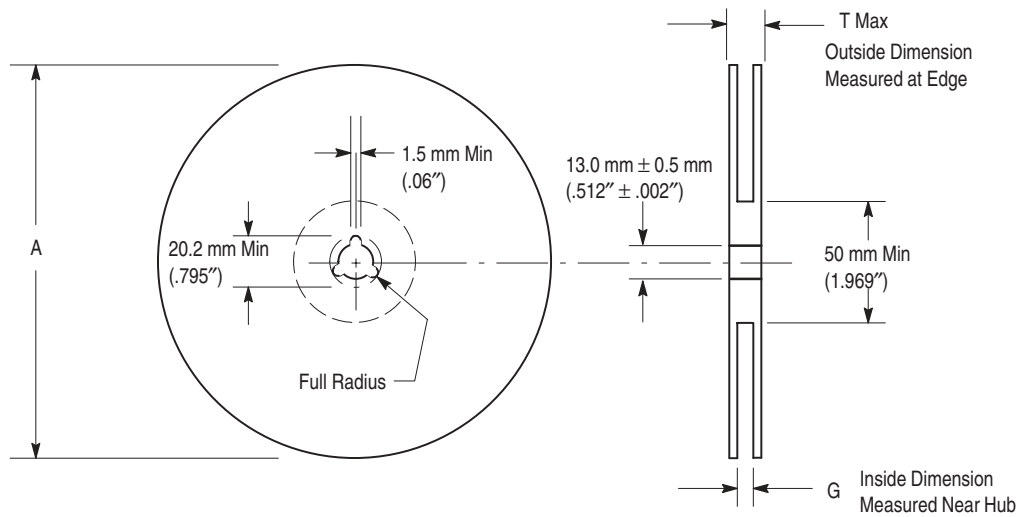

Size	A Max	G	T Max
8 mm	330 mm (12.992")	8.4 mm + 1.5 mm, -0.0 (.33" + .059", -0.00)	14.4 mm (.56")
12 mm	330 mm (12.992")	12.4 mm + 2.0 mm, -0.0 (.49" + .079", -0.00)	18.4 mm (.72")
16 mm	360 mm (14.173")	16.4 mm + 2.0 mm, -0.0 (.646" + .078", -0.00)	22.4 mm (.882")
24 mm	360 mm (14.173")	24.4 mm + 2.0 mm, -0.0 (.961" + .070", -0.00)	30.4 mm (1.197")

Reel Dimensions

Metric Dimensions Govern — English are in parentheses for reference only

TO-92 EIA, IEC, EIAJ

Radial Tape in Fan Fold Box or On Reel

Radial tape in fan fold box or on reel of the reliable TO-92 package are the best methods of capturing devices for automatic insertion in printed circuit boards. These methods of taping are compatible with various equipment for active and passive component insertion.

- Available in Fan Fold Box
- Available on 365 mm Reels
- Accommodates All Standard Inserters
- Allows Flexible Circuit Board Layout
- 2.5 mm Pin Spacing for Soldering
- EIA-468, IEC 286-2, EIAJ RC1008B

Ordering Notes:

When ordering radial tape in fan fold box or on reel, specify the style per Figures 3 through 8. Add the suffix "RLR" and "Style" to the device title, i.e. MPS3904RLRA. This will be a standard MPS3904 radial taped and supplied on a reel per Figure 9.

Fan Fold Box Information — Order in increments of 2000.

Reel Information — Order in increments of 2000.

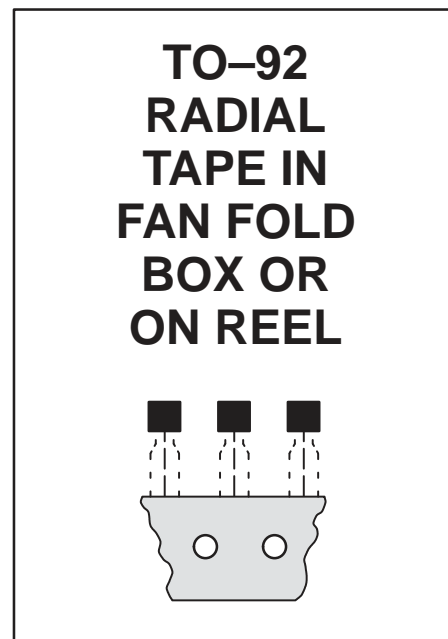

US/European Suffix Conversions

US	EUROPE
RLRA	RL
RLRE	RL1
RLRM	ZL1

TO-92 EIA RADIAL TAPE IN FAN FOLD BOX OR ON REEL

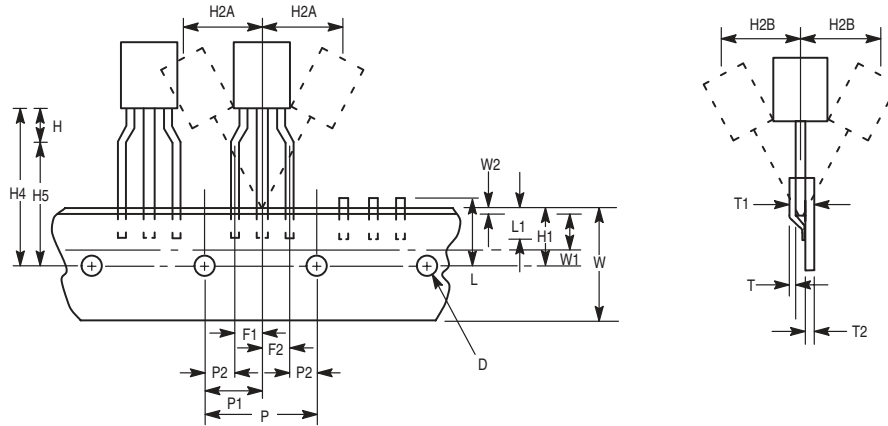

Figure 1. Device Positioning on Tape

Symbol	Item	Specification			
		Inches		Millimeter	
		Min	Max	Min	Max
D	Tape Feedhole Diameter	0.1496	0.1653	3.8	4.2
D2	Component Lead Thickness Dimension	0.015	0.020	0.38	0.51
F1, F2	Component Lead Pitch	0.0945	0.110	2.4	2.8
H	Bottom of Component to Seating Plane	.059	.156	1.5	4.0
H1	Feedhole Location	0.3346	0.3741	8.5	9.5
H2A	Deflection Left or Right	0	0.039	0	1.0
H2B	Deflection Front or Rear	0	0.051	0	1.0
H4	Feedhole to Bottom of Component	0.7086	0.768	18	19.5
H5	Feedhole to Seating Plane	0.610	0.649	15.5	16.5
L	Defective Unit Clipped Dimension	0.3346	0.433	8.5	11
L1	Lead Wire Enclosure	0.09842	—	2.5	—
P	Feedhole Pitch	0.4921	0.5079	12.5	12.9
P1	Feedhole Center to Center Lead	0.2342	0.2658	5.95	6.75
P2	First Lead Spacing Dimension	0.1397	0.1556	3.55	3.95
T	Adhesive Tape Thickness	0.06	0.08	0.15	0.20
T1	Overall Taped Package Thickness	—	0.0567	—	1.44
T2	Carrier Strip Thickness	0.014	0.027	0.35	0.65
W	Carrier Strip Width	0.6889	0.7481	17.5	19
W1	Adhesive Tape Width	0.2165	0.2841	5.5	6.3
W2	Adhesive Tape Position	.0059	0.01968	.15	0.5

NOTES:

1. Maximum alignment deviation between leads not to be greater than 0.2 mm.
2. Defective components shall be clipped from the carrier tape such that the remaining protrusion (L) does not exceed a maximum of 11 mm.
3. Component lead to tape adhesion must meet the pull test requirements established in Figures 5, 6 and 7.
4. Maximum non-cumulative variation between tape feed holes shall not exceed 1 mm in 20 pitches.
5. Holddown tape not to extend beyond the edge(s) of carrier tape and there shall be no exposure of adhesive.
6. No more than 1 consecutive missing component is permitted.
7. A tape trailer and leader, having at least three feed holes is required before the first and after the last component.
8. Splices will not interfere with the sprocket feed holes.

TO-92 EIA RADIAL TAPE IN FAN FOLD BOX OR ON REEL

FAN FOLD BOX STYLES

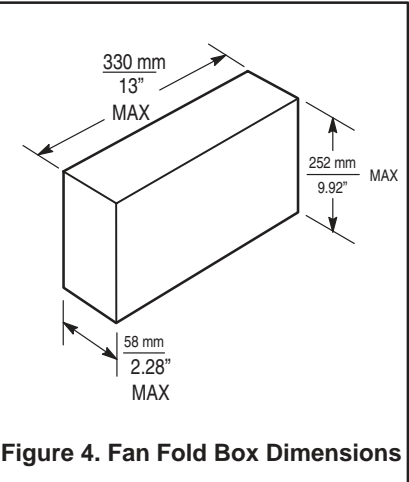
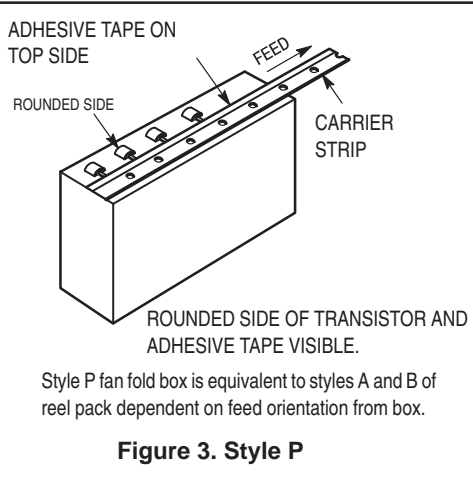
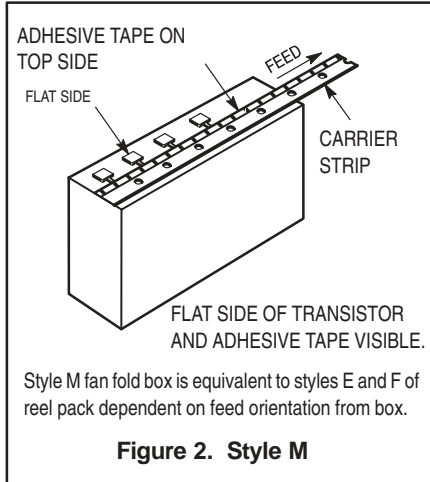

ADHESION PULL TESTS

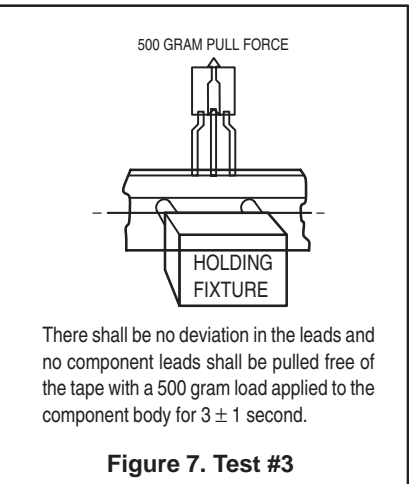
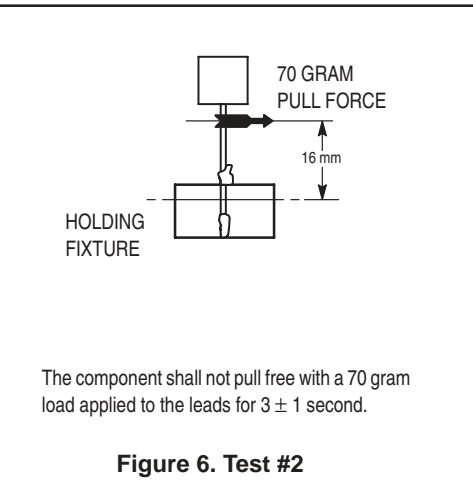
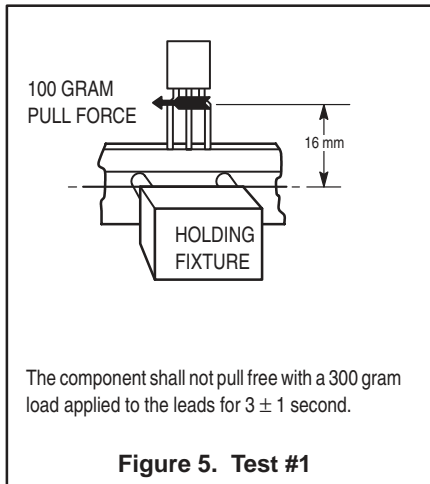

TO-92 EIA RADIAL TAPE IN FAN FOLD BOX OR ON REEL

REEL STYLES

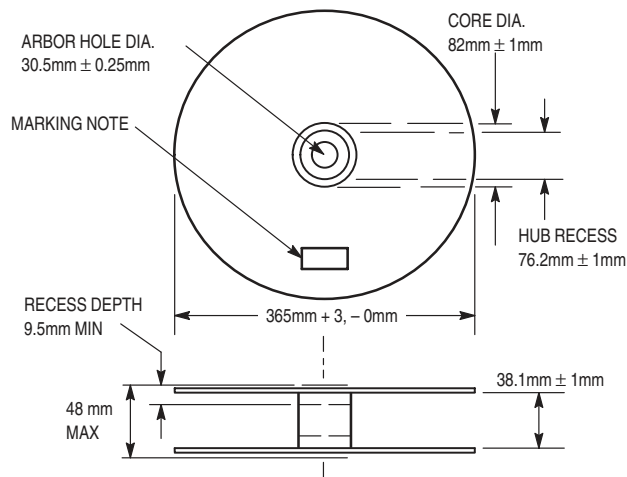

Material used must not cause deterioration of components or degrade lead solderability

Figure 8. Reel Specifications

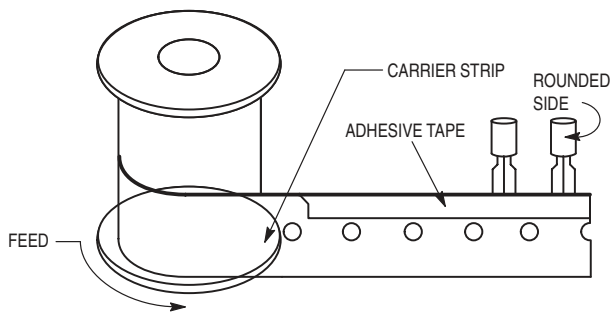

Rounded side of transistor and adhesive tape visible.

Figure 9. Style A

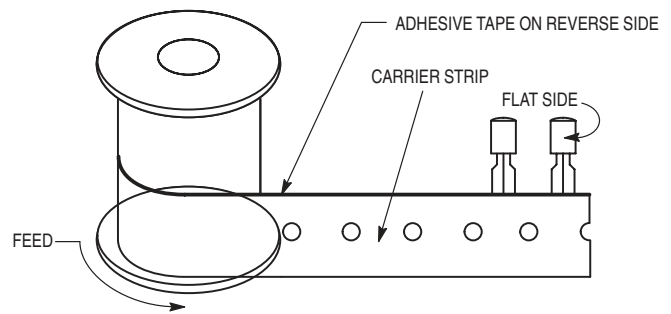

Flat side of transistor and carrier strip visible (adhesive tape on reverse side).

Figure 10. Style B

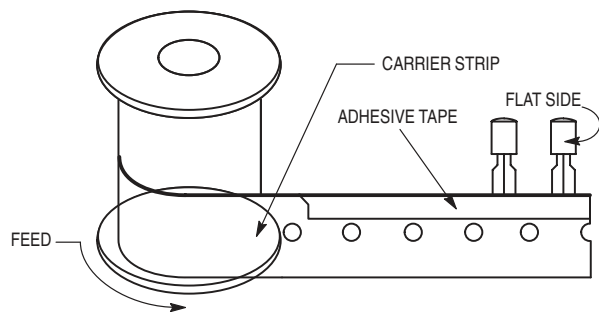

Flat side of transistor and adhesive tape visible.

Figure 11. Style E

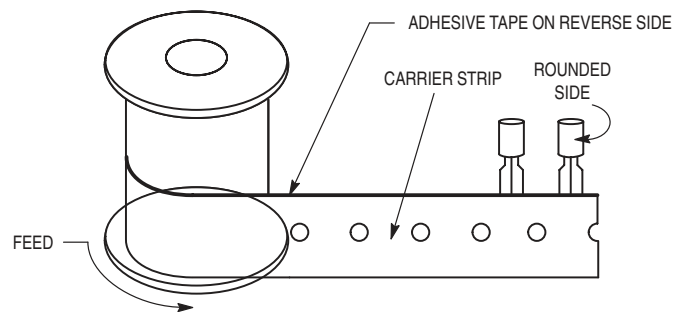

Rounded side of transistor and carrier strip visible (adhesive tape on reverse side).

Figure 12. Style F

INFORMATION FOR USING SURFACE MOUNT PACKAGES

RECOMMENDED FOOTPRINTS FOR SURFACE MOUNTED APPLICATIONS

Surface mount board layout is a critical portion of the total design. The footprint for the semiconductor packages must be the correct size to ensure proper solder connection inter-

face between the board and the package. With the correct pad geometry, the packages will self align when subjected to a solder reflow process.

POWER DISSIPATION FOR A SURFACE MOUNT DEVICE

The power dissipation for a surface mount device is a function of the drain/collector pad size. These can vary from the minimum pad size for soldering to a pad size given for maximum power dissipation. Power dissipation for a surface mount device is determined by $T_{J(max)}$, the maximum rated junction temperature of the die, $R_{\theta JA}$, the thermal resistance from the device junction to ambient, and the operating temperature, T_A . Using the values provided on the data sheet, P_D can be calculated as follows:

$$P_D = \frac{T_{J(max)} - T_A}{R_{\theta JA}}$$

The values for the equation are found in the maximum ratings table on the data sheet. Substituting these values into the equation for an ambient temperature T_A of 25°C, one can calculate the power dissipation of the device. For example, for a SOT-223 device, P_D is calculated as follows.

$$P_D = \frac{150^\circ\text{C} - 25^\circ\text{C}}{156^\circ\text{C/W}} = 800 \text{ milliwatts}$$

The 156°C/W for the SOT-223 package assumes the use of the recommended footprint on a glass epoxy printed circuit board to achieve a power dissipation of 800 milliwatts. There are other alternatives to achieving higher power dissipation from the surface mount packages. One is to increase the area of the drain/collector pad. By increasing the area of the drain/collector pad, the power dissipation can be increased.

SOLDER STENCIL GUIDELINES

Prior to placing surface mount components onto a printed circuit board, solder paste must be applied to the pads. Solder stencils are used to screen the optimum amount. These stencils are typically 0.008 inches thick and may be made of brass or stainless steel. For packages such as the

Although the power dissipation can almost be doubled with this method, area is taken up on the printed circuit board which can defeat the purpose of using surface mount technology. For example, a graph of $R_{\theta JA}$ versus drain pad area is shown in Figure 1.

Another alternative would be to use a ceramic substrate or an aluminum core board such as Thermal Clad™. Using a board material such as Thermal Clad, an aluminum core board, the power dissipation can be doubled using the same footprint.

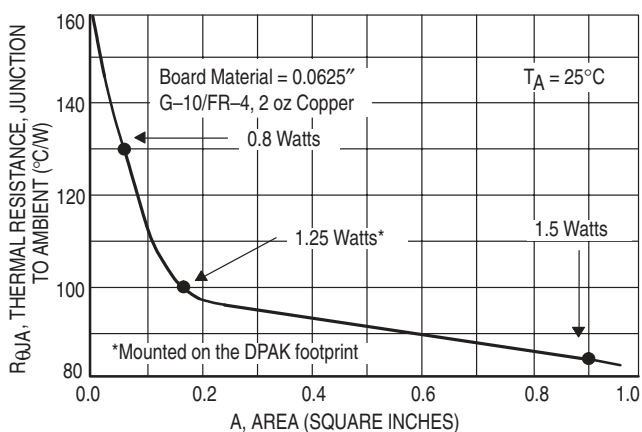

Figure 1. Thermal Resistance versus Drain Pad Area for the SOT-223 Package (Typical)

SOT-23, SC-59, SC-70/SOT-323, SC-90/SOT-416, SOD-123, SOT-223, SOT-363, SO-14, SO-16, and TSOP-6 packages, the stencil opening should be the same as the pad size or a 1:1 registration.

SOLDERING PRECAUTIONS

The melting temperature of solder is higher than the rated temperature of the device. When the entire device is heated to a high temperature, failure to complete soldering within a short time could result in device failure. Therefore, the following items should always be observed in order to minimize the thermal stress to which the devices are subjected.

- Always preheat the device.
- The delta temperature between the preheat and soldering should be 100°C or less.*
- When preheating and soldering, the temperature of the leads and the case must not exceed the maximum temperature ratings as shown on the data sheet. When using infrared heating with the reflow soldering method, the difference should be a maximum of 10°C.

- The soldering temperature and time should not exceed 260°C for more than 10 seconds.
- When shifting from preheating to soldering, the maximum temperature gradient shall be 5°C or less.
- After soldering has been completed, the device should be allowed to cool naturally for at least three minutes. Gradual cooling should be used since the use of forced cooling will increase the temperature gradient and will result in latent failure due to mechanical stress.
- Mechanical stress or shock should not be applied during cooling.

* Soldering a device without preheating can cause excessive thermal shock and stress which can result in damage to the device.

TYPICAL SOLDER HEATING PROFILE

For any given circuit board, there will be a group of control settings that will give the desired heat pattern. The operator must set temperatures for several heating zones and a figure for belt speed. Taken together, these control settings make up a heating "profile" for that particular circuit board. On machines controlled by a computer, the computer remembers these profiles from one operating session to the next. Figure 2 shows a typical heating profile for use when soldering a surface mount device to a printed circuit board. This profile will vary among soldering systems, but it is a good starting point. Factors that can affect the profile include the type of soldering system in use, density and types of components on the board, type of solder used, and the type of board or substrate material being used. This profile shows temperature versus time. The line on the graph shows the

actual temperature that might be experienced on the surface of a test board at or near a central solder joint. The two profiles are based on a high density and a low density board. The Vitronics SMD310 convection/infrared reflow soldering system was used to generate this profile. The type of solder used was 62/36/2 Tin Lead Silver with a melting point between 177–189°C. When this type of furnace is used for solder reflow work, the circuit boards and solder joints tend to heat first. The components on the board are then heated by conduction. The circuit board, because it has a large surface area, absorbs the thermal energy more efficiently, then distributes this energy to the components. Because of this effect, the main body of a component may be up to 30 degrees cooler than the adjacent solder joints.

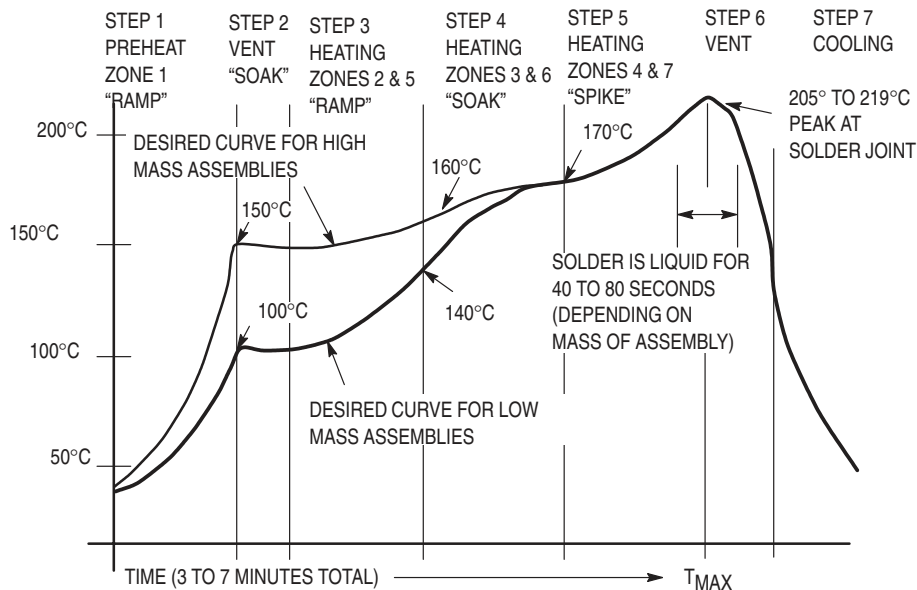
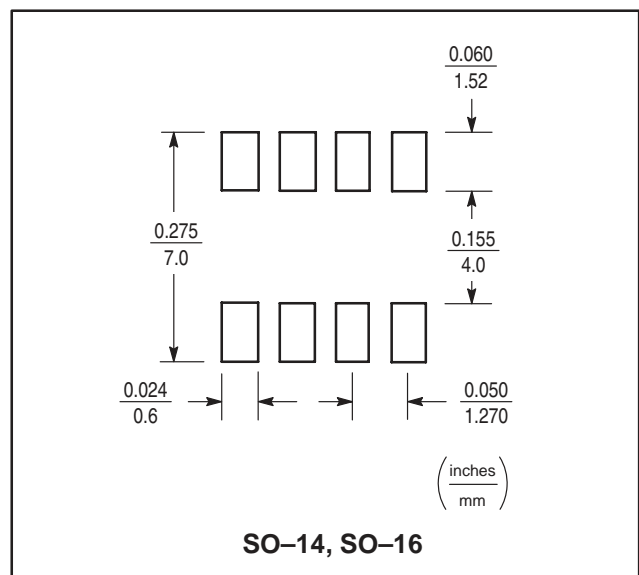
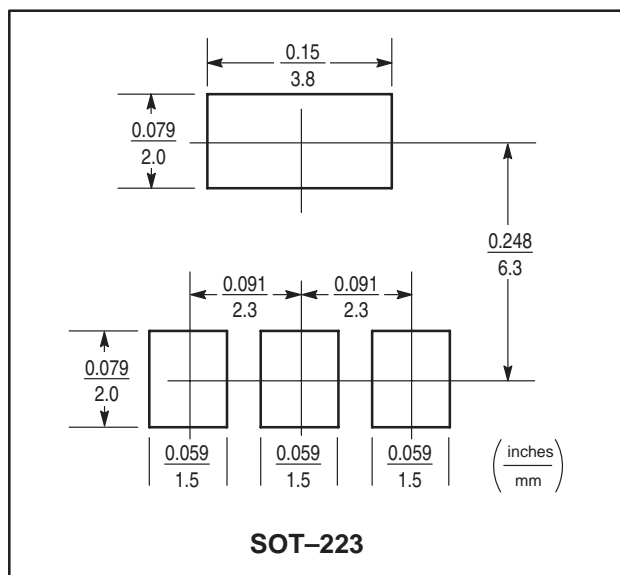
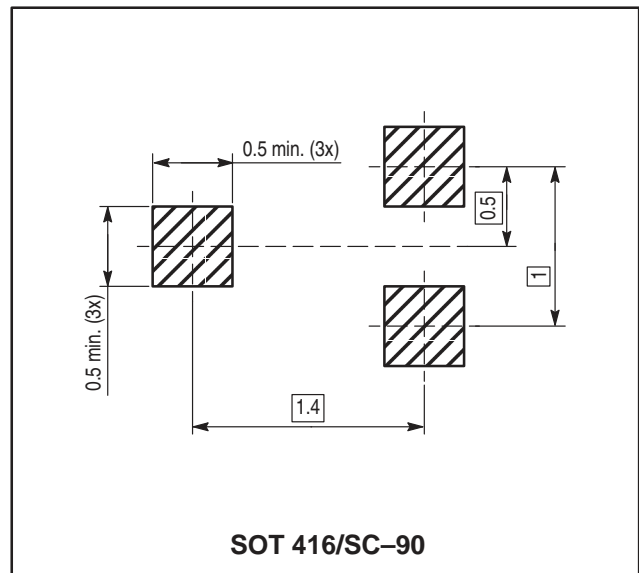
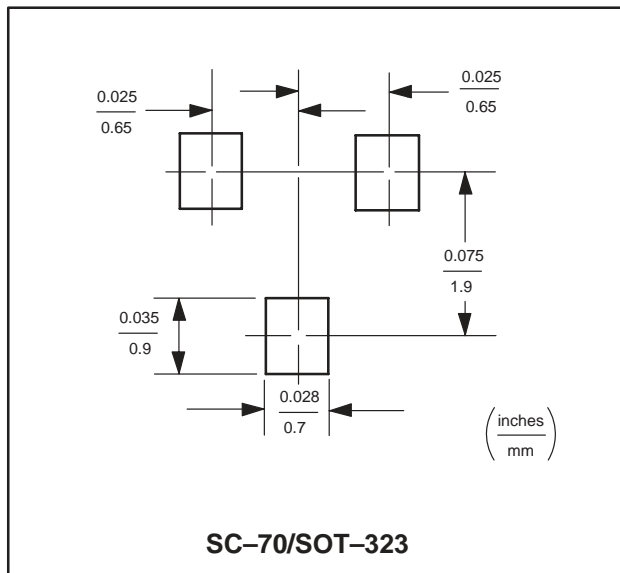
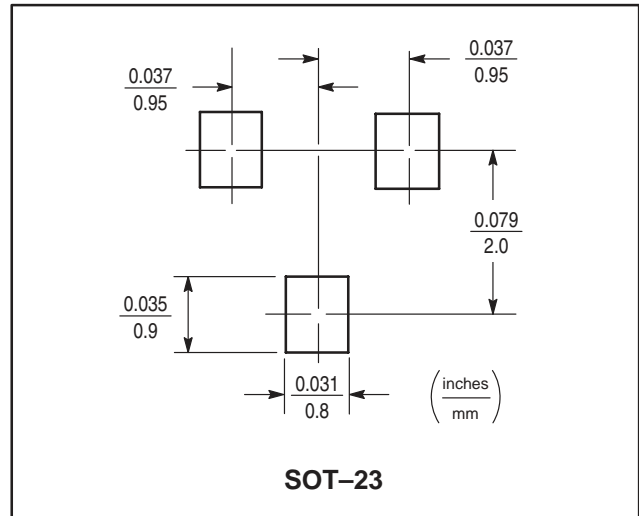
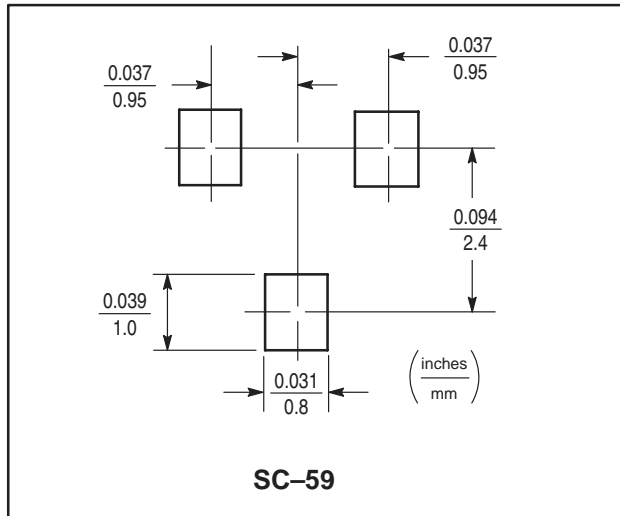
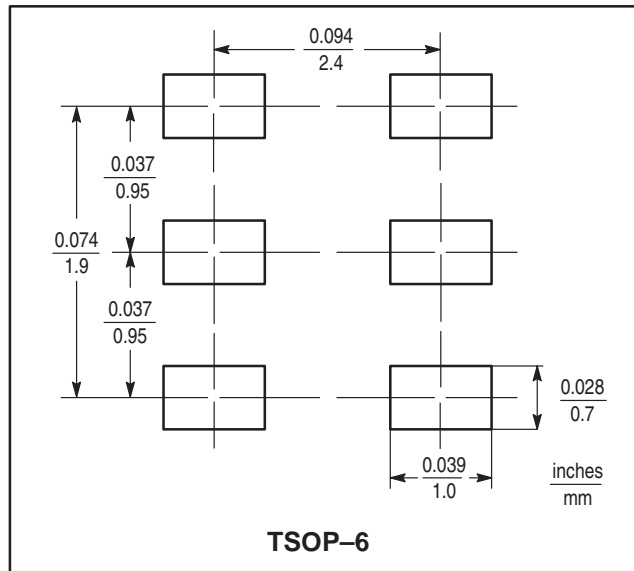
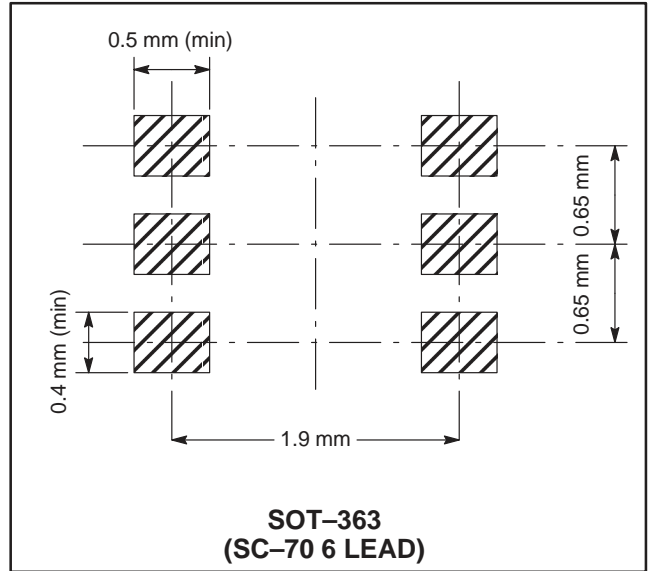
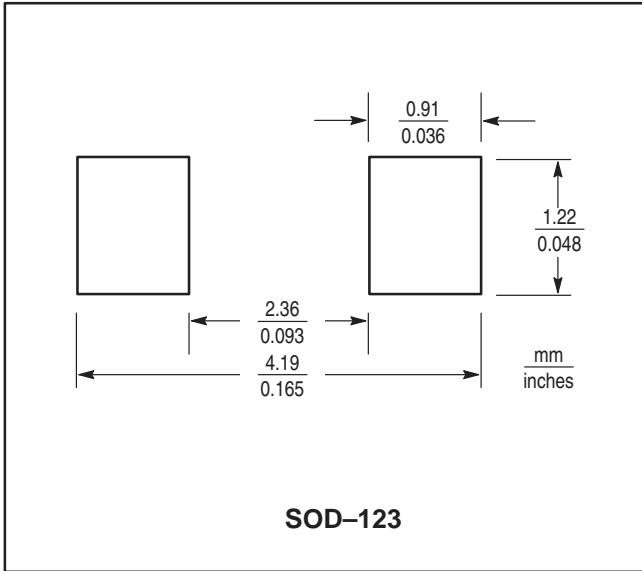

Figure 2. Typical Solder Heating Profile

Footprints for Soldering





Package Outline Dimensions

Dimensions are in inches unless otherwise noted.

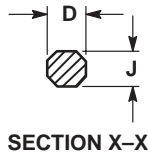
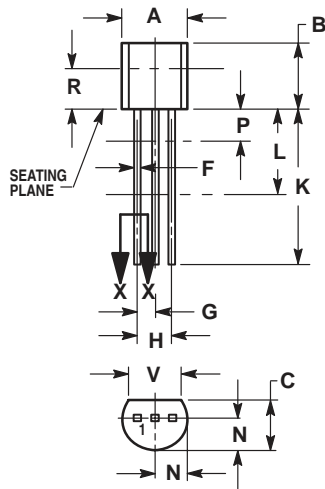

- NOTES:
1. DIMENSIONING AND TOLERANCING PER ANSI Y14.5M, 1982.
 2. CONTROLLING DIMENSION: INCH.
 3. CONTOUR OF PACKAGE BEYOND DIMENSION R IS UNCONTROLLED.
 4. DIMENSION F APPLIES BETWEEN P AND L. DIMENSION D AND J APPLY BETWEEN L AND K. MINIMUM LEAD DIMENSION IS UNCONTROLLED IN P AND BEYOND DIMENSION K MINIMUM.

DIM	INCHES		MILLIMETERS	
	MIN	MAX	MIN	MAX
A	0.175	0.205	4.45	5.20
B	0.170	0.210	4.32	5.33
C	0.125	0.165	3.18	4.19
D	0.016	0.022	0.41	0.55
F	0.016	0.019	0.41	0.48
G	0.045	0.055	1.15	1.39
H	0.095	0.105	2.42	2.66
J	0.015	0.020	0.39	0.50
K	0.500	—	12.70	—
L	0.250	—	6.35	—
N	0.080	0.105	2.04	2.66
P	—	0.100	—	2.54
R	0.115	—	2.93	—
V	0.135	—	3.43	—

- | | | | | | |
|--|---|--|--|---|---|
| <p>STYLE 1:
PIN 1. EMITTER
2. BASE
3. COLLECTOR</p> | <p>STYLE 2:
PIN 1. BASE
2. EMITTER
3. COLLECTOR</p> | <p>STYLE 3:
PIN 1. ANODE
2. ANODE
3. CATHODE</p> | <p>STYLE 4:
PIN 1. CATHODE
2. CATHODE
3. ANODE</p> | <p>STYLE 5:
PIN 1. DRAIN
2. SOURCE
3. GATE</p> | <p>STYLE 7:
PIN 1. SOURCE
2. DRAIN
3. GATE</p> |
| <p>STYLE 14:
PIN 1. EMITTER
2. COLLECTOR
3. BASE</p> | <p>STYLE 15:
PIN 1. ANODE 1
2. CATHODE
3. ANODE 2</p> | <p>STYLE 17:
PIN 1. COLLECTOR
2. BASE
3. EMITTER</p> | <p>STYLE 21:
PIN 1. COLLECTOR
2. EMITTER
3. BASE</p> | <p>STYLE 22:
PIN 1. SOURCE
2. GATE
3. DRAIN</p> | <p>STYLE 30:
PIN 1. DRAIN
2. GATE
3. SOURCE</p> |

CASE 029-04 (TO-226AA) TO-92 PLASTIC

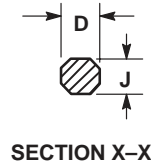
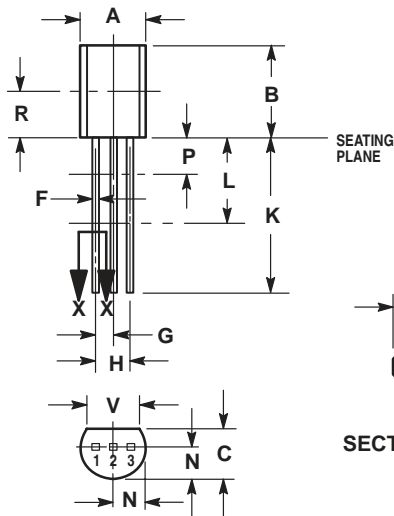

- NOTES:
1. DIMENSIONING AND TOLERANCING PER ANSI Y14.5M, 1982.
 2. CONTROLLING DIMENSION: INCH.
 3. CONTOUR OF PACKAGE BEYOND DIMENSION R IS UNCONTROLLED.
 4. DIMENSION F APPLIES BETWEEN P AND L. DIMENSIONS D AND J APPLY BETWEEN L AND K. MINIMUM LEAD DIMENSION IS UNCONTROLLED IN P AND BEYOND DIMENSION K MINIMUM.

DIM	INCHES		MILLIMETERS	
	MIN	MAX	MIN	MAX
A	0.175	0.205	4.44	5.21
B	0.290	0.310	7.37	7.87
C	0.125	0.165	3.18	4.19
D	0.018	0.022	0.46	0.56
F	0.016	0.019	0.41	0.48
G	0.045	0.055	1.15	1.39
H	0.095	0.105	2.42	2.66
J	0.018	0.024	0.46	0.61
K	0.500	—	12.70	—
L	0.250	—	6.35	—
N	0.080	0.105	2.04	2.66
P	—	0.100	—	2.54
R	0.135	—	3.43	—
V	0.135	—	3.43	—

- | | | |
|---|--|---|
| <p>STYLE 1:
PIN 1. EMITTER
2. BASE
3. COLLECTOR</p> | <p>STYLE 14:
PIN 1. EMITTER
2. COLLECTOR
3. BASE</p> | <p>STYLE 22:
PIN 1. SOURCE
2. GATE
3. DRAIN</p> |
|---|--|---|

CASE 029-05 (TO-226AE) TO-92 1-WATT PLASTIC

PACKAGE OUTLINE DIMENSIONS (continued)

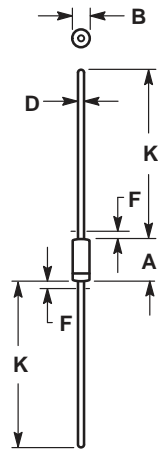

NOTES:

1. PACKAGE CONTOUR OPTIONAL WITHIN DIA B AND LENGTH A. HEAT SLUGS, IF ANY, SHALL BE INCLUDED WITHIN THIS CYLINDER, BUT SHALL NOT BE SUBJECT TO THE MIN LIMIT OF DIA B.
2. LEAD DIA NOT CONTROLLED IN ZONES F, TO ALLOW FOR FLASH, LEAD FINISH BUILDUP, AND MINOR IRREGULARITIES OTHER THAN HEAT SLUGS.

DIM	MILLIMETERS		INCHES	
	MIN	MAX	MIN	MAX
A	5.84	7.62	0.230	0.300
B	2.16	2.72	0.085	0.107
D	0.46	0.56	0.018	0.022
F	—	1.27	—	0.050
K	25.40	38.10	1.000	1.500

All JEDEC dimensions and notes apply.

CASE 51-02
(DO-204AA)
DO-7

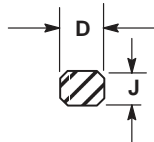
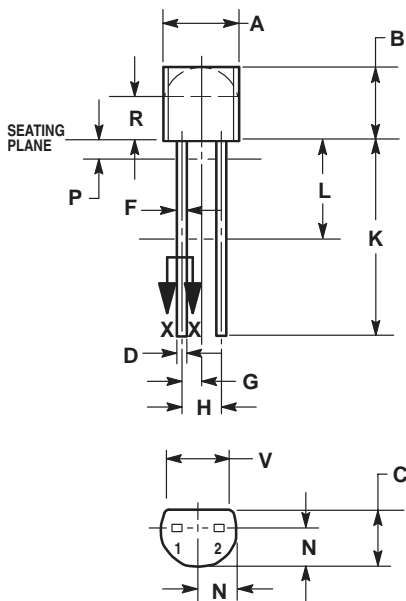

SECTION X-X

NOTES:

1. DIMENSIONING AND TOLERANCING PER ANSI Y14.5M, 1982.
2. CONTROLLING DIMENSION: INCH.
3. CONTOUR OF PACKAGE BEYOND ZONE R IS UNCONTROLLED.
4. DIMENSION F APPLIES BETWEEN P AND L. DIMENSIONS D AND J APPLY BETWEEN L AND K MINIMUM. LEAD DIMENSION IS UNCONTROLLED IN P AND BEYOND DIM K MINIMUM.

DIM	INCHES		MILLIMETERS	
	MIN	MAX	MIN	MAX
A	0.175	0.205	4.45	5.21
B	0.170	0.210	4.32	5.33
C	0.125	0.165	3.18	4.49
D	0.016	0.022	0.41	0.56
F	0.016	0.019	0.407	0.482
G	0.050 BSC		1.27 BSC	
H	0.100 BSC		3.54 BSC	
J	0.014	0.016	0.36	0.41
K	0.500	—	12.70	—
L	0.250	—	6.35	—
N	0.080	0.105	2.03	2.66
P	—	0.050	—	1.27
R	0.115	—	2.93	—
V	0.135	—	3.43	—

STYLE 1:
PIN 1. ANODE
2. CATHODE

CASE 182-02
(T0-226AC) TO-92
PLASTIC

PACKAGE OUTLINE DIMENSIONS (continued)

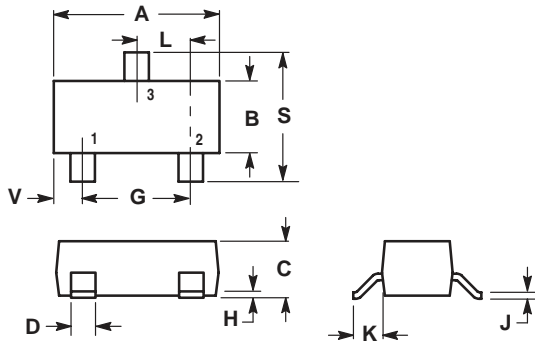

- NOTES:
1. DIMENSIONING AND TOLERANCING PER ANSI Y14.5M, 1982.
 2. CONTROLLING DIMENSION: INCH.
 3. MAXIMUM LEAD THICKNESS INCLUDES LEAD FINISH THICKNESS. MINIMUM LEAD THICKNESS IS THE MINIMUM THICKNESS OF BASE MATERIAL.

DIM	INCHES		MILLIMETERS	
	MIN	MAX	MIN	MAX
A	0.1102	0.1197	2.80	3.04
B	0.0472	0.0551	1.20	1.40
C	0.0350	0.0440	0.89	1.11
D	0.0150	0.0200	0.37	0.50
G	0.0701	0.0807	1.78	2.04
H	0.0005	0.0040	0.013	0.100
J	0.0034	0.0070	0.085	0.177
K	0.0140	0.0285	0.35	0.69
L	0.0350	0.0401	0.89	1.02
S	0.0830	0.1039	2.10	2.64
V	0.0177	0.0236	0.45	0.60

STYLE 6:
PIN 1. BASE
2. EMITTER
3. COLLECTOR

STYLE 8:
PIN 1. ANODE
2. NO CONNECTION
3. CATHODE

STYLE 9:
PIN 1. ANODE
2. ANODE
3. CATHODE

STYLE 10:
PIN 1. DRAIN
2. SOURCE
3. GATE

STYLE 11:
PIN 1. ANODE
2. CATHODE
3. CATHODE-ANODE

STYLE 12:
PIN 1. CATHODE
2. CATHODE
3. ANODE

STYLE 18:
PIN 1. NO CONNECTION
2. CATHODE
3. ANODE

STYLE 19:
PIN 1. CATHODE
2. ANODE
3. CATHODE-ANODE

STYLE 21:
PIN 1. GATE
2. SOURCE
3. DRAIN

**CASE 318-08
(TO-236AB) SOT-23
PLASTIC**

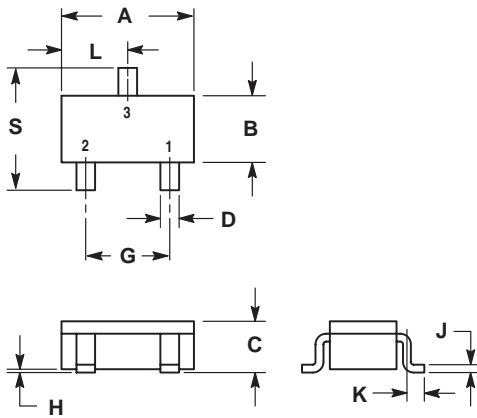

- NOTES:
1. DIMENSIONING AND TOLERANCING PER ANSI Y14.5M, 1982.
 2. CONTROLLING DIMENSION: MILLIMETER.

DIM	MILLIMETERS		INCHES	
	MIN	MAX	MIN	MAX
A	2.70	3.10	0.1063	0.1220
B	1.30	1.70	0.0512	0.0669
C	1.00	1.30	0.0394	0.0511
D	0.35	0.50	0.0138	0.0196
G	1.70	2.10	0.0670	0.0826
H	0.013	0.100	0.0005	0.0040
J	0.09	0.18	0.0034	0.0070
K	0.20	0.60	0.0079	0.0236
L	1.25	1.65	0.0493	0.0649
S	2.50	3.00	0.0985	0.1181

STYLE 1:
PIN 1. EMITTER
2. BASE
3. COLLECTOR

STYLE 2:
PIN 1. N.C.
2. ANODE
3. CATHODE

STYLE 3:
PIN 1. ANODE
2. ANODE
3. CATHODE

STYLE 4:
PIN 1. N.C.
2. CATHODE
3. ANODE

STYLE 5:
PIN 1. CATHODE
2. CATHODE
3. ANODE

**CASE 318D-04
SC-59**

PACKAGE OUTLINE DIMENSIONS (continued)

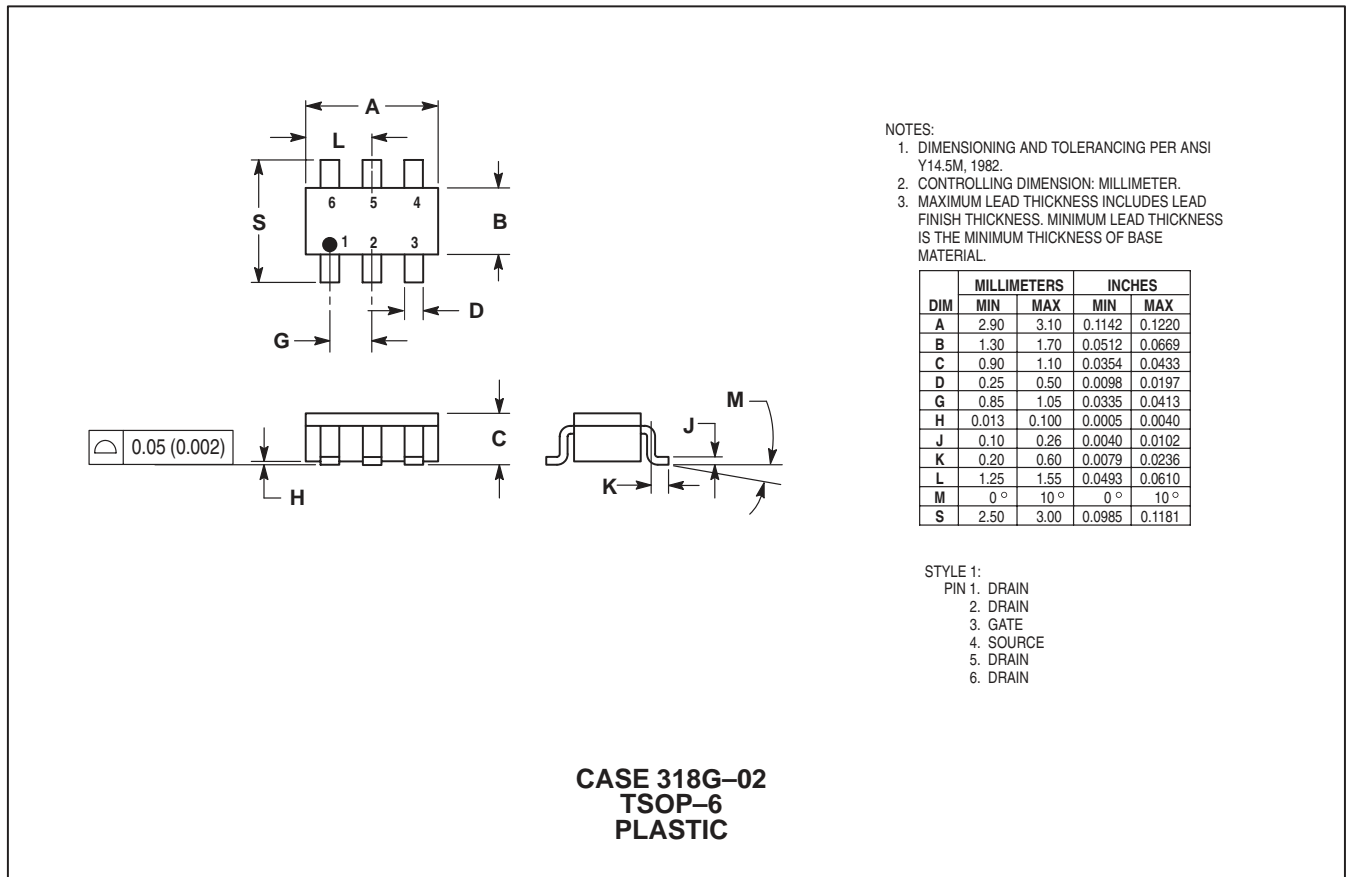
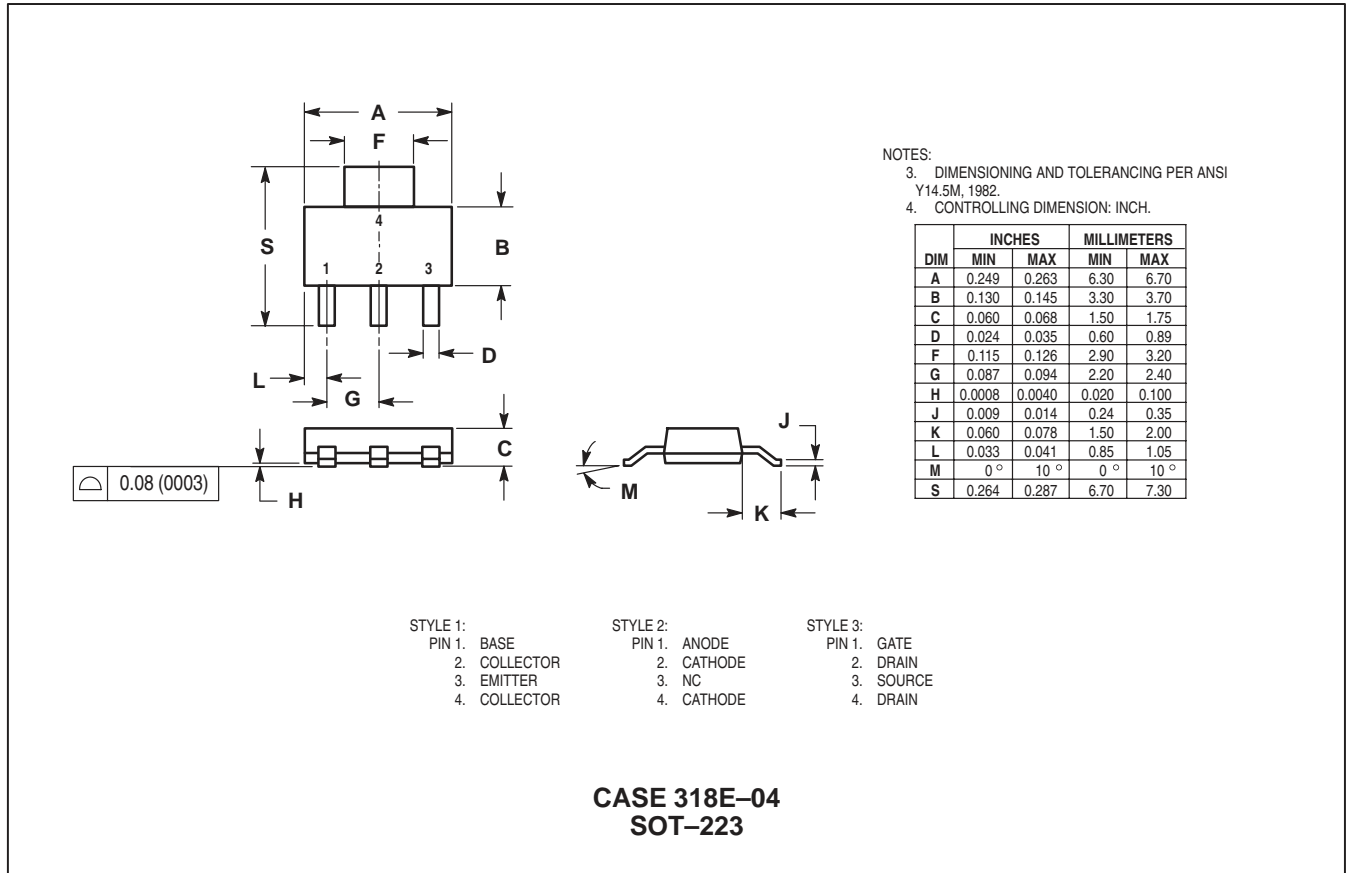

PACKAGE OUTLINE DIMENSIONS (continued)

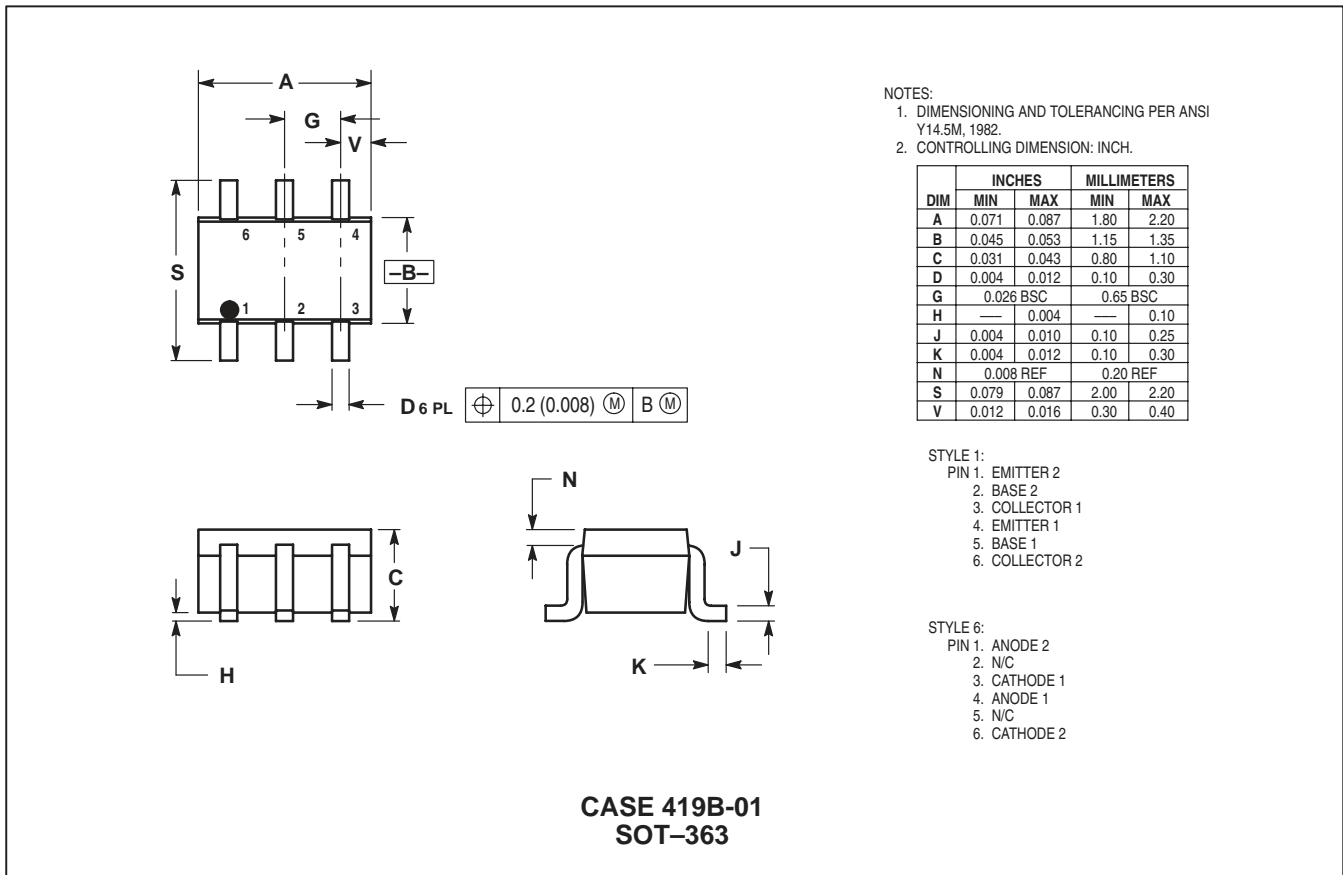
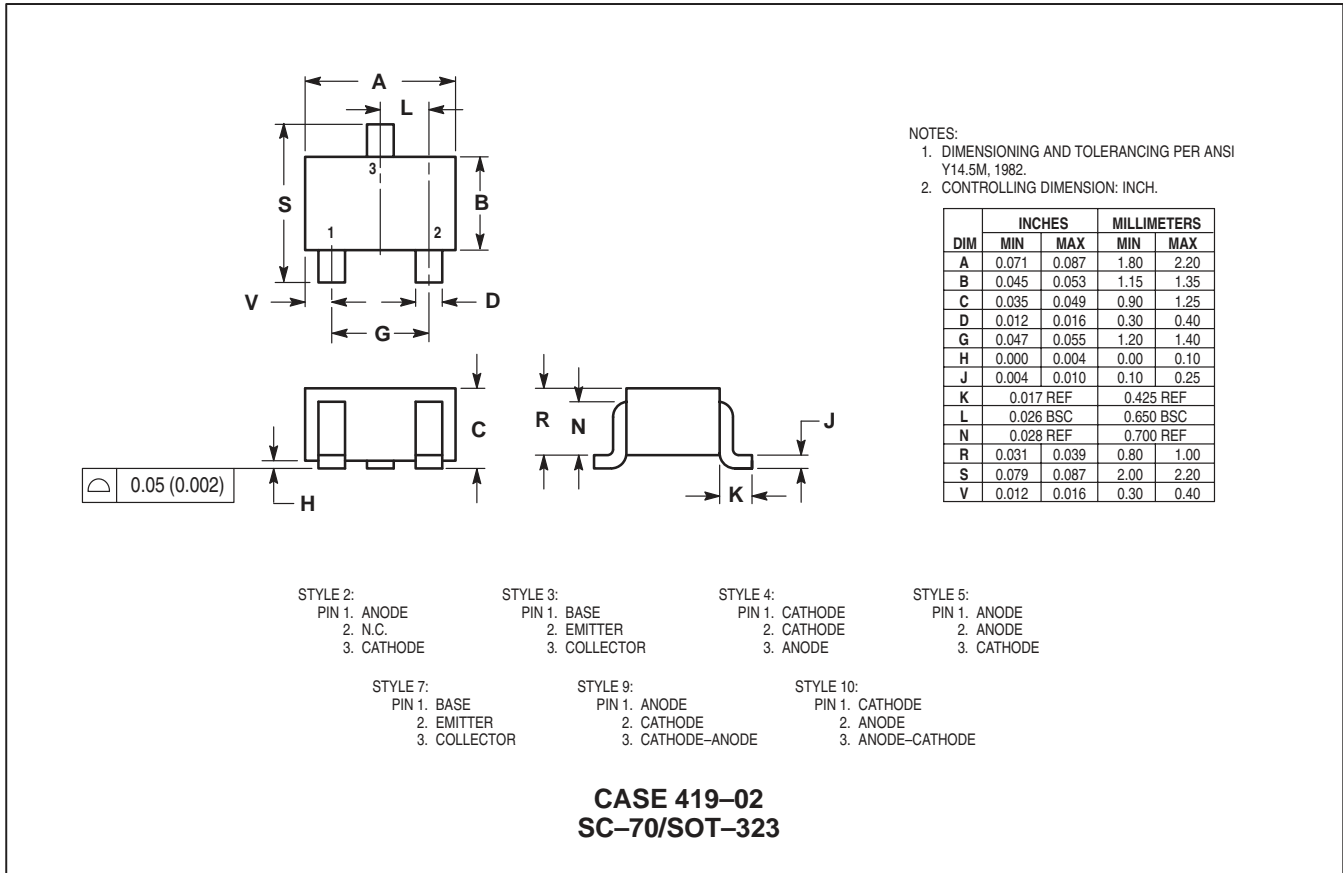

PACKAGE OUTLINE DIMENSIONS (continued)

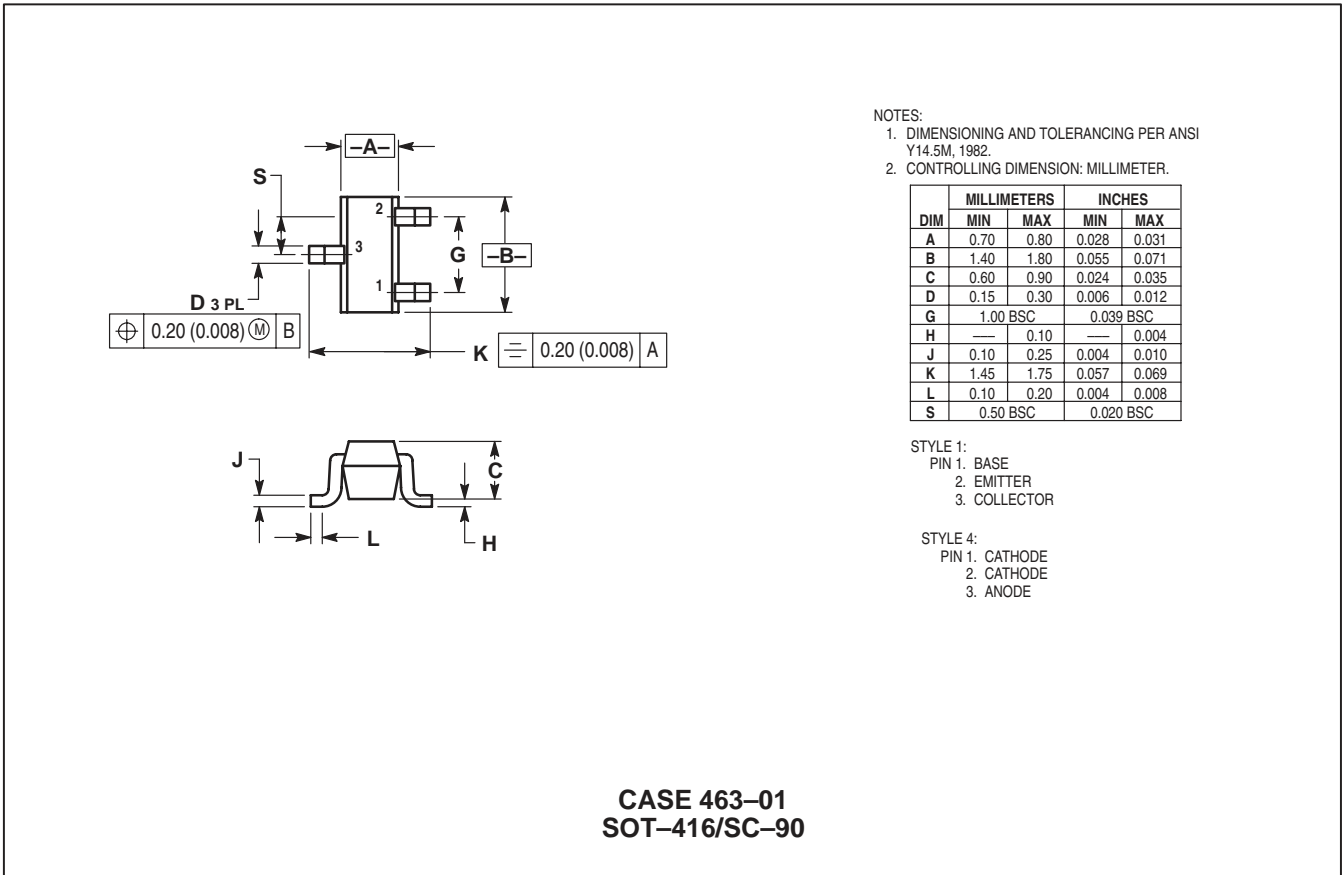
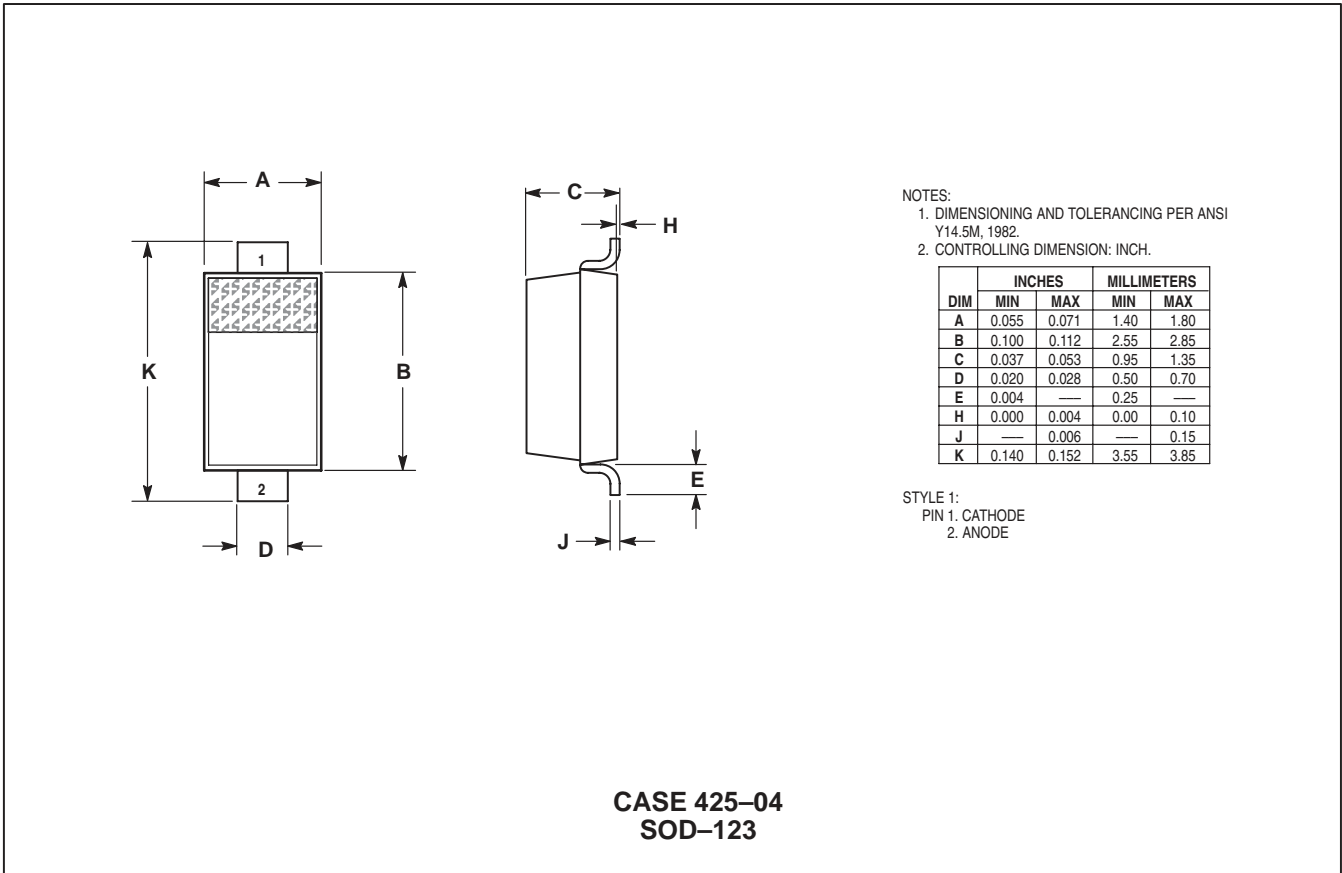

PACKAGE OUTLINE DIMENSIONS (continued)

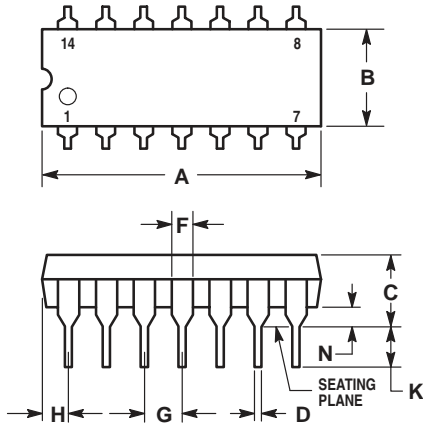

NOTES:

- LEADS WITHIN 0.13 (0.005) RADIUS OF TRUE POSITION AT SEATING PLANE AT MAXIMUM MATERIAL CONDITION.
- DIMENSION L TO CENTER OF LEADS WHEN FORMED PARALLEL.
- DIMENSION B DOES NOT INCLUDE MOLD FLASH.
- ROUNDED CORNERS OPTIONAL.

DIM	INCHES		MILLIMETERS	
	MIN	MAX	MIN	MAX
A	0.715	0.770	18.16	19.56
B	0.240	0.260	6.10	6.60
C	0.145	0.185	3.69	4.69
D	0.015	0.021	0.38	0.53
F	0.040	0.070	1.02	1.78
G	0.100 BSC		2.54 BSC	
H	0.052	0.095	1.32	2.41
J	0.008	0.015	0.20	0.38
K	0.115	0.135	2.92	3.43
L	0.300 BSC		7.62 BSC	
M	0° - 10°		0° - 10°	
N	0.015	0.039	0.39	1.01

CASE 646-06
14-PIN DIP
PLASTIC

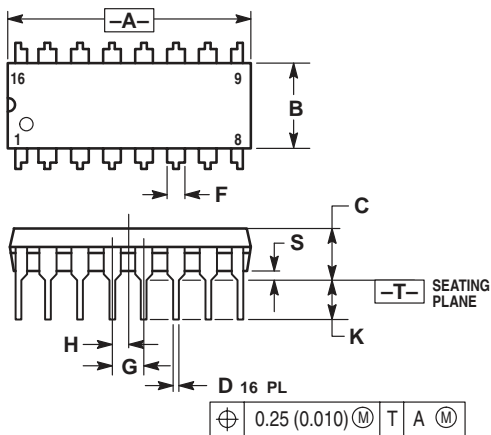

NOTES:

- DIMENSIONING AND TOLERANCING PER ANSI Y14.5M, 1982.
- CONTROLLING DIMENSION: INCH.
- DIMENSION L TO CENTER OF LEADS WHEN FORMED PARALLEL.
- DIMENSION B DOES NOT INCLUDE MOLD FLASH.
- ROUNDED CORNERS OPTIONAL.

DIM	INCHES		MILLIMETERS	
	MIN	MAX	MIN	MAX
A	0.740	0.770	18.80	19.55
B	0.250	0.270	6.35	6.85
C	0.145	0.175	3.69	4.44
D	0.015	0.021	0.39	0.53
F	0.040	0.70	1.02	1.77
G	0.100 BSC		2.54 BSC	
H	0.050 BSC		1.27 BSC	
J	0.008	0.015	0.21	0.38
K	0.110	0.130	2.80	3.30
L	0.295	0.305	7.50	7.74
M	0° - 10°		0° - 10°	
S	0.020	0.040	0.51	1.01

CASE 648-08
16-PIN DIP
PLASTIC

PACKAGE OUTLINE DIMENSIONS (continued)

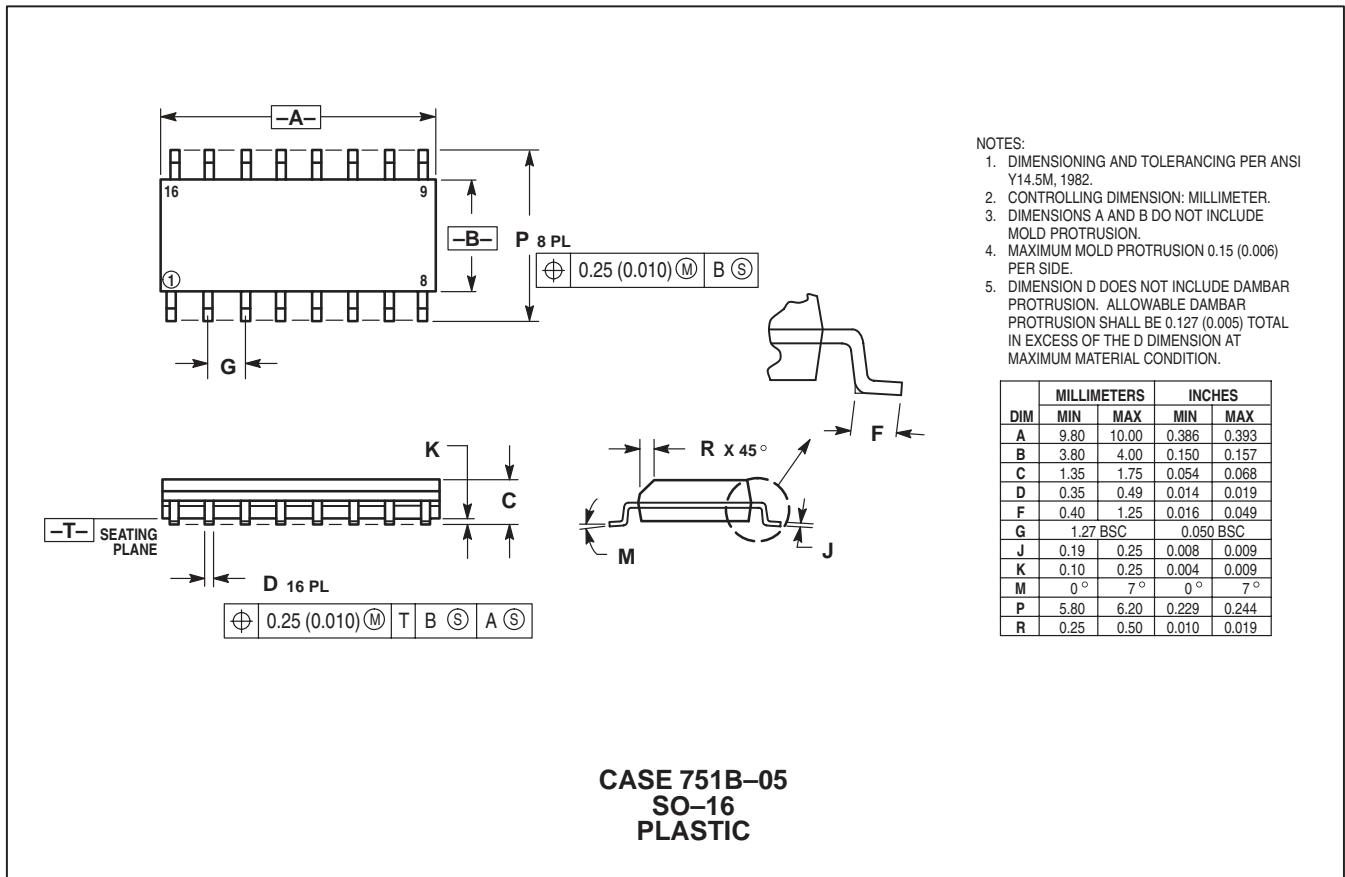
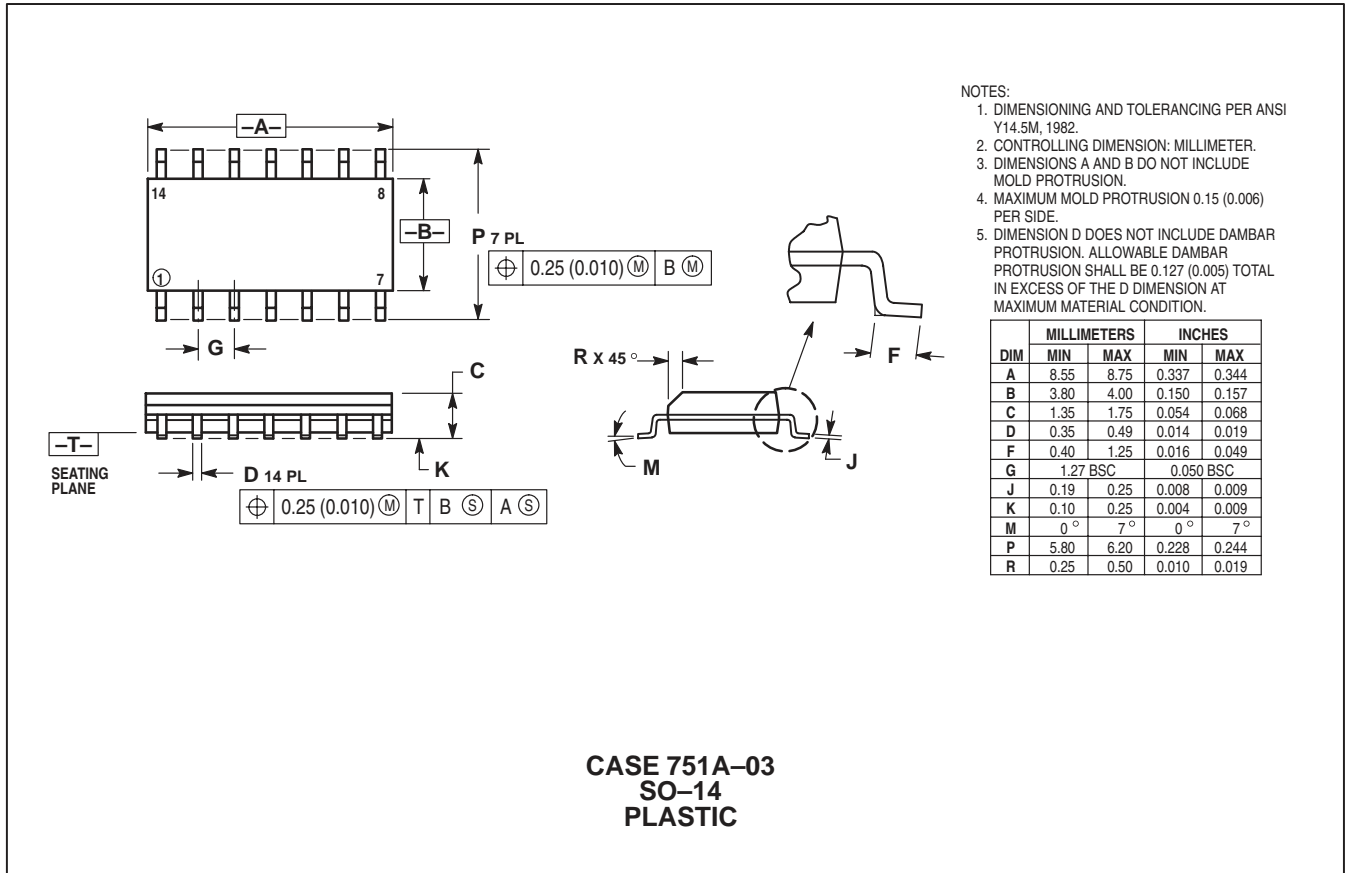

OUTGOING QUALITY

The Average Outgoing Quality (AOQ) refers to the number of devices per million that are outside the specification limits at the time of shipment. Motorola has established Six Sigma goals to improve its outgoing quality and will continue its "error free performance" focus to achieve its goal of zero parts per million (PPM) outgoing quality. Motorola's present quality level has led to vendor certification programs with many of its customers. These programs ensure a level of quality which allows the customer either to reduce or eliminate the need for incoming inspections.

AVERAGE OUTGOING QUALITY (AOQ) CALCULATION

$$AOQ = (\text{Process Average}) \bullet (\text{Probability of Acceptance}) \bullet (10^6) \text{ (PPM)}$$

- Process Average = $\frac{\text{Total Projected Reject Devices}}{\text{Total Number of Devices}}$
- Projected Reject Devices = $\frac{\text{Defects in Sample}}{\text{Sample Size}} \bullet \text{Lot Size}$
- Total Number of Devices = Sum of units in each submitted lot
- Probability of Acceptance = $1 \pm \frac{\text{Number of Lots Rejected}}{\text{Number of Lots Tested}}$
- 10^6 = Conversion to parts per million (PPM)

RELIABILITY DATA ANALYSIS

Reliability is the probability that a semiconductor device will perform its specified function in a given environment for a specified period. In other words, reliability is quality over time and environmental conditions. The most frequently used reliability measure for semiconductor devices is the failure rate (λ). The failure rate is obtained by dividing the number of failures observed by the product of the number of devices on test and the interval in hours, usually expressed as percent per thousand hours or failures per billion device hours (FITS). This is called a point estimate because it is obtained from observations on a portion (sample) of the population of devices.

To project from the sample to the population in general, one must establish confidence intervals. The application of confidence intervals is a statement of how "confident" one is that the sample failure rate approximates that for the population. To obtain failure rates at different confidence levels, it is necessary to make use of specific probability distributions. The chi-square (χ^2) distribution that relates observed and expected frequencies of an event is frequently used to establish confidence intervals. The relationship between failure rate and the chi-square distribution is as follows:

$$\lambda = \frac{\chi^2(\alpha, \text{d. f.})}{2t}$$

where:

- λ = failure rate
- χ^2 = chi-square function
- α = (100 – confidence level) / 100
- d.f. = degrees of freedom = $2r + 2$
- r = number of failures
- t = device hours

Chi-square values for 60% and 90% confidence intervals for up to 12 failures are shown in Table 1-1.

Table 1-1 – Chi-Square Table

Chi-Square Distribution Function			
60% Confidence Level		90% Confidence Level	
No. Fails	χ^2 Quantity	No. Fails	χ^2 Quantity
0	1.833	0	4.605
1	4.045	1	7.779
2	6.211	2	10.645
3	8.351	3	13.362
4	10.473	4	15.987
5	12.584	5	18.549
6	14.685	6	21.064
7	16.780	7	23.542
8	18.868	8	25.989
9	20.951	9	28.412
10	23.031	10	30.813
11	25.106	11	33.196
12	27.179	12	35.563

The failure rate of semiconductor devices is inherently low. As a result, the industry uses a technique called accelerated testing to assess the reliability of semiconductors. During accelerated tests, elevated stresses are used to produce, in a short period, the same failure mechanisms as would be observed under normal use conditions. The objective of this testing is to identify these failure mechanisms and eliminate them as a cause of failure during the useful life of the product.

Temperature, relative humidity, and voltage are the most frequently used stresses during accelerated testing. Their relationship to failure rates has been shown to follow an Eyring type of equation of the form:

$$\lambda = A \exp(\phi/kT) \bullet \exp(B/RH) \bullet \exp(CE)$$

Where A, B, C, ϕ , and k are constants, more specifically B, C, and ϕ are numbers representing the apparent energy at which various failure mechanisms occur. These are called activation energies. "T" is the temperature, "RH" is the relative humidity, and "E" is the electric field. The most familiar form of this equation (shown on following page) deals with the first exponential term that shows an Arrhenius type relationship of the failure rate versus the junction temperature of semiconductors. The junction temperature is related to the ambient temperature through the thermal resistance and power dissipation. Thus, we can test devices near their maximum junction temperatures, analyze the failures to assure that they are the types that are accelerated by temperature and then by applying known acceleration factors, estimate the failure rates for lower junction.

The table on the following page shows observed activation energies with references.

**Table 1-2 – Time Dependent Failure Mechanisms in Semiconductor Devices
(Applicable to Discrete and Integrated Circuits)**

Device Association	Process	Relevant Factors	Accelerating Factors	Typical Activation Energy in eV	Model	Reference
Silicon Oxide Silicon-Silicon Oxide Interface	Surface Charges Inversion, Accumulation	Mobile Ions E/V, T	T, V	1.0	Fitch, et al. Peck	1A 2
	Oxide Pinholes	E/V, T	E, T	0.7–1.0 (Bipolar) 1.0 (Bipolar)	1984 WRS Hokari, et al.	18 5
	Dielectric Breakdown (TDDB)	E/V, T	E, T	0.3–0.4 (MOS) 0.3 (MOS)	Domangue, et al. Crook, D.L.	3 4
	Charge Loss	E, T	E, T	0.8 (MOS) EPROM	Gear, G.	11
Metallization	Electromigration	T, J	J, T	1.0 Large grain Al (glassivated)	Nanda, et al.	6
		Grain Size		0.5 Small grain Al	Black, J.R.	7
		Doping		0.7 Cu–Al/Cu–Si–Al (sputtered)	Black, J.R.	12
	Corrosion Chemical Galvanic Electrolytic	Contamination	H, E/V, T	0.6–0.7 (for electrolysis) E/V may have thresholds	Lycoudes, N.E.	8
Bond and Other Mechanical Interfaces	Intermetallic Growth	T, Impurities Bond Strength	T	1.0 (Au/Al)	Fitch, W.T	9
Various Water Fab, Assembly, and Silicon Defects	Metal Scratches Mask Defects, etc. Silicon Defects	T, V	T, V	0.5–0.7 eV	Howes, et al.	10
				0.5 eV	MMPD	13

V = voltage; E = electric field; T = temperature; J = current density; H = humidity

NO. REFERENCE

<p>1A 1.0 eV activation for leakage type failures. Fitch, W.T.; Greer, P.; Lycoudes, N.; "Data to Support 0.001%/1000 Hours for Plastic I/C's." Case study on linear product shows 0.914 eV activation energy which is within experimental error of 0.9 to 1.3 eV activation energies for reversible leakage (inversion) failures reported in the literature.</p> <p>1B 0.7 To 1.0 eV for oxide defect failures for bipolar structures. This is under investigation subsequent to information obtained from 1984 Wafer Reliability Symposium, especially for bipolar capacitors with silicon nitride as dielectric.</p> <p>2 1.0 eV activation for leakage type failures. Peck, D.S.; "New Concerns About Integrated Circuit Reliability" 1978 Reliability Physics Symposium.</p> <p>3 0.36 eV for dielectric breakdown for MOS gate structures. Domangue, E.; Rivera, R.; Shedard, C.; "Reliability Prediction Using Large MOS Capacitors", 1984 Reliability Physics Symposium.</p> <p>4 0.3 eV for dielectric breakdown. Crook, D.L.; "Method of Determining Reliability Screens for Time Dependent Dielectric Breakdown", 1979 Reliability Physics Symposium.</p> <p>5 1.0 eV for dielectric breakdown. Hokari, Y.; et al.; IEDM Technical Digest, 1982.</p>	<p>6 1.0 eV for large grain Al–Si (compared to line width). Nanda, Vangard, Gj–P; Black, J.R.; "Electromigration of Al–Si Alloy Films", 1978 Reliability Physics Symposium.</p> <p>7 0.5 eV Al, 0.7 eV Cu–Al small grain (compared to line width). Black, J.R.; "Current Limitation of Thin Film Conductor" 1982 Reliability Physics Symposium.</p> <p>8 0.65 eV for corrosion mechanism. Lycoudes, N.E.; "The Reliability of Plastic Microcircuits in Moist Environments", 1978 Solid State Technology.</p> <p>9 1.0 eV for open wires or high resistance bonds at the pad bond due to Au–Al intermetallics. Fitch, W.T.; "Operating Life vs Junction Temperatures for Plastic Encapsulated I/C (1.5 mil Au wire)", unpublished report.</p> <p>10 0.7 eV for assembly related defects. Howes, M.G.; Morgan, D.V.; "Reliability and Degradation, Semiconductor Devices and Circuits" John Wiley and Sons, 1981.</p> <p>11 Gear, G.; "FAMOUS PROM Reliability Studies", 1976 Reliability Physics Symposium.</p> <p>12 Black, J.R.: unpublished report.</p> <p>13 Motorola Memory Products Division; unpublished report.</p>
---	--

THERMAL RESISTANCE

Circuit performance and long-term circuit reliability are affected by die temperature. Normally, both are improved by keeping the junction temperatures low.

Electrical power dissipated in any semiconductor device is a source of heat. This heat source increases the temperature of the die about some reference point, normally the ambient temperature of 25°C in still air. The temperature increase, then, depends on the amount of power dissipated in the circuit and on the net thermal resistance between the heat source and the reference point.

The temperature at the junction depends on the packaging and mounting system's ability to remove heat generated in the circuit from the junction region to the ambient environment. The basic formula for converting power dissipation to estimated junction temperature is:

$$T_J = T_A + P_D (\theta_{JC} + \theta_{CA}) \quad (1)$$

or

$$T_J = T_A + P_D \theta_{JA} \quad (2)$$

where:

T_J = maximum junction temperature

T_A = maximum ambient temperature

P_D = calculated maximum power dissipation, including effects of external loads when applicable

θ_{JC} = average thermal resistance, junction to case

θ_{CA} = average thermal resistance, case to ambient

θ_{JA} = average thermal resistance, junction to ambient

This Motorola recommended formula has been approved by RADC and DESC for calculating a "practical" maximum operating junction temperature for MIL-M-38510 devices.

Only two terms on the right side of equation (1) can be varied by the user, the ambient temperature and the device case-to-ambient thermal resistance, θ_{CA} . (To some extent the device power dissipation can also be controlled, but under recommended use the supply voltage and loading dictate a

fixed power dissipation.) Both system air flow and the package mounting technique affect the θ_{CA} thermal resistance term. θ_{JC} is essentially independent of air flow and external mounting method, but is sensitive to package material, die bonding method, and die area.

For applications where the case is held at essentially a fixed temperature by mounting on a large or temperature controlled heat sink, the estimated junction temperature is calculated by:

$$T_J = T_C + P_D \theta_{JC} \quad (3)$$

where T_C = maximum case temperature and the other parameters are as previously defined.

AIR FLOW

Air flow over the packages (due to a decrease in θ_{JC}) reduces the thermal resistance of the package, therefore permitting a corresponding increase in power dissipation without exceeding the maximum permissible operating junction temperature.

For thermal resistance values for specific packages, see the Motorola Data Book or Design Manual for the appropriate device family or contact your local Motorola sales office.

ACTIVATION ENERGY

Determination of activation energies is accomplished by testing randomly selected samples from the same population at various stress levels and comparing failure rates due to the same failure mechanism. The activation energy is represented by the slope of the curve relating to the natural logarithm of the failure rate to the various stress levels.

In calculating failure rates, the comprehensive method is to use the specific activation energy for each failure mechanism applicable to the technology and circuit under consideration. A common alternative method is to use a single activation energy value for the "expected" failure mechanism(s) with the lowest activation energy.

RELIABILITY STRESS TESTS

The following are brief descriptions of the reliability tests commonly used in the reliability monitoring program. Not all of the tests listed are performed by each product division. Other tests may be performed when appropriate.

AUTOCLAVE (aka, PRESSURE COOKER)

Autoclave is an environmental test which measures device resistance to moisture penetration and the resultant effect of galvanic corrosion. Autoclave is a highly accelerated and destructive test.

Typical Test Conditions: $T_A = 121^\circ\text{C}$, $\text{rh} = 100\%$, $p = 1$ atmosphere (15 psig), $t = 24$ to 96 hours

Common Failure Modes: Parametric shifts, high leakage and/or catastrophic

Common Failure Mechanisms: Die corrosion or contaminants such as foreign material on or within the package materials. Poor package sealing.

HIGH HUMIDITY HIGH TEMPERATURE BIAS (H3TB, H3TRB, or THB)

This is an environmental test designed to measure the moisture resistance of plastic encapsulated devices. A bias is applied to create an electrolytic cell necessary to accelerate corrosion of the die metallization. With time, this is a catastrophically destructive test.

Typical Test Conditions: $T_A = 85^\circ\text{C}$ to 95°C , $\text{rh} = 85\%$ to 95% , Bias = 80% to 100% of Data Book max. rating, $t = 96$ to 1750 hours

Common Failure Modes: Parametric shifts, high leakage and/or catastrophic

Common Failure Mechanisms: Die corrosion or contaminants such as foreign material on or within the package materials. Poor package sealing.

HIGH TEMPERATURE GATE BIAS (HTGB)

This test is designed to electrically stress the gate oxide under a bias condition at high temperature.

Typical Test Conditions: $T_A = 150^\circ\text{C}$, Bias = 80% of Data Book max. rating, $t = 120$ to 1000 hours

Common Failure Modes: Parametric shifts in gate leakage and gate threshold voltage

Common Failure Mechanisms: Random oxide defects and ionic contamination

Military Reference: MIL-STD-750, Method 1042

HIGH TEMPERATURE REVERSE BIAS (HTRB)

The purpose of this test is to align mobile ions by means of temperature and voltage stress to form a high-current leakage path between two or more junctions.

Typical Test Conditions: $T_A = 85^\circ\text{C}$ to 150°C , Bias = 80% to 100% of Data Book max. rating, $t = 120$ to 1000 hours

Common Failure Modes: Parametric shifts in leakage and gain

Common Failure Mechanisms: Ionic contamination on the surface or under the metallization of the die

Military Reference: MIL-STD-750, Method 1039

HIGH TEMPERATURE STORAGE LIFE (HTSL)

High temperature storage life testing is performed to accelerate failure mechanisms which are thermally activated through the application of extreme temperatures

Typical Test Conditions: $T_A = 70^\circ\text{C}$ to 200°C , no bias, $t = 24$ to 2500 hours

Common Failure Modes: Parametric shifts in leakage and gain

Common Failure Mechanisms: Bulk die and diffusion defects

Military Reference: MIL-STD-750, Method 1032

INTERMITTENT OPERATING LIFE (IOL)

The purpose of this test is the same as SSOL in addition to checking the integrity of both wire and die bonds by means of thermal stressing

Typical Test Conditions: $T_A = 25^\circ\text{C}$, $P_d =$ Data Book maximum rating, $T_{\text{ON}} = T_{\text{OFF}} = \Delta$ of 50°C to 100°C , $t = 42$ to 30000 cycles

Common Failure Modes: Parametric shifts and catastrophic

Common Failure Mechanisms: Foreign material, crack and bulk die defects, metallization, wire and die bond defects

Military Reference: MIL-STD-750, Method 1037

MECHANICAL SHOCK

This test is used to determine the ability of the device to withstand a sudden change in mechanical stress due to abrupt changes in motion as seen in handling, transportation, or actual use.

Typical Test Conditions: Acceleration = 1500 g's, Orientation = X_1, Y_1, Y_2 plane, $t = 0.5$ msec, Blows = 5

Common Failure Modes: Open, short, excessive leakage, mechanical failure

Common Failure Mechanisms: Die and wire bonds, cracked die, package defects

Military Reference: MIL-STD-750, Method 2015

MOISTURE RESISTANCE

The purpose of this test is to evaluate the moisture resistance of components under temperature/humidity conditions typical of tropical environments.

Typical Test Conditions: $T_A = -10^\circ\text{C}$ to 65°C , $rh = 80\%$ to 98% , $t = 24$ hours/cycles, cycle = 10

Common Failure Modes: Parametric shifts in leakage and mechanical failure

Common Failure Mechanisms: Corrosion or contaminants on or within the package materials. Poor package sealing

Military Reference: MIL-STD-750, Method 1021

SOLDERABILITY

The purpose of this test is to measure the ability of the device leads/terminals to be soldered after an extended period of storage (shelf life).

Typical Test Conditions: Steam aging = 8 hours, Flux = R, Solder = Sn60, Sn63

Common Failure Modes: Pin holes, dewetting, nonwetting

Common Failure Mechanisms: Poor plating, contaminated leads

Military Reference: MIL-STD-750, Method 2026

SOLDER HEAT

This test is used to measure the ability of a device to withstand the temperatures as may be seen in wave soldering operations. Electrical testing is the endpoint criterion for this stress.

Typical Test Conditions: Solder Temperature = 260°C , $t = 10$ seconds

Common Failure Modes: Parameter shifts, mechanical failure

Common Failure Mechanisms: Poor package design

Military Reference: MIL-STD-750, Method 2031

STEADY STATE OPERATING LIFE (SSOL)

The purpose of this test is to evaluate the bulk stability of the die and to generate defects resulting from manufacturing aberrations that are manifested as time and stress-dependent failures.

Typical Test Conditions: $T_A = 25^\circ\text{C}$, $P_D =$ Data Book maximum rating, $t = 16$ to 1000 hours

Common Failure Modes: Parametric shifts and catastrophic

Common Failure Mechanisms: Foreign material, crack die, bulk die, metallization, wire and die bond defects

Military Reference: MIL-STD-750, Method 1026

TEMPERATURE CYCLING (AIR TO AIR)

The purpose of this test is to evaluate the ability of the device to withstand both exposure to extreme temperatures and transitions between temperature extremes. This testing will also expose excessive thermal mismatch between materials.

Typical Test Conditions: $T_A = -65^\circ\text{C}$ to 200°C , cycle = 10 to 4000

Common Failure Modes: Parametric shifts and catastrophic

Common Failure Mechanisms: Wire bond, cracked or lifted die and package failure

Military Reference: MIL-STD-750, Method 1051

THERMAL SHOCK (LIQUID TO LIQUID)

The purpose of this test is to evaluate the ability of the device to withstand both exposure to extreme temperatures and sudden transitions between temperature extremes. This testing will also expose excessive thermal mismatch between materials.

Typical Test Conditions: $T_A = 0^\circ\text{C}$ to 100°C , cycle = 20 to 300

Common Failure Modes: Parametric shifts and catastrophic

Common Failure Mechanisms: Wire bond, cracked or lifted die and package failure

Military Reference: MIL-STD-750, Method 1056

VARIABLE FREQUENCY VIBRATION

This test is used to examine the ability of the device to withstand deterioration due to mechanical resonance.

Typical Test Conditions: Peak acceleration = 20 g's, Frequency range = 20 Hz to KHz, $t = 48$ minutes

Common Failure Modes: Open, short, excessive leakage, mechanical failure

Common Failure Mechanisms: Die and wire bonds, cracked die, package defects

Military Reference: MIL-STD-750, Method 2056

STATISTICAL PROCESS CONTROL

Communication Power & Signal Technologies Group (CPSTG) is continually pursuing new ways to improve product quality. Initial design improvement is one method that can be used to produce a superior product. Equally important to outgoing product quality is the ability to produce product that consistently conforms to specification. Process variability is the basic enemy of semiconductor manufacturing since it leads to product variability. Used in all phases of Motorola's product manufacturing, STATISTICAL PROCESS CONTROL (SPC) replaces variability with predictability. The traditional philosophy in the semiconductor industry has been adherence to the data sheet specification. Using SPC methods ensures that the product will meet specific process requirements throughout the manufacturing cycle. The emphasis is on defect prevention, not detection. Predictability through SPC methods requires the manufacturing culture to focus on constant and permanent improvements. Usually, these improvements cannot be bought with state-of-the-art equipment or automated factories. With quality in design, process, and material selection, coupled with manufacturing predictability, Motorola can produce world class products.

The immediate effect of SPC manufacturing is predictability through process controls. Product centered and distributed well within the product specification benefits Motorola with fewer rejects, improved yields, and lower cost. The direct benefit to Motorola's customers includes better incoming quality levels, less inspection time, and ship-to-stock capability. Circuit performance is often dependent on the cumulative effect of component variability. Tightly controlled component distributions give the customer greater circuit predictability. Many customers are also converting to just-in-time (JIT) delivery programs. These programs require improvements in cycle time and yield predictability achievable only through SPC techniques. The benefit derived from SPC helps the manufacturer meet the customer's expectations of higher quality and lower cost product.

Ultimately, Motorola will have Six Sigma capability on all products. This means parametric distributions will be centered within the specification limits, with a product distribution of plus or minus Six Sigma about mean. Six Sigma capability, shown graphically in Figure 1, details the benefit in terms of yield and outgoing quality levels. This compares a centered distribution versus a 1.5 sigma worst case distribution shift.

New product development at Motorola requires more robust design features that make them less sensitive to minor variations in processing. These features make the implementation of SPC much easier.

A complete commitment to SPC is present throughout Motorola. All managers, engineers, production operators, supervisors, and maintenance personnel have received multiple training courses on SPC techniques. Manufacturing has identified 22 wafer processing and 8 assembly steps considered critical to the processing of semiconductor products. Processes controlled by SPC methods that have shown significant improvement are in the diffusion, photolithography, and metallization areas.

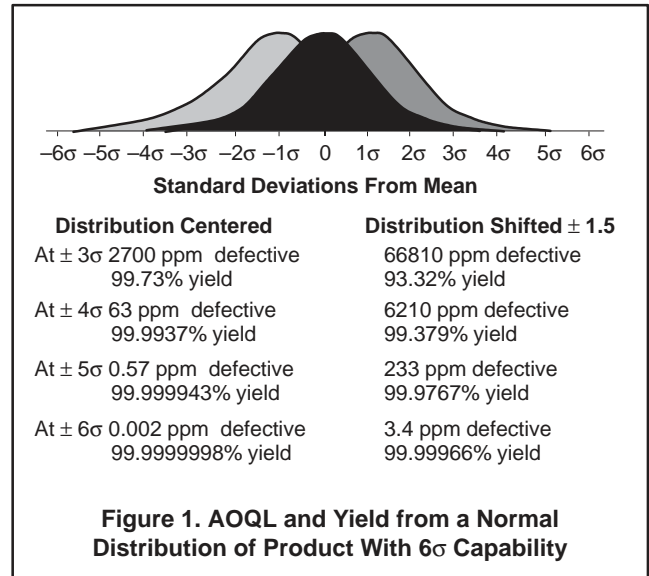

To better understand SPC principles, brief explanations have been provided. These cover process capability, implementation, and use.

PROCESS CAPABILITY

One goal of SPC is to ensure a process is **CAPABLE**. Process capability is the measurement of a process to produce products consistently to specification requirements. The purpose of a process capability study is to separate the inherent **RANDOM VARIABILITY** from **ASSIGNABLE CAUSES**. Once completed, steps are taken to identify and eliminate the most significant assignable causes. Random variability is generally present in the system and does not fluctuate. Sometimes, the random variability is due to basic limitations associated with the machinery, materials, personnel skills, or manufacturing methods. Assignable cause inconsistencies relate to time variations in yield, performance, or reliability.

Traditionally, assignable causes appear to be random due to the lack of close examination or analysis. Figure 2 shows the impact on predictability that assignable cause can have. Figure 3 shows the difference between process control and process capability.

A process capability study involves taking periodic samples from the process under controlled conditions. The performance characteristics of these samples are charted against time. In time, assignable causes can be identified and engineered out. Careful documentation of the process is the key to accurate diagnosis and successful removal of the assignable causes. Sometimes, the assignable causes will remain unclear, requiring prolonged experimentation.

Elements which measure process variation control and capability are Cp and Cpk, respectively. Cp is the specification width divided by the process width or $Cp = (\text{specification width}) / 6\sigma$. Cpk is the absolute value of the closest specification value to the mean, minus the mean, divided by half the process width or $Cpk = |\text{closest specification} - \bar{x}| / 3\sigma$.

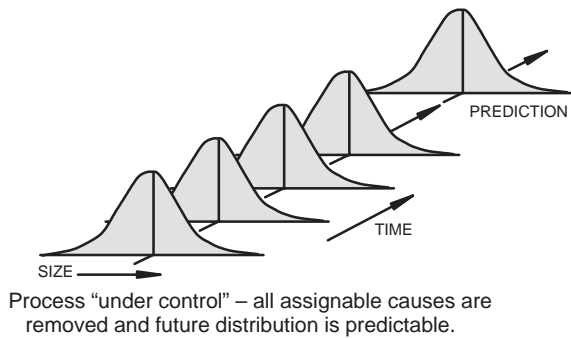

Figure 2. Impact of Assignable Causes on Process Predictable

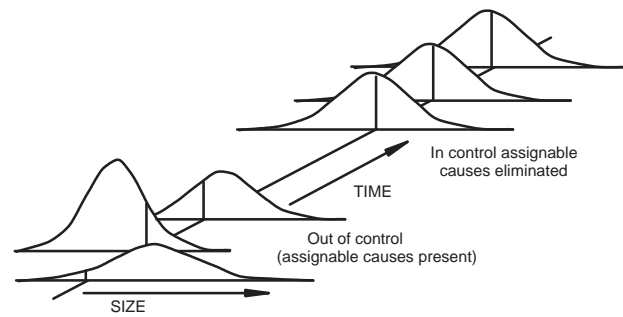

Figure 3. Difference Between Process Control and Process Capability

At Motorola, for critical parameters, the process capability is acceptable with a $Cpk = 1.50$ with continual improvement our goal. The desired process capability is a $Cpk = 2$ and the ideal is a $Cpk = 5$. Cpk , by definition, shows where the current production process fits with relationship to the specification limits. Off center distributions or excessive process variability will result in less than optimum conditions.

SPC IMPLEMENTATION AND USE

CPSTG uses many parameters that show conformance to specification. Some parameters are sensitive to process variations while others remain constant for a given product line. Often, specific parameters are influenced when changes to other parameters occur. It is both impractical and unnecessary to monitor all parameters using SPC methods. Only critical parameters that are sensitive to process variability are chosen for SPC monitoring. The process steps affecting these critical parameters must be identified as well. It is equally important to find a measurement in these process steps that correlates with product performance. This measurement is called a critical process parameter.

Once the critical process parameters are selected, a sample plan must be determined. The samples used for measurement are organized into **RATIONAL SUBGROUPS** of approximately two to five pieces. The subgroup size should be such that variation among the samples within the subgroup remain small. All samples must come from the same source e.g., the same mold press operator, etc. Subgroup data should

be collected at appropriate time intervals to detect variations in the process. As the process begins to show improved stability, the interval may be increased. The data collected must be carefully documented and maintained for later correlation. Examples of common documentation entries are operator, machine, time, settings, product type, etc.

Once the plan is established, data collection may begin. The data collected will generate \bar{X} and R values that are plotted with respect to time. \bar{X} refers to the mean of the values within a given subgroup, while R is the range or greatest value minus least value. When approximately 20 or more \bar{X} and R values have been generated, the average of these values is computed as follows:

$$\bar{\bar{X}} = (\bar{X}_1 + \bar{X}_2 + \bar{X}_3 + \dots) / K$$

$$\bar{R} = (R_1 + R_2 + R_3 + \dots) / K$$

where K = the number of subgroups measured.

The values of \bar{X} and R are used to create the process control chart. Control charts are the primary SPC tool used to signal a problem. Shown in Figure 4, process control charts show \bar{X} and R values with respect to time and concerning reference to upper and lower control limit values. Control limits are computed as follows:

$$R \text{ upper control limit} = UCLR = D_4 \bar{R}$$

$$R \text{ lower control limit} = LCLR = D_3 \bar{R}$$

$$\bar{X} \text{ upper control limit} = UCL\bar{X} = \bar{\bar{X}} + A_2 \bar{R}$$

$$\bar{X} \text{ lower control limit} = LCL\bar{X} = \bar{\bar{X}} - A_2 \bar{R}$$

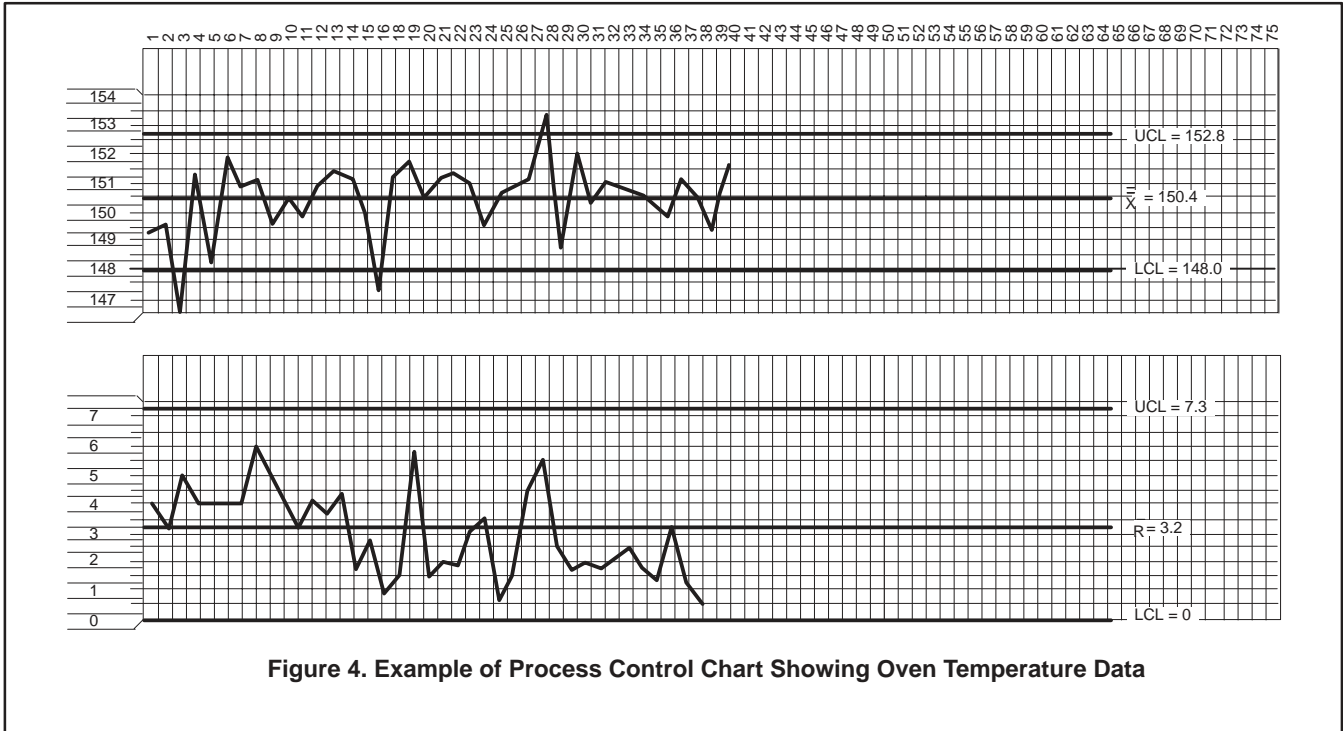

Figure 4. Example of Process Control Chart Showing Oven Temperature Data

Where D_4 , D_3 , and A_2 are constants varying by sample size, with values for sample sizes from 2 to 10 shown in the following partial table:

n	2	3	4	5	6	7	8	9	10
D_4	3.27	2.57	2.28	2.11	2.00	1.92	1.86	1.82	1.78
D_3	*	*	*	*	*	0.08	0.14	0.18	0.22
A_2	1.88	1.02	0.73	0.58	0.48	0.42	0.37	0.34	0.31

*For sample sizes below 7, the LCL_R would technically be a negative number; in those cases there is no lower control limit; this means that for a subgroup size 6, six "identical" measurements would not be unreasonable.

Control charts are used to monitor the variability of critical process parameters. The R chart shows basic problems with piece to piece variability related to the process. The X chart can often identify changes in people, machines, methods, etc. The source of the variability can be difficult to find and may require experimental design techniques to identify assignable causes.

Some general rules have been established to help determine when a process is **OUT-OF-CONTROL**. Figure 5 shows a control chart subdivided into zones A, B, and C corresponding to 3 sigma, 2 sigma, and 1 sigma limits respectively. In Figures 6 through 9 four of the tests that can be used to identify excessive variability and the presence of assignable causes are shown. As familiarity with a given process increases, more subtle tests may be employed successfully.

Once the variability is identified, the cause of the variability must be determined. Normally, only a few factors have a significant impact on the total variability of the process. The importance of correctly identifying these factors is stressed in the following example. Suppose a process variability depends on the variance of five factors A, B, C, D, and E. Each has a variance of 5, 3, 2, 1, and 0.4, respectively.

Since:

$$\sigma_{tot} = \sqrt{\sigma_A^2 + \sigma_B^2 + \sigma_C^2 + \sigma_D^2 + \sigma_E^2}$$

$$\sigma_{tot} = \sqrt{5^2 + 3^2 + 2^2 + 1^2 + (0.4)^2} = 6.3$$

If only D is identified and eliminated, then:

$$\sigma_{tot} = \sqrt{5^2 + 3^2 + 2^2 + (0.4)^2} = 6.2$$

This results in less than 2% total variability improvement. If B, C, and D were eliminated, then:

$$\sigma_{tot} = \sqrt{5^2 + (0.4)^2} = 5.02$$

This gives a considerably better improvement of 23%. If only A is identified and reduced from 5 to 2, then:

$$\sigma_{tot} = \sqrt{2^2 + 3^2 + 2^2 + 1^2 + (0.4)^2} = 4.3$$

Identifying and improving the variability from 5 to 2 yields a total variability improvement of nearly 40%.

Most techniques may be employed to identify the primary assignable cause(s). Out-of-control conditions may be correlated to documented process changes. The product may be analyzed in detail using best versus worst part comparisons or Product Analysis Lab equipment. Multi-variance analysis can be used to determine the family of variation (positional, critical, or temporal). Lastly, experiments may be run to test theoretical or factorial analysis. Whatever method is used, assignable causes must be identified and eliminated in the most expeditious manner possible.

After assignable causes have been eliminated, new control limits are calculated to provide a more challenging variability criteria for the process. As yields and variability improve, it may become more difficult to detect improvements because they become much smaller. When all assignable causes have been eliminated and the points remain within control limits for 25 groups, the process is said to be in a state of control.

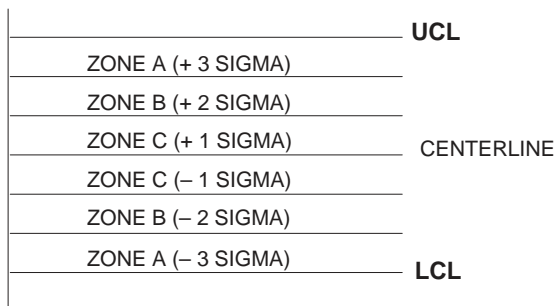

Figure 5. Control Chart Zones

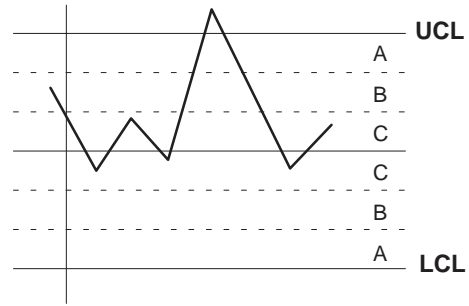

Figure 6. One Point Outside Control Limit Indicating Excessive Variability

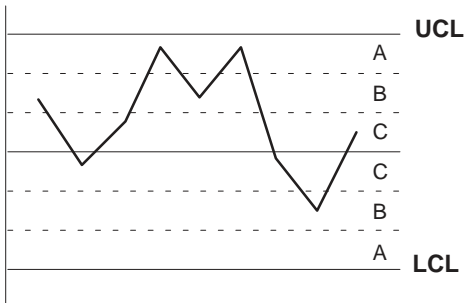

Figure 7. Two Out of Three Points in Zone A or Beyond Indicating Excessive Variability

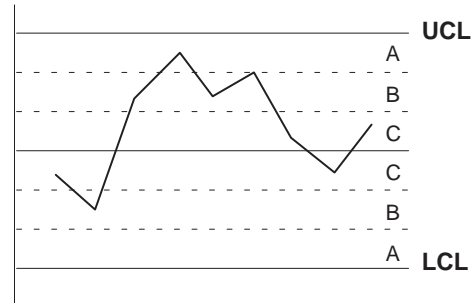

Figure 8. Four Out of Five Points in Zone B or Beyond Indicating Excessive Variability

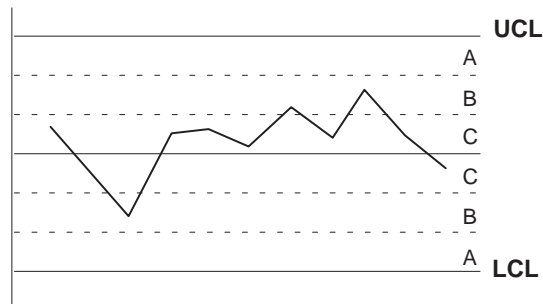

Figure 9. Seven Out of Eight Points in Zone C or Beyond Indicating Excessive Variability

SUMMARY

Motorola is committed to the use of STATISTICAL PROCESS CONTROLS. These principles, used throughout manufacturing have already resulted in many significant improvements to the processes. Continued dedication to the

SPC culture will allow Motorola to reach the Six Sigma and zero defect capability goals. SPC will further enhance the commitment to **TOTAL CUSTOMER SATISFACTION**.

REPLACEMENT DEVICES

DEVICE	REPLACEMENT	DEVICE	REPLACEMENT	DEVICE	REPLACEMENT
1N5139	MV2101	2N3053A	MPSA05	BC560B	BC560C
1N5139A	MV2101	2N3244	2N4403	BC849ALT1	BC848ALT1
1N5140	MMBV2103LT1	2N3250	2N4403	BC850ALT1	BC848ALT1
1N5140A	MMBV2103LT1	2N3251	MPS2907A	BC857CLT1	BC857ALT1
1N5141	MMBV2104LT1	2N3251A	MPS2907A	BCY70	MPS2222A
1N5141A	MMBV2104LT1	2N3467	MPSA56	BCY71	MPS2222A
1N5142	MMBV2105LT1	2N3468	MPSA56	BCY72	MPS2222A
1N5142A	MMBV2105LT1	2N3497	2N5401	BDB01D	BDB01C
1N5143	MMBV2105LT1	2N3500	2N5551	BDB02D	BDB02C
1N5143A	MMBV2105LT1	2N3501	2N5551	BDC02D	BDC01D
1N5144	MMBV2107LT1	2N3546	MPSH17	BDC05	MPSW42
1N5144A	MMBV2107LT1	2N3634	2N5401	BF244A	2N3819
1N5145	MMBV2108LT1	2N3635	2N5401	BF244B	2N3819
1N5145A	MMBV2108LT1	2N3636	MPSA92	BF245	BF245A
1N5146	MMBV2109LT1	2N3637	MPSA92	BF245A	BF245A
1N5146A	MV2109	2N3700	MPSA06	BF245B	BF245A
1N5147	MV2111	2N3799	MPSA18	BF245C	BF245A
1N5147A	MV2111	2N3947	MPS2222A	BF246A	BF245A
1N5441A	MV2101	2N3963	MPSA18	BF246B	BF245A
1N5443A	MV2103	2N3964	MPSA18	BF247B	BF245A
1N5444A	MV2104	2N4014	MPS2222A	BF256B	BF256A
1N5445A	MV2105	2N4032	MPS2907A	BF256C	BF256A
1N5449A	MV2108	2N4033	MPSA56	BF258	BF422
1N5450A	MV2109	2N4036	MPSA56	BF374	BC338
1N5451A	MV2111	2N4037	MPSA56	BF391	MPSA42
1N5452A	MV2111	2N4126	MPS4126	BF392	MPSA42
1N5453A	MV2111	2N4265	2N4264	BF492	MPSA92
1N5455A	MV2115	2N4405	MPS8599	BF493	MPSA92
2N697	MPSA20	2N4407	MPS8599	BFW43	2N5401
2N718A	MPSA05	2N4931	MPSA92	BSP20AT1	BF720T1
2N720A	MPSA06	2N5086	2N5087	BSS71	MPSA42
2N930	MPSA18	2N5668	2N3819	BSS72	MPSA42
2N930A	MPSA18	2N5669	2N3819	BSS73	MPSA42
2N956	MPSA05	2N5670	2N3819	BSS74	MPSA92
2N1613	2N4410	2N6431	MPSA42	BSS75	MPSA92
2N1711	MPSA05	2N6433	MPSA92	BSS76	MPSA92
2N1893	MPSA06	2N6516	2N6517	BSS89	BS107
2N2102	2N4410	BA582T1	MMBV3401LT1	BSV16-10	MPS2907A
2N2218A	MPS2222A	BC107	BC237	BSX20	MPS2369A
2N2219	MPS2222A	BC107A	BC237	CV12253	MPSA06
2N2219A	MPS2222A	BC107B	BC237	IRFD110	BSS123LT1
2N2222	MPS2222	BC108		IRFD113	MMBF170LT1
2N2222A	MPS2222A	BC109C	BC3338	IRFD120	BSS123LT1
2N2270	MPSA05	BC140-10	MPSW06	IRFD123	MMBF170LT1
2N2369	MPS2369	BC140-16	MPSW06	IRFD210	MMFT107T1
2N2369A	MPS2369A	BC141-10	MPSW06	IRFD213	MMFT107T1
2N2484	2N5087	BC141-16	MPSW06	IRFD220	MMFT107T1
2N2895	MPSA06	BC160-16	MPSW56	IRFD223	MMFT107T1
2N2896	2N5551	BC161-16	MPSW56	IRFD9120	BSS123LT1
2N2904	MPS2907	BC177	BC547	IRFD9123	2N7002LT1
2N2904A	MPS2907A	BC177A	BC547A	J111	J111RLRA
2N2905	MPS2907	BC177B	BC547B	J113	J113RL1
2N2905A	MPS2907A	BC238	BC238B	J203	2N5458
2N2906	MPS2907	BC309B	BC308C	J300	2N5486
2N2906A	MPS2907A	BC393	MPSA92	J305	MMBF5484LT1
2N2907	MPS2907	BC394	MPSA42	MAD130P	BAS16LT1
2N2907A	MPS2907A	BC450	MPSA92	MAD1103P	BAS16LT1
2N3019	MPSA06	BC450A	MPSA92	MAD1107P	BAS16LT1
2N3020	MPSA06	BC546A	BC546B	MAD1108P	BAS16LT1
2N3053	MPSA20	BC559	BC559B	MAD1109P	BAS16LT1

REPLACEMENT DEVICES

DEVICE	REPLACEMENT	DEVICE	REPLACEMENT	DEVICE	REPLACEMENT
MM3001	2N5551	MPS6530	MPS6530RLRM	MV2114	MV2115
MM3725	MPS2222A	MPS6531	MPS6530RLRM	MVAM108	MMBV2109LT1
MM4001	2N5401	MPS6562	MPS6651	MVAM109	MMBV2109LT1
MMAD1106	BAS16LT1	MPS6568A	MPS918	MVAM115	MMBV2109LT1
MMBF4856LT1	MMBF4391LT1	MPS6571	MPSA18	MVAM125	MMBV2109LT1
MMBF4860LT1	MMBF5457LT1	MPS6595	MPS3563	PBF259	MMBT6517LT1
MMBF5459LT1	MMBF5457LT1	MPS8093	2N4402	PBF259S	MMBT6517LT1
MMBF5486LT1	2N5486	MPSA16	MPSA17	PBF259RS	MMBT6517LT1
MMBT8599LT1	MMBT5551LT1	MPSH04	MPSH17	PBF493	MMBTA92LT1
MMBV2104LT1	MMBV2103LT1	MPSH07A	MPSH17	PBF493R	MMBTA92LT1
MMPQ3799	MMPQ3725	MPSH20	MPSH17	PBF493RS	MMBTA92LT1
MMSV3401T1	MMBV3401LT1	MPSH24	MPSH17	PBF493S	MMBT6517LT1
MPF970	MMBFJ175LT1	MPSH34	MPSH17	VN1706L	MMFT107T1
MPF971	MMBFJ175LT1	MPSH69	MPSH81		
MPF3821	MMBF5457LT1	MSA1022-BT1	MSA1022-CT1		
MPF3822	MMBF5457LT1	MSB709-ST1	MSB709-RT1		
MPF4856	MPF4391RLRA	MSB710-QT1	MSB710-RT1		
MPF4857	2N5639	MSB1218A-ST1	MSB1218A-RT1		
MPF4858	J112	MSC1621T1	MSD602-RT1		
MPF4859	2N5638RLRA	MSC2404-CT1	MSC2295-CT1		
MPF4860	2N5638RLRA	MSD1819A-ST1	MSD1819A-RT1		
MPF4861	J112	MV1620	MV2101		
MPQ6501	MPQ6502	MV1624	MMBV2103LT1		
MPS3638	MPS3638A	MV1636	MV2108		
MPS3866	BF224	MV1640	MV2109		
MPS4123	MPS4124	MV1642	MV2111		
MPS4125	MPS4126	MV1644	MV2111		
MPS4258	MPS3640	MV2103	MMBV2103LT1		
MPS5771	MPS3640	MV2107	MV2108		
MPS6520	MPS6521	MV2113	MV2111		