

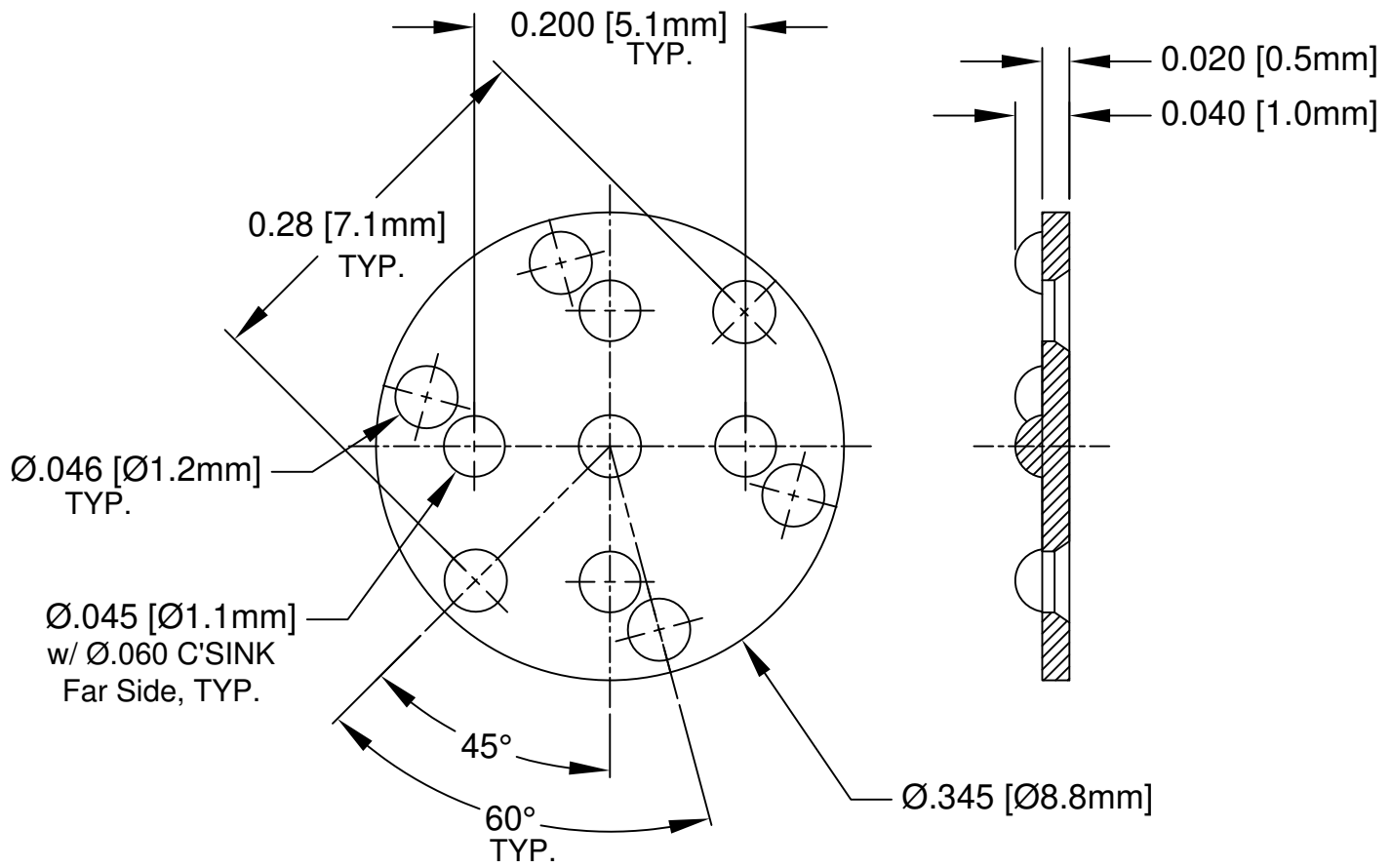
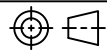

REV.	DESCRIPTION	DATE	APPROVED
A	Engineering Update w/o Changes	02/23/04	M. C.
B	Material update to 03-NL	10/29/07	M. C.
C	Removed Material Code	05/23/16	J. C.



- 2. MATERIAL: NYLON 6/6, 94V-2, NATURAL.
- 1. GENERAL SPECIFICATIONS: BIVAR MOLDED COMPONENT SPECIFICATION BV00-E101.

STANDARD TOLERANCE (UNLESS OTHERWISE SPECIFIED)		 4 THOMAS, IRVINE, CA. 92618 TEL: (949) 951-8808 FAX: (949) 951-3974	
DECIMALS	ANGULAR		
.X ± .1	X° ± 1°	 TITLE: PERM-O-PAD TO-5 MOUNT	
.XX ± .01			
.XXX ± .005		DESIGNED: S. Irving	
		DATE: 09/23/98	
		PART NO: 511-038	
		REVISION: C	
CHECKED: D. Green		DATE: 02/23/04	
		CAGE CODE : 32559	
		SHEET # 1 OF 1	
CAD GENERATED DOCUMENT. DO NOT MEASURE DRAWING.			