

#### 4 Installing the Speaker onto the Mount

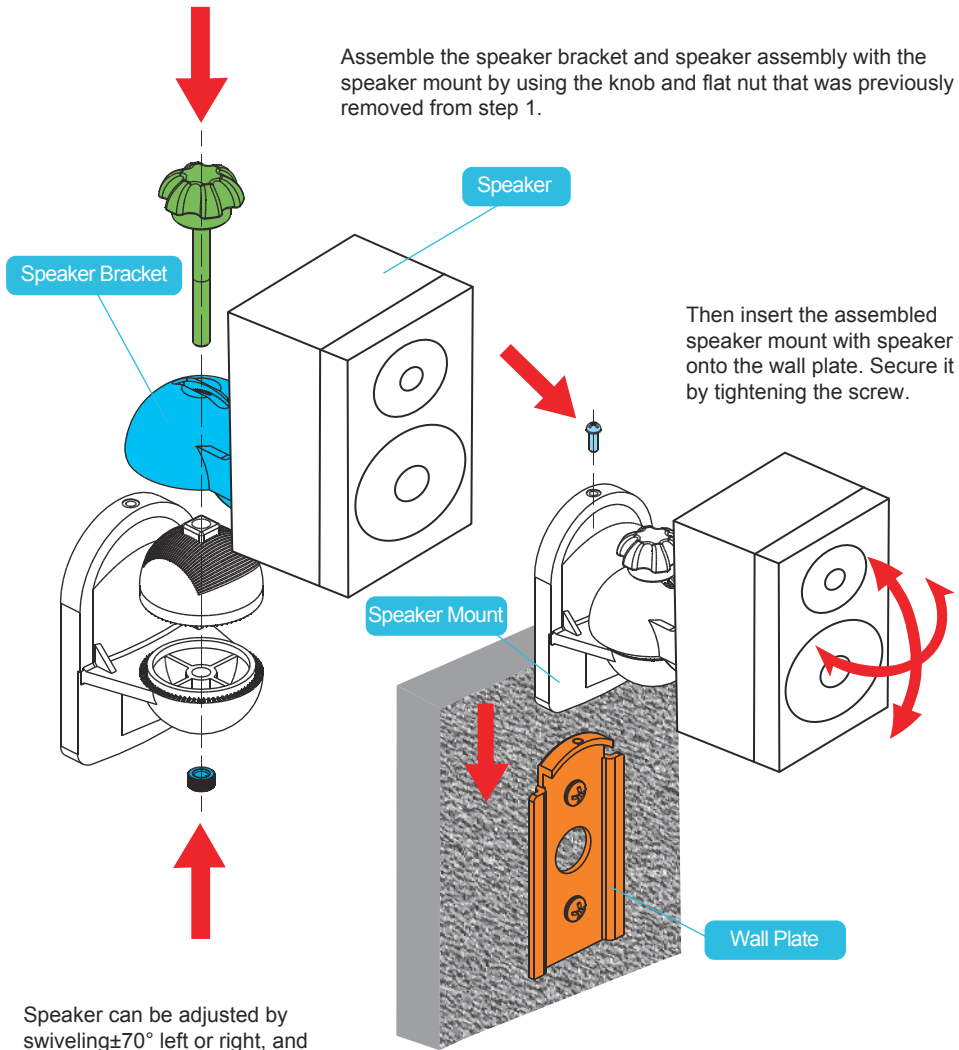

#### Maintenance

Please check that the mount is secure and safe to use at regular intervals. If you have any questions regarding any of the instructions or warnings, please contact your local distributor (OR) contact QualGear technical support via email at [support@qualgear.com](mailto:support@qualgear.com).

# QualGear®

INSTALLATION MANUAL

## QG-SB-002-BLK

### UNIVERSAL SPEAKER WALL MOUNT



[www.qualgear.com](http://www.qualgear.com)

**3.5kg  
(7.7lbs)  
RATED**

#### CAUTION!

Do not exceed the maximum rated weight specified. Otherwise, serious injury or property damage may occur.



■ 1 Year Limited Warranty

■ Version March 2016

**NOTE** Please read the entire installation manual before you start installation and assembly.

## ! WARNING

- Do not begin to install your QualGear product until you have read and understood all the instructions and warnings contained in this installation manual. If you have any questions regarding the instructions, for US customers please contact QualGear customer support via email at support@qualgear.com. For all international customers, please contact your local distributor.
- This product should only be installed by someone of good mechanical aptitude, has experience with basic building construction, and fully understands these instructions.
- This product was designed to be installed and utilized only as specified in this manual. Improper installation of this product may cause damage or serious injury. QualGear is not liable for the improper use or installation of its products.
- Make sure that the supporting surface will safely support the combined load of the equipment and all attached hardware and components.
- Always use an assistant or mechanical lifting equipment to safely lift and position the equipment.
- Tighten screws firmly, but do not over tighten. Over tightening can damage the items, greatly reducing their holding power.
- ALL QUALGEAR products are intended for indoor use only and any outdoor use voids the limited warranty.
- ALL QUALGEAR products are designed and tested for residential use only and any commercial use voids the limited warranty. For warranty information, please visit <http://www.qualgear.com/warranty.php>.
- If mounting to wooden studs, make sure that mounting screws are anchored into the center of the studs. Use of an edge-to-edge stud finder is highly recommended.
- Never exceed the maximum rated weight specified in this manual.
- All bolts and screws must be used at the designated points in the installation instructions to prevent property damage and/or personal injury.
- DO NOT install near air conditioner vents or where there is excessive dust or smoke.
- When drilling holes in the wall, it is very important to take care of electrical cables, water, or gas pipes in the wall.

This product was designed to be installed on the following wall construction only:

### WALL CONSTRUCTION

Wooden Stud  
Wooden Beam  
Solid Concrete  
Other

### HARDWARE REQUIRED

Included  
Included  
Included  
Contact Qualified Professional

**! IMPORTANT!** Please read the entire installation manual and check that all parts are included before you start installation and assembly.

## Part and Hardware Package

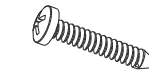

ST4.2x24mm  
Lag Bolt (x4)  
W-A

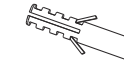

6x29mm Concrete  
Anchor (x4)  
W-B



M5x12 Screw (x4)  
W-C



Marking Template (x1)

## 1 Disassembling the Speaker Wall Mount

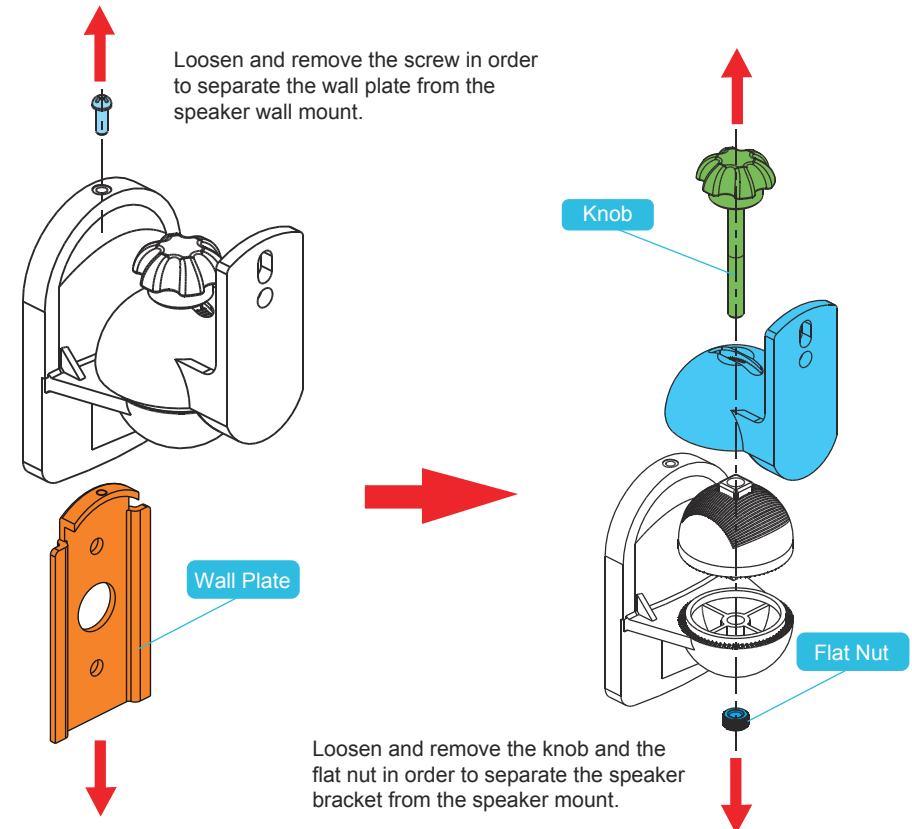

## 2 Installing the Speaker Bracket

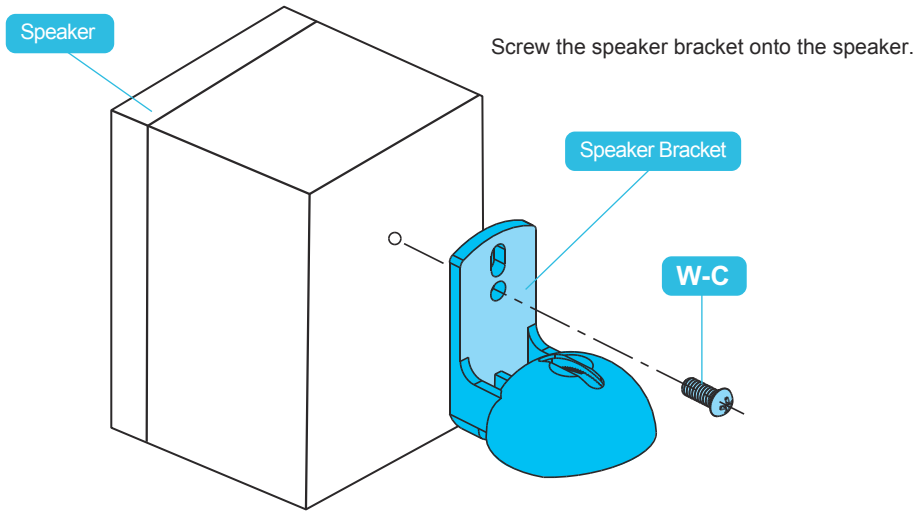

## 3a Mounting to a Wooden Stud Wall

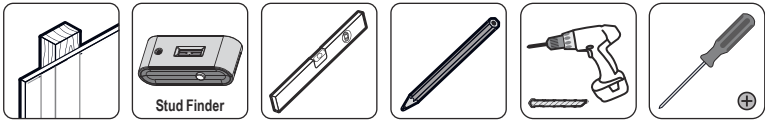

**NOTE** For concrete mounting, see Step 3b.

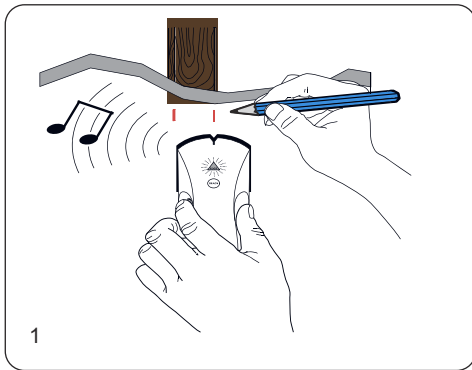

Using an edge-to-edge stud finder, find the edges of the stud.

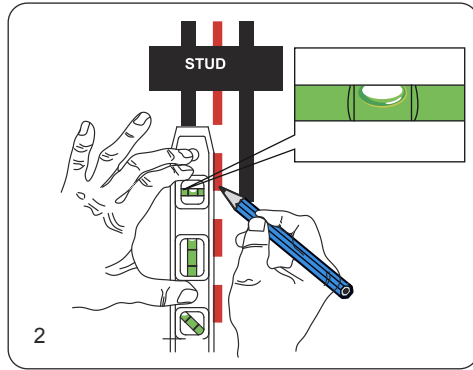

Using a level, mark the centerline of the stud.

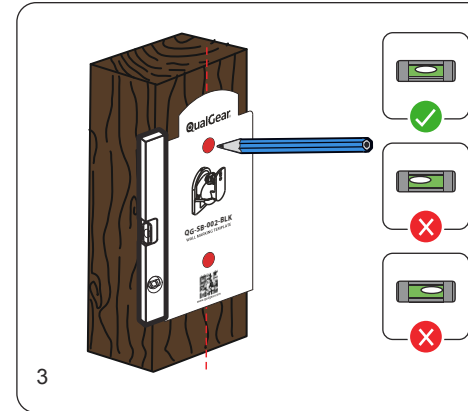

Using the marking template, mark two holes for drilling on the centerline of the stud.

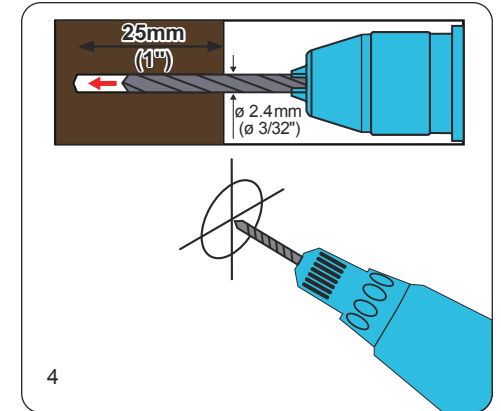

Using a power drill and 3/32" drill bit, drill pilot holes of 3/32" (2.4mm) diameter and at least 1" (25 mm) depth.

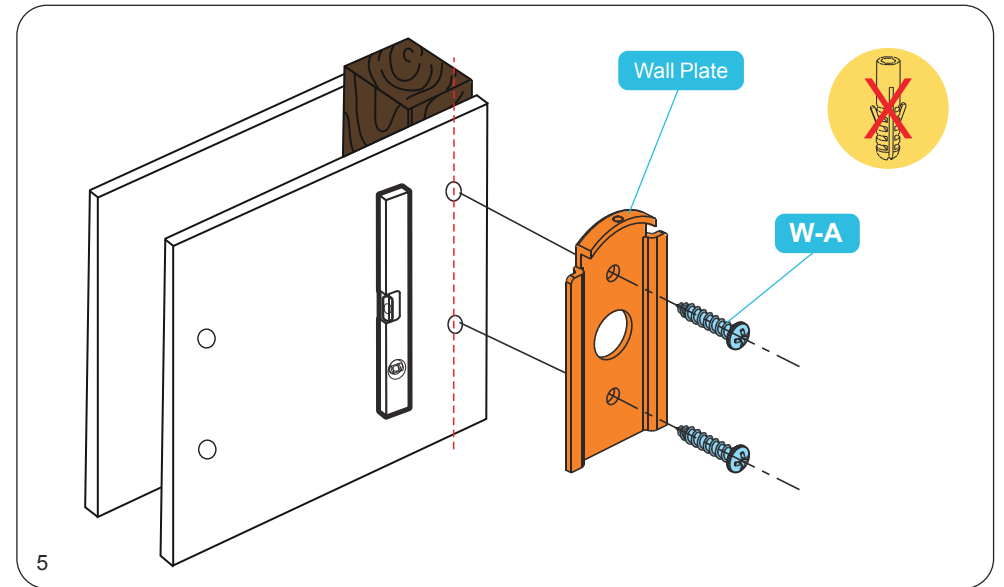

Using a Phillips screwdriver, mount the wall plate and fasten with the provided screws (W-A).

**NOTE** Do NOT use power drill and do NOT over tighten the lag bolts.

**SKIP TO STEP 4** →

### 3b Mounting to a Concrete Wall



Marking Template

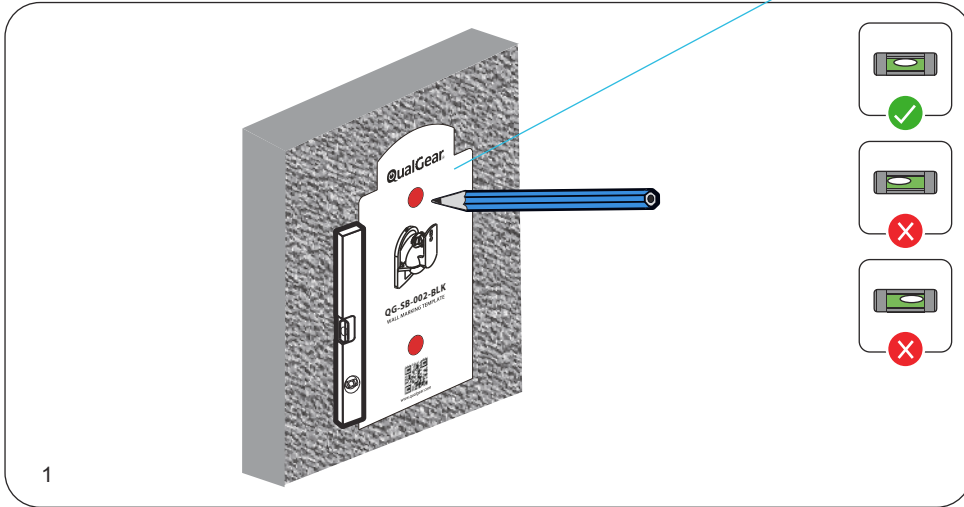

1

Use the marking template, place it against the wall where you want to install the speaker.

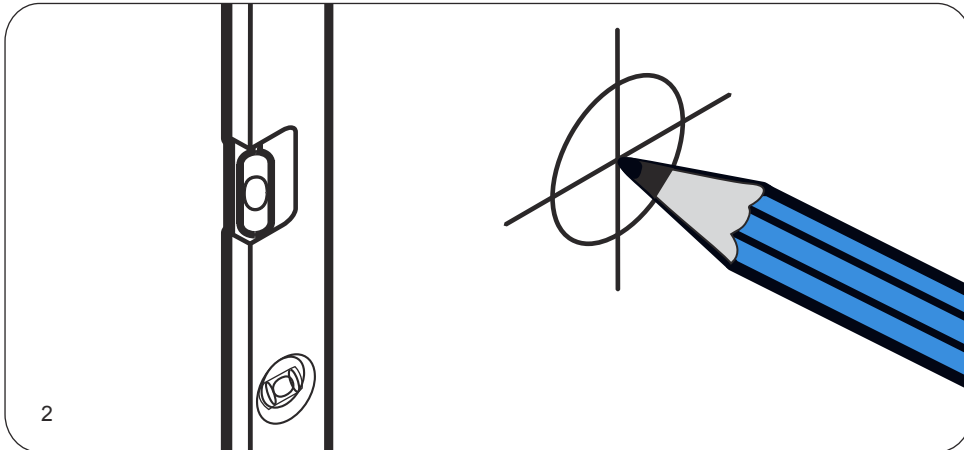

2

Level the marking template and mark two holes for drilling.

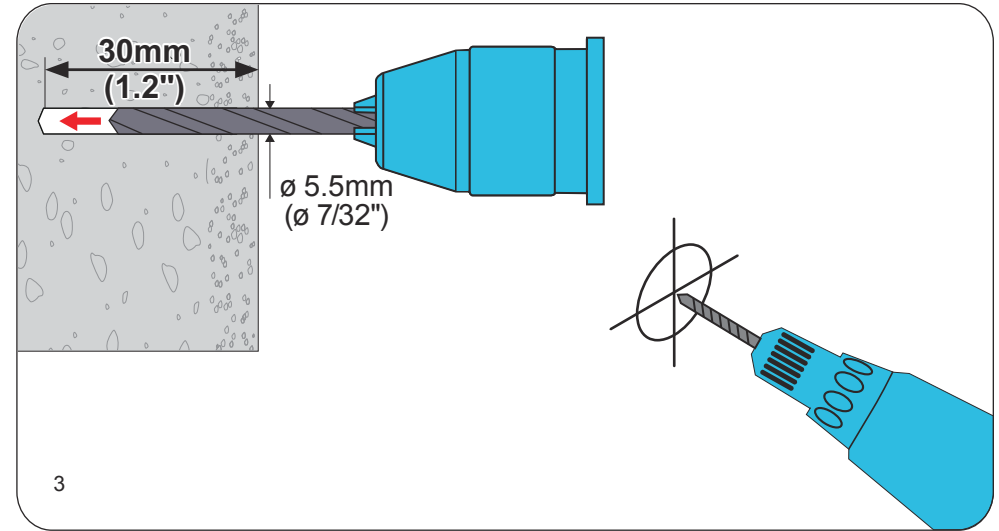

3

Using a power drill and 7/32" masonry drill bit, drill pilot holes of 7/32" (5.5mm) diameter and at least 1.2" (30 mm) depth.

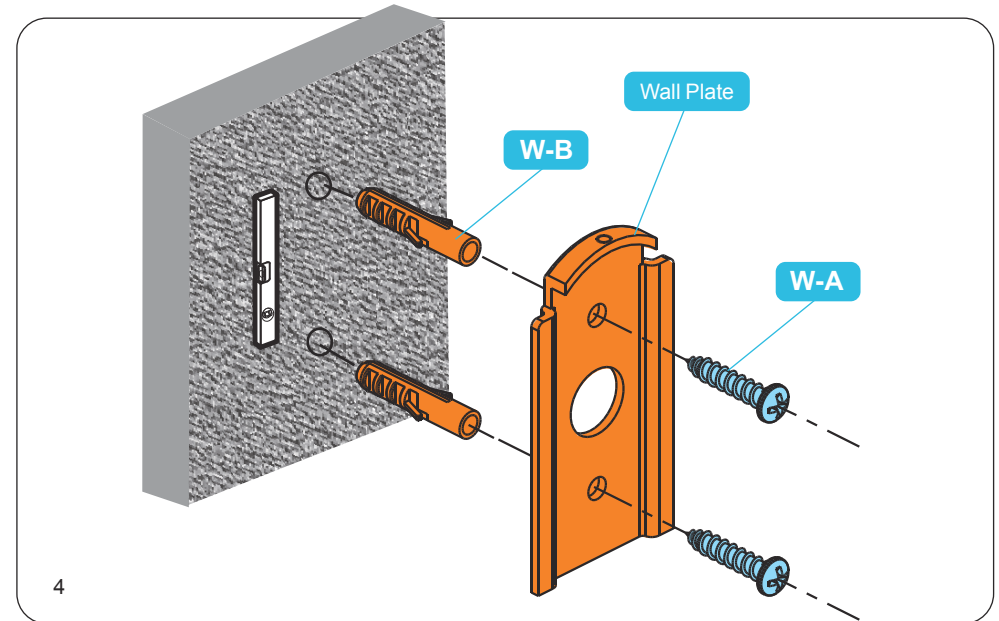

4

Place concrete anchors (W-B) in each hole. Tap each anchor flush with the wall using a hammer. Mount the wall plate and fasten screws (W-A) using a Phillips screwdriver.