

REVISIONS			
REV	DESCRIPTION, ECN, EAR NO.	DATE	APP'D
A	NEW PROPOSAL	JUL19/22	KELVIN

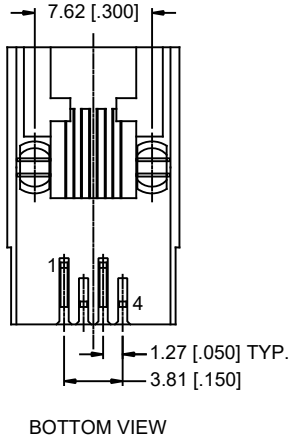
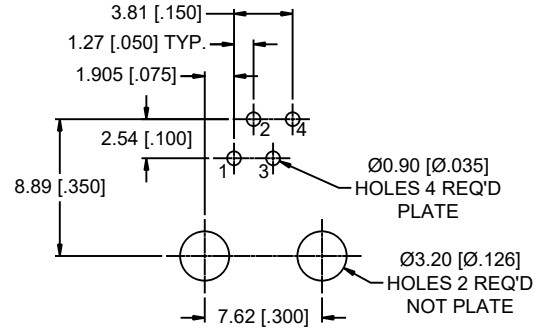
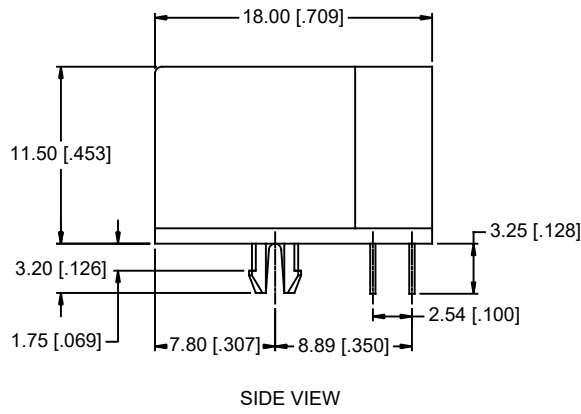
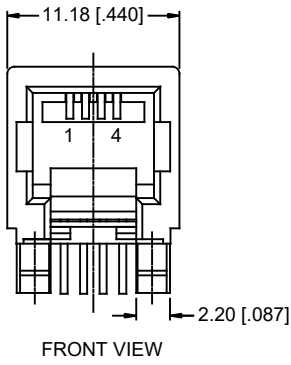

NOTES:

- MATERIALS:**
CONTACTS: PHOSPHOR BRONZE, 0.35MM THICKNESS, PLATING: 6µ "[0.152 MICRONS] MIN. GOLD PLATING ON MATING SURFACES, 50µ "[1.27 MICRONS] MIN. NICKEL OVERALL. GOLD FLASH ON CONTACT TAILS.
HOUSING: ENGINEERING THERMOPLASTIC, FLAMMABILITY RATING UL 94V-0 COLOR - BLACK.
- MECHANICAL:**
MATING FORCE: 5.0 LBS MAXIMUM
- ELECTRICAL:**
CONTACT RESISTANCE: 20 MILLIOHMS MAXIMUM
INSULATION RESISTANCE: 500 MEGOHMS MINIMUM
CURRENT RATING: 1.5 AMPS
VOLTAGE RATING: 125 VOLTS AC
- ENVIRONMENTAL:**
STORAGE TEMPERATURE: -40°C TO +85°C
- RECOMMENDED SOLDERING TEMPERATURE:**
WAVE SOLDERING PEAKED AT 260°C FOR 5 TO 8 SECONDS.

AMPHENOL PART NUMBER: RJE05-144-0110

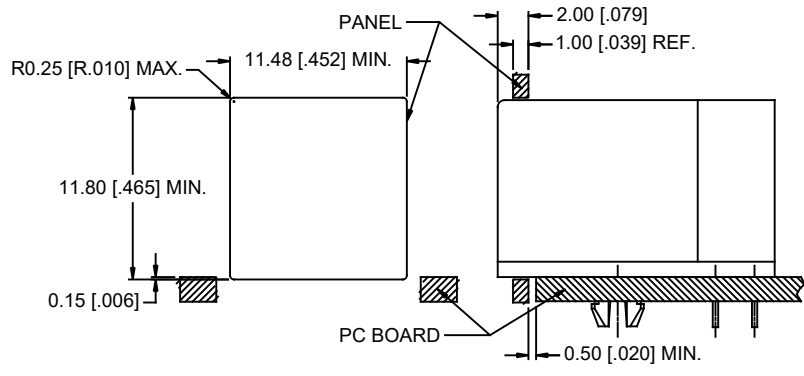

UNLESS SPECIFIED OTHERWISE	DRAWN	RONNIE.C	JUL19/22
PRIMARY UNITS MILLIMETERS	CHECKED	KELVIN.T	JUL19/22
SECONDARY INCHES	M.E. APP'D		
REFERENCE IN PARENTHESES	Q.A. APP'D		
GENERAL TOLERANCES	DWG APP'D		
1 DECIMAL PLACE ±0.25	ENG. REL. NO.		
2 DECIMAL PLACES ±0.13	REF.		
3 DECIMAL PLACES ±0.05			
ANGULAR DEGREES ±2.0°	THIRD ANGLE PROJECTION		

Amphenol Canada Corp. Commercial Products	
SINGLE PORT MODULAR JACK, TAB DOWN, 4 POSITION, 4 CONTACTS, UNSHIELDED -RoHS COMPLIANT	
DWG NO.	P-RJE05-144-0110
CODE ID NO. 03554	DWG SIZE X SCALE N/A SHEET 1 OF 1