

Barometric Pressure Sensor(SKU:TOY0058)



Contents

- [1 Introduction](#)
 - [1.1 Applications](#)
- [2 Specification](#)
- [3 Pin Definition](#)
- [4 Documents](#)
- [5 Characteristic Curve](#)
- [6 Sample](#)
 - [6.1 Sample Code](#)

Introduction

Nowadays, there are more and more navigation devices with GPS function available in the electronic market. But along with high precision micro pressure sensors came, a problem was solved that we cannot know the current altitude, even we can use GPS to determine the location of the equipment. Bosch Sensortec developed a smart, ultra-small size, high precision digital sensor BMP180 to fit high precision measurement and data acquisition for intelligence with high accuracy output of pressure (or height) and temperature measurement data.

Applications

- Temperature Monitoring
- Pressure Monitoring
- Altitude Monitoring

- 3D navigating in the complex indoor spaces(cooperate with accelerometer)

Specification

- Input voltage : 5V
- Operating temperature : -40~+85 °C
- measure accuracy : 0.12hPa/m
- Interface : IIC Digital Output x1

Pin Definition

The definition of Barometric Pressure Sensor sensor pin is

1. +5V
2. GND
3. SCL
4. SDA

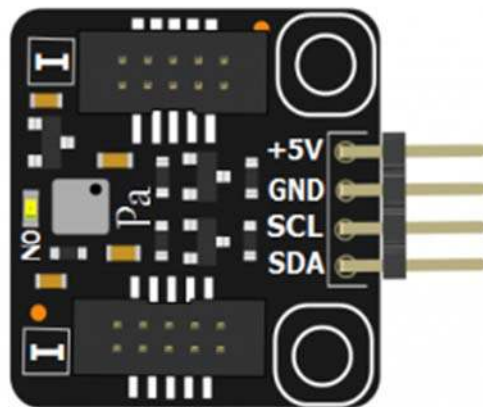

Pin Definition

Characteristic Curve

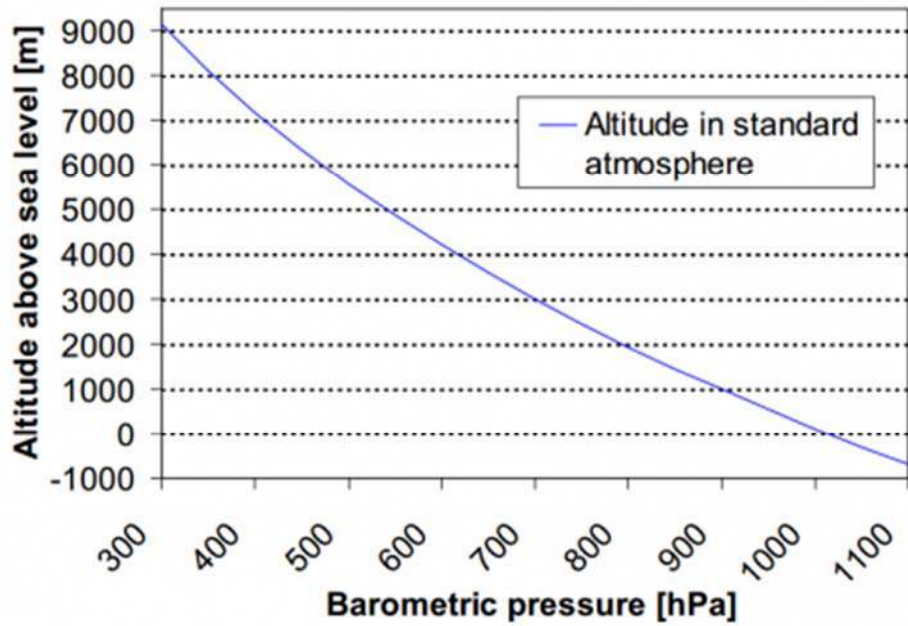

Transfer function: Altitude over sea level – Barometric pressure

Sample

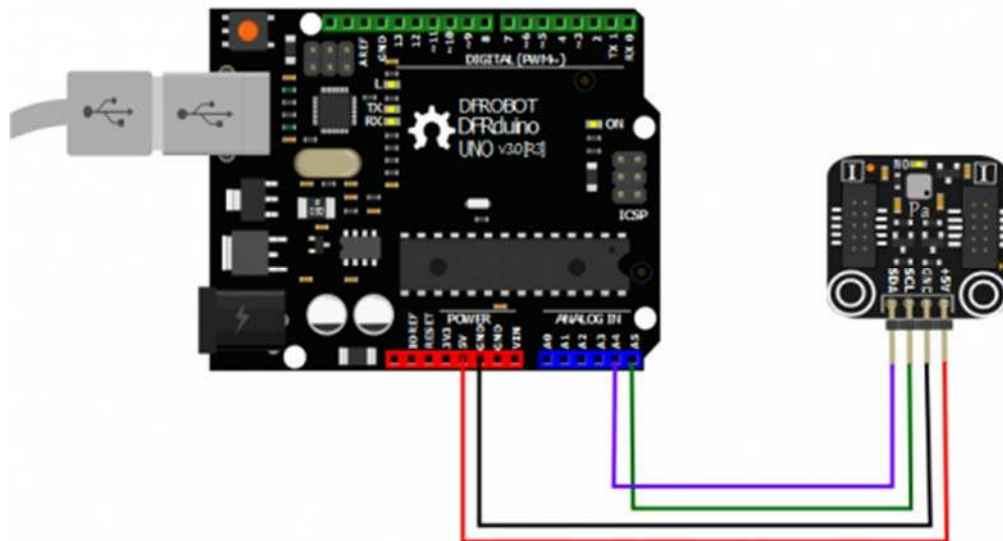

TOY0058 diagram

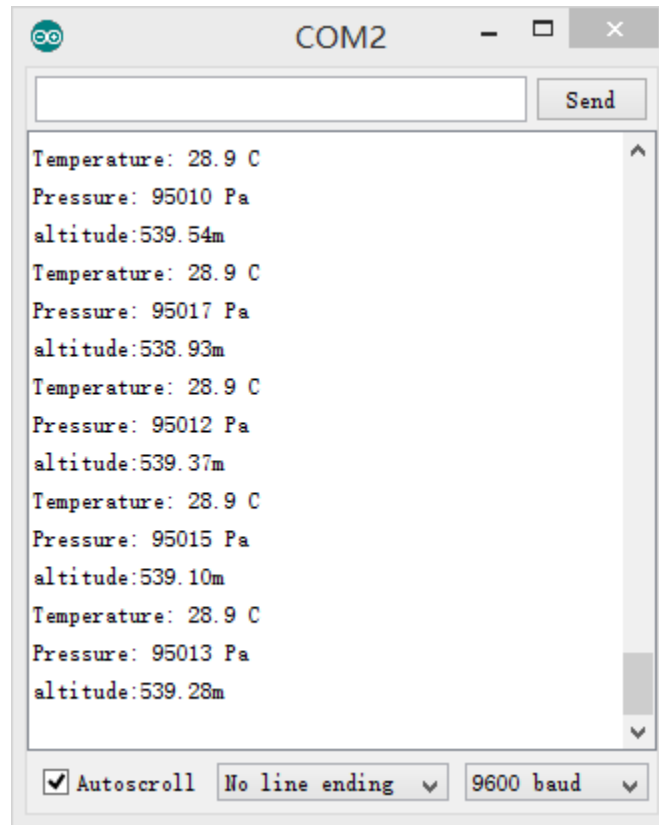

The result in Serial Monitor

Sample Code

```
/*  
*****  
******/  
  
/******DFRobot.com******/  
  
/**write by Tom Riddler      Jun.16.14***/  
  
/**if you got any progream,please contact me terminatorfxy@hotmail.com***/  
  
#include <Wire.h>  
#define BMP180ADD 0xEE>>1 // I2C address of BMP180  
                          //write is (0xEE)      read is (0xEF)  
  
unsigned char OSS;  
  
/******MSB      LSB******/  
int acl;          // 0xAA      0xAB
```

```

int ac2;          // 0xAC    0xAD
int ac3;          // 0xAE    0xAE
unsigned int ac4; // 0xB0    0xB1
unsigned int ac5; // 0xB2    0xB3
unsigned int ac6; // 0xB4    0xB5
int b1;           // 0xB6    0xB7
int b2;           // 0xB8    0xB9
int mb;           // 0xBA    0xBB
int mc;           // 0xBC    0xBD
int md;           // 0xBE    0xBF

float temperature;
double pressure;
double pressure2;
long b5;
double altitude;

void setup()
{
  Serial.begin(9600);
  Wire.begin();

  OSS = 2; // Oversampling Setting          0: single    1: 2 times    2: 4
times    3: 8 times

  BMP180start();
}

void loop()
{
  calculate();
  show();
  delay(1000);
}

```

```

/** calculate centure **/
void calculate()
{
    temperature = bmp180GetTemperature(bmp180ReadUT());
    temperature = temperature*0.1;
    pressure = bmp180GetPressure(bmp180ReadUP());
    pressure2 = pressure/101325;
    pressure2 = pow(pressure2,0.19029496);
    altitude = 44330*(1-pressure2); //altitude = 443
    30*(1-(pressure/101325)^0.19029496);
}

/** print reslut **/
void show()
{
    Serial.print("Temperature: ");
    Serial.print(temperature, 1); //10 hexadecimal
    Serial.println(" C");
    Serial.print("Pressure: ");
    Serial.print(pressure, 0); //10 hexadecimal
    Serial.println(" Pa");
    Serial.print("altitude:");
    Serial.print(altitude);
    Serial.println("m");
}

/**BMP180 satrt program**/
void BMP180start()
{
    //MSB*/
    ac1 = bmp180ReadDate(0xAA); //get full data
    ac2 = bmp180ReadDate(0xAC);
    ac3 = bmp180ReadDate(0xAE);
    ac4 = bmp180ReadDate(0xB0);
    ac5 = bmp180ReadDate(0xB2);
}

```

```

    ac6 = bmp180ReadDate(0xB4);
    b1  = bmp180ReadDate(0xB6);
    b2  = bmp180ReadDate(0xB8);
    mb  = bmp180ReadDate(0xBA);
    mc  = bmp180ReadDate(0xBC);
    md  = bmp180ReadDate(0xBE);
}

/**BMP180 temperature Calculate***/
short bmp180GetTemperature(unsigned int ut)
{
    long x1, x2;
    x1 = ((long)ut - (long)ac6)*(long)ac5 >> 15; //x1=((ut-ac6)*ac5)/(2^15)
    x2 = ((long)mc << 11)/(x1 + md); //x2=(mc*2^11)/(x1+md)
    b5 = x1 + x2; //b5=x1+x2
    return ((b5 + 8)>>4); //t=(b5+8)/(2^4)
}

/**BMP180 pressure Calculate***/

long bmp180GetPressure(unsigned long up)
{
    long x1, x2, x3, b3, b6, p;
    unsigned long b4, b7;

    b6 = b5 - 4000;

    x1 = (b2 * (b6 * b6)>>12)>>11;
    x2 = (ac2 * b6)>>11;
    x3 = x1 + x2;
    b3 = (((((long)ac1)*4 + x3)<<OSS) + 2)>>2;

    x1 = (ac3 * b6)>>13;
    x2 = (b1 * ((b6 * b6)>>12))>>16;

```

```

x3 = ((x1 + x2) + 2)>>2;
b4 = (ac4 * (unsigned long)(x3 + 32768))>>15;

b7 = ((unsigned long)(up - b3) * (50000>>OSS));
if (b7 < 0x80000000)
    p = (b7<<1)/b4;
else
    p = (b7/b4)<<1;

x1 = (p>>8) * (p>>8);
x1 = (x1 * 3038)>>16;
x2 = (-7357 * p)>>16;
p += (x1 + x2 + 3791)>>4;

return p;
}

```

```

/**** Read 1 bytes from the BMP180 ****/

```

```

int bmp180Read(unsigned char address)
{
    unsigned char data;

    Wire.beginTransaction(BMP180ADD);
    Wire.write(address);
    Wire.endTransmission();

    Wire.requestFrom(BMP180ADD, 1);
    while(!Wire.available());

    return Wire.read();
}

```



```

/**** Read 2 bytes from the BMP180 ****/
int bmp180ReadDate(unsigned char address)
{
    unsigned char msb, lsb;
    Wire.beginTransaction(BMP180ADD);
    Wire.write(address);
    Wire.endTransmission();
    Wire.requestFrom(BMP180ADD, 2);
    while(Wire.available()<2);
    msb = Wire.read();
    lsb = Wire.read();
    return (int) msb<<8 | lsb;
}

/**** read uncompensated temperature value ****/
unsigned int bmp180ReadUT()
{
    unsigned int ut;
    Wire.beginTransaction(BMP180ADD);
    Wire.write(0xF4); // Write 0x2E into Register 0xF4
    Wire.write(0x2E); // This requests a temperature reading
    Wire.endTransmission();
    delay(5); // Wait at least 4.5ms
    ut = bmp180ReadDate(0xF6); // read MSB from 0xF6 read LSB from (16 bit)
    return ut;
}

/**** Read uncompensated pressure value from BMP180 ****/
unsigned long bmp180ReadUP()
{
    unsigned char msb, lsb, xlsb;
    unsigned long up = 0;

```

```

Wire.beginTransmission(BMP180ADD);
Wire.write(0xF4); // Write 0x34+(OSS<<6) into register 0xF4
Wire.write(0x34 + (OSS<<6)); // 0x34+oss*64
Wire.endTransmission();
delay(2 + (3<<OSS)); // Wait for conversion, delay time dependent on OSS

Wire.beginTransmission(BMP180ADD);
Wire.write(0xF6); // Read register 0xF6 (MSB), 0xF7 (LSB), and 0xF8 (XLSB)
Wire.endTransmission();

Wire.requestFrom(BMP180ADD, 3);
while(Wire.available() < 3); // Wait for data to become available
msb = Wire.read();
lsb = Wire.read();
xlsb = Wire.read();
up = (((unsigned long) msb << 16) | ((unsigned long) lsb << 8) | (unsigned long) xlsb) >> (8-OSS); //16 to 19 bit
return up;
}

```