

PART NUMBER	ITEM ① INTERFACE INSERT	ITEM ② BASE	ITEM ③ CONTACT	ITEM ④ INSULATOR
127-2701-811	BERYLLIUM COPPER GOLD PL .00005 MIN OVER NICKEL PL .00005 MIN OVER COPPER PL	BRASS GOLD PL .00001 MIN OVER NICKEL PL .00005 MIN OVER COPPER PL	BERYLLIUM COPPER GOLD PL .00005 MIN OVER NICKEL PL .00005 MIN OVER COPPER PL	TEFLON

REV	ECO	DATE
1	INITIAL RELEASE	29APR2020

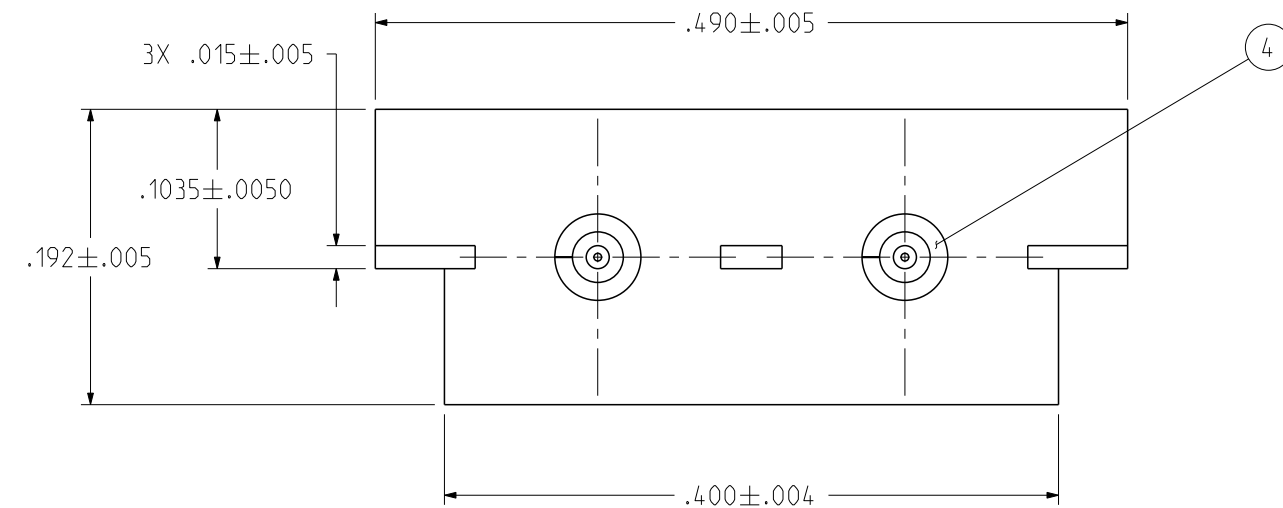
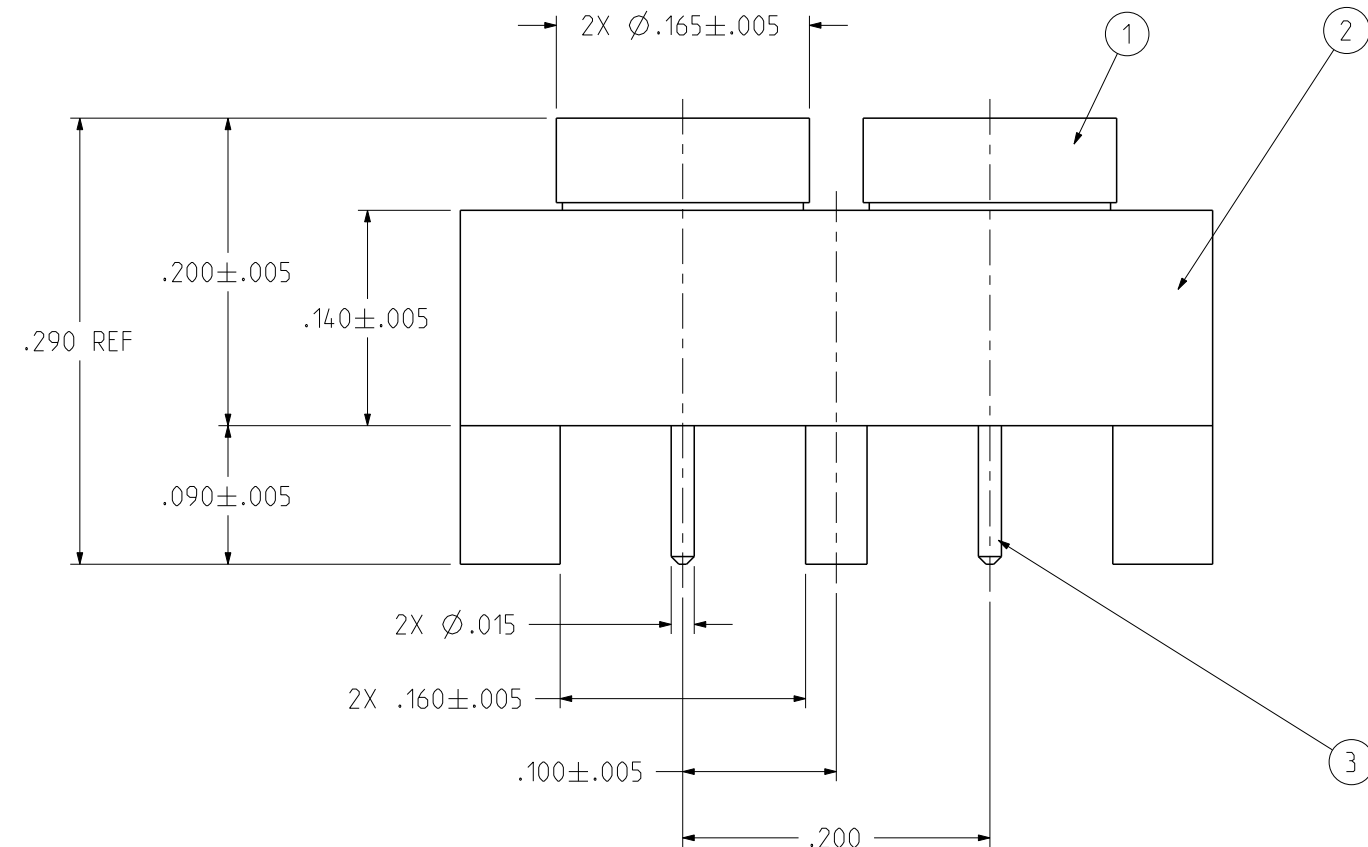
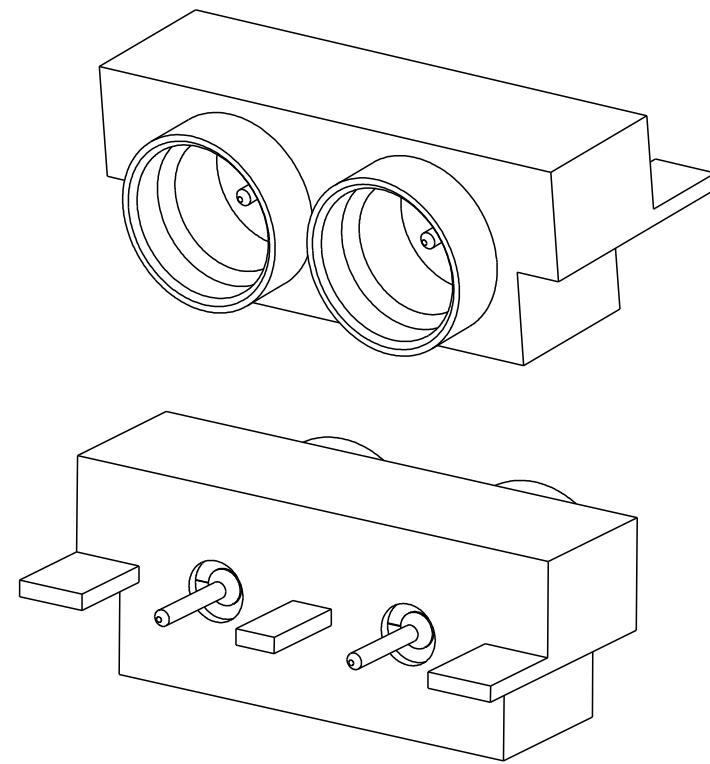

NOTES:

1. ELECTRICAL SPECIFICATIONS:

- 1.1 IMPEDANCE: 50 OHMS NOMINAL
- 1.2 FREQUENCY RANGE: DC-40 GHz
- 1.3 VSWR: 1.15 MAX TO 26.5 GHz, 1.50 MAX TO 40 GHz
- 1.4 WORKING VOLTAGE: 335 VRMS MAX AT SEA LEVEL
- 1.5 DIELECTRIC WITHSTANDING VOLTAGE: 500 VRMS MIN AT SEA LEVEL
- 1.6 INSULATION RESISTANCE: 5000 MEGOHM MIN
- 1.7 CONTACT RESISTANCE:
 - 1.7.1 CENTER CONTACT - INITIAL 6.0 MILLIOHM MAX, AFTER ENVIRONMENTAL NOT APPLICABLE
 - 1.7.2 OUTER CONDUCTOR - INITIAL 2.0 MILLIOHM MAX, AFTER ENVIRONMENTAL NOT APPLICABLE
- 1.8 INSERTION LOSS: $0.06\sqrt{F}$ (GHz) dB MAX
- 1.9 CORONA LEVEL: 190 VOLTS MINIMUM AT 70,000 FEET
- 1.10 RF HIGH POTENTIAL WITHSTANDING VOLTAGE: 325 VRMS MIN AT 4 AND 7 MHz

2. MECHANICAL SPECIFICATIONS:

- 2.1 INTERFACE DESIGN: IN ACCORDANCE WITH MIL-STD-348, SERIES SMP
- 2.2 ENGAGEMENT FORCE: 2 LBS MAX (SMOOTH BORE)
- 2.3 DISENGAGEMENT FORCE: 0.5 LBS MIN (SMOOTH BORE)
- 2.4 DURABILITY: 1000 CYCLES MIN (SMOOTH BORE)

3. ENVIRONMENTAL:

- 3.1 OPERATING TEMPERATURE: -65 °C TO 165 °C
- 3.2 THERMAL SHOCK: MIL-STD-202, METHOD 107, CONDITION B, EXCEPT 165°C HIGH TEMP
- 3.3 MECHANICAL SHOCK: MIL-STD-202, METHOD 213, CONDITION I
- 3.4 CORROSION: MIL-STD-202, METHOD 101, CONDITION B
- 3.5 VIBRATION: MIL-STD-202, METHOD 204, CONDITION D
- 3.6 MOISTURE RESISTANCE: MIL-STD-202, METHOD 106, EXCEPT STEP 7B OMITTED

	Model No: 127-2701-811/820	JOHNSON	
	RoHS <input checked="" type="checkbox"/> (EU)/2015/863 COMPLIANT UNLESS OTHERWISE SPECIFIED UNITS: INCH .XX ± .01 .XXX ± .003 .XXXX ± .0010 ANGLE ± 2°	Cage Code 3RD ANGLE PROJECTION Drawn by: TOMMY REN Date: 04/29/2020	Title: SMP MALE SMOOTH BORE 2-PORT PCB EDGE MOUNT Drawing No. 127-2701-811/820 Size B DO NOT SCALE DRAWING Workmanship Std: NONE Sheet 1 OF 1