

Product Document

Color Sensor, Proximity Detection and IRBeam

www.ams.com/TMD4903



TMD4903 – Color Sensor and Proximity Detection Module with IRBeam Optical Pattern Generator

- Color (RGB) and ambient light sensor with UV/IR blocking for accurate illuminance and color temperature measurement
- IRBeam Optical Pattern Generator supports both mobeam™ Barcode Emulation and Universal Remote Control
- Proximity detection with adaptive dynamic range, automatic crosstalk cancellation and ambient light rejection

We provide innovative analog solutions to the most challenging applications in sensor and sensor interfaces, power management, and wireless.

General Description

The TMD4903 features include Color Sensing (RGB), ALS, Proximity Detection and an IRBeam optical pattern generator capable of mobeam™ barcode emulation and universal remote control. In addition, it includes an integrated LED and advanced LED driver in a low-profile and small footprint 5.0 x 2.0 x 1.0 mm optical module.

The proximity detection function synchronizes IR emission and detection to sense proximity events. The engine's architecture features adaptive dynamic range, ambient light subtraction, automatic crosstalk cancellation, 14-bit data output, 32-dataset FIFO, and interrupt-driven I²C communication. Sensitivity, power consumption, and noise can be optimized with adjustable IR LED timing and power. The proximity engine recognizes detect/release events and produces a configurable interrupt whenever proximity results cross upper or lower threshold settings.

The ambient light and color sensing functions are based on red, green, and blue (RGB) and a clear (C) channel measurements. The RGBC array has UV and IR blocking filters and a parallel ADC to produce simultaneous 16-bit data. This architecture accurately measures ambient light and enables the calculation of illuminance, chromaticity, and color temperature to manage display appearance.

The IRBeam Pattern Generator supports a number of applications including mobeam™ barcode emulation and universal remote control. The engine features a 2048-bit RAM for pattern storage and specialized control logic tailored to repetitively broadcast a barcode pattern using the integrated LED or an external LED. The IRBeam engine features adjustable timing, looping, and IR intensity to maximize successful transmission. It is designed to support all requirements for 1-D barcode transmission over IR to point-of-sale (POS) terminals and universal remote control.

Applications

- Light Color Temperature Measurement
- Ambient Light Sensing for Display Brightness Control
- Cell Phone Touch Screen Disable
- Printed Bar Code Emulation
- Universal Remote Control

Device	Package / Leads	I ² C Interface		Ordering Number
		Address	Bus Voltage	
TMD49033	Module / 8	0X39	1.8V	TMD49033
TMD49037	Module / 8	0X29	1.8V	TMD49037

Block Diagram

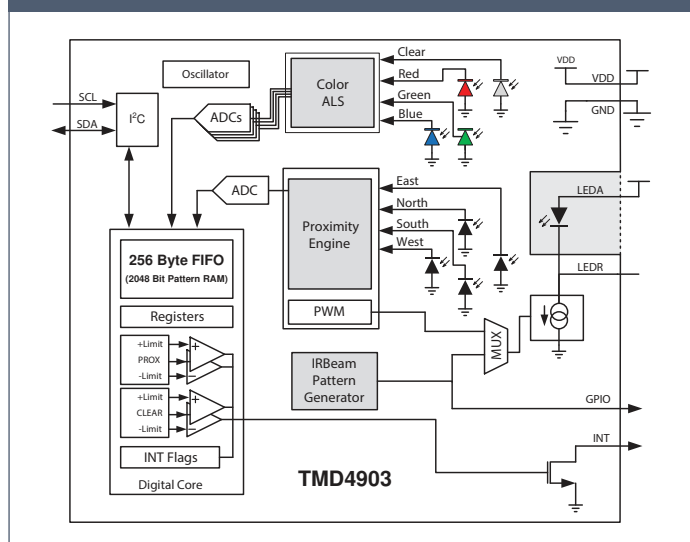

Features

- **Color (RGB) and Ambient Light Sensing**
 - Segmented RGBC Photodiode
 - High sensitivity
 - Ideal for use behind dark glass
 - 6.7M:1 dynamic range
- **IRBeam Optical Pattern Generator**
 - Mobeam™ barcode emulation
 - Universal Remote Control
- **Proximity Detection**
 - Ambient light rejection
 - Advanced crosstalk compensation
- **Power Management**
 - 150 μ A typical current
 - Programmable wait timer
- **Low-Profile Package**
 - 5.0 x 2.0 x 1.0 mm
 - I²C compatible interface with 400 kbits/s data rate

Spectral Responsivity

