



ELECTRONICS, INC.
 44 FARRAND STREET
 BLOOMFIELD, NJ 07003
 (973) 748-5089
<http://www.nteinc.com>

NTE5700 thru NTE5705 Industrial Power Module

Description:

The NTE5700 through NTE5705 series of Integrated Power Circuits consist of power thyristors and power diodes configured in a single package. Applications include power supplies, control circuits and battery chargers.

Features:

- Glass Passivated Junctions for Greater Reliability
- Electrically Isolated Base Plate
- High Dynamic Characteristics

Absolute Maximum Ratings:

Maximum Repetitive Peak Reverse Voltage ($V_S \leq 0$), V_{RRM}	1200V
Maximum Non-Repetitive Peak Reverse Voltage, V_{RSM}	1300V
Maximum Repetitive Peak Off State Voltage Gate Open Circuit, V_{DRM}	1200V

Thermal and Mechanical Characteristics:

Junction Operating Temperature Range, T_J	-40° to +125°C
Storage Temperature Range, T_{stg}	-40° to +150°C
Maximum Internal Thermal Resistance, One Junction-to-Case, R_{thJC}	
DC Operation	2.24K/W
Maximum Thermal Resistance, Base-to-Heatsink, R_{thCS}	
Mounting Surface Smooth and Greased	0.10K/W
Mounting Torque, Base-to-Heatsink $\pm 10\%$ (Note 1), T	5Nm
Approximate Weight, wt	58g (2.0oz)

Note 1. A mounting compound is recommended and the torque should be checked after a period of about 3 hours to allow for the spread of the compound.

Electrical Characteristics:

Parameter	Symbol	Test Conditions		Rating	Unit	
Forward Conduction						
Maximum DC Output Current	I_O	$T_C = +85^\circ\text{C}$, Full Bridge Circuits (NTE5700, NTE5701, NTE5702)		25	A	
Maximum Average On-State and Forward Current	$I_{T(AV)}$ $I_{F(AV)}$	180° Sine Wave Conduction Circuits (All Types)		12.5	A	
Maximum RMS Current	I_{RMS}	180° Sine Wave Conduction Circuit (NTE5702)		28	A	
Maximum Peak, One-Cycle Non-Repetitive On-State or Forward Current	I_{TSM} or I_{FSM}	10ms	100% V_{RRM} Reapplied	Sinusoidal Half Wave, Initial $T_J = T_J \text{ Max}$	300	A
		8.3ms			315	A
		10ms	No Voltage Reapplied		357	A
		8.3ms			375	A
Maximum I^2t for Fusing	I^2t	10ms	100% V_{RRM} Reapplied	Initial $T_J = T_J \text{ Max}$	450	A^2s
		8.3ms			410	A^2s
		10ms	No Voltage Reapplied		637	A^2s
		8.3ms			580	A^2s
Maximum $I^2\sqrt{t}$ for Fusing	$I^2\sqrt{t}$	$t = 0.1$ to 10ms, No Voltage Reapplied, Note 2		6365	$\text{A}^2\sqrt{\text{s}}$	
Maximum Value of Threshold Voltage	$V_{T(TO)}$	$T_J = +125^\circ\text{C}$		0.82	V	
Maximum Value of On-State Slope Resistance	r_T	$T_J = +125^\circ\text{C}$		12	$\text{m}\Omega$	
Maximum Peak On-State or Forward Voltage	V_{TM}	$I_{TM} = \pi \times I_{T(AV)}$	$T_J = +25^\circ\text{C}$, 180° Condition	1.35	V	
	V_{FM}	$I_{FM} = \pi \times I_{F(AV)}$		1.35	V	
Maximum Non-Repetitive Rate of Rise of Turned On Circuit	di/dt	$T_J = +125^\circ\text{C}$, from $0.67V_{DRM}$, $I_{TM} = \pi \times I_{T(AV)}$, $I_g = 500\text{mA}$, $t_r < 0.5\mu\text{s}$, $t_p > 6\mu\text{s}$		200	$\text{A}/\mu\text{s}$	
Maximum Holding Current	I_H	$T_J = +25^\circ\text{C}$, Anode Supply = 6V, Resistive Load, Gate Open Circuit		100	mA	
Maximum Latching Current	I_L	$T_J = +25^\circ\text{C}$, Anode Supply = 6V, Resistive Load		250	mA	
Triggering						
Maximum Peak Gate Power	P_{GM}			8.0	W	
Maximum Average Gate Power	$P_{G(AV)}$			2.0	W	
Maximum Peak Gate Current	I_{GM}			2.0	A	
Maximum Peak Negative Gate Voltage	$-V_{GM}$			10	V	
Maximum Gate Voltage Required to Trigger	V_{GT}	$T_J = -40^\circ\text{C}$		Anode Supply = 6V Resistive Load	3.0	V
		$T_J = +25^\circ\text{C}$			2.0	V
		$T_J = +125^\circ\text{C}$			1.0	V

Electrical Characteristics (Cont'd):

Parameter	Symbol	Test Conditions	Rating	Unit	
Triggering (Cont'd)					
Maximum Gate Current Required to Trigger	I_{GT}	$T_J = -40^\circ\text{C}$	Anode Supply = 6V Resistive Load	90	mA
		$T_J = +25^\circ\text{C}$		60	mA
		$T_J = +125^\circ\text{C}$		35	mA
Maximum Gate Voltage that will not Trigger	V_{GD}	$T_J = +125^\circ\text{C}$, Rated V_{DRM} Applied	0.2	V	
Blocking					
Maximum Critical Rate of Rise of Off-State Voltage	dv/dt	$T_J = +125^\circ\text{C}$, Exponential to $0.67V_{DRM}$, Gate Open Circuit	200	$V/\mu\text{s}$	
Maximum Peak Reverse and Off-State Leakage Current at V_{RRM} , V_{DRM}	I_{RM}	$T_J = T_J \text{ Max}$, Gate Open Circuit	10	mA	
	I_{DM}		2.0	mA	
RMS Isolation Voltage	V_{INS}	50Hz, Circuit to Base, All Terminals Shorted	2500	V	

Note 2. I^2t for time $t_x = I^2 \sqrt{t} \cdot \sqrt{t_x}$.

Pin Connection and Schematic Diagrams:

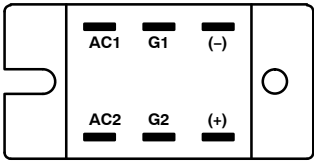
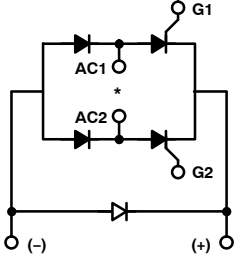
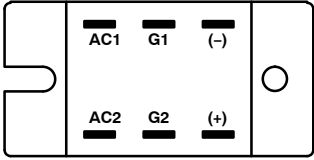
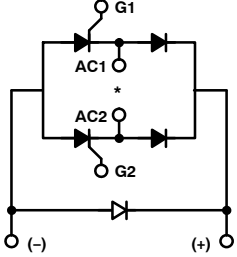
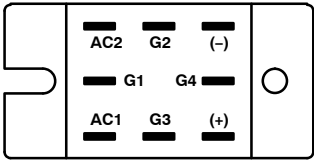
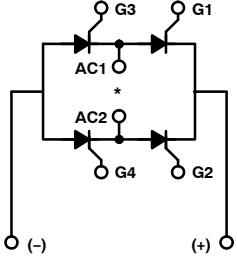
NTE No.	Description	Terminal Positions	Schematic Diagrams
5700	Single Phase, Hybrid Bridge, Common Cathode, Freewheeling Diode		
5701	Single Phase, Hybrid Bridge, Common Anode, Freewheeling Diode		
5702	Single Phase, All SCR Bridge		

* For transient protection, a Metal Oxide Varistor (MOV) may be connected externally across terminals AC1 & AC2.

Pin Connection and Schematic Diagrams (Cont'd):

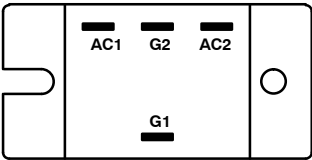
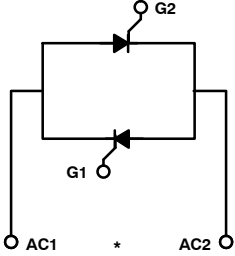
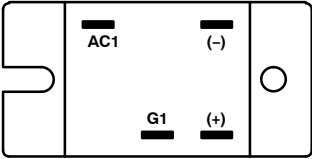
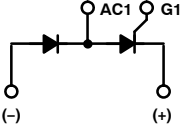
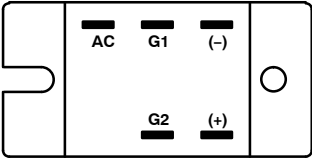
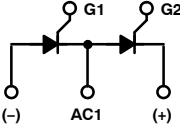
NTE No.	Description	Terminal Positions	Schematic Diagrams
5703	SCR AC Switch		
5704	Hybrid Doubler		
5705	SCR Doubler		

* For transient protection, a Metal Oxide Varistor (MOV) may be connected externally across terminals AC1 & AC2.

