

MATERIALS AND FINISH

BODY: ZINC ALLOY
PLATED SEE TABLE

CENTER CONTACT: BERYLLIUM COPPER
PLATED GOLD

CONTACT: BRASS
PLATED GOLD

INSULATOR: TEFLON

JAM NUT: BRASS
PLATED NICKEL

WASHER: PHOSPHOR BRONZE
PLATED NICKEL

ELECTRICAL CHARACTERISTICS:

FREQUENCY RANGE: DC TO 12 GHZ.
NOMINAL IMPEDANCE: 75Ω
RF RETURN LOSS:
CONNECTOR ONLY (MODEL BASED)

FREQUENCY	MIN RL
0-6 GHz	30 dB
6-12 GHz	20 dB

CONNECTOR WITH PCB LAUNCH
(MEASURED DATA WITH OPTIMIZED PCB
LAUNCH, FOR REFERENCE ONLY)

FREQUENCY	MIN RL
0-6 GHz	22 dB
6-12 GHz	16 dB

RF INSERTION LOSS: 0.5 dB MAX

73171-6898	.079/2.01	TIN	NOT INCLUDING	NOT INCLUDING	TRAY
73171-6897			89519-4701	89610-0104	
73171-6896			89611-0450	89610-0104	
73171-6895	.118/3.00	GOLD	NOT INCLUDING	NOT INCLUDING	TRAY
73171-6894			89519-4701	89610-0104	
73171-6893		TIN	NOT INCLUDING	NOT INCLUDING	
73171-6892			89519-4701	89610-0104	
73171-6891			89611-0450	89610-0104	
73171-6890					
PART NO.	DIM (IN/MM)	BODY	JAM NUT	WASHER	PACKAGING

PS-73598-0660	ELEC/MECH PERFORMANCE
MIL-STD-348B, FIG. 330-1	BNC JACK INTERFACE
SPECIFICATION	DESCRIPTION

B	2018/10/24	ADD .288±.012 & STAKE MARK PER EWR #11409-H
REV	DATE	DESCRIPTION

RELEASE STATUS P1 RELEASE DATE 2018/11/06 03:56:46

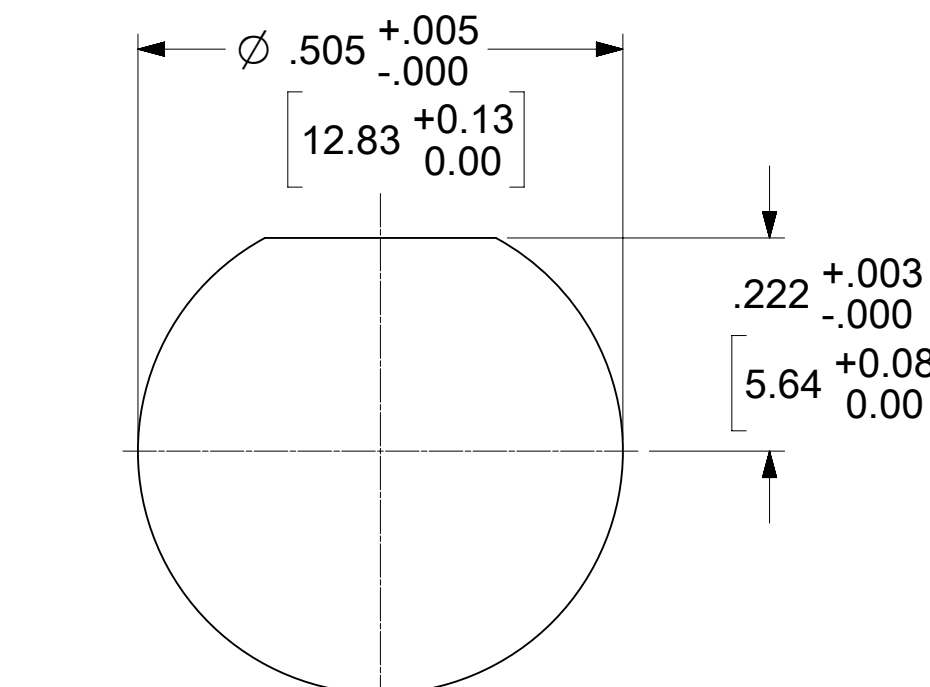
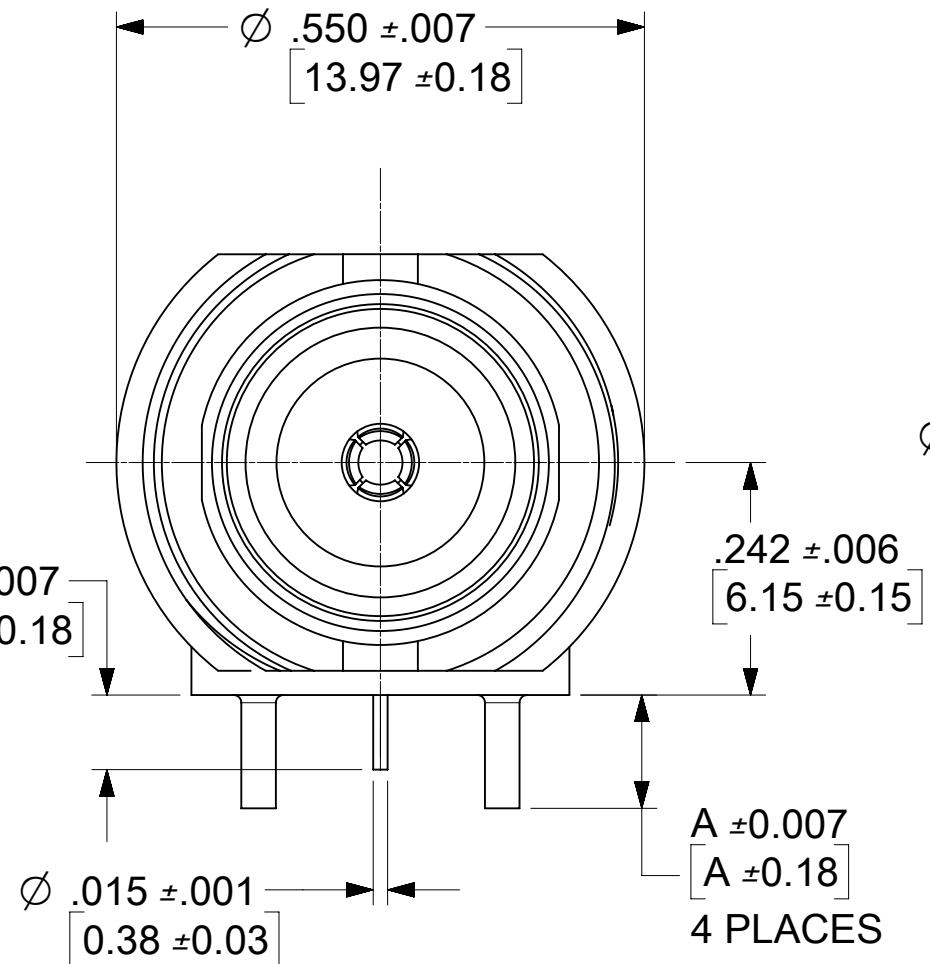

RECOMMENDED PANEL CUTOUT
MAX PANEL THICKNESS: .060/1.52 MAX

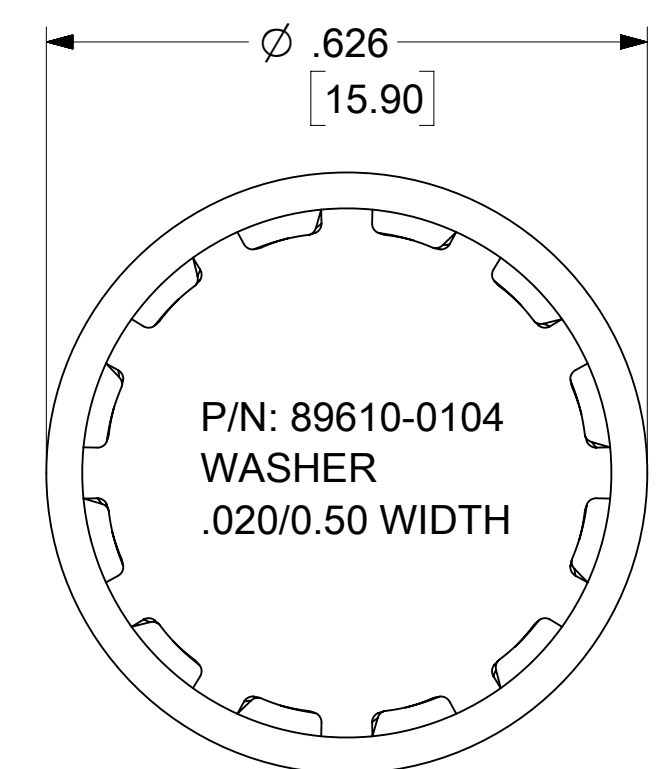
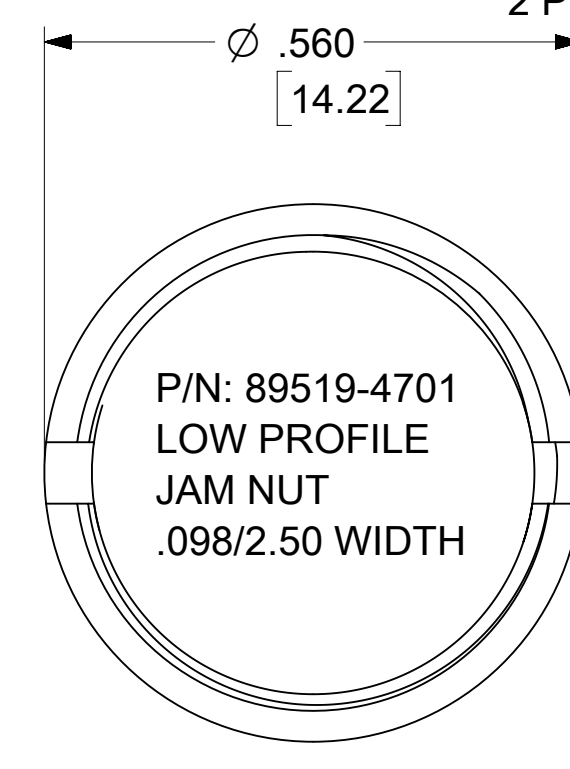
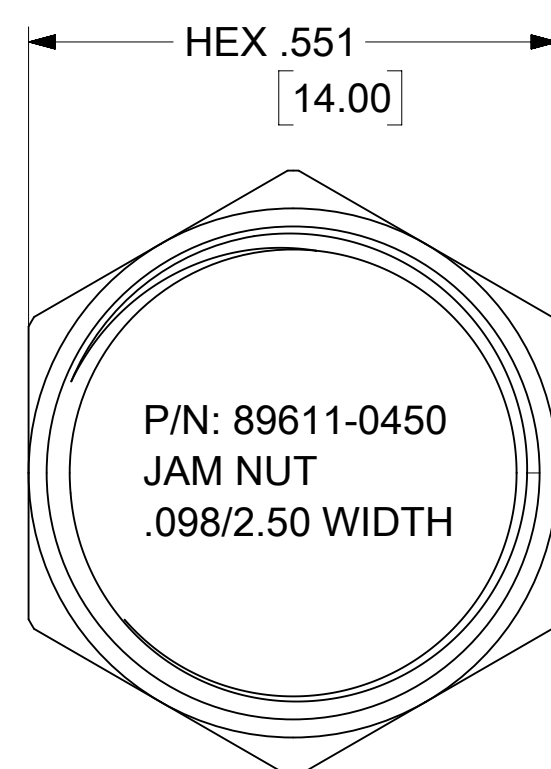
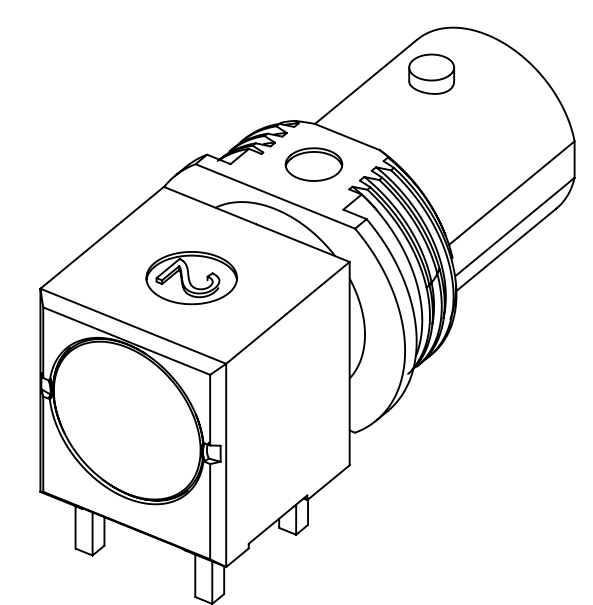
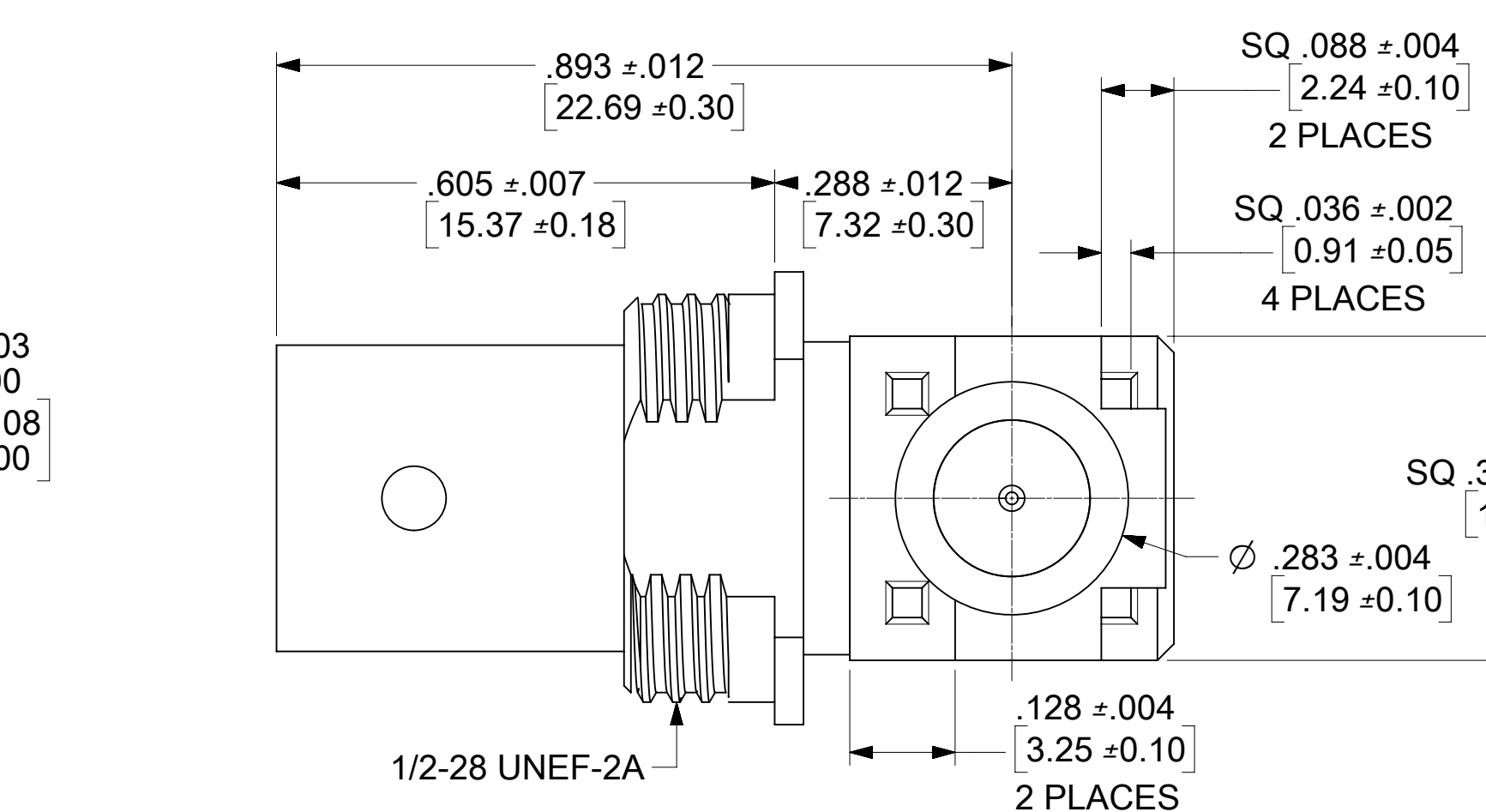
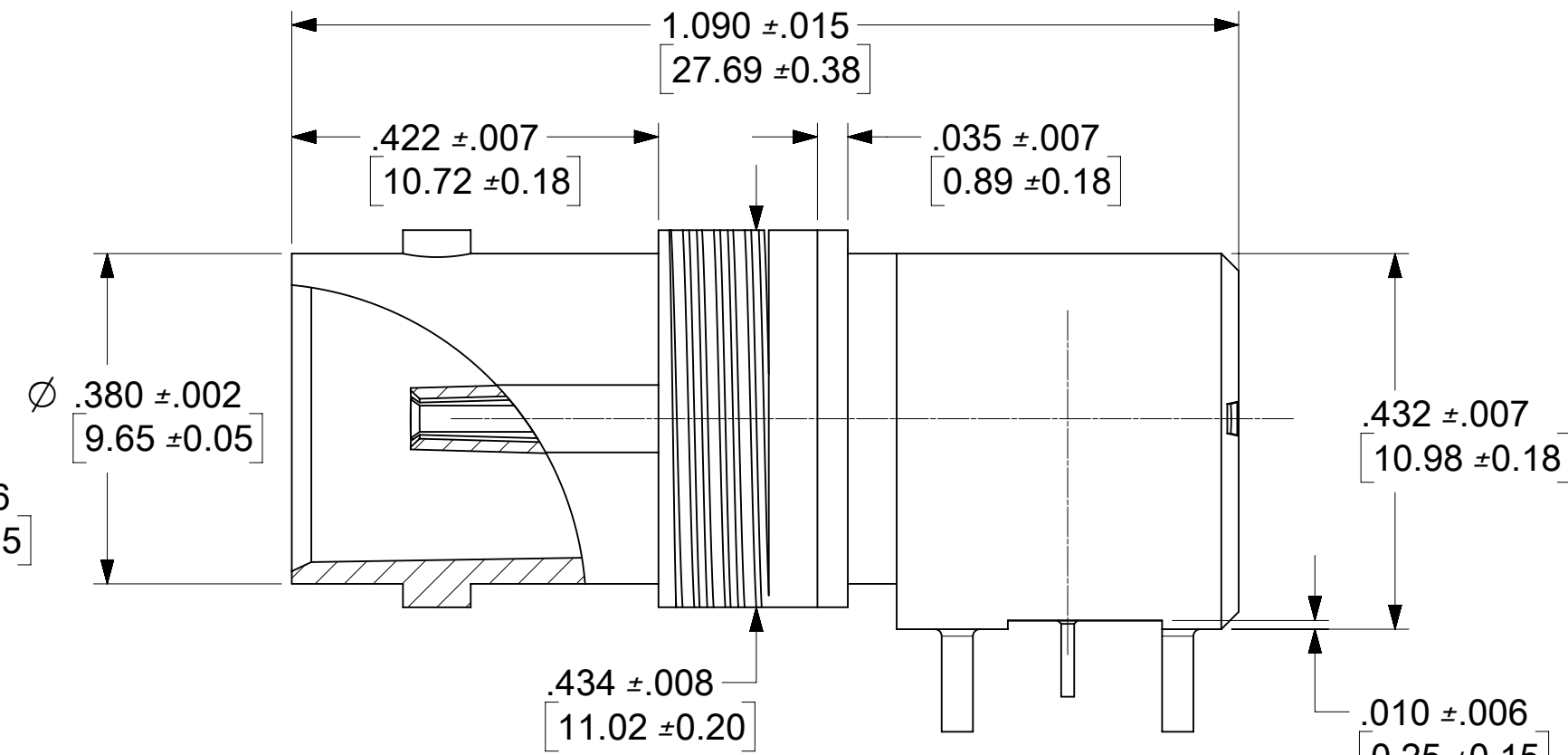

THIS DRAWING CONTAINS INFORMATION THAT IS PROPRIETARY TO MOLEX ELECTRONIC TECHNOLOGIES, LLC AND SHOULD NOT BE USED WITHOUT WRITTEN PERMISSION

EC NO: 606547 DRWN: RYEH CHKD: YCHENG REV: APPR: YCHENG	GENERAL TOLERANCES (UNLESS SPECIFIED) ANGULAR TOL ± °	DIMENSION UNITS: HYBRID SCALE: NTS		
	4 PLACES ± 3 PLACES ± 2 PLACES ± 1 PLACE ± 0 PLACES ±	DRWN BY: RYEH DATE: 2017/10/03		BNC JACK R/A PCB TH DC-12 GHZ DIE CAST VERSION EWR-11409
	DRAFT WHERE APPLICABLE MUST REMAIN WITHIN DIMENSIONS	APPR BY: YCHENG DATE: 2018/01/16		
	DIMENSION UNITS: C THIRD ANGLE PROJECTION	SERIES: 73171 MATERIAL NUMBER: SEE TABLE CUSTOMER:		

DOCUMENT NUMBER: 731716890 DOC TYPE: PSD DOC PART: 000 SHEET NUMBER: 1 OF 3

RECOMMENDED PCB LAYOUT
(THICKNESS 1.60/.063)

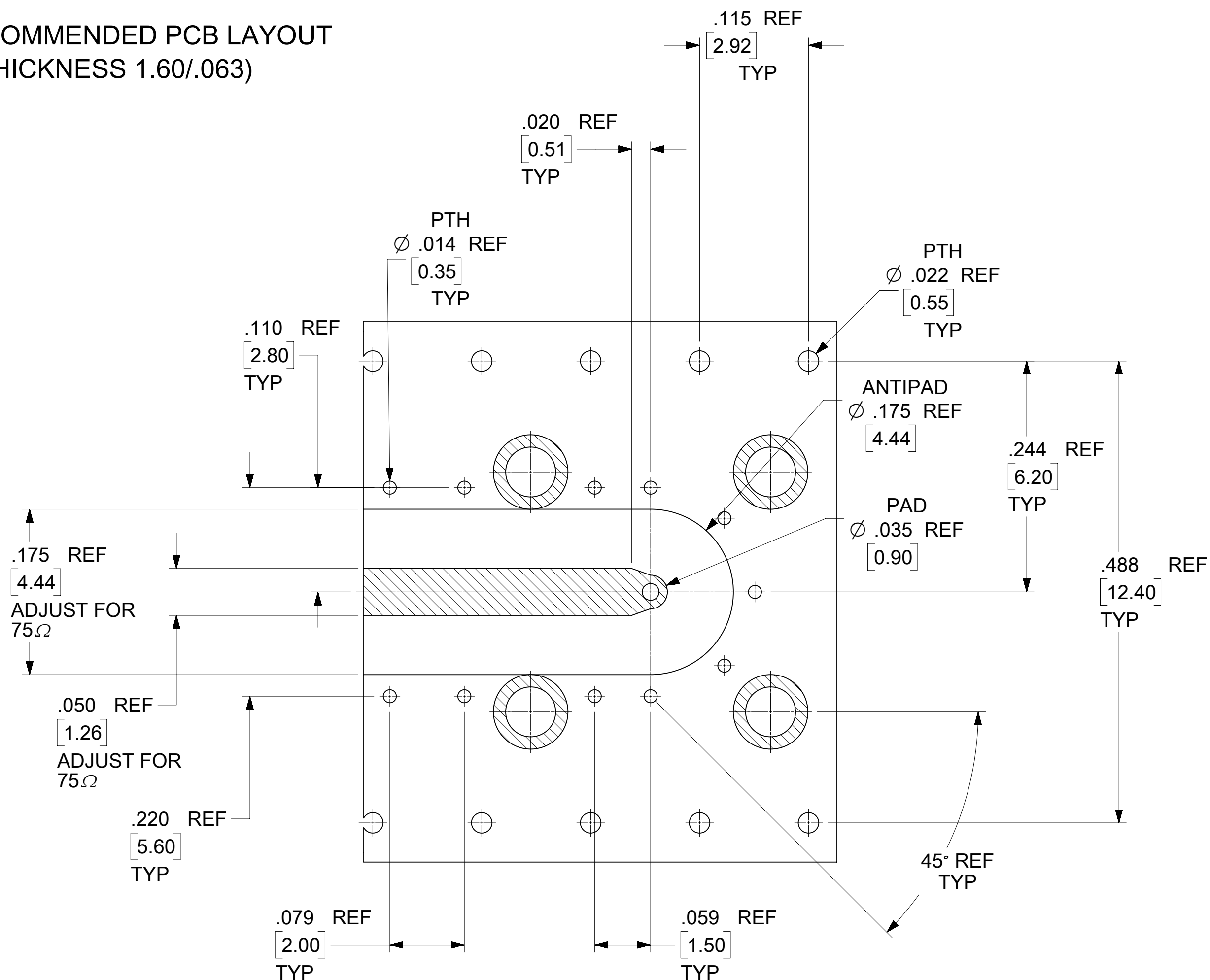
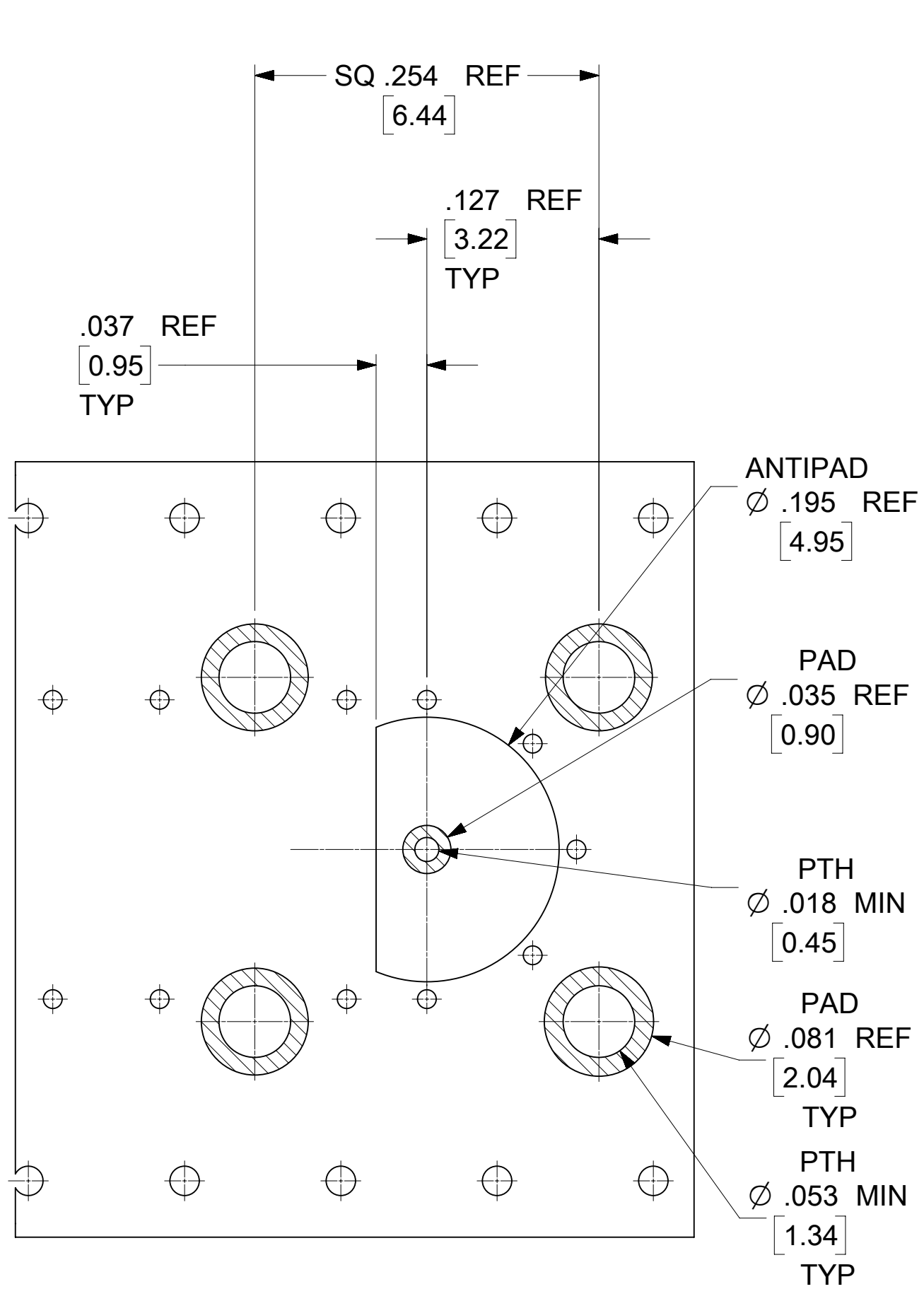

THIS DRAWING CONTAINS INFORMATION THAT IS PROPRIETARY TO MOLEX ELECTRONIC TECHNOLOGIES, LLC AND SHOULD NOT BE USED WITHOUT WRITTEN PERMISSION

EC NO: 606547 DRWN: RYEH CHKD: YCHENG REV / APPR: YCHENG	2018/10/24	2018/11/06	2018/11/06	GENERAL TOLERANCES (UNLESS SPECIFIED)	DIMENSION UNITS	SCALE	molex	BNC JACK R/A PCB TH DC-12 GHZ DIE CAST VERSION EWR-11409
	4 PLACES	±	3 PLACES	±	HYBRID	NTS		
	2 PLACES	±	1 PLACE	±	ANGULAR TOL ±	°	CHKD BY: YCHENG DATE: 2018/01/16	PRODUCT CUSTOMER DRAWING
	0 PLACES	±	DRAFT WHERE APPLICABLE MUST REMAIN WITHIN DIMENSIONS		THIRD ANGLE PROJECTION		APPR BY: YCHENG DATE: 2018/01/16	SERIES: 73171 MATERIAL NUMBER: SEE TABLE CUSTOMER: SEE TABLE
RELEASE STATUS: P1	RELEASE DATE: 2018/11/06	03:56:46					DOCUMENT NUMBER: 731716890	DOC TYPE: PSD DOC PART: 000 SHEET NUMBER: 2 OF 3

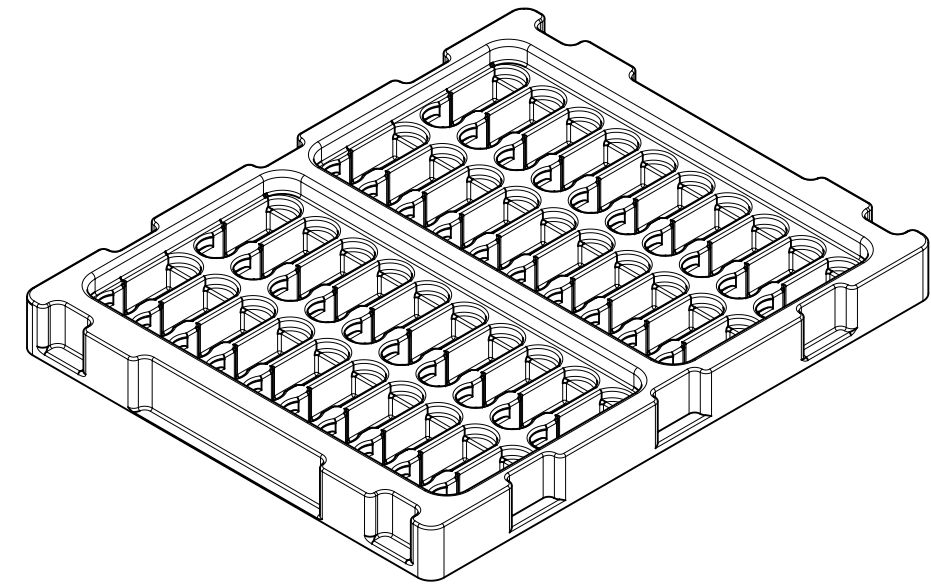
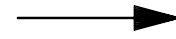
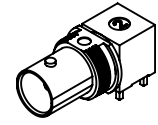

40 SETS PER TRAY
P/N: 89707-0169

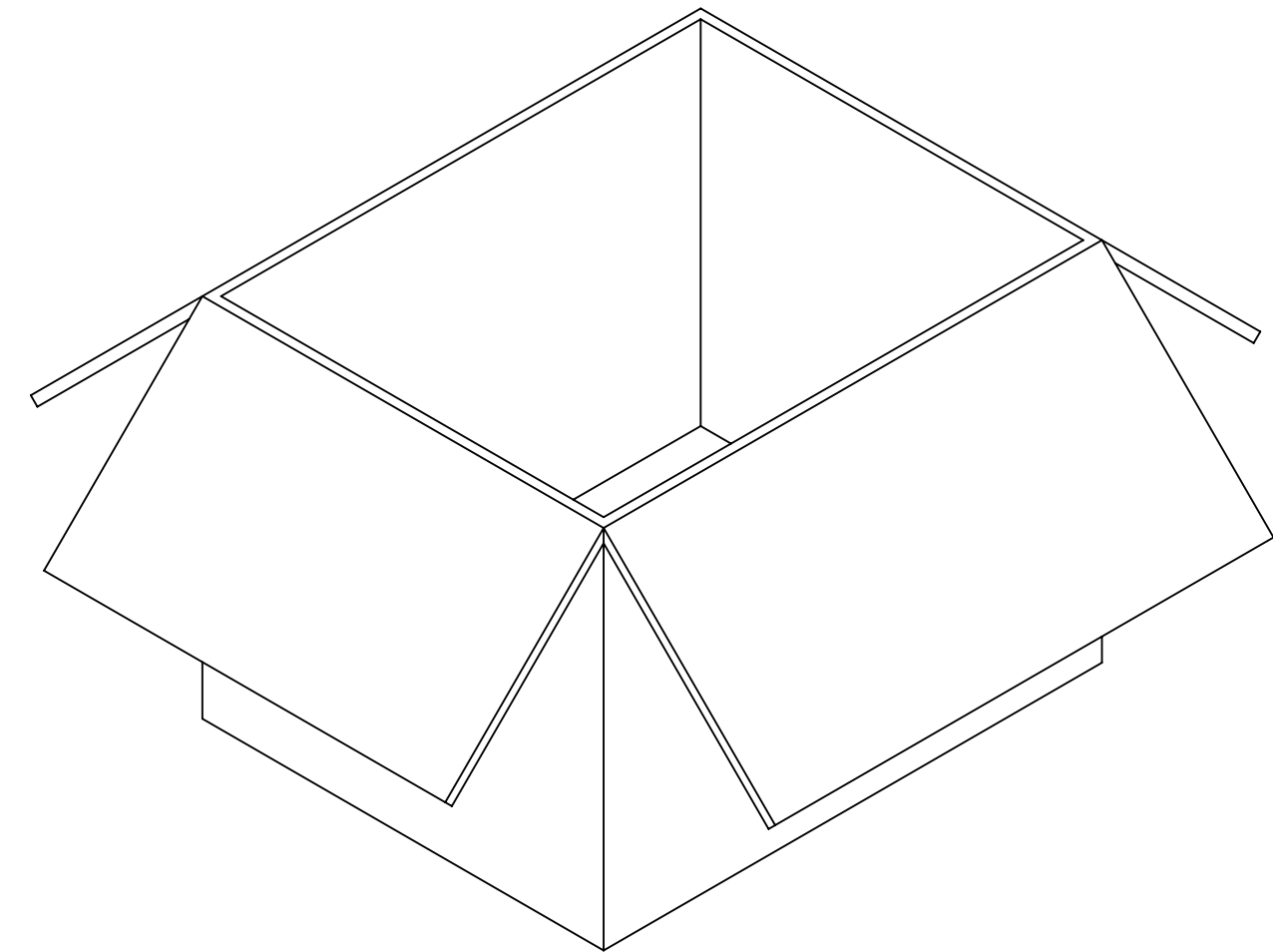
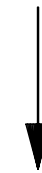

480 SETS PER OUTER
CARTON BOX
P/N: 89499-9027

73171-6898	.079/2.01	TIN	NOT INCLUDING	NOT INCLUDING	TRAY
73171-6897			89519-4701	89610-0104	
73171-6896	.118/3.00	GOLD	NOT INCLUDING	NOT INCLUDING	
73171-6895			89519-4701	89610-0104	
73171-6894			89611-0450		
73171-6893		TIN	NOT INCLUDING	NOT INCLUDING	
73171-6892			89519-4701	89610-0104	
73171-6891			89611-0450		
73171-6890					
PART NO.	DIM (IN/MM)	BODY	JAM NUT	WASHER	PACKAGING

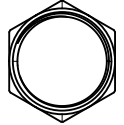

P/N: 89611-0450

480 SETS PER BAG
P/N: 89707-0001

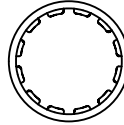

P/N: 89610-0104

480 SETS PER BAG
P/N: 89707-0001

FOR 73171-6890
OR 73171-6893
OR 73171-6896

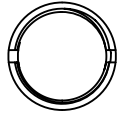

P/N: 89519-4701

480 SETS PER BAG
P/N: 89707-0001

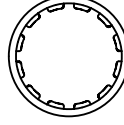

P/N: 89610-0104

480 SETS PER BAG
P/N: 89707-0001

FOR 73171-6891
OR 73171-6894
OR 73171-6897

THIS DRAWING CONTAINS INFORMATION THAT IS PROPRIETARY TO MOLEX ELECTRONIC TECHNOLOGIES, LLC AND SHOULD NOT BE USED WITHOUT WRITTEN PERMISSION											
EC NO: 606547 DRWN: RYEH CHKD: YCHENG REV: APPR: YCHENG	2018/10/24	2018/11/06	2018/11/06	GENERAL TOLERANCES (UNLESS SPECIFIED)		DIMENSION UNITS	SCALE	molex BNC JACK R/A PCB TH DC-12 GHZ DIE CAST VERSION EWR-11409			
	HYBRID		NTS		DRWN BY	DATE					
	ANGULAR TOL ±		°		RYEH	2017/10/03	CHKD BY		DATE		
	4 PLACES	±					APPR BY		DATE		
3 PLACES	±					YCHENG		2018/01/16			
2 PLACES	±					DRAWING SIZE		THIRD ANGLE PROJECTION			
1 PLACE	±					C		73171			
0 PLACES	±					DRAFT WHERE APPLICABLE MUST REMAIN WITHIN DIMENSIONS		731716890			
SERIES		MATERIAL NUMBER		CUSTOMER		DOCUMENT NUMBER		DOC TYPE		DOC PART SHEET NUMBER	
		SEE TABLE				731716890		PSD		000 3 OF 3	