

FEMALE MICRO-CHANGE M12 STRAIGHT TO MALE MICRO-CHANGE M12 STRAIGHT

ELECTRICAL SPECIFICATIONS :

VOLTAGE RATING : 3-4P = 250V

5P = 60V

8P = 30V

CURRENT RATING : 3-5P = 4 AMPS

8P = 2 AMPS

INSULATION RESISTANCE : $10^8 \Omega$ MN

MATING CYCLES : MAX. 100

ENVIRONMENTAL PROTECTION : IP67

OPERATING TEMPERATURE : -25°C TO +85°C

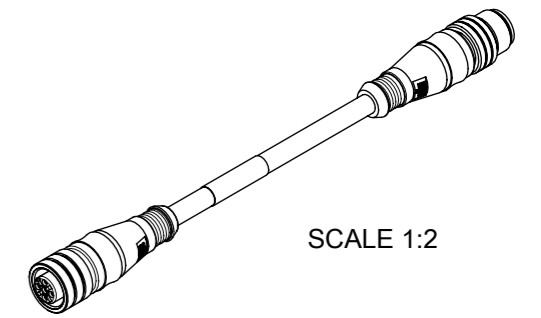

SCALE 1:2

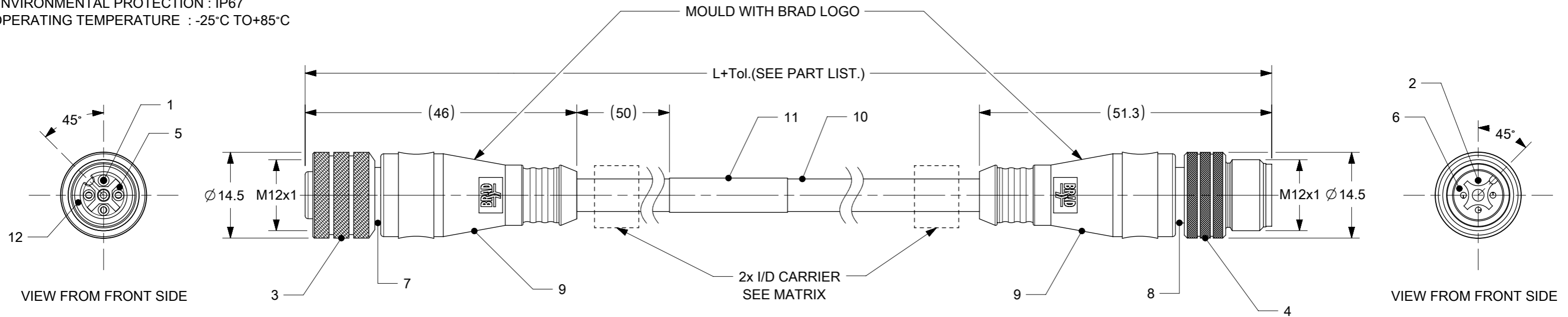

CONTACTS POSITION FRONT VIEW:

	3 CONTACTS	4 CONTACTS	5 CONTACTS	8 CONTACTS				
FEMALE								
MALE								
CONNECTIONS	PIN	WIRE	PIN	WIRE	PIN	WIRE	PIN	WIRE
	1	BROWN	1	BROWN	1	BROWN	1	WHITE
	2	-	2	WHITE	2	WHITE	2	BROWN
	3	BLUE	3	BLUE	3	BLUE	3	GREEN
	4	BLACK	4	BLACK	4	BLACK	4	YELLOW
					5	GREY	5	GREY
							6	PINK
							7	BLUE
						8	RED	

CODING REQUIRED TO IEC 61076-2-101

BOM

ITEM	QTY.	DESCRIPTION	MATERIAL	FINISH/COLOR
1	3/ 4 / 5 / 8	CONTACT FEMALE	BRASS	SELECTIVE GOLD OVER NICKEL
2	3/ 4 / 5 / 8	CONTACT MALE	BRASS	SELECTIVE GOLD OVER NICKEL
3	1	COUPLING NUT FEMALE	BRASS	Ni-PLATED
4	1	COUPLING NUT MALE	BRASS	Ni-PLATED
5	1	M12 INSERT FEMALE	PUR	BLACK
6	1	M12 INSERT MALE	PUR	BLACK
7	1	SLEEVE SHLD FEMALE	BRASS	Ni-PLATED
8	1	SLEEVE SHLD MALE	BRASS	Ni-PLATED
9	-	OVERMOULD	TPU	SEE MATRIX
10	-	CABLE	SEE MATRIX	SEE MATRIX
11	1	LABEL YELLOW	VINYL	-
12	1	O-RING	FPM	RED

THIS DRAWING CONTAINS INFORMATION THAT IS PROPRIETARY TO MOLEX ELECTRONIC TECHNOLOGIES, LLC AND SHOULD NOT BE USED WITHOUT WRITTEN PERMISSION

DIMENSION UNITS	SCALE	CURRENT REV DESC: REMOVED OBSOLETE PART NUMBER AS PER PCN#512871.			
mm	2:1				
GENERAL TOLERANCES (UNLESS SPECIFIED)			MICRO-CHANGE ASSEMBLY MALE/FEMALE, SHIELDED 3-8 POLE PRODUCT CUSTOMER DRAWING		
ANGULAR TOL	± 1.0°				
4 PLACES	±	EC NO: 732259			
3 PLACES	±	DRWN: SANTHN 2022/12/15			
2 PLACES	± 0.05	CHK'D: GGA 2022/12/21			
1 PLACE	± 0.3	APPR: GGA 2022/12/21			
0 PLACES	± 0.5	INITIAL REVISION:	DOCUMENT NUMBER		
DRAFT WHERE APPLICABLE MUST REMAIN WITHIN DIMENSIONS			SD-120069-041		
THIRD ANGLE PROJECTION			DOC TYPE DOC PART REVISION		
DRAWING			PSD 001 A5		
SERIES			MATERIAL NUMBER		
A3-SIZE			120069		
CUSTOMER			GENERAL MARKET		
SHEET NUMBER			1 OF 3		

ENGINEERING NO. - NUMERICAL CODE

8 8 X S 3 0 X X X M X X X X X

OPTIONS

8 = M12 MICRO CHANGE

8 = M12 MICRO CHANGE

S30= Double-Ended Cordset Shielded Female Straight to Shielded Male Straight

Units:
M=Meter
F=Feet

Length
Examples:
020=0.5 METERS
050=5 METERS
200=20 METERS

Overmold color:
Blank= PUR (Standard)
A=Grey / G=Black / Y=Yellow
BLANK = Yellow TPU for cables S19, S20

Contacts:
3=3 Contacts
4=4 Contacts
5=5 Contacts
8=8 Contacts

Cable type:
S20 - Yellow Braided PVC 0.34mm²(22AWG)
P20 - Black Braided PUR 0.34mm²(22AWG)
P19 - Black Braided PUR 0.25mm²(24AWG)
S19 - Yellow Braided PVC 0.25mm²(24AWG)

Coupling Nut Material :
Blank : Standard
1 = Stainless Steel
5= Delrin
7= Teflon Coated
H= 2x ID Carrier

CABLE INFORMATION :

CABLE TYPE	NO. OF WIRES	CROSS SECTION	CABLE JACKET	UL	CSA	STATIC: TEMP. / BENDING RADIUS	DYNAMIC: TEMP. / BENDING RADIUS	DRAG CHAIN	SHIELD
P19	8	0.25mm ²	PUR BLACK	-	-	-40°C to +90°C, >7.5xO.D.	-15°C to +90°C, >12.5xO.D.	2 000 000 cycles, Velocity = 120m/min ; bending 15XO.D.	YES
P20	3/4/5	0.34mm ²	PUR BLACK LSOH	-	-	-40°C to +90°C	-25°C to +90°C	-	YES
S19	8	0.25mm ²	PVC YELLOW	UL 2661	CSA C22.2	-30°C to +105°C, 10xO.D.	-15°C to +105°C, 15xO.D.	2 000 000 cycles , speed =4m/sec	YES
S20	3/4/5	0.34mm ²	PVC YELLOW	UL 2661	1731-CSA	-30°C to +105°C	-40°C to +105°C	-	YES

CABLE LENGTH TOLERANCES

OVER [mm]	UP TO AND INCLUDING [mm]	TOLERANCES [mm]
0	305	+19
305	915	+45
915	1830	+56
1830	3660	+89
3660	7320	+165
7320	14640	+317
14640	30500	+610
30500	>	+2% of finished length

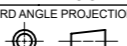
THIS DRAWING CONTAINS INFORMATION THAT IS PROPRIETARY TO MOLEX ELECTRONIC TECHNOLOGIES, LLC AND SHOULD NOT BE USED WITHOUT WRITTEN PERMISSION									
DIMENSION UNITS	SCALE	CURRENT REV DESC: REMOVED OBSOLETE PART NUMBER AS PER PCN#512871.							
mm	1:1	 MICRO-CHANGE ASSEMBLY MALE/FEMALE, SHIELDED 3-8 POLE							
GENERAL TOLERANCES (UNLESS SPECIFIED)									
ANGULAR TOL	± 1.0 °	EC NO: 732259 DRWN: SANTHN 2022/12/15 CHK'D: GGA 2022/12/21 APPR: GGA 2022/12/21							
4 PLACES	±								
3 PLACES	±	INITIAL REVISION: DRWN: RSTONE 2017/01/04 APPR: BWOODMAN 2017/01/18							
2 PLACES	± 0.05								
1 PLACE	± 0.3	DOCUMENT NUMBER		DOC TYPE		DOC PART		REVISION	
0 PLACES	± 0.5	SD-120069-041		PSD		001		A5	
DRAFT WHERE APPLICABLE MUST REMAIN WITHIN DIMENSIONS		THIRD ANGLE PROJECTION	DRAWING	SERIES	MATERIAL NUMBER	CUSTOMER		SHEET NUMBER	
			A3-SIZE	120069	SEE TABLE	GENERAL MARKET		2 OF 3	

DOCUMENT STATUS	P1	RELEASE DATE	2022/12/21	07:37:43
-----------------	----	--------------	------------	----------

PART LIST

No..	MOLEX PN	ENGINEERING NO.	LENGTH
1	1200695045	883S30P20M010	1m
2	1200698080	883S30P20M050	5m
3	1200698035	884S30P20M010	1m
4	1200698036	884S30P20M050	5m
5	1200698128	884S30P20M100	10m
6	1200698129	884S30P20M150	15m
7	1200695054	885S30P20M003	0.3m
8	1200699582	885S30P20M006H	0.6m
9	1200698395	885S30P20M010	1m
10	1200699583	885S30P20M010H	1m
11	1200698342	885S30P20M015	1.5m
12	1200698039	885S30P20M020	2m
13	1200699584	885S30P20M020H	2m
14	1200698448	885S30P20M030	3m
15	1200699585	885S30P20M030H	3m
16	1200698040	885S30P20M050	5m
17	1200699586	885S30P20M050H	5m
18	1200698544	885S30P20M060	6m
19	1200699587	885S30P20M060H	6m
20	1200695053	885S30P20M100	10m
21	1200699588	885S30P20M100H	10m
22	1200698590	885S30P20M120	12m
23	1200699589	885S30P20M150H	15m
24	1200699590	885S30P20M200H	20m
25	1200698140	885S30P20M250	25m
26	1200699591	885S30P20M300H	30m
27	1200699592	885S30P20M350H	35m
28	1200698111	888S30P19M010	1m
29	1200100233	888S30P19M050	5m
30	1200695005	888S30P19M100	10m

NO.	MOLEX PN	ENGINEERING NO.	LENGTH
31	1200695011	888S30P19M250	25m
32	1200100128	883S30S20M050	5m
33	1200100203	884S30S20M100	10m
34	1200698091	888S30S19M010	1m
35	1200699605	885S30P20M070	7m
36	1200699606	885S30P20M055	5.5m
37	1200699703	885S30P20M090	9m
38			
39			
40			
41			

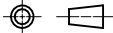
THIS DRAWING CONTAINS INFORMATION THAT IS PROPRIETARY TO MOLEX ELECTRONIC TECHNOLOGIES, LLC AND SHOULD NOT BE USED WITHOUT WRITTEN PERMISSION										
DIMENSION UNITS		SCALE		CURRENT REV DESC: REMOVED OBSOLETE PART NUMBER AS PER PCN#512871.						
mm		1:1								
GENERAL TOLERANCES (UNLESS SPECIFIED)				EC NO: 732259 DRWN: SANTHN 2022/12/15 CHK'D: GGA 2022/12/21 APPR: GGA 2022/12/21						MICRO-CHANGE ASSEMBLY MALE/FEMALE, SHIELDED 3-8 POLE
ANGULAR TOL ± 1.0°								PRODUCT CUSTOMER DRAWING		
4 PLACES ±				INITIAL REVISION: DRWN: RSTONE 2017/01/04 APPR: BWOODMAN 2017/01/18				DOCUMENT NUMBER		
3 PLACES ±								SD-120069-041		DOC TYPE
2 PLACES ± 0.05				DRAFT WHERE APPLICABLE MUST REMAIN WITHIN DIMENSIONS				PSD	001	A5
1 PLACE ± 0.3								THIRD ANGLE PROJECTION	DRAWING	SERIES
0 PLACES ± 0.5					A4-SIZE	120069	SEE TABLE	GENERAL MARKET	3 OF 3	

DOCUMENT STATUS	P1	RELEASE DATE	2022/12/21	07:37:43
-----------------	----	--------------	------------	----------