

NOTES:

1. CONNECTOR MATERIAL:
HOUSING:PBT UL94 V-0
SHIELD:Brass
CONTACT:PHOSPHOR BRONZE
CONTACT PLATING: SELECTIVE GOLD,30 MICRO-INCHS MIN
IN CONTACT AREA
2. PIN NOT ELECTRICALLY CONNECTED MAYBE OMITTED SEE
ELECTRICAL DRAWING FOR OMITTED PINS
3. RJ45 CAVITIES CONFORM TO FCC RULES AND REGULATION
PART 68.
4. THE PART IS RECOMMENDED FOR WAVE SOLDERING
PROCESS PEAK SOLDERING TEMPERATURE IS
260°C MAX, 10 SECS MAX
5. OPERATING TEMPERATURE T=0°C TO +70°C.
6. STORAGE TEMPERATURE T=-40°C TO +85°C.
7. PACKAGING INFORMATION: 50 PCS/ TRAY, 1200 PCS/BOX.

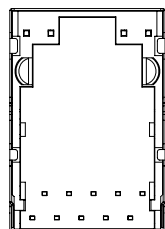
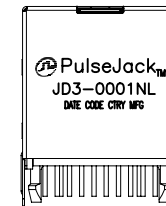
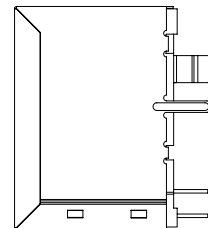
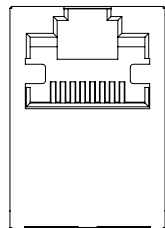

FINAL OUTLINE

© Copyright, 2014. Pulse Electronics Corp. All rights reserved. Pulse confidential & proprietary. (10/14/14)

| PRODUCT DESCRIPTION | TLA DRAWING | PS DRAWING | SHEET | PART NO. | DATASHEET REV. |
|---------------------------|---------------|------------|--------|------------|----------------|
| CONN,RJ45,1X1,100D,1:1,TU | JD3-0001NL-10 | - | 1 OF 5 | JD3-0001NL | A |

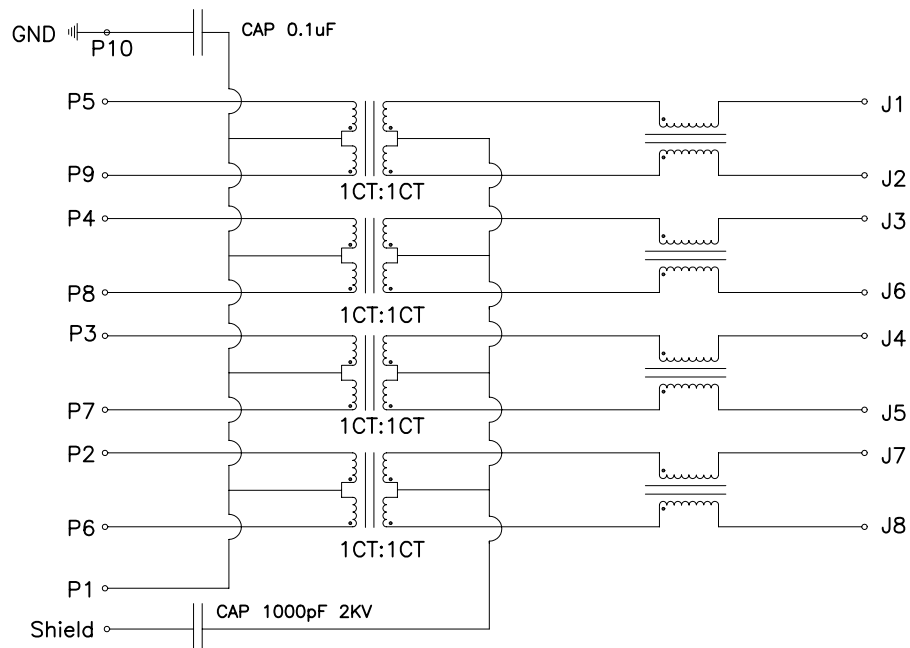

SCHMATIC

Electronical Specifications:

- 1.0 Turn Ratio @100KHz: (P5~P9):(J1~J2) = 1:1±5%
(P4~P8):(J3~J6) = 1:1±5%
(P3~P7):(J4~J5) = 1:1±5%
(P2~P6):(J7~J8) = 1:1±5%
- 2.0 Primary Inductance: 350uH MIN @100KHZ,0.1V 8mA DC BIAS
- 3.0 DC Resistance: 1.2 OHMS MAX
- 4.0 Insertion Loss: 1-125MHz -1.0dB TYP
- 5.0 Return Loss: 1-40MHz -16dB MIN
40-60MHz -12dB MIN
60-80MHz -10dB MIN
80-100MHz -8dB MIN
- 6.0 CROSS TALK: 1-100MHz -30dB MIN
- 7.0 COMMON TO COMMON MODE ATTENUATION: 1-100MHz -30dB MIN
- 8.0 Isolation: PHY Side to Line Side: 2250VDC

© Copyright, 2014. Pulse Electronics Corp. All rights reserved. Pulse confidential & proprietary. (10/14/14)

| PRODUCT DESCRIPTION | TLA DRAWING | PS DRAWING | SHEET | PART NO. | DATASHEET REV. |
|---------------------------|---------------|------------|--------|------------|----------------|
| CONN,RJ45,1X1,100D,1:1,TU | JD3-0001NL-10 | - | 2 OF 5 | JD3-0001NL | A |

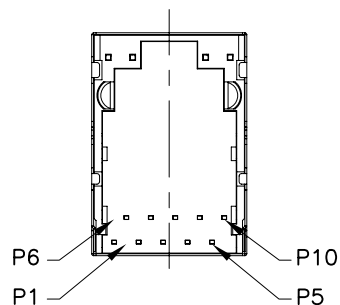
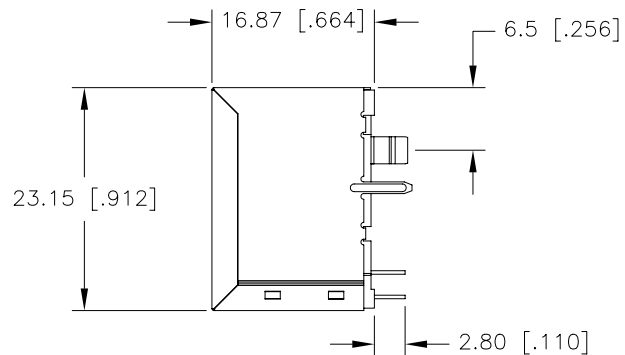
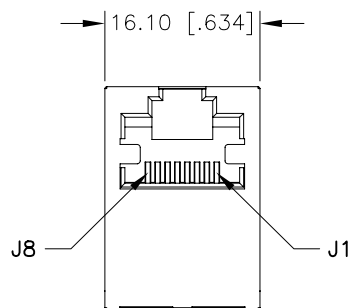

DIMENSIONS ARE IN MILLIMETERS [INCHES] WITH THE FOLLOWING TOLERANCES: [INCHES] ARE FOR REFERENCE ONLY.
X.XX= ±0.25 [±.010]

© Copyright, 2014. Pulse Electronics Corp. All rights reserved. Pulse confidential & proprietary. (10/14/14)

| PRODUCT DESCRIPTION | TLA DRAWING | PS DRAWING | SHEET | PART NO. | DATASHEET REV. |
|---------------------------|---------------|------------|--------|------------|----------------|
| CONN,RJ45,1X1,100D,1:1,TU | JD3-0001NL-10 | - | 3 OF 5 | JD3-0001NL | A |

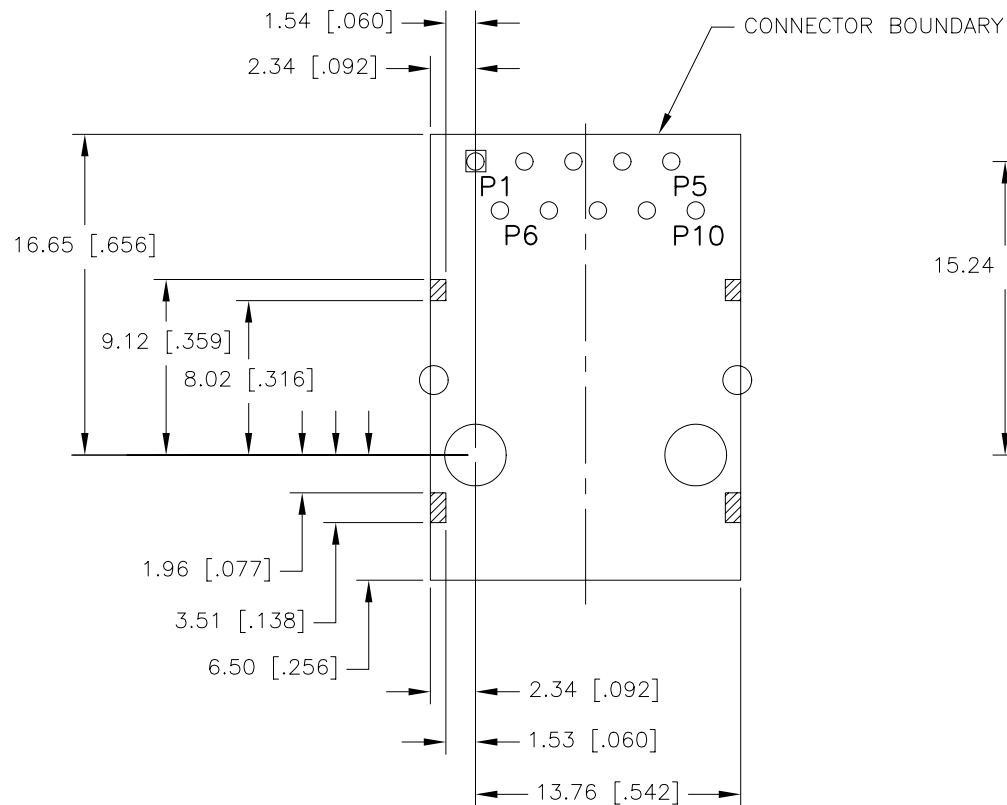

KEEP-OUT AREA (COMPONENT SIDE SHOWN)

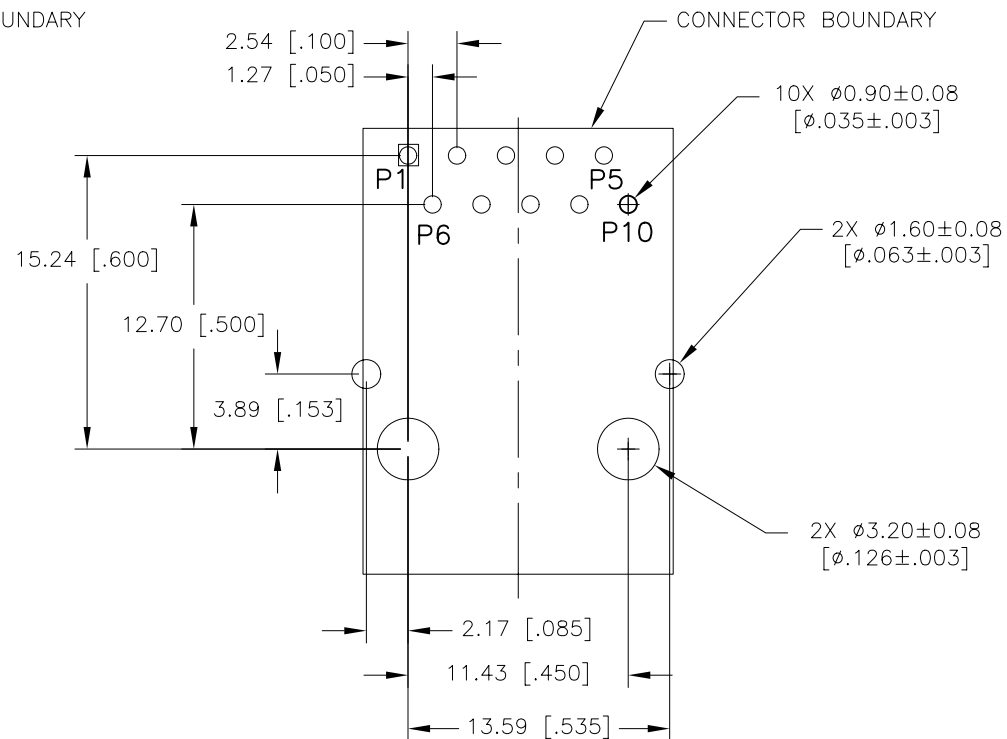

RECOMMENDED PWB LAYOUT
(COMPONENT SIDE SHOWN)

DIMENSIONS ARE IN MILLIMETERS [INCHES] WITH THE FOLLOWING TOLERANCES: [INCHES] ARE FOR REFERENCE ONLY.
X.XX= ± 0.10 [$\pm .004$]

© Copyright, 2014. Pulse Electronics Corp. All rights reserved. Pulse confidential & proprietary. (10/14/14)

| PRODUCT DESCRIPTION | TLA DRAWING | PS DRAWING | SHEET | PART NO. | DATASHEET REV. |
|---------------------------|---------------|------------|--------|------------|----------------|
| CONN,RJ45,1X1,100D,1:1,TU | JD3-0001NL-10 | - | 4 OF 5 | JD3-0001NL | A |

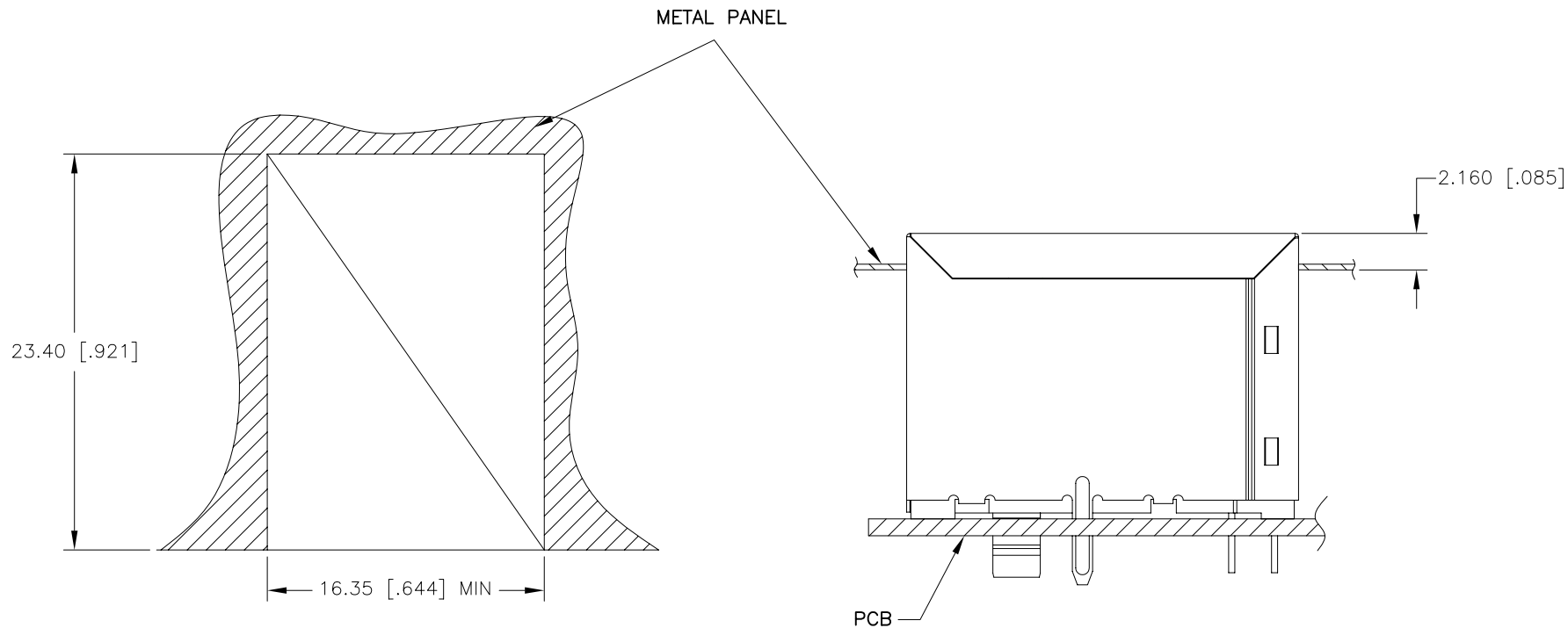

SUGGESTED PANEL CUTOUT

DIMENSIONS ARE IN MILLIMETERS [INCHES] WITH THE FOLLOWING TOLERANCES: [INCHES] ARE FOR REFERENCE ONLY.
X.XX= ± 0.10 [± 0.004]

© Copyright, 2014. Pulse Electronics Corp. All rights reserved. Pulse confidential & proprietary. (10/14/14)

| PRODUCT DESCRIPTION | TLA DRAWING | PS DRAWING | SHEET | PART NO. | DATASHEET REV. |
|---------------------------|---------------|------------|--------|------------|----------------|
| CONN,RJ45,1X1,100D,1:1,TU | JD3-0001NL-10 | - | 5 OF 5 | JD3-0001NL | A |