

PART NUMBER	REVISION	DESCRIPTION	FEED TYPE
2151466-1	M	FINE CRIMP HEIGHT ADJUST	MECHANICAL
2151466-2	M	FINE CRIMP HEIGHT ADJUST	PNEUMATIC
5-2151466-1	M	SEAL STRIPPER CRIMPER TERMINATING UNIT	MECHANICAL
5-2151466-2	M	SEAL STRIPPER CRIMPER TERMINATING UNIT	PNEUMATIC
7-2151466-1	M	MECHANICAL AND CRIMP TOOLING KIT	MECHANICAL
7-2151466-2	M	PNEUMATIC AND CRIMP TOOLING KIT	PNEUMATIC
7-2151466-7	J	CRIMP TOOLING KIT	-

ATLANTIC VERSION TERMINATOR INTERFACE ADAPTER



APPLICATOR DATA		
CRIMP	SIZE	TYPE
WIRE	4.07 mm [.160]	F
INSUL	6.86 mm [.270]	O

APPLICATOR INSTRUCTIONS
408-35042

TERMINAL DATA: TE TERMINAL		TE CRIMP SPECIFICATION	
TERMINAL NAME: AMP MCP 6.3/4.8K RECEPTACLE			
WIRE STRIP LENGTH	TERMINAL INSULATION DIAMETER RANGE		
5.10-5.70 mm [.201-.224 IN]	Ø 3.4-4.3mm [.134-.169 IN]		
TERMINAL APPLICATION SPECIFICATION	114-18388		

TERMINALS APPLIED				SEAL INSULATION DIAMETER RANGE
TE TERMINAL	TE TERMINAL	VW SEAL	TE SEAL	
1241418-4	1-1241418-3		1394512-1	Ø 3.4-3.7mm
2-1241418-3	1-2327632-3		1719043-1	Ø 4.0-4.5mm
		357972742C	1572663-1	Ø 4.0-4.5mm
		357973742C	1572663-2	Ø 4.0-4.5mm

WIRE SIZE	CRIMP HEIGHT mm [INCH]	CRIMP HEIGHT REFERENCE SETTING
6.00mm2	2.58+/-0.05 [.102+/-0.002]	5.5
5.00mm2	2.21+/-0.05 [.087+/-0.002]	8.3
4.00mm2	2.06+/-0.05 [.081+/-0.002]	9.8

- △ RECOMMENDED SPARE PARTS
- △ REFER TO SUPPLIED INSTRUCTION SHEET FOR CLEANING, LUBRICATION & STORAGE OF APPLICATOR.
- △ APPLY PART NUMBER 2-23419-6 LOCTITE TO THREADS OF ITEM 242.
- △ CRIMP HEIGHT REFERENCE SETTING WAS THE SETTING USED WHEN THE APPLICATOR WAS QUALIFIED AT THE FACTORY. ADJUSTMENT MAY BE NECESSARY WHEN RUNNING APPLICATOR IN THE FIELD.
- △ APPLY TORQ-SEAL IN ALLEN SOCKET TO FILL HOLE AFTER FLAT HD HAS BEEN ADJUSTED TO CORRECT HEIGHT AT QUALIFICATION. APPLY #1-23419-5 LOC-TITE TO THREADS.
- △ TERMINAL LUBRICANT IS RECOMMENDED.
- 7. UNLESS SPECIFIED OTHERWISE TORQUE VALUES SHALL BE USED PER DOCUMENT, 101-35000.
- △ THIS CRIMP PARAMETER IS PROVIDED TO MEET A CUSTOM AND UNIQUE CUSTOMER REQUIREMENT. IT HAS BEEN EVALUATED AND IS CONDITIONALLY SPECIFIED BY TE CONNECTIVITY. THIS CUSTOMIZED CRIMP PARAMETER IS NOT LISTED AS AN APPROVED APPLICATION WITHIN A TE CONNECTIVITY APPLICATION SPECIFICATION; HOWEVER, IT HAS BEEN VALIDATED ACCORDING TO TE CONNECTIVITY SPECIFICATIONS 109-18079(TEST GROUP 1) AND 114-18022. TE CONNECTIVITY EXPRESSLY DISCLAIMS ANY AND ALL WARRANTIES THAT THE PRODUCT WILL PERFORM SIMILARLY

***WARNING**
ON INSTALLATION, SET WIRE DISC TO CRIMP HEIGHT REFERENCE SETTING FOR LARGEST WIRE SIZE. CRIMP HEIGHT REFERENCE SETTINGS GREATER THAN THE VALUE SHOWN MAY CAUSE DAMAGE TO THE CRIMP TOOLING, REFER TO THE INSTRUCTION SHEET FOR PROPER SETUP AND ADJUSTMENTS.

ATLANTIC VERSION
Shown on sheets 1 of 4 & 2 of 4
(Pacific version shown on sheets 3 of 4 & 4 of 4)

LOC	DIST	REVISIONS					
A	66	P	LTN	DESCRIPTION	DATE	OWN	APPD
		K1		ECR-20-010237	20JUL2020	FZ	RK
		K2		ECR-21-112514	02SEP2021	JWC	TE
		L		ECR-21-120638	12NOV2021	FZ	TE
		M		ECR-22-133774	24MAR2022	LG	TE

-	1	1	-	-	1	1	1803382-4	HOLD DOWN, SPRING LOADED	301
-	-	-	1	1	-	-	22278-9	SPRING, COMPRESSION	300
-	-	-	2	2	-	-	4-18032-3	SCR, SET, FLT PNT, M3 X 6.0	299
-	-	-	1	1	-	-	1803945-4	TONKER	298
-	-	-	1	1	-	-	1803944-1	SPACER, TONKER	297
-	-	-	1	1	-	-	2-1803583-1	APPLICATOR BASIC ASSEMBLY, SF	292
-	1	-	1	-	1	-	2119641-1	FEED CAM, AIR FEED	248
-	1	1	1	1	1	1	2119082-8	CAM, SNAIL, INSULATION ADJUSTMENT	244
-	1	1	1	1	1	1	2079764-1	WASHER, WAVE SPRING, CREST-TO-CREST	243
△	1	1	1	1	1	1	2119083-1	RETAINER, INSULATION DIAL	242
-	1	1	1	1	1	1	7-18023-7	SCR, SKT HD CAP M3 X 4.0	241
-	-	1	-	1	-	1	2119580-1	MECHANICAL FEED ASSEMBLY	239
-	1	-	1	-	1	-	2844940-1	AIR FEED MODULE	238
-	REF	REF	REF	REF	REF	REF	994970-2	COUNTER, MAGNETIC	164
-	1	1	1	1	1	1	1-18028-2	WASHER, FLAT, REG M4	119
△	1	1	1	1	1	1	2119955-1	ASSY, LUBRICATOR, SIDE FEED	113
-	1	1	1	1	1	1	2844908-1	SCREW, LOCKING	99
-	1	1	1	1	1	1	2844907-1	POST, LOCKING	98
-	1	1	1	1	1	1	455888-7	SPACER, CRIMPER	82
-	1	1	1	1	1	1	1803607-3	DOCUMENTATION PACKAGE	71
-	1	1	1	1	1	1	2119791-5	DEPRESSOR, WIRE	70
-	1	1	1	1	1	1	2119943-1	WASHER, SPACER	69
-	1	1	1	1	1	1	2119740-1	TAG, IDENTIFICATION	67
-	2	2	2	2	2	2	2168078-1	SCREW, DRIVE, RH, RoHS, 2 x .188	66
-	1	1	1	1	1	1	2168083-2	SCR, SKT HD CAP, RoHS, M4 X 8.0	60
-	1	1	1	1	1	1	5-18022-5	SCR, HEX HD CAP, M4 X 6.0	59
△	1	1	1	1	1	1	985575-3	SCR, FLT SKT HD CAP M3 X 10.0	57
-	1	1	1	1	1	1	1338685-1	PAWL, FEED	56
-	4	4	4	4	4	4	2168083-3	SCR, SKT HD CAP, RoHS, M4 X 12.0	54
-	2	2	2	2	2	2	2168083-3	SCR, SKT HD CAP, RoHS, M4 X 12.0	53
-	1	2	1	2	1	2	18023-9	SCR, SKT HD CAP M4 X 6.0	49
-	-	1	-	1	-	1	2119652-1	FEED CAM, PRE FEED	48
-	-	1	-	1	-	1	2119653-1	FEED CAM, POST FEED	47
-	1	1	-	-	1	1	1803583-9	APPLICATOR BASIC ASSEMBLY, SF	46
-	1	1	1	1	1	1	1803515-1	RAM ASSEMBLY, SF ATLANTIC	44
-	1	1	1	1	1	1	1803602-1	SCR, BHSC, RoHS (M8 X 25)	41
-	1	1	1	1	1	1	1-1752356-5	SUPPORT, TERMINAL	34
-	2	2	2	2	2	2	1-2079383-3	SCR, BHSC, RoHS (M4 X 25)	33
-	2	2	2	2	2	2	3-2844962-5	SPACER, CYLINDRICAL, STRIP GUIDE	30
-	1	1	1	1	1	1	2844992-2	ASSEMBLY, STRIP GUIDE	29
-	1	1	1	1	1	1	455888-3	SPACER, CRIMPER	28
-	1	1	1	1	1	1	1320928-2	STRIP GUIDE	24
-	1	1	-	-	1	1	2168083-2	SCR, SKT HD CAP, RoHS, M4 X 8.0	21
-	2	2	1	1	2	2	1-18028-2	WASHER, FLAT, REG M4	20
-	1	1	-	-	1	1	1803013-1	STRIPPER, SIDE FEED	19
△	1	1	1	1	1	1	2119806-1	INSERT, SHEAR	13
-	1	1	1	1	1	1	3-22280-3	SPRING, COMPRESSION	12
-	1	1	1	1	1	1	1-356885-4	STOP, SHEAR	11
△	1	1	1	1	1	1	2119805-1	SHEAR HOLDER, FRONT	10
△	1	1	1	1	1	1	318707-1	FLOATING SHEAR, FRONT	9
△	1	2	2	1	1	1	1333229-9	ANVIL, COMBINATION	8
-	1	1	1	1	1	1	3-240641-3	SPACER	7
-	1	1	1	1	1	1	1-2119781-0	DEPRESSOR, SHEAR	5
-	1	1	1	1	1	1	238011-2	BLOCK, CRIMPER SPACER	4
△	1	2	2	1	1	1	6-1633996-5	CRIMPER, INSULATION SPECIAL	3
-	1	1	1	1	1	1	455888-3	SPACER, CRIMPER	2
△	1	2	2	1	1	1	8-458141-0	CRIMPER, WIRE PREMIUM	1

ITEM NO	PART NO	DESCRIPTION	ITEM NO
-77	-72	-71	-52
-51	-2	-1	
TE CONNECTIVITY COMPANY		TE Connectivity	
114-18022-5		Harrisburg, PA 17105-3608	
DIMENSIONS:		TOLERANCES UNLESS OTHERWISE SPECIFIED:	
mm	0 PLC ±	1 PLC ±	
	2 PLC ±	3 PLC ±	
	4 PLC ±	ANGLES ±	
MATERIAL	FINISH	WEIGHT	
Customer Accessible Production Drawing		SCALE 1:2	SHEET 1 OF 4

LOC	DIST	REVISIONS					
A	66	P	LTN	DESCRIPTION	DATE	OWN	APVD
-	-	-	-	SEE SHEET 1	-	-	-

FEED TYPE MECHANICAL

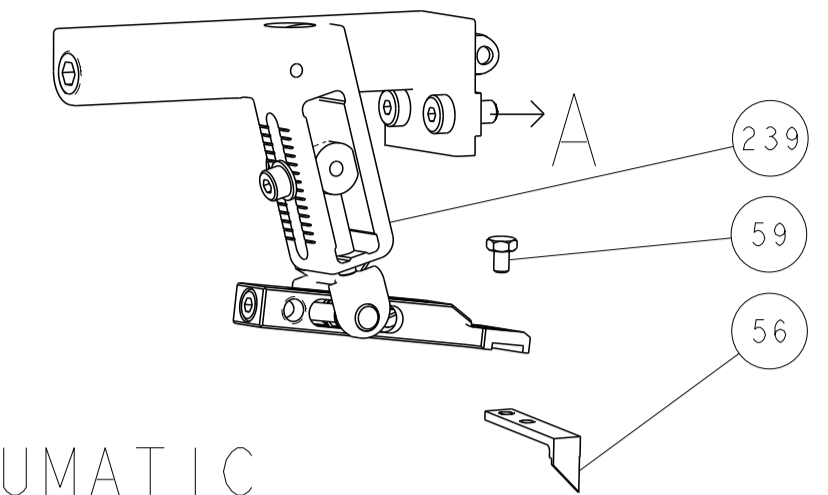

PNEUMATIC

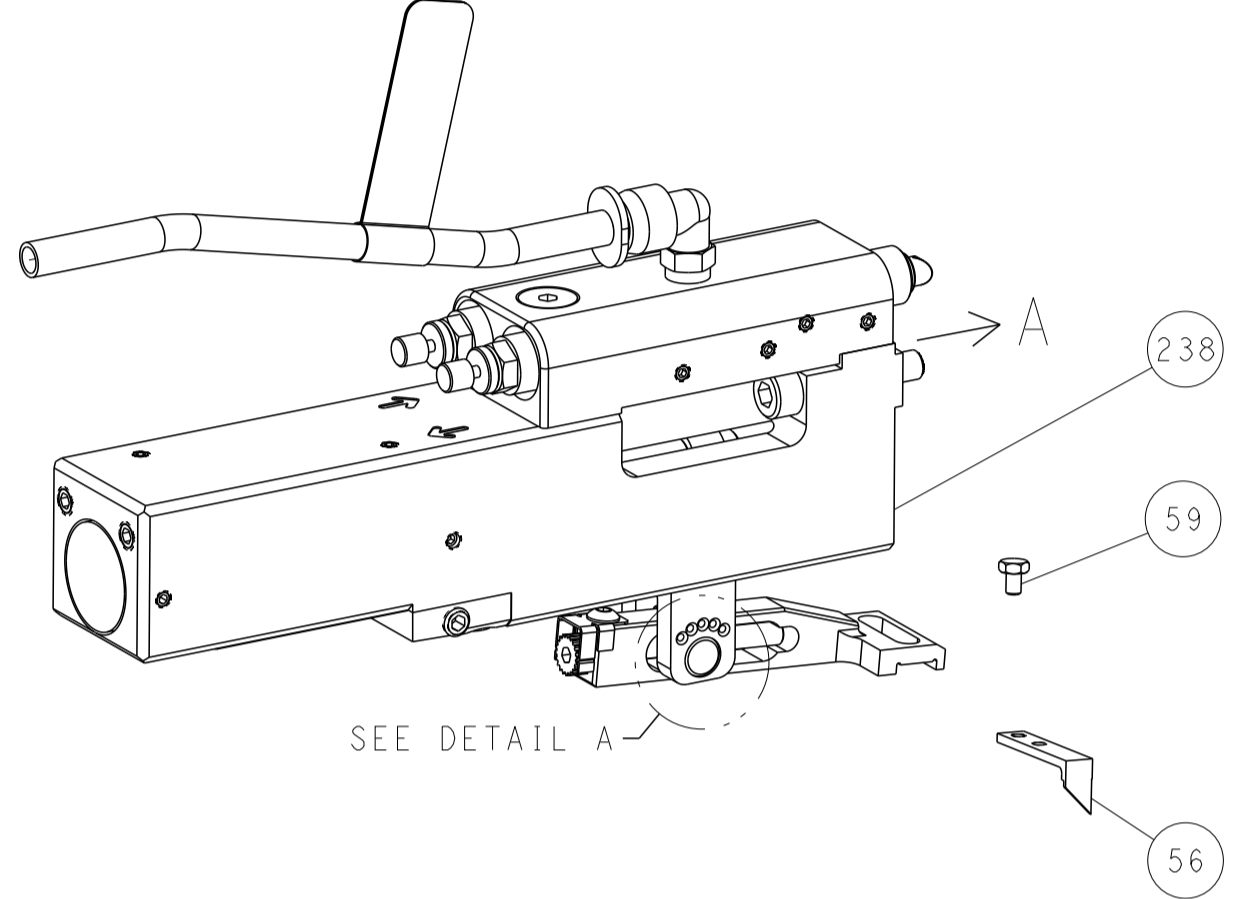

FEED SPRING SETTING POSITION (SHOWN FROM REAR SIDE)



DETAIL A

CAM POSITIONS

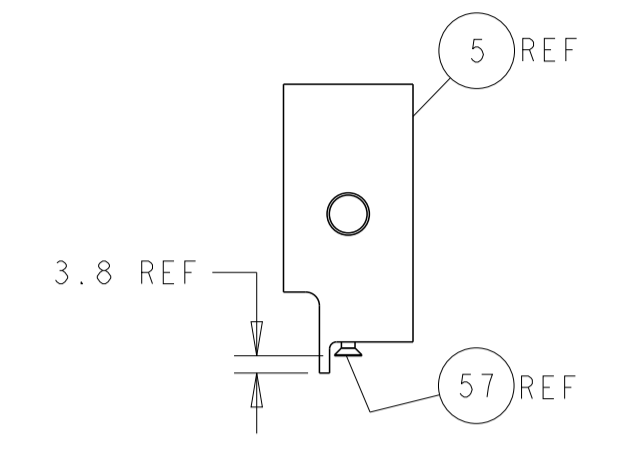
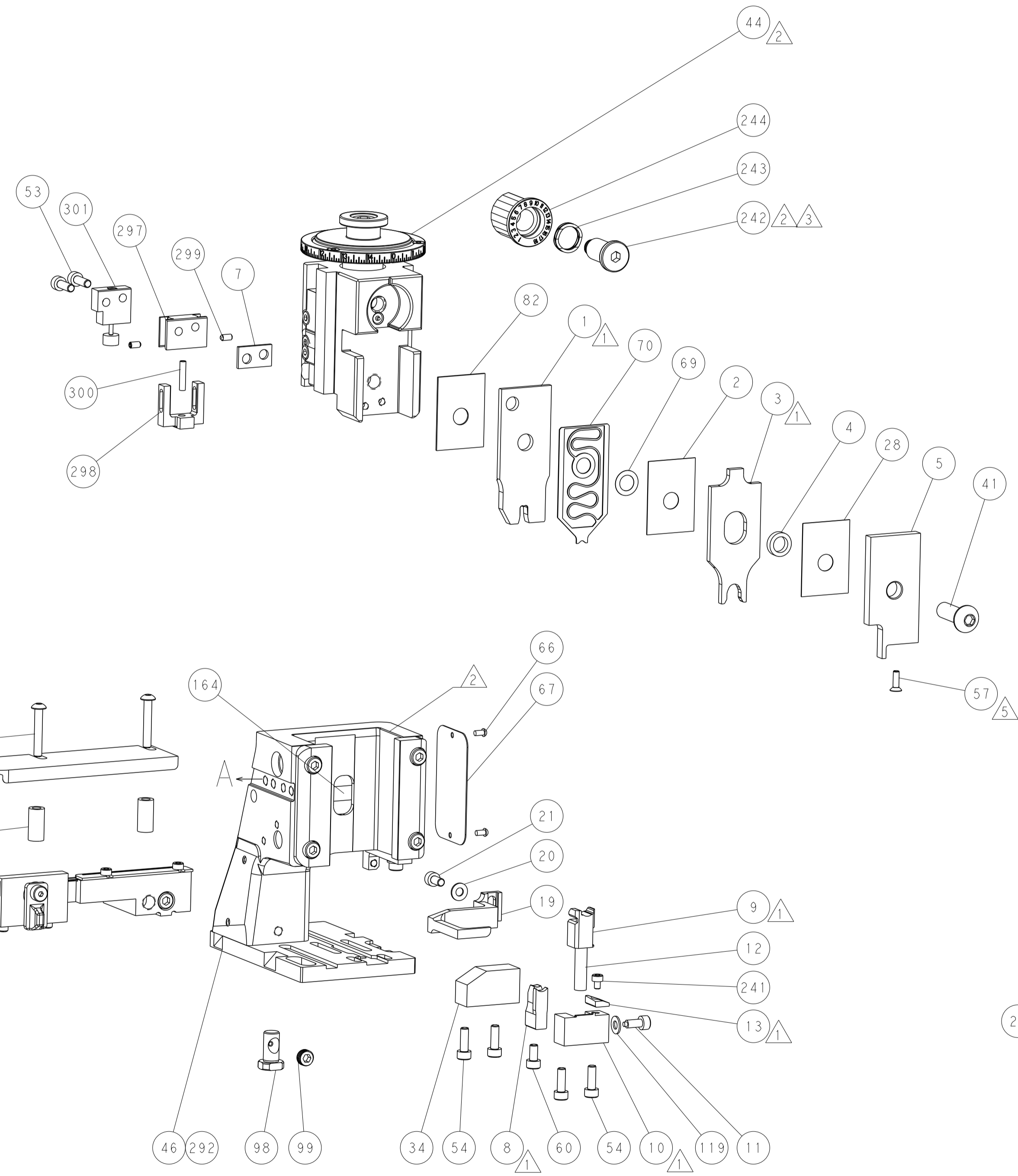
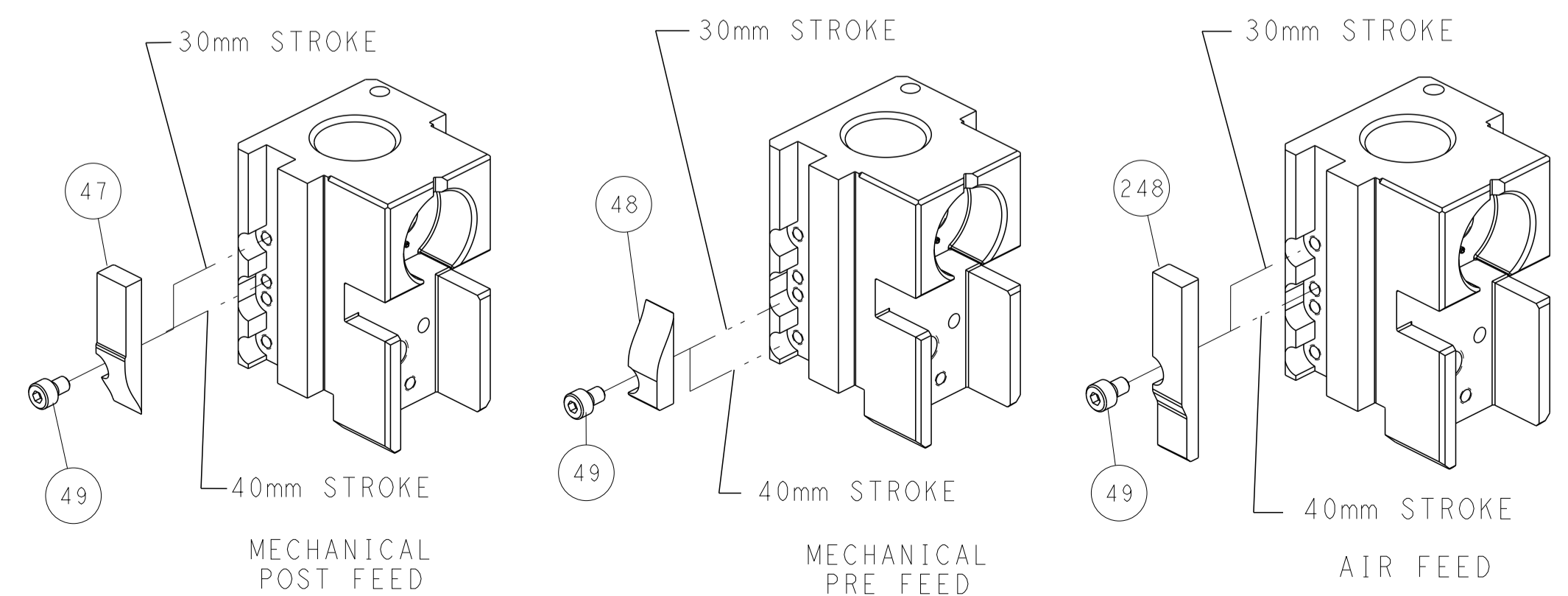

SHEAR DEPRESSOR DETAIL

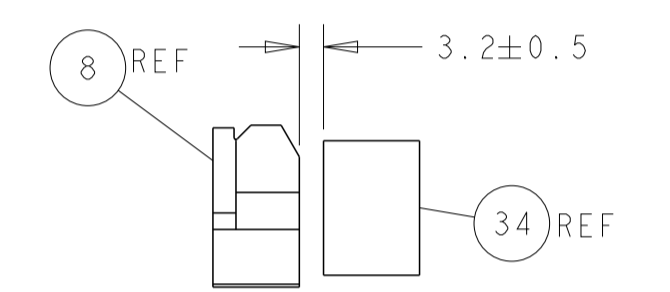

TERMINAL SUPPORT LOCATION

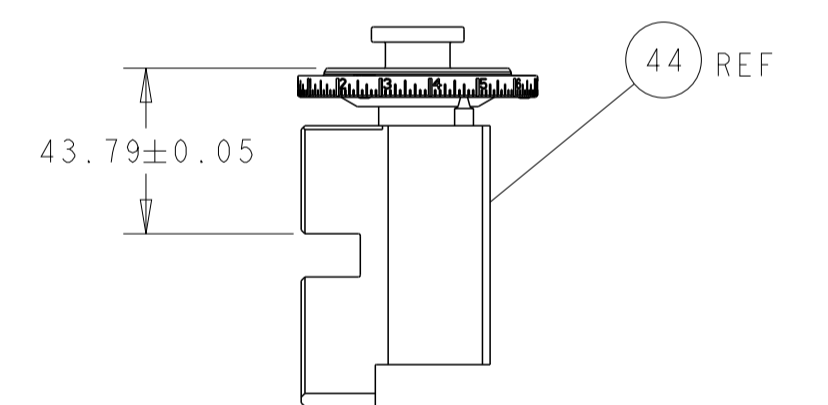

RAM SET-UP

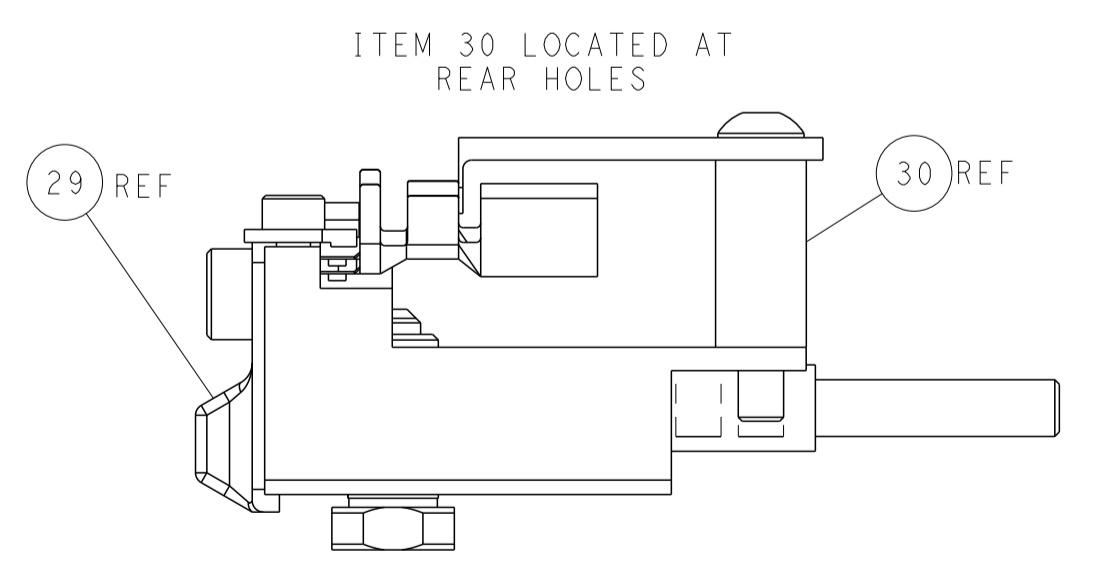

FEED TRACK POSITION GUIDE BY WIRE BARREL

ATLANTIC VERSION
 Shown on sheets 1 of 4 & 2 of 4
 (Pacific version shown on sheets 3 of 4 & 4 of 4)

DIMENSIONS: mm 		TOLERANCES UNLESS OTHERWISE SPECIFIED: 0 PLC ± 1 PLC ± 2 PLC ± 3 PLC ± 4 PLC ± ANGLES ± FINISH		DWN L. ZHANG 16AUG2011 CHK L. ZHANG 16AUG2011 S. XI 16AUG2011 APVD S. XI 16AUG2011 NAME Ocean Side Feed Applicator SIZE CAGE CODE DRAWING NO. RESTRICTED TO A1 00779 ©=2151466 Customer Accessible Production Drawing SCALE 1:2 SHEET 2 OF 4 REV M	
THIS DRAWING IS UNPUBLISHED. RELEASED FOR PUBLICATION. ALL RIGHTS RESERVED.				TE Connectivity Harrisburg, PA 17105-3608	

PART NUMBER	REVISION	DESCRIPTION	FEED TYPE
2-2151466-1	M	FINE CRIMP HEIGHT ADJUST	MECHANICAL
2-2151466-2	M	FINE CRIMP HEIGHT ADJUST	PNEUMATIC
7-2151466-7	J	CRIMP TOOLING KIT	-

PACIFIC VERSION TERMINATOR
INTERFACE ADAPTER



APPLICATOR DATA		
CRIMP	SIZE	TYPE
WIRE	4.07 mm [1.160]	F
INSUL	6.86 mm [1.270]	O

APPLICATOR INSTRUCTIONS
408-35042

TERMINAL DATA: TE TERMINAL		TE CRIMP SPECIFICATION	
TERMINAL NAME: AMP MCP 6.3/4.8K RECEPTACLE			
WIRE STRIP LENGTH	TERMINAL INSULATION DIAMETER RANGE		
5.10-5.70 mm [1.201-.224 IN]	∅ 3.4-4.3mm [1.34-.169 IN]		
TERMINAL APPLICATION SPECIFICATION	114-18388		

TERMINALS APPLIED				SEAL INSULATION DIAMETER RANGE
TE TERMINAL	TE TERMINAL	VW SEAL	TE SEAL	
1241418-4	1-1241418-3		1394512-1	∅ 3.4-3.7mm
2-1241418-3	1-2327632-3		1719043-1	∅ 4.0-4.5mm
		357972742C	1572663-1	∅ 4.0-4.5mm
		357973742C	1572663-2	∅ 4.0-4.5mm

WIRE SIZE	CRIMP HEIGHT mm [INCH]	CRIMP HEIGHT REFERENCE SETTING
6.00mm2	2.58+/-0.05 [1.102+/-0.002]	5.5
5.00mm2	2.21+/-0.05 [1.087+/-0.002]	8.3
4.00mm2	2.06+/-0.05 [1.081+/-0.002]	9.8



- 1 RECOMMENDED SPARE PARTS
- 2 REFER TO SUPPLIED INSTRUCTION SHEET FOR CLEANING, LUBRICATION & STORAGE OF APPLICATOR.
- 3 APPLY PART NUMBER 2-23419-6 LOCTITE TO THREADS OF ITEM 242.
- 4 CRIMP HEIGHT REFERENCE SETTING WAS THE SETTING USED WHEN THE APPLICATOR WAS QUALIFIED AT THE FACTORY. ADJUSTMENT MAY BE NECESSARY WHEN RUNNING APPLICATOR IN THE FIELD.
- 5 APPLY TORO-SEAL IN ALLEN SOCKET TO FILL HOLE AFTER FLAT HD HAS BEEN ADJUSTED TO CORRECT HEIGHT AT QUALIFICATION. APPLY #1-23419-5 LOC-TITE TO THREADS.
- 6 TERMINAL LUBRICANT IS RECOMMENDED.
- 7. UNLESS SPECIFIED OTHERWISE TORQUE VALUES SHALL BE USED PER DOCUMENT, 101-35000.
- 8 THIS CRIMP PARAMETER IS PROVIDED TO MEET A CUSTOM AND UNIQUE CUSTOMER REQUIREMENT. IT HAS BEEN EVALUATED AND IS CONDITIONALLY SPECIFIED BY TE CONNECTIVITY. THIS CUSTOMIZED CRIMP PARAMETER IS NOT LISTED AS AN APPROVED APPLICATION WITHIN A TE CONNECTIVITY APPLICATION SPECIFICATION; HOWEVER, IT HAS BEEN VALIDATED ACCORDING TO TE CONNECTIVITY SPECIFICATIONS 109-18079 (TEST GROUP 1) AND 114-18022. TE CONNECTIVITY EXPRESSLY DISCLAIMS ANY AND ALL WARRANTIES THAT THE PRODUCT WILL PERFORM SIMILARLY

***WARNING**
ON INSTALLATION, SET WIRE DISC TO CRIMP HEIGHT REFERENCE SETTING FOR LARGEST WIRE SIZE. CRIMP HEIGHT REFERENCE SETTINGS GREATER THAN THE VALUE SHOWN MAY CAUSE DAMAGE TO THE CRIMP TOOLING, REFER TO THE INSTRUCTION SHEET FOR PROPER SETUP AND ADJUSTMENTS.

PACIFIC VERSION
Shown on sheets 3 of 4 & 4 of 4
(Atlantic version shown on sheets 1 of 4 & 2 of 4)

LOC	DIST	REVISIONS					
A	66	P	LTN	DESCRIPTION	DATE	OWN	APVD
		-		SEE SHEET 1			

-	1	1	1803382-4	HOLD DOWN, SPRING LOADED	301	
-	1	1	2119082-8	CAM, SNAIL, INSULATION ADJUSTMENT	244	
-	1	1	2079764-1	WASHER, WAVE SPRING, CREST-TO-CREST	243	
3	-	1	1	2119083-1	RETAINER, INSULATION DIAL	242
-	1	1	7-18023-7	SCR, SKT HD CAP M3 X 4.0	241	
-	-	1	1	2119580-1	MECHANICAL FEED ASSEMBLY	239
-	1	-	2844940-1	AIR FEED MODULE	238	
-	REF	REF	994970-2	COUNTER, MAGNETIC	164	
-	1	-	2119641-2	FEED CAM, AIR FEED	151	
-	1	1	2168083-8	SCR, SKT HD CAP, RoHS, M4 X 16	144	
-	4	4	2168083-9	SCR, SKT HD CAP, RoHS, M4 X 20	143	
-	-	1	2119653-2	FEED CAM, POST FEED	142	
-	1	1	1-1803583-0	APPLICATOR BASIC ASSEMBLY, SF	141	
-	1	1	1803516-1	RAM ASSEMBLY, SF PACIFIC	140	
-	1	1	1-18028-2	WASHER, FLAT, REG M4	119	
6	-	1	1	2119955-1	ASSY, LUBRICATOR, SIDE FEED	113
-	1	1	2844908-1	SCREW, LOCKING	99	
-	1	1	2844907-1	POST, LOCKING	98	
-	1	1	455888-7	SPACER, CRIMPER	82	
-	1	1	1803607-3	DOCUMENTATION PACKAGE	71	
-	1	1	2119791-5	DEPRESSOR, WIRE	70	
-	1	1	2119943-1	WASHER, SPACER	69	
-	1	1	2119740-1	TAG, IDENTIFICATION	67	
-	2	2	2168078-1	SCREW, DRIVE, RH, RoHS, 2 x .188	66	
-	1	1	5-18022-5	SCR, HEX HD CAP, M4 X 6.0	59	
5	-	1	1	985575-3	SCR, FLT SKT HD CAP M3 X 10.0	57
-	1	1	1338685-1	PAWL, FEED	56	
-	2	2	2168083-3	SCR, SKT HD CAP, RoHS, M4 X 12.0	53	
-	1	2	18023-9	SCR, SKT HD CAP M4 X 6.0	49	
-	-	1	2119652-1	FEED CAM, PRE FEED	48	
-	1	1	1803602-1	SCR, BHSC, RoHS (M8 X 25)	41	
-	1	1	1-1752356-5	SUPPORT, TERMINAL	34	
-	2	2	1-2079383-3	SCR, BHSC, RoHS (M4 X 25)	33	
-	2	2	3-2844962-5	SPACER, CYLINDRICAL, STRIP GUIDE	30	
-	1	1	2844992-2	ASSEMBLY, STRIP GUIDE	29	
-	1	1	455888-3	SPACER, CRIMPER	28	
-	1	1	1320928-2	STRIP GUIDE	24	
-	1	1	2168083-2	SCR, SKT HD CAP, RoHS, M4 X 8.0	21	
-	1	1	1-18028-2	WASHER, FLAT, REG M4	20	
-	1	1	1803013-1	STRIPPER, SIDE FEED	19	
1	-	1	1	2119806-1	INSERT, SHEAR	13
-	1	1	3-22280-3	SPRING, COMPRESSION	12	
-	1	1	1-356885-4	STOP, SHEAR	11	
1	-	1	1	2119805-1	SHEAR HOLDER, FRONT	10
1	-	1	1	318707-1	FLOATING SHEAR, FRONT	9
1	-	1	1	1333229-9	ANVIL, COMBINATION	8
-	1	1	3-240641-3	SPACER	7	
-	1	1	1-2119781-0	DEPRESSOR, SHEAR	5	
-	1	1	238011-2	BLOCK, CRIMPER SPACER	4	
1	-	1	1	6-1633996-5	CRIMPER, INSULATION SPECIAL	3
-	1	1	455888-3	SPACER, CRIMPER	2	
1	-	1	1	8-458141-0	CRIMPER, WIRE PREMIUM	1
-77	-22	-21	PART NO	DESCRIPTION	ITEM NO	

<small>THIS DRAWING IS CONDITIONALLY SPECIFIED BY THE CUSTOMER'S REQUIREMENT. IT IS SUBJECT TO CHANGE AND TO THE APPLICATOR'S INSTRUCTIONS. THE CUSTOMER SHOULD BE CONTACTED FOR THE LATEST VERSION.</small>		DWN L. ZHANG 16AUG2011 CHK L. ZHANG 16AUG2011 APVD S. XI 16AUG2011	TE Connectivity Harrisburg, PA 17105-3608
DIMENSIONS: mm 		TOLERANCES UNLESS OTHERWISE SPECIFIED: 0 PLC ± 1 PLC ± 2 PLC ± 3 PLC ± 4 PLC ± ANGLES ± FINISH	NAME: Ocean Side Feed Applicator SIZE: A1 CAGE CODE: 00779 DRAWING NO: C=2151466 RESTRICTED TO: M
MATERIAL: -		WEIGHT: -	SCALE: 1:2 SHEET 3 OF 4 REV M

LOC		DIST		REVISIONS			
A	66	P	LTM	DESCRIPTION	DATE	OWN	APVD
-	-	-	-	SEE SHEET 1	-	-	-

FEED TYPE MECHANICAL

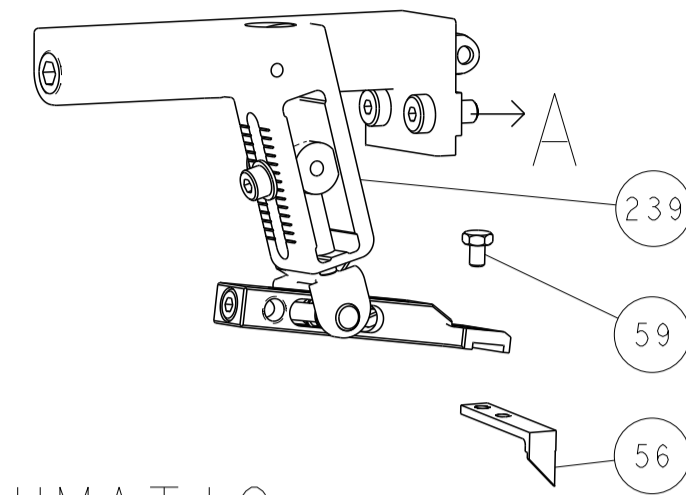

PNEUMATIC

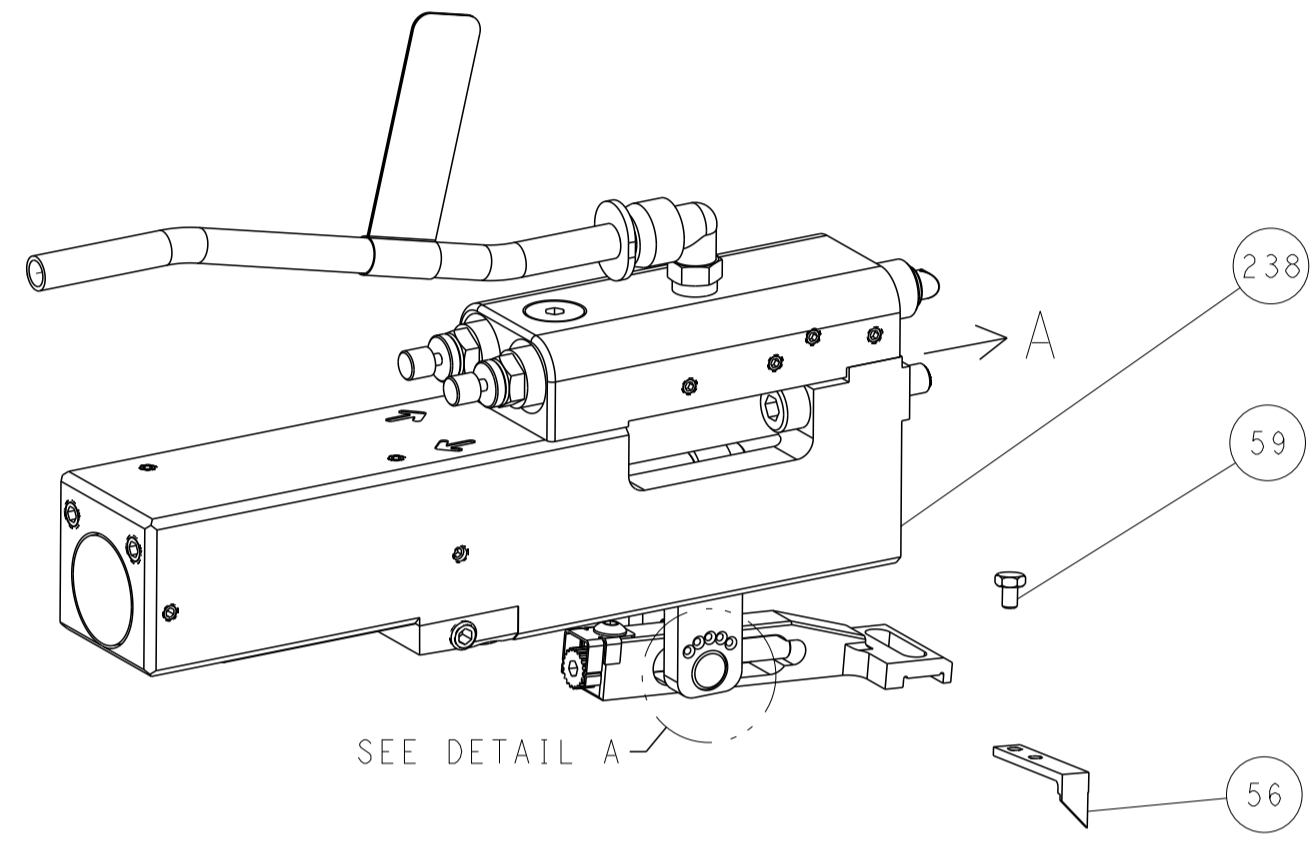

FEED SPRING SETTING POSITION (SHOWN FROM REAR SIDE)

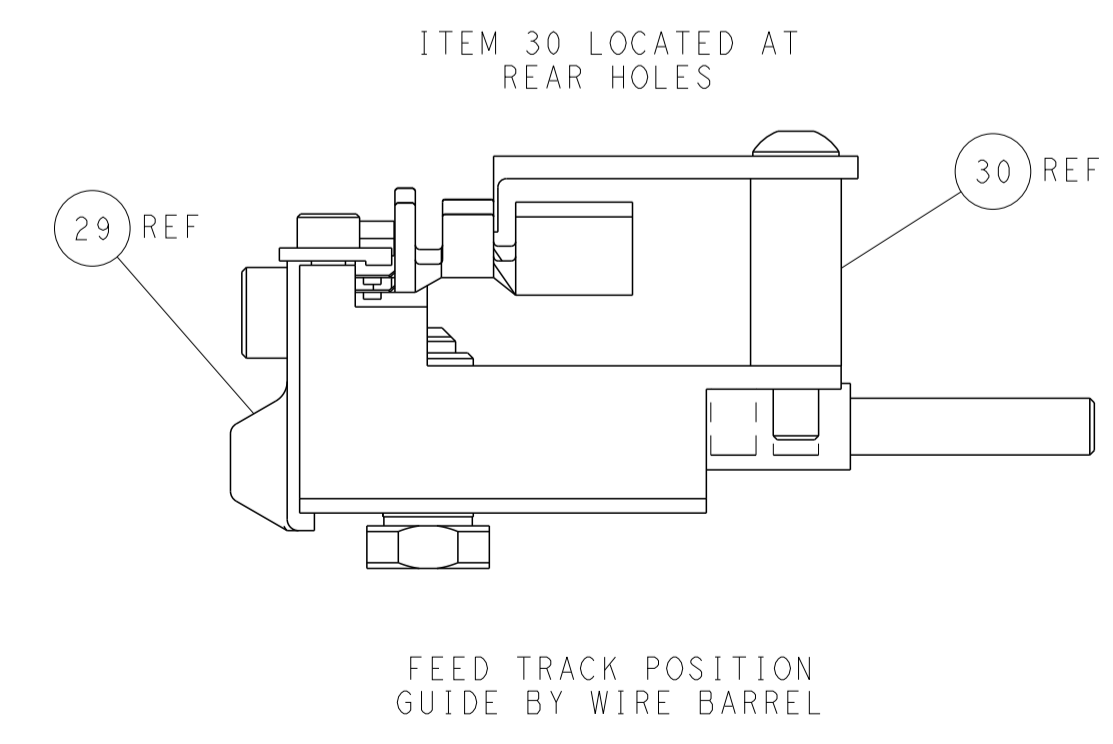
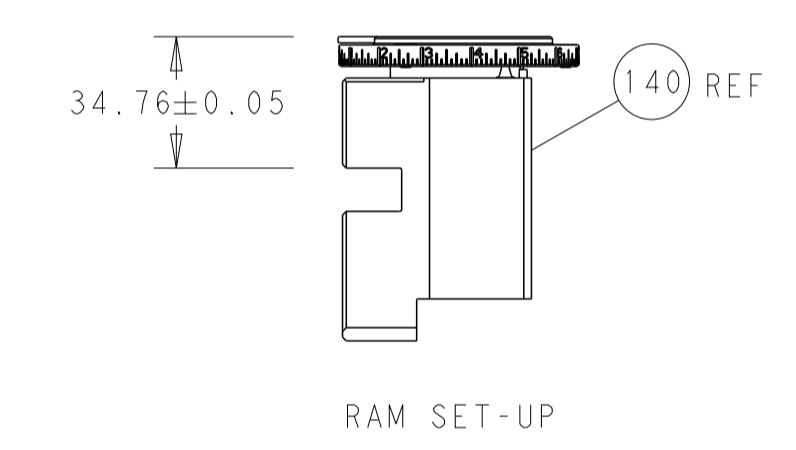
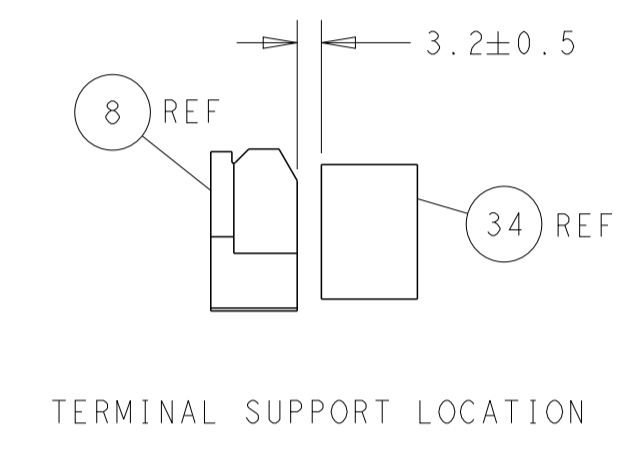
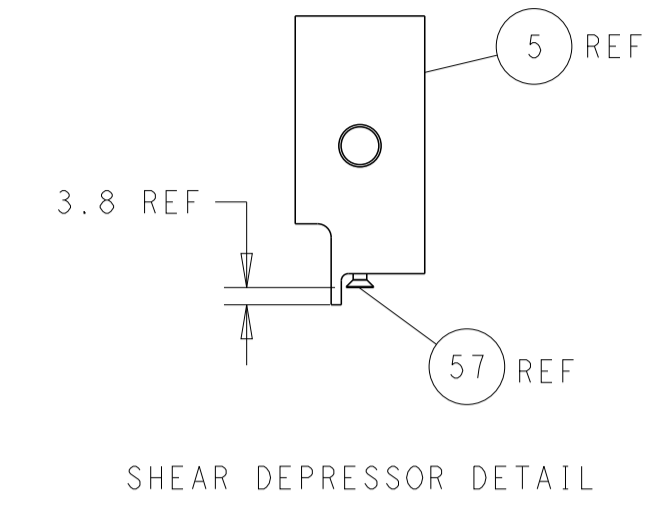
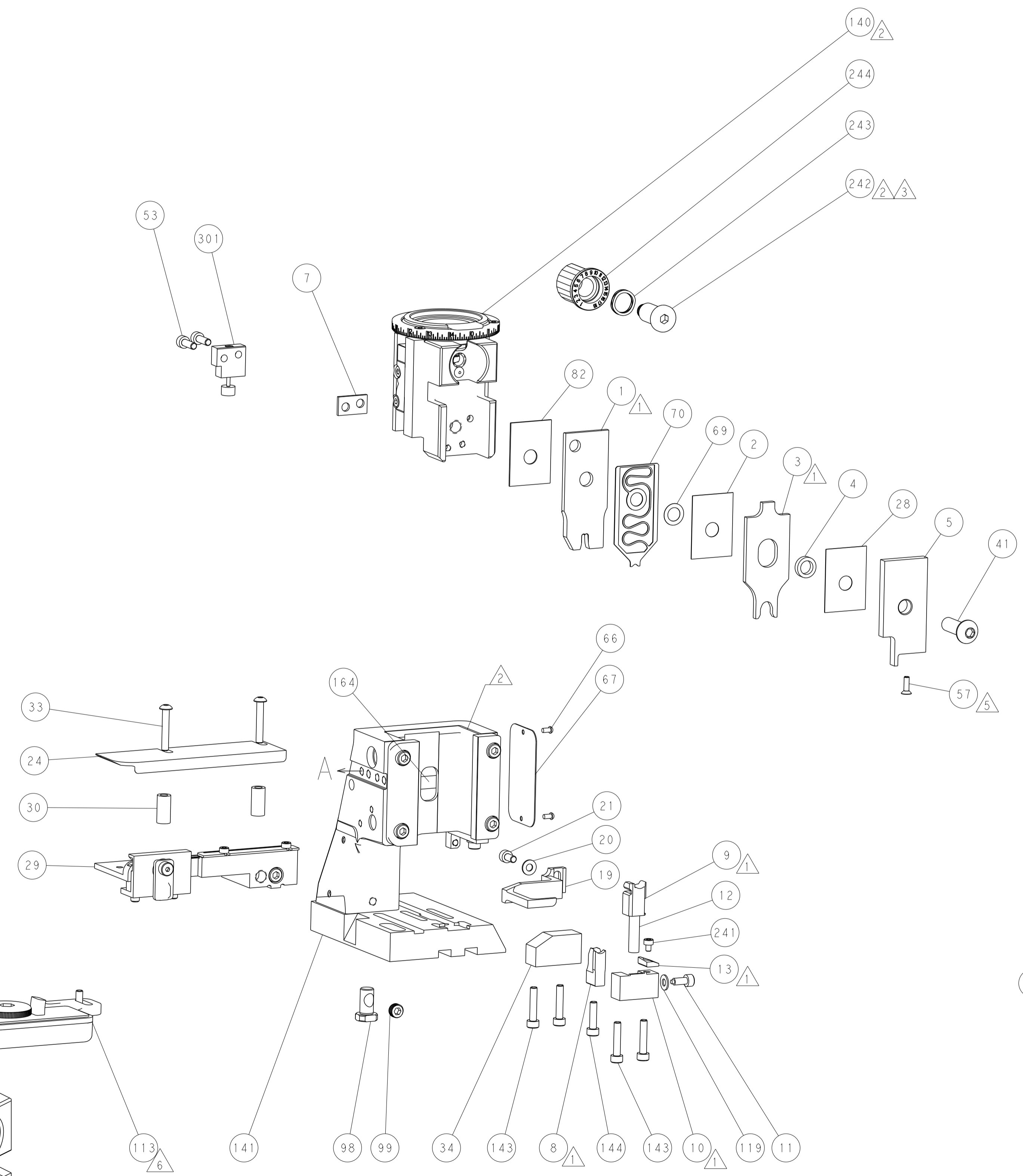

CAM POSITIONS

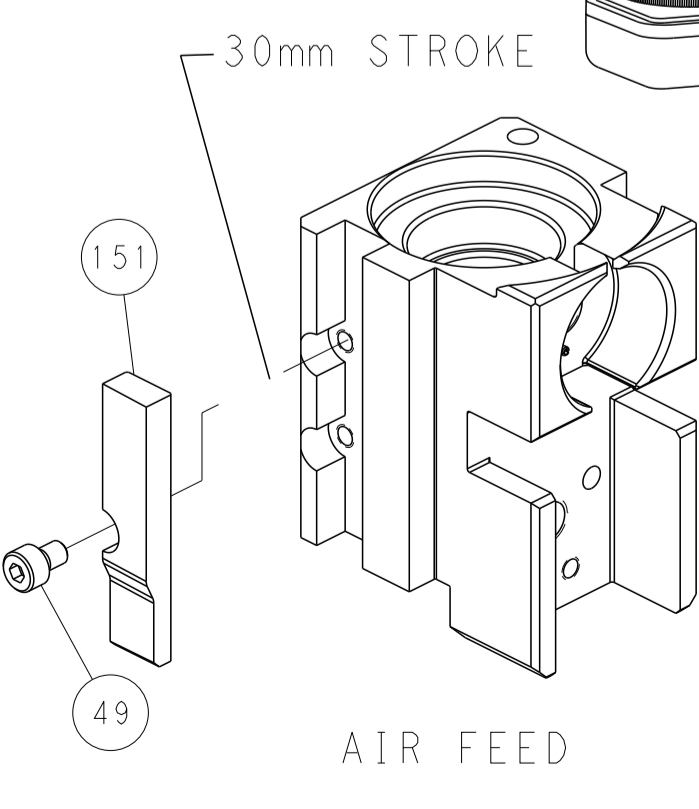
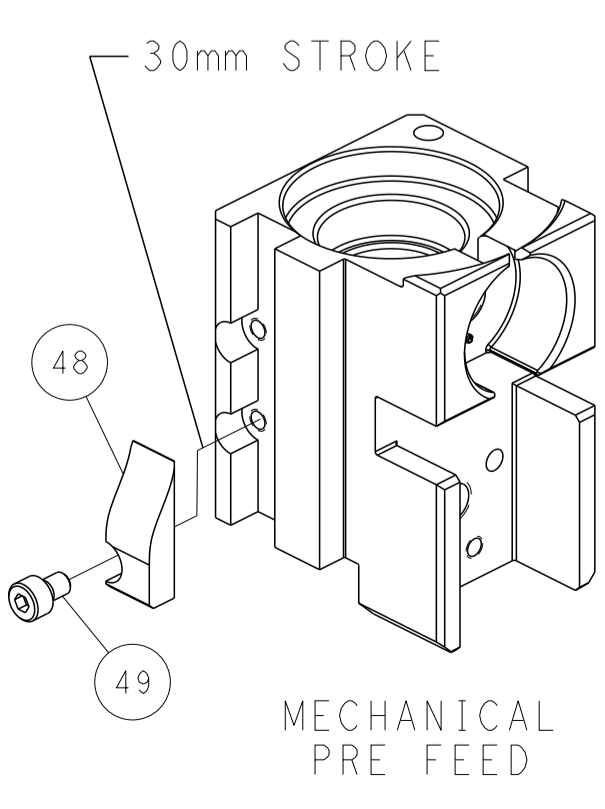
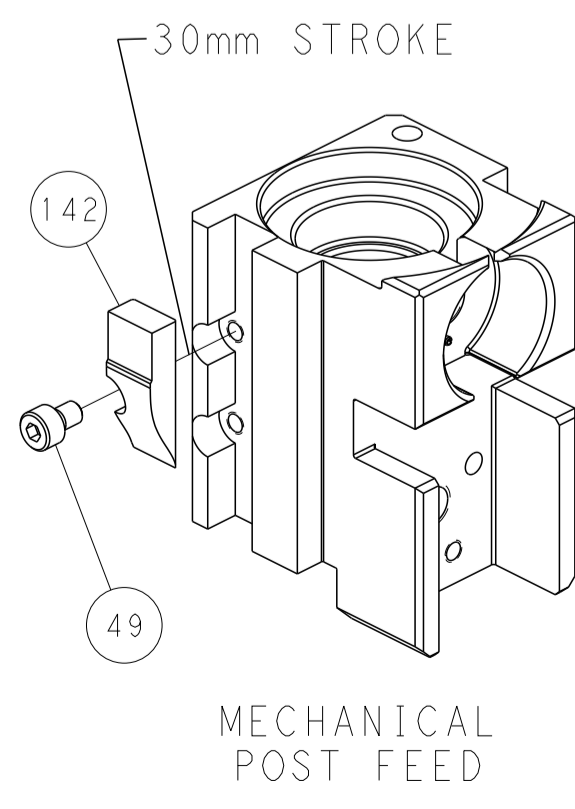

PACIFIC VERSION
 Shown on sheets 3 of 4 & 4 of 4
 (Atlantic version shown on sheets 1 of 4 & 2 of 4)

DIMENSIONS:		TOLERANCES UNLESS OTHERWISE SPECIFIED:		DWG L. ZHANG 16AUG2011		CHK L. ZHANG 16AUG2011		NAME	
mm	0 PLC ±	1 PLC ±	2 PLC ±	3 PLC ±	4 PLC ±	APVD S. XI 16AUG2011	PRODUCT SPEC	Ocean Side Feed Applicator	
MATERIAL		FINISH		WEIGHT		SIZE CAGE CODE DRAWING NO		RESTRICTED TO	
						A1 00779 C=2151466			
Customer Accessible Production Drawing				SCALE 1:2		SHEET 4 OF 4		REV M	