

DO NOT SCALE FROM THIS PRINT

NOTES:

1. **SMALL FORM-FACTOR PLUGGABLE CABLE ASSEMBLY (MATES WITH MECT AND SFPC SERIES).**
2. $\text{\textcircled{C}}$ REPRESENTS A CRITICAL DIMENSION.
3. PARTS TO BE PROCESSED PER SAMTEC ACCEPTABILITY REQUIREMENTS: CO-XX-ML-2000-M "CABLE ASSEMBLY WORKMANSHIP STANDARDS".
4. ALL ASSEMBLIES TO BE 100% ELECTRICALLY TESTED.
5. ALL ASSEMBLIES TO BE 100% HI-POT TESTED AT 300V.
6. ITEM 9 TO BE CENTERED ON ITEM 3 ON BOTH ENDS OF THE CABLE AS SHOWN. ITEM 9 TO CONTAIN: LINE 1 - PART NUMBER "SFPE-010-XXXX-XX-XX", LINE 2 - SHOP ORDER NUMBER "XXXXXX", AND LINE 3 - DATE CODE "XXXXX". NUMERIC REVISION PRODUCT WILL HAVE ADDITIONAL LABEL INDICATING "RELEASE FOR LIMITED PRODUCTION".
7. FOR PROCESSING INFORMATION ON SUB ASSEMBLIES, REFERENCE SUB-SFPE-010-XX-XX-XX TRAVELER.XLS.
8. FOR SUB-ASSEMBLY AND FINISHED GOOD PACKAGING REQUIREMENTS, REFERENCE PACKAGING STANDARD CO-HD-WI-3033-M.
9. PANEL PCB-102388-SFPE-010 YIELDS (10) PCB-102388-SFPE-010 BOARDS.
10. CABLE ASSEMBLIES GREATER THAN 3000MM WILL NOT BE SUPPORTED BY SI TEST REPORTS.

ESD SENSITIVE

THIS PRODUCT MANUFACTURED WITH LEAD-FREE PROCESSING

DESIGNED & DIMENSIONED IN MILLIMETERS [INCHES]

SFPE-010-XXXX-XX-XX

ASSEMBLY LENGTH (MM)
0305-9999 (SEE NOTE 10)
-1000
-2000
-3000
(STOCKED LENGTHS)

WIRE GAUGE
-32: 32AWG 100 OHM

EQUALIZATION
-NE: NON EQUALIZED
* -P1: PASSIVE EQUALIZATION
* -A1: ACTIVE EQUALIZATION

*(NOT TOOLED)

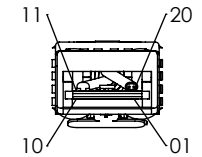
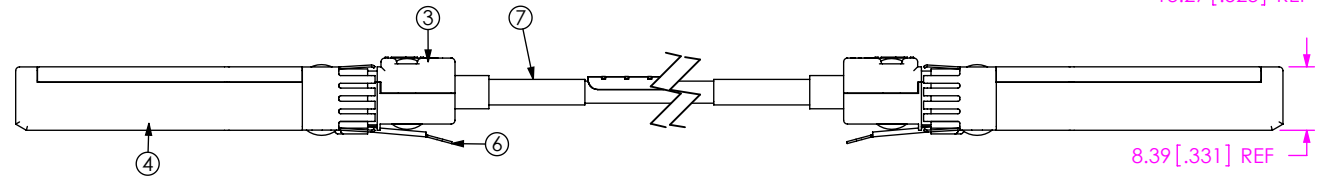
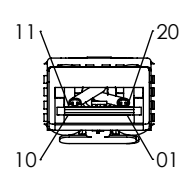
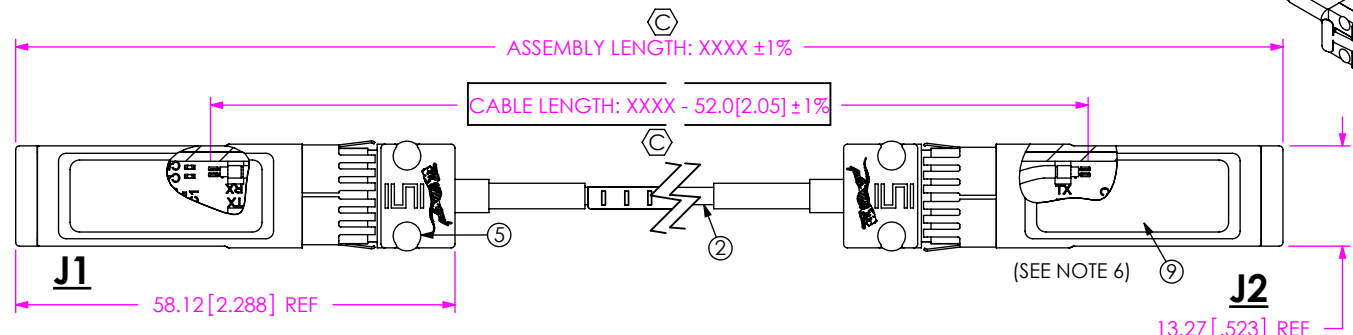
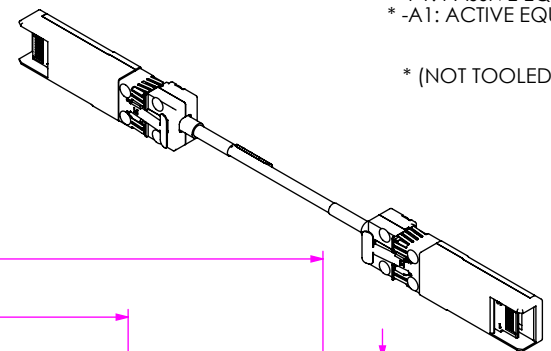

SFPE-010-XXXX-NE-32 SHOWN

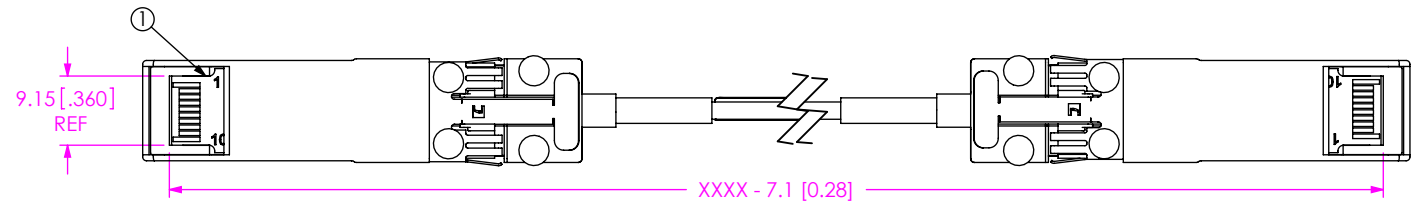

SFPE-010-XXXX-NE-32 BOM

ITEM NO.	PART NUMBER	DESCRIPTION	QUANTITY	MATERIAL
1	SUB-SFPE-010-XX-XX-XX-XXXX	SUB ASSEMBLY	2	SUB ASSEMBLY
2	HSIO-32100-09	TWNA X CABLE	1	SUB ASSEMBLY
3	SFPE-H-01	HOUSING, TOP	2	ZAMAK 3
4	SFPE-H-02	HOUSING, BOTTOM	2	SUB ASSEMBLY
5	RVT-01.5-09.5-001	FASTENER - RIVET	8	LOW CARBON STEEL
6	LTC-26	LATCH	2	STAINLESS STEEL
7	HST-0.187-02-BLK	HEAT SHRINK	4	POLYOLEFIN
8	CUT-0.250	COPPER TAPE	2	COPPER TAPE
9	HDRL-01	LABEL	2	SELF LAMINATING VINYL
10	LABEL-ET	LABEL	1	VINYL

TOLERANCES DO NOT APPLY TO REFERENCE DIMENSIONS.
UNLESS OTHERWISE SPECIFIED, DIMENSIONS ARE IN MILLIMETERS.
TOLERANCES ARE:
DECIMALS ANGLES
X.X: ±0.3 [.01] 2°
X.XX: ±0.13 [.005]
X.XXX: ±0.051 [.0020]

PROPRIETARY NOTE
THIS DOCUMENT CONTAINS CONFIDENTIAL AND PROPRIETARY INFORMATION AND ALL DESIGN, MANUFACTURING, REPRODUCTION, USE, PATENT RIGHTS AND SALES RIGHTS ARE EXPRESSLY RESERVED BY SAMTEC, INC. THIS DOCUMENT SHALL NOT BE DISCLOSED, IN WHOLE OR PART, TO ANY UNAUTHORIZED PERSON OR ENTITY NOR REPRODUCED, TRANSFERRED OR INCORPORATED IN ANY OTHER PROJECT IN ANY MANNER WITHOUT THE EXPRESS WRITTEN CONSENT OF SAMTEC, INC.



520 PARK EAST BLVD, NEW ALBANY, IN 47150
PHONE: 812-944-6733 FAX: 812-948-5047
e-Mail: info@SAMTEC.com code 55322

DO NOT SCALE DRAWING SHEET SCALE: 1:1

DESCRIPTION:
SFP+ EYE SPEED CABLE ASSEMBLY
DWG. NO.
SFPE-010-XXXX-XX-XX
BY: ANDREW C 08/31/2009 SHEET 1 OF 4

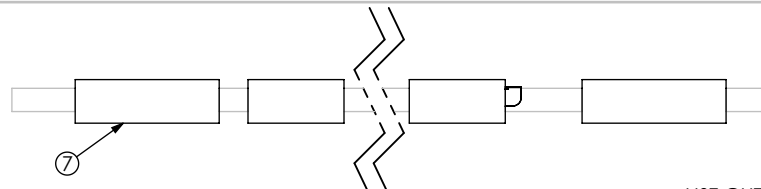

SLIDE HEAT SHRINK OVER CABLE
BEFORE STRIPPING INSULATION

HST CUT LENGTHS: (NOT TO SCALE)
INNER: 19.0 [0.75]
OUTER: 31.8 [1.25]

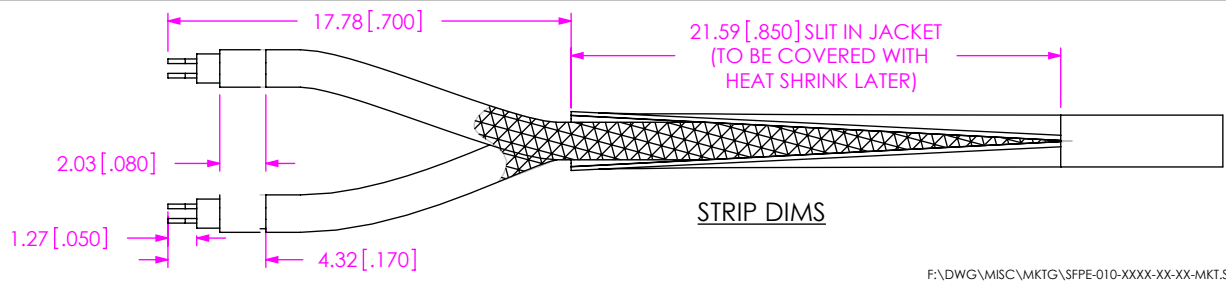
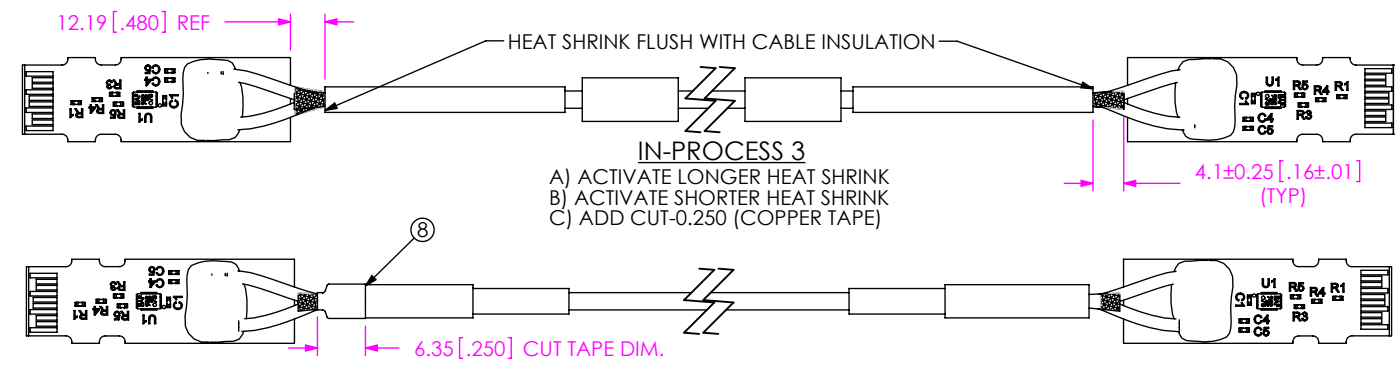
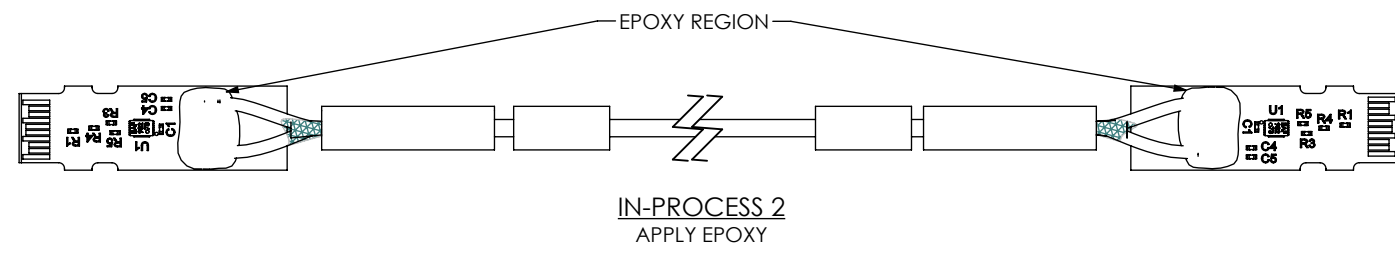
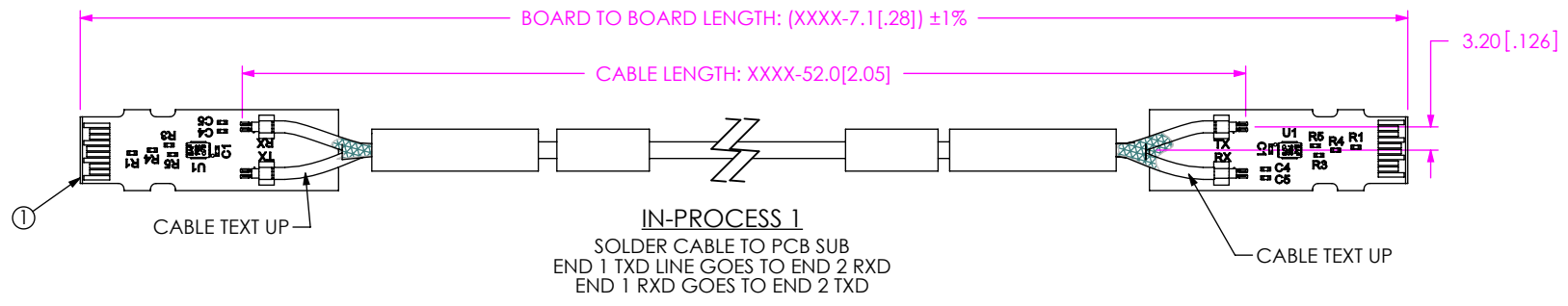

PROPRIETARY NOTE
THIS DOCUMENT CONTAINS CONFIDENTIAL AND PROPRIETARY INFORMATION AND ALL DESIGN, MANUFACTURING, REPRODUCTION, USE, PATENT RIGHTS AND SALES RIGHTS ARE EXPRESSLY RESERVED BY SAMTEC, INC. THIS DOCUMENT SHALL NOT BE DISCLOSED, IN WHOLE OR PART, TO ANY UNAUTHORIZED PERSON OR ENTITY NOR REPRODUCED, TRANSFERRED OR INCORPORATED IN ANY OTHER PROJECT IN ANY MANNER WITHOUT THE EXPRESS WRITTEN CONSENT OF SAMTEC, INC.

DO NOT SCALE DRAWING

SHEET SCALE: 1:1

samtec
520 PARK EAST BLVD., NEW ALBANY, IN 47150
PHONE: 812-944-6733 FAX: 812-948-5047
e-Mail info@SAMTEC.com code 55322

DESCRIPTION:
SFP+ EYE SPEED CABLE ASSEMBLY

DWG. NO.
SFPE-010-XXXX-XX-XX

BY: ANDREW C 08/31/2009 SHEET 2 OF 4

PLACE PCB SUB-ASSY INTO BOTTOM HOUSING
TAKE CARE TO ALIGN PCB NOTCHES WITH GUIDES IN HOUSING



TIP OF TOP HOUSING LOCKS INTO BOTTOM HOUSING

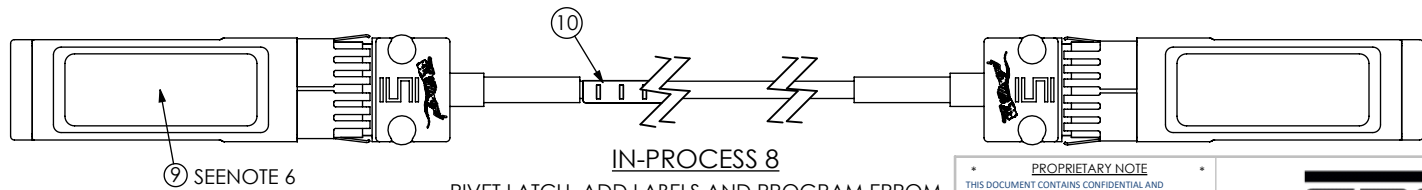
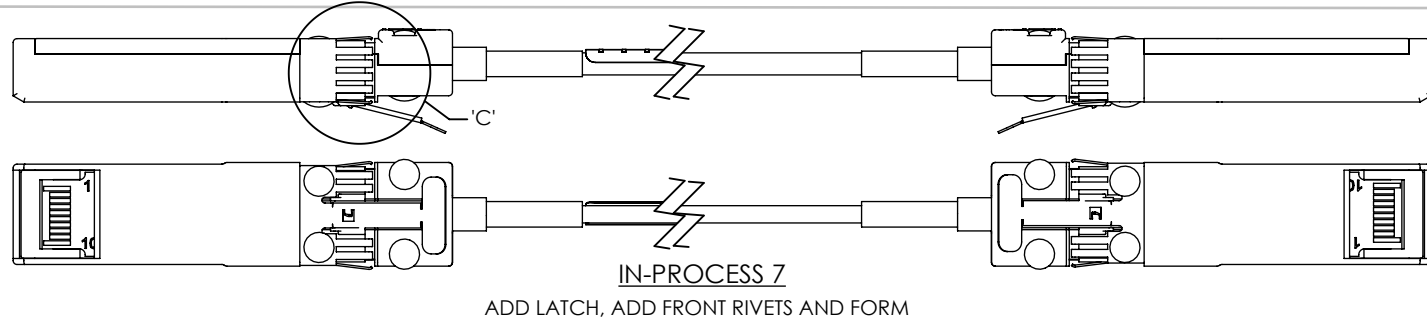
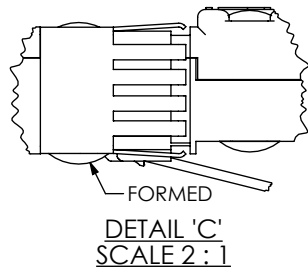
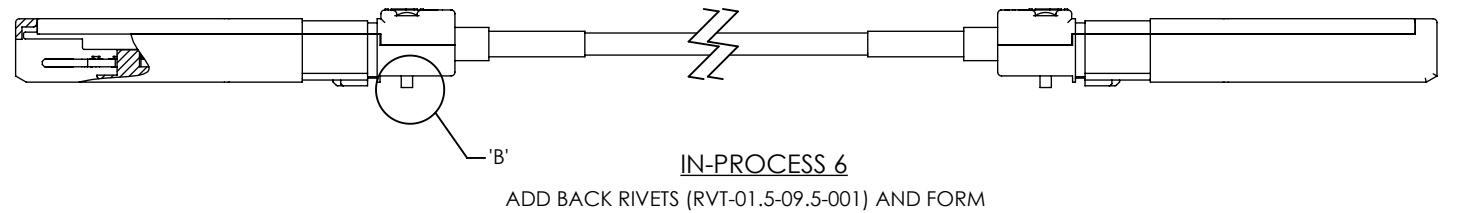
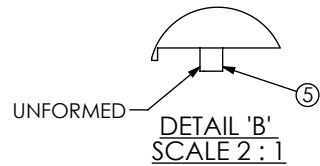
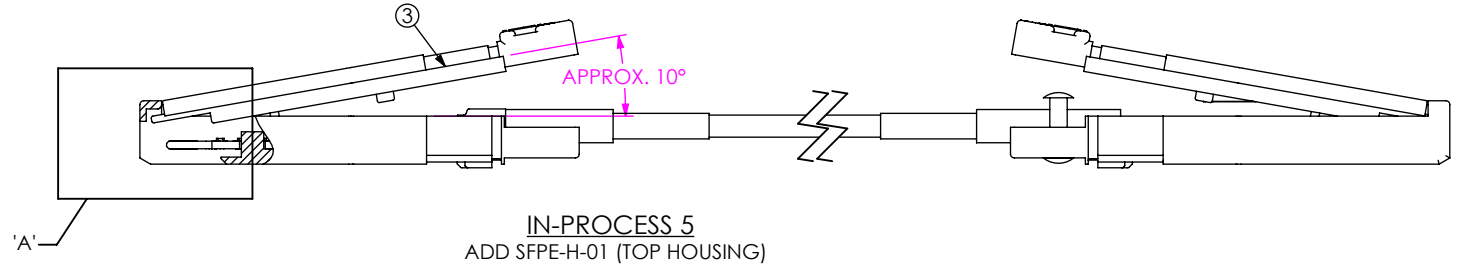
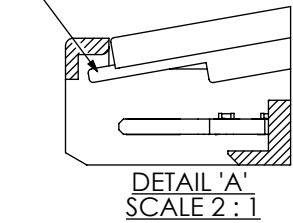

PROPRIETARY NOTE
THIS DOCUMENT CONTAINS CONFIDENTIAL AND PROPRIETARY INFORMATION AND ALL DESIGN, MANUFACTURING, REPRODUCTION, USE, PATENT RIGHTS AND SALES RIGHTS ARE EXPRESSLY RESERVED BY SAMTEC, INC. THIS DOCUMENT SHALL NOT BE DISCLOSED, IN WHOLE OR PART, TO ANY UNAUTHORIZED PERSON OR ENTITY NOR REPRODUCED, TRANSFERRED OR INCORPORATED IN ANY OTHER PROJECT IN ANY MANNER WITHOUT THE EXPRESS WRITTEN CONSENT OF SAMTEC, INC.



520 PARK EAST BLVD, NEW ALBANY, IN 47150
PHONE: 812-944-6733 FAX: 812-948-5047
e-Mail info@SAMTEC.com code 55322

DO NOT SCALE DRAWING

SHEET SCALE: 1:1

DESCRIPTION:
SFP+ EYE SPEED CABLE ASSEMBLY

DWG. NO.
SFPE-010-XXXX-XX-XX

BY: ANDREW C 08/31/2009 SHEET 3 OF 4

TABLE 1 - PINOUT			
J1	NAME	NAME	J1
1	VEET	VEET	20
2	TX_FAULT	TD-	19
3	TX_DISABLE	TD+	18
4	SDA	VEET	17
5	SCL	VCCT	16
6	MOD_ABS	VCCR	15
7	RSO	VEER	14
8	RX_LOS	RD+	13
9	RS1	RD-	12
10	VEER	VEER	11
TD-/TD+ TRANSMITS TO RD-/RD+			
PINS 1, 2, 6, 8, 10, 11, 14, 17, 20 ARE GROUND			
PINS 7, 9 ARE NO CONNECTS			

PROPRIETARY NOTE

THIS DOCUMENT CONTAINS CONFIDENTIAL AND PROPRIETARY INFORMATION AND ALL DESIGN, MANUFACTURING, REPRODUCTION, USE, PATENT RIGHTS AND SALES RIGHTS ARE EXPRESSLY RESERVED BY SAMTEC, INC. THIS DOCUMENT SHALL NOT BE DISCLOSED, IN WHOLE OR PART, TO ANY UNAUTHORIZED PERSON OR ENTITY NOR REPRODUCED, TRANSFERRED OR INCORPORATED IN ANY OTHER PROJECT IN ANY MANNER WITHOUT THE EXPRESS WRITTEN CONSENT OF SAMTEC, INC.



520 PARK EAST BLVD. NEW ALBANY, IN 47150
 PHONE: 812-944-6733 FAX: 812-948-5047
 e-Mail info@SAMTEC.com code 55322

SHEET SCALE: 1:1

DESCRIPTION: SFP+ EYE SPEED CABLE ASSEMBLY

DWG. NO. SFPE-010-XXXX-XX-XX

BY: ANDREW C 08/31/2009 SHEET 4 OF 4