



SIM7600 Series Hardware Design

LTE Module

SIMCom Wireless Solutions Limited

Building 3, No.289, LinHong Road
Changning District, Shanghai P.R.China

Tel: 86-21-31575100

support@simcom.com

www.simcom.com

Document Title:	SIM7600 Series Hardware Design
Version:	V1.09
Date:	2022-11-03
Status:	Released

GENERAL NOTES

SIMCOM OFFERS THIS INFORMATION AS A SERVICE TO ITS CUSTOMERS, TO SUPPORT APPLICATION AND ENGINEERING EFFORTS THAT USE THE PRODUCTS DESIGNED BY SIMCOM. THE INFORMATION PROVIDED IS BASED UPON REQUIREMENTS SPECIFICALLY PROVIDED TO SIMCOM BY THE CUSTOMERS. SIMCOM HAS NOT UNDERTAKEN ANY INDEPENDENT SEARCH FOR ADDITIONAL RELEVANT INFORMATION, INCLUDING ANY INFORMATION THAT MAY BE IN THE CUSTOMER'S POSSESSION. FURTHERMORE, SYSTEM VALIDATION OF THIS PRODUCT DESIGNED BY SIMCOM WITHIN A LARGER ELECTRONIC SYSTEM REMAINS THE RESPONSIBILITY OF THE CUSTOMER OR THE CUSTOMER'S SYSTEM INTEGRATOR. ALL SPECIFICATIONS SUPPLIED HEREIN ARE SUBJECT TO CHANGE.

COPYRIGHT

THIS DOCUMENT CONTAINS PROPRIETARY TECHNICAL INFORMATION WHICH IS THE PROPERTY OF SIMCOM WIRELESS SOLUTIONS LIMITED COPYING, TO OTHERS AND USING THIS DOCUMENT, ARE FORBIDDEN WITHOUT EXPRESS AUTHORITY BY SIMCOM. OFFENDERS ARE LIABLE TO THE PAYMENT OF INDEMNIFICATIONS. ALL RIGHTS RESERVED BY SIMCOM IN THE PROPRIETARY TECHNICAL INFORMATION , INCLUDING BUT NOT LIMITED TO REGISTRATION GRANTING OF A PATENT , A UTILITY MODEL OR DESIGN. ALL SPECIFICATION SUPPLIED HEREIN ARE SUBJECT TO CHANGE WITHOUT NOTICE AT ANY TIME.

SIMCom Wireless Solutions Limited

Building 3, No.289, LinHong Road, Changning District, Shanghai P.R.China

Tel: +86 21 31575100

Email: simcom@simcom.com

For more information, please visit:

<https://www.simcom.com/download/list-863-en.html>

For technical support, or to report documentation errors, please visit:

<https://www.simcom.com/ask/> or email to: support@simcom.com

Copyright © 2022 SIMCom Wireless Solutions Limited All Rights Reserved.

Version History

Date	Version	Description of change	Author
2017-10-11	1.00	Original	Ma Hong Gang Gao Fan
2017-11-23	1.01	Modify Table2, Table15, Table 8, Table16, Table21, Table 26 Modify Figure 4, Figure 10 Modify 3.13.3 LDO output voltage 2.85V by default. Rename VDD_EXT to VDD_AUX	Gao Fan Yuan Shi Jie
2018-4-11	V1.02	Modify table 1,2,5,15,22,34 Modify figure 4,36,37 Modify the document name	Yuan Shi Jie Gao Fan
2019-4-30	V1.03	Update table 8; Update table 10; Update table 30;	Ma Hong Gang
2019-11-22	V1.04	Correct the figure 11;	Ma Hong gang
2019-12-03	V1.05	Add recommend SMT stencil;	Ma Hong gang
2020-3-19	V1.06	Update document templet Update some parameters	Ma Hong gang Gan Wen Ke
2020-5-06	V1.07	Update figure 2;	Ma Hong gang
2021-8-13	V1.08	Update reset timing diagram and reset timing parameters	Liu Wang Rong
2022-11-03	V1.09	Update uart rate.	Liu Wang Rong

Confidential

Contents

Table Index.....	6
Figure Index.....	7
1 Introduction.....	8
1.1 Product Outline.....	8
1.2 Hardware Interface Overview.....	9
1.3 Hardware Block Diagram.....	9
1.4 Functional Overview.....	10
2 Package Information.....	13
2.1 Pin Assignment Overview.....	13
2.2 Pin Description.....	15
2.3 Mechanical Information.....	19
2.4 Footprint Recommendation.....	20
3 Interface Application.....	21
3.1 Power Supply.....	21
3.1.1 Power Supply Design Guide.....	22
3.1.2 Recommended Power Supply Circuit.....	23
3.1.3 Voltage Monitor.....	24
3.2 Power on/Power off/Reset Function.....	24
3.2.1 Power on.....	24
3.2.2 Power off.....	26
3.2.3 Reset Function.....	27
3.3 UART Interface.....	29
3.3.1 UART Design Guide.....	29
3.3.2 RI and DTR Behavior.....	31
3.4 USB Interface.....	32
3.4.1 USB diagram.....	32
3.4.2 USB_BOOT.....	32
3.4.3 USB_ID.....	33
3.5 USIM Interface.....	34
3.5.1 USIM Application Guide.....	35
3.5.2 USIM Design Notice.....	36
3.5.3 Recommended USIM Card Holder.....	36
3.6 PCM Interface.....	37
3.6.1 PCM timing.....	38
3.6.2 PCM Application Guide.....	40
3.7 SD Interface.....	40
3.8 I2C Interface.....	41
3.9 SDIO Interface.....	42
3.10 SPI Interface.....	42
3.11 Network Status.....	42
3.12 Flight Mode Control.....	43
3.13 HSIC Interface.....	44
3.14 GPIO Interface.....	44
3.15 Other Interface.....	45
3.15.1 Sink Current Source.....	45
3.15.2 ADC.....	46
3.15.3 LDO.....	46
4 RF Specifications.....	48
4.1 GSM/UMTS/LTE RF Specifications.....	48
4.2 GSM /UMTS/LTE Antenna Design Guide.....	51

4.3	GNSS.....	52
4.3.1	GNSS Technical specification.....	52
4.3.2	GNSS Application Guide.....	53
5	Electrical Specifications.....	55
5.1	Absolute maximum ratings.....	55
5.2	Operating conditions.....	55
5.3	Operating Mode.....	56
5.3.1	Operating Mode Definition.....	56
5.3.2	Sleep mode.....	57
5.3.3	Minimum functionality mode and Flight mode.....	57
5.4	Current Consumption.....	58
5.5	ESD Notes.....	60
6	SMT Production Guide.....	61
6.1	Top and Bottom View of Module.....	61
6.2	Label Information.....	61
6.3	Typical SMT Reflow Profile.....	62
6.4	Moisture Sensitivity Level (MSL).....	62
6.5	Recommend dimensions of SMT stencil.....	63
6.6	Stencil Foil Design Recommendation.....	64
7	Packaging.....	65
8	Appendix.....	67
8.1	Reference Design.....	67
8.2	Coding Schemes and Maximum Net Data Rates over Air Interface.....	68
8.3	Related Documents.....	70
8.4	Terms and Abbreviations.....	72
8.5	Safety Caution.....	74

Table Index

Table 1: Module frequency bands(* Stand for SIM7600).....	8
Table 2: General features.....	10
Table 3: Pin definition.....	14
Table 4: IO parameters definition.....	15
Table 5: Pin description.....	15
Table 6: VBAT pins electronic characteristic.....	21
Table 7: Recommended TVS list.....	23
Table 8: Power on timing and electronic characteristic.....	25
Table 9: Power off timing and electronic characteristic.....	26
Table 10: Reset timing parameters.....	28
Table 11: USB_BOOT description.....	32
Table 12: USB_ID description.....	34
Table 13: USIM electronic characteristic in 1.8V mode (USIM_VDD=1.8V).....	34
Table 14: USIM electronic characteristic 3.0V mode (USIM_VDD=2.95V).....	35
Table 15: Amphenol USIM socket pin description.....	37
Table 16: PCM format.....	37
Table 17: PCM timing parameters (2G/3G mode).....	39
Table 18: PCM timing parameters (4G mode).....	39
Table 19: MMC/SD electronic characteristic (SD_DATA0-SD_DATA3, SD_CLK and SD_CMD) *.....	40
Table 20: NETLIGHT pin status.....	43
Table 21: FLIGHTMODE pin status.....	43
Table 22: Key differences between HSIC and USB.....	44
Table 23: WIFI/BT Version GPIO.....	45
Table 24: Standard version GPIO.....	45
Table 25: Sink current electronic characteristic.....	45
Table 26: ADC1 and ADC2 electronic characteristics.....	46
Table 27: Electronic characteristic.....	47
Table 28: Conducted transmission power.....	48
Table 29: Operating frequencies.....	49
Table 30: E-UTRA operating bands.....	49
Table 31: Conducted receive sensitivity.....	50
Table 32: Reference sensitivity (QPSK).....	50
Table 33: Trace loss.....	51
Table 34: Recommended TVS.....	52
Table 35: Recommended Passive Antenna Characteristics.....	53
Table 36: Recommended LNA and SAW Filter.....	54
Table 37: Absolute maximum ratings.....	55
Table 38: Recommended operating ratings.....	55
Table 39: 1.8V Digital I/O characteristics*.....	55
Table 40: Operating temperature.....	56
Table 41: Operating mode Definition.....	56
Table 42: Current consumption on VBAT Pins (VBAT=3.8V).....	58
Table 43: The ESD performance measurement table (Temperature: 25°C, Humidity: 45%).....	60
Table 44: The description of label information.....	62
Table 45: Moisture Sensitivity Level and Floor Life.....	63
Table 46: Tray size.....	66
Table 47: Small Carton size.....	66
Table 48: Big Carton size.....	66
Table 49: Coding Schemes and Maximum Net Data Rates over Air Interface.....	68
Table 50: Related Documents.....	70
Table 51: Terms and Abbreviations.....	72
Table 52: Safety Caution.....	74

Figure Index

Figure 1: Module block diagram.....	10
Figure 2: Pin assignment overview.....	13
Figure 3: Dimensions (Unit: mm).....	19
Figure 4: Footprint recommendation (Unit: mm).....	20
Figure 5: VBAT voltage drop during burst emission (GSM/GPRS).....	21
Figure 6: Power supply application circuit.....	22
Figure 7: Linear regulator reference circuit.....	23
Figure 8: Switching mode power supply reference circuit.....	23
Figure 9: Reference power on/off circuit.....	24
Figure 10: Power on timing sequence.....	25
Figure 11: Power off timing sequence.....	26
Figure 12: Reference reset circuit.....	27
Figure 13: Reset timing sequence.....	28
Figure 14: UART full modem.....	29
Figure 15: UART null modem.....	29
Figure 16: Reference circuit of level shift.....	30
Figure 17: Level matching circuit with triode.....	30
Figure 18: RI behaviour (SMS and URC report)	31
Figure 19: RI behaviour (voice call)	31
Figure 20: USB reference circuit.....	32
Figure 21: USB_BOOT circuit.....	33
Figure 22: Force download port.....	33
Figure 23: USB_OTG diagram.....	34
Figure 24: USIM interface reference circuit.....	35
Figure 25: USIM interface reference circuit with USIM_DET.....	36
Figure 26: Amphenol SIM card socket.....	37
Figure 27: PCM_SYNC timing.....	38
Figure 28: EXT codec to module timing.....	38
Figure 29: Module to EXT codec timing.....	38
Figure 30: Audio codec reference circuit.....	40
Figure 31: SD reference circuit.....	41
Figure 32: I2C reference circuit.....	41
Figure 33: NETLIGHT reference circuit.....	42
Figure 34: Flight mode switch reference circuit.....	43
Figure 35: ISINK reference circuit.....	46
Figure 36: Antenna matching circuit (MAIN_ANT).....	51
Figure 37: Antenna matching circuit (AUX_ANT).....	52
Figure 38: Active antenna circuit.....	53
Figure 39: Passive antenna circuit (Default).....	54
Figure 40: Top and bottom view of module.....	61
Figure 41: Label information.....	61
Figure 42: The ramp-soak-spike reflow profile of module.....	62
Figure 43: Recommend SMT stencil.....	63
Figure 44: packaging diagram.....	65
Figure 45: Tray drawing.....	65
Figure 46: Small carton drawing.....	66
Figure 47: Big carton drawing.....	66
Figure 48: Reference design.....	67

1 Introduction

This document describes the electronic specifications, RF specifications, interfaces, mechanical characteristics and testing results of the SIMCom module. With the help of this document and other software application notes/user guides, users can understand and use module to design and develop applications quickly.

1.1 Product Outline

Aimed at the global market, the module support GSM, WCDMA, LTE-TDD and LTE-FDD. Users can choose the module according to the wireless network configuration. The supported radio frequency bands are described in the following table.

Table 1: Module frequency bands(* Stand for SIM7600)

Standard	Frequency	*A	*A-H	*V-H	*E	*E-H	*JC-H	*SA	*SA-H	*E-L1C	*E-H1C
GSM	850MHz							√	√		
	900MHz				√	√		√	√	√	√
	1800M Hz				√	√		√	√	√	√
	1900M Hz							√	√		
WCDMA	B1				√	√		√	√	√	√
	B2	√	√					√	√		
	B5	√	√		√	√		√	√		√
	B8				√	√		√	√	√	√
LTE	FDD B1				√	√	√	√	√	√	√
	FDD B2	√	√	√				√	√		
	FDD B3				√	√	√	√	√	√	√
	FDD B4	√	√	√				√	√		
	FDD B5			√	√	√		√	√		√
	FDD B7				√	√		√	√	√	√
	FDD B8				√	√	√	√	√	√	√
	FDD B12	√	√								
	FDD B13			√							
	FDD B18						√				
	FDD B19						√				
	FDD B20				√	√				√	√
FDD B26						√					

FDD B28							√	√		
TDD B38			√	√						√
TDD B40			√	√			√	√		√
TDD B41			√	√						√
Category	CAT1	CAT4	CAT4	CAT1	CAT4	CAT4	CAT1	CAT4	CAT1	CAT4

With a small physical dimension of 30*30*2.9 mm and with the functions integrated, the module can meet almost any space requirement in users' applications, such as smart phone, PDA, industrial handheld, machine-to-machine and vehicle application, etc.

1.2 Hardware Interface Overview

The interfaces are described in detail in the next chapters include:

- Power Supply
- USB Interface
- UART Interface
- MMC/SD Interface
- SDIO Interface
- USIM Interface
- GPIO
- ADC
- LDO Power Output
- Current Sink Source
- PCM Interface
- SPI Interface
- I2C Interface

1.3 Hardware Block Diagram

The block diagram of the module is shown in the figure below.

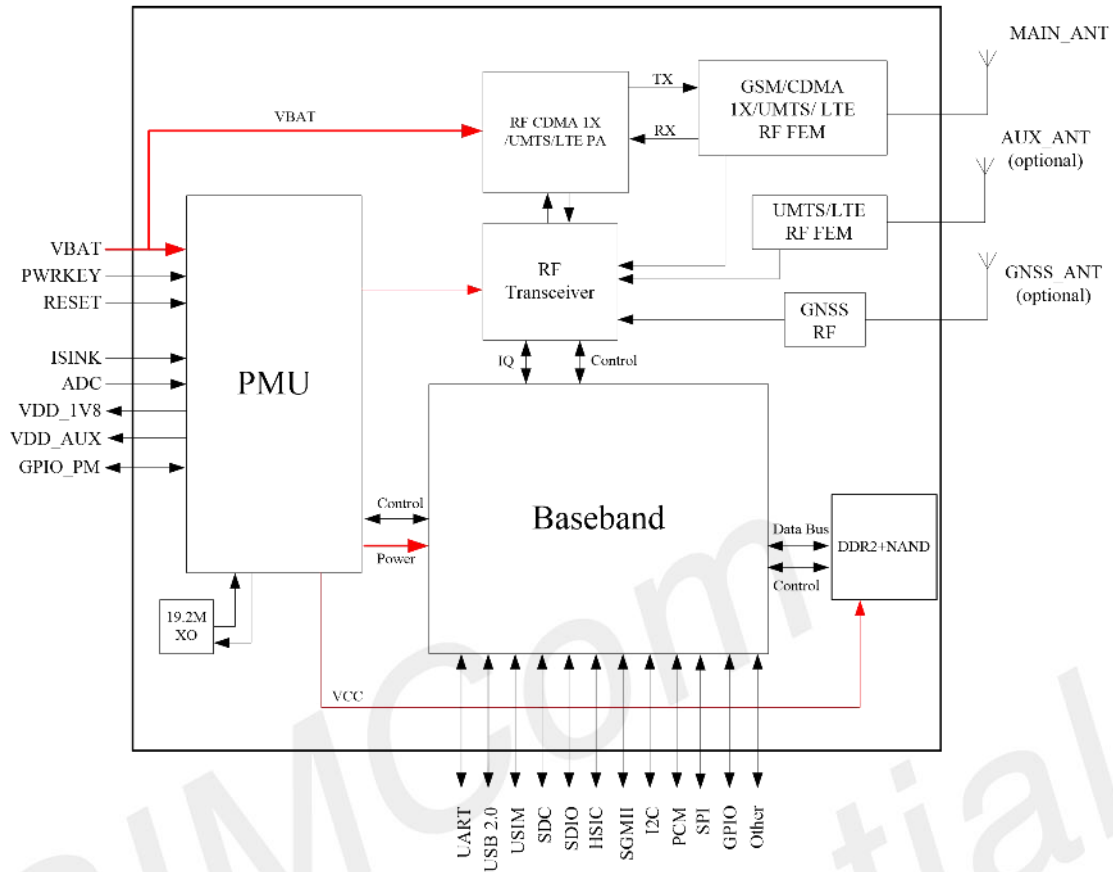

Figure 1: Module block diagram

1.4 Functional Overview

Table 2: General features

Feature	Implementation
Power supply	Single supply voltage 3.4 ~ 4.2V, recommend 3.8V.
Power saving	Current in sleep mode : <5mA
Radio frequency bands	Please refer to the table 1
Transmitting power	GSM/GPRS power class: --GSM850: 4 (2W) --EGSM900: 4 (2W) --DCS1800: 1 (1W) --PCS1900: 1 (1W) EDGE power class: --GSM850: E2 (0.5W) --EGSM900: E2 (0.5W) --DCS1800: E1 (0.4W) --PCS1900: E1 (0.4W)

	<p>UMTS power class: --WCDMA :3 (0.25W) LTE power class: 3 (0.25W)</p>
Data Transmission Throughput	<p>GPRS multi-slot class 12 EDGE multi-slot class 12 UMTS R99 speed: 384 kbps DL/UL HSPA+: 5.76 Mbps(UL), 42 Mbps(DL) HSDPA/HSUPA: 2.2 Mbps(UL), 2.8 Mbps(DL) LTE CAT 1: 10 Mbps(DL) 5 Mbps(UL) LTE-FDD CAT4 : 150 Mbps (DL), 50 Mbps (UL) LTE-TDD CAT4 : 130 Mbps (DL), 35 Mbps (UL)</p>
Antenna	<p>GSM/UMTS/LTE main antenna. UMTS/LTE auxiliary antenna GNSS antenna</p>
GNSS	<p>GNSS engine (GPS, GLONASS and BD) Protocol: NMEA</p>
SMS	<p>MT, MO, CB, Text and PDU mode SMS storage: USIM card or ME(default) Transmission of SMS alternatively over CS or PS.</p>
USIM interface	<p>Support identity card: 1.8V/ 3V</p>
USIM application toolkit	<p>Support SAT class 3, GSM 11.14 Release 98 Support USAT</p>
Phonebook management	<p>Support phonebook types: DC, MC, RC, SM, ME, FD, ON, LD, EN</p>
Audio feature	<p>Support PCM interface Only support PCM master mode and short frame sync, 16-bit linear data formats</p>
UART interface	<p>A full modem serial port by default Baud rate: 300bps to 3.6Mbps(default:115200bps) Baud rate: 9600,19200,38400,57600,115200bps Can be used as the AT commands or data stream channel Support RTS/CTS hardware handshake Multiplex ability according to GSM 07.10 Multiplexer Protocol</p>
MMC/SD	<p>Support MMC and SD cards with 2.85 V on SD port</p>
SDIO	<p>Support SDIO with 1.8 V only on SDIO port</p>
USB	<p>USB 2.0 high speed interface</p>
Firmware upgrade	<p>Firmware upgrade over USB interface or FOTA</p>
Physical characteristics	<p>Size:30*30*2.9m Weight:5.7 g</p>
Temperature range	<p>Normal operation temperature: -30°C to +80°C Extended operation temperature: -40°C to +85°C* Storage temperature -45°C to +90°C</p>

NOTE

Module is able to make and receive voice calls, data calls, SMS and make GPRS/UMTS/HSPA+/LTE traffic in $-40^{\circ}\text{C} \sim +85^{\circ}\text{C}$. The performance will be reduced slightly from the 3GPP specifications if the temperature is outside the normal operating temperature range and still within the extreme operating temperature range.

SIMCom
Confidential

2 Package Information

2.1 Pin Assignment Overview

All functions of the module will be provided through 87 pads that will be connected to the customers' platform. The following Figure is a high-level view of the pin assignment of the module.

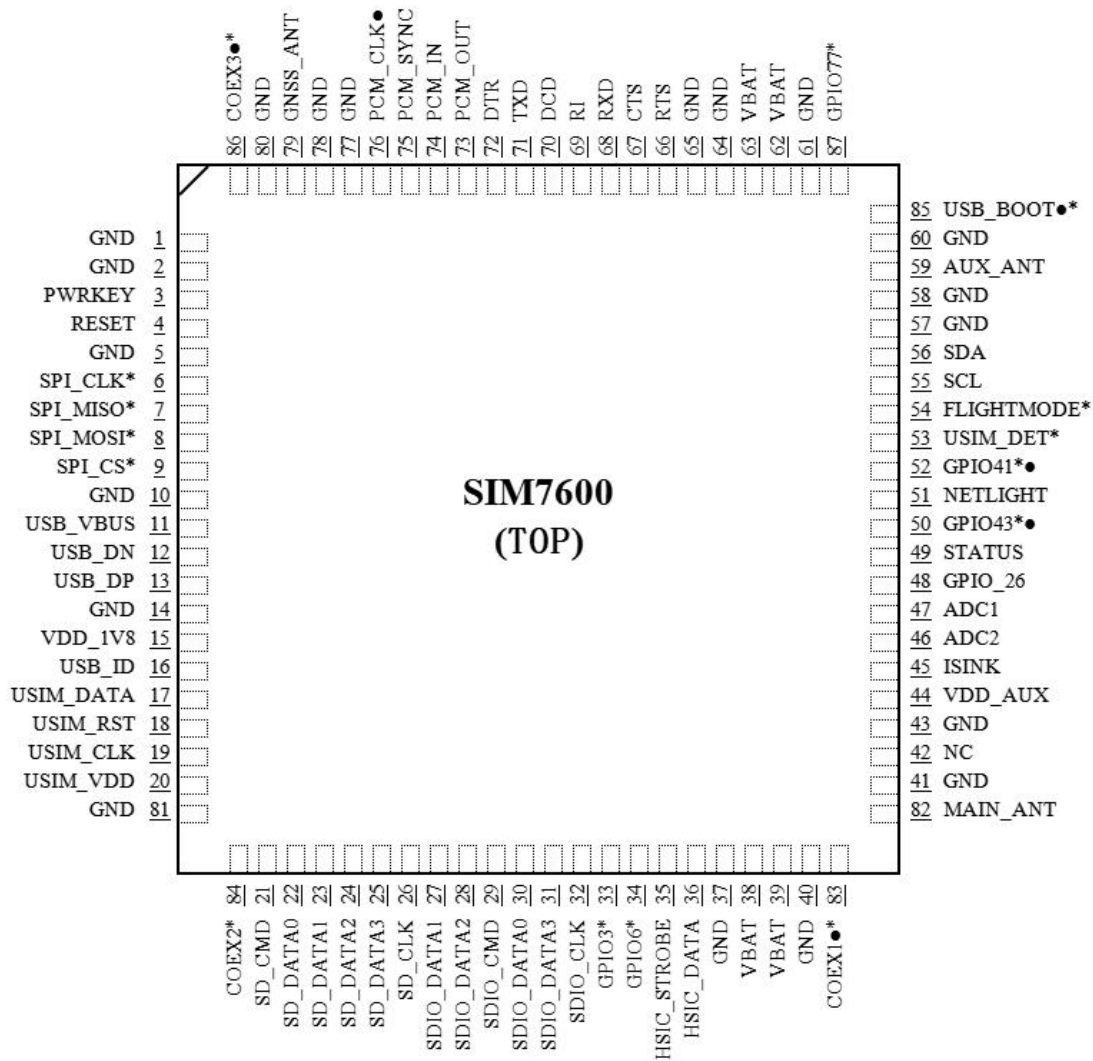

Figure 2: Pin assignment overview

Table 3: Pin definition

Pin No.	Pin name	Pin No.	Pin name
1	GND	2	GND
3	PWRKEY	4	RESET
5	GND	6	SPI_CLK
7	SPI_MISO	8	SPI_MOSI
9	SPI_CS	10	GND
11	USB_VBUS	12	USB_DN
13	USB_DP	14	GND
15	VDD_1V8	16	USB_ID
17	USIM_DATA	18	USIM_RST
19	USIM_CLK	20	USIM_VDD
21	SD_CMD	22	SD_DATA0
23	SD_DATA1	24	SD_DATA2
25	SD_DATA3	26	SD_CLK
27	SDIO_DATA1	28	SDIO_DATA2
29	SDIO_CMD	30	SDIO_DATA0
31	SDIO_DATA3	32	SDIO_CLK
33	GPIO3	34	GPIO6
35	HSIC_STROBE	36	HSIC_DATA
37	GND	38	VBAT
39	VBAT	40	GND
41	GND	42	NC (RESERVED)
43	GND	44	VDD_AUX
45	ISINK	46	ADC2
47	ADC1	48	SD_DET
49	STATUS	50	GPIO43●
51	NETLIGHT	52	GPIO41●
53	USIM_DET	54	FLIGHTMODE
55	SCL	56	SDA
57	GND	58	GND
59	AUX_ANT	60	GND
61	GND	62	VBAT
63	VBAT	64	GND
65	GND	66	RTS
67	CTS	68	RXD
69	RI	70	DCD
71	TXD	72	DTR
73	PCM_OUT	74	PCM_IN

75	PCM_SYNC	76	PCM_CLK●
77	GND	78	GND
79	GNSS_ANT	80	GND
81	GND	82	MAIN_ANT
83	COEX1●	84	COEX2
85	USB_BOOT●	86	COEX3●
87	GPIO77		

NOTE

Before the normal power the marked pins with ● cannot be pulled up, otherwise module will not be powered up normally.

2.2 Pin Description

Table 4: IO parameters definition

Pin type	Description
PI	Power input
PO	Power output
AI	Analog input
AIO	Analog input/output
I/O	Bidirectional input /output
DI	Digital input
DO	Digital output
DOH	Digital output with high level
DOL	Digital output with low level
PU	Pull up
PD	Pull down

Table 5: Pin description

Pin name	Pin No	Default status	Description	Comment
Power supply				
VBAT	38,39, 62,63	PI		Power supply, voltage range: 3.4 ~ 4.2V.
VDD_AUX	44	PO	LDO power output for other external circuits with Max 150mA current output. Its output voltage	If unused, keep it open.

			is 2.85V by default. (The voltage can be configured from 1.7V to 3.05V by AT command) .	
VDD_1V8	15	PO	1.8 output with Max 50mA current output for external circuit, such as level shift circuit.	If unused, keep it open.
GND	1,2,5, 10,14,37,40,4 1,43,57,58,60 ,61,64,65,77, 78,80,81		Ground	
System Control				
PWRKEY	3	DI,PU	System power on/off control input, active low.	The high voltage is 0.8V;
RESET	4	DI, PU	System reset control input, active low.	RESET has been pulled up to 1.8V via 40Kohm resistor internally.
SD interface				
SD_CMD	21	DO	SDIO command	
SD_DATA0	22	I/O		
SD_DATA1	23	I/O	SDIO data	SIM7600A, SIM7600A-H and SIM7600V-H do not support SD card. If unused, keep them open.
SD_DATA2	24	I/O		
SD_DATA3	25	I/O		
SD_CLK	26	DO	SDIO clock	
USIM interface				
USIM_DATA	17	I/O,PU	USIM Card data I/O, which has been pulled up via a 10KR resistor to USIM_VDD internally. Do not pull it up or down externally.	
USIM_RST	18	DO	USIM Reset	
USIM_CLK	19	DO	USIM clock	
USIM_VDD	20	PO	Power output for USIM card, its output Voltage depends on USIM card type automatically. Its output current is up to 50mA.	
SPI interface				
SPI_CLK	6	DO	SPI clock output	
SPI_MISO	7	DI	SPI master in/slave out data	
SPI_MOSI	8	DO	SPI master out/slave in data	
SPI_CS	9	DO	SPI chip-select output	
USB interface				
USB_VBUS	11	DI,PD	Valid USB detection input with 3.0~5.25V detection	

			voltage	
USB_DN	12	I/O	Negative line of the differential, bi-directional USB signal.	
USB_DP	13	I/O	Positive line of the differential, bi-directional USB signal.	
USB_ID	16	DI	High-speed USB ID input	Keep it open.
UART interface				
RTS	66	DO	Request to send	
CTS	67	DI,PU	Clear to Send	
RXD	68	DI,PU	Receive Data	
RI	69	DOH	Ring Indicator	
DCD	70	DOH	Carrier detects	
TXD	71	DOH	Transmit Data	
DTR	72	DI,PU	DTE get ready	
I2C interface				
SCL	55	DO	I2C clock output	
SDA	56	I/O	I2C data input/output	
SDIO interface				
SDIO_DATA1	27	I/O	SDIO data1	
SDIO_DATA2	28	I/O	SDIO data2	
SDIO_CMD	29	DO	SDIO command	
SDIO_DATA0	30	I/O	SDIO data0	
SDIO_DATA3	31	I/O	SDIO data3	
SDIO_CLK	32	DO	SDIO clock	
HSIC interface				
HSIC_STROBE	35	I/O	HSIC strobe wakeup	<i>If use, please refer to document [27]</i>
HSIC_DATA	36	I/O	HSIC data	Otherwise please keep them open.
PCM interface				
PCM_OUT	73	DO	PCM data output.	
PCM_IN	74	DI	PCM data input.	
PCM_SYNC	75	DO	PCM data frame sync signal.	If unused, please keep them open.
PCM_CLK	76	DO	PCM data bit clock.	
GPIO				
NETLIGHT	51	DO	LED control output as network status indication.	
FLIGHTMODE	54	DI,PU	Flight Mode control input. High level(or open): Normal Mode Low level: Flight Mode	If unused, keep them open. DO NOT PULL UP GPIO43 DURING NORMAL POWER UP!
STATUS	49	DO	Operating status output. High level: Power on and firmware ready Low level: Power off	

GPIO41	52	IO	GPIO	
GPIO43	50	IO	GPIO	
GPIO3	33	IO	GPIO	
GPIO6	34	IO	GPIO	
SD_DET	48	IO	Default: GPIO Optional: SD card detecting input. H: SD card is removed L: SD card is inserted	
USIM_DET	53	IO	Default: GPIO Optional: USIM card detecting input. H: USIM is removed L: USIM is inserted	
GPIO77	87	IO	GPIO	
RF interface				
MAIN_ANT	82	AIO	MAIN antenna soldering pad	
GNSS_ANT	79	AI	GNSS antenna soldering pad	
AUX_ANT	59	AI	Auxiliary antenna soldering pad	
Other interface				
ISINK	45	PI	Ground-referenced current sink.	
ADC1	47	AI	Analog-digital converter input 1	If unused, please keep them open.
ADC2	46	AI	Analog-digital converter input 2	
COEX1	83	I/O	RF synchronizing between Wi-Fi and LTE.	If unused, keep them open.
COEX2	84	I/O		DO NOT PULL UP COEX1 AND COEX3 DURING NORMAL POWER UP!
COEX3	86	I/O		
USB_BOOT	85	DI,PD	Boot configuration input. Module will be forced into USB download mode by connect 85 pin to VDD_1V8 during power up.	Do place 2 test points for debug. DO NOT PULL UP USB_BOOT DURING NORMAL POWER UP!
NC	42		No connection.	Keep it open

2.3 Mechanical Information

The following figure shows the package outline drawing of module.

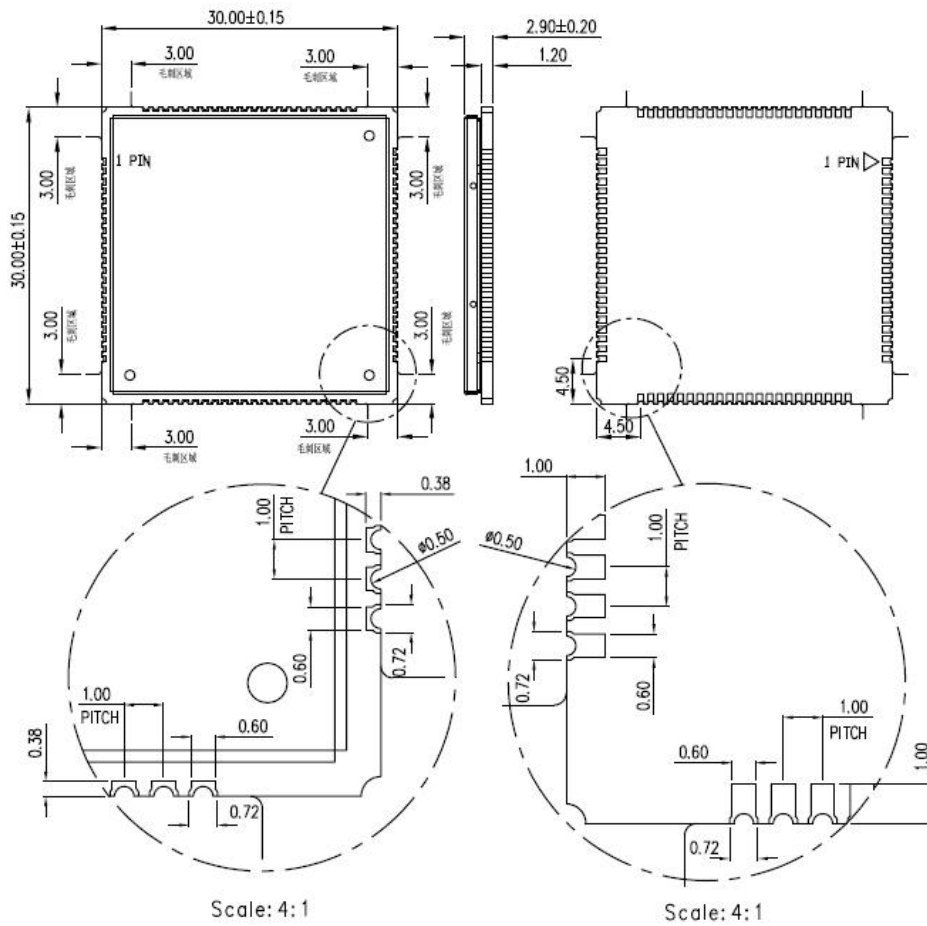

Figure 3: Dimensions (Unit: mm)

2.4 Footprint Recommendation

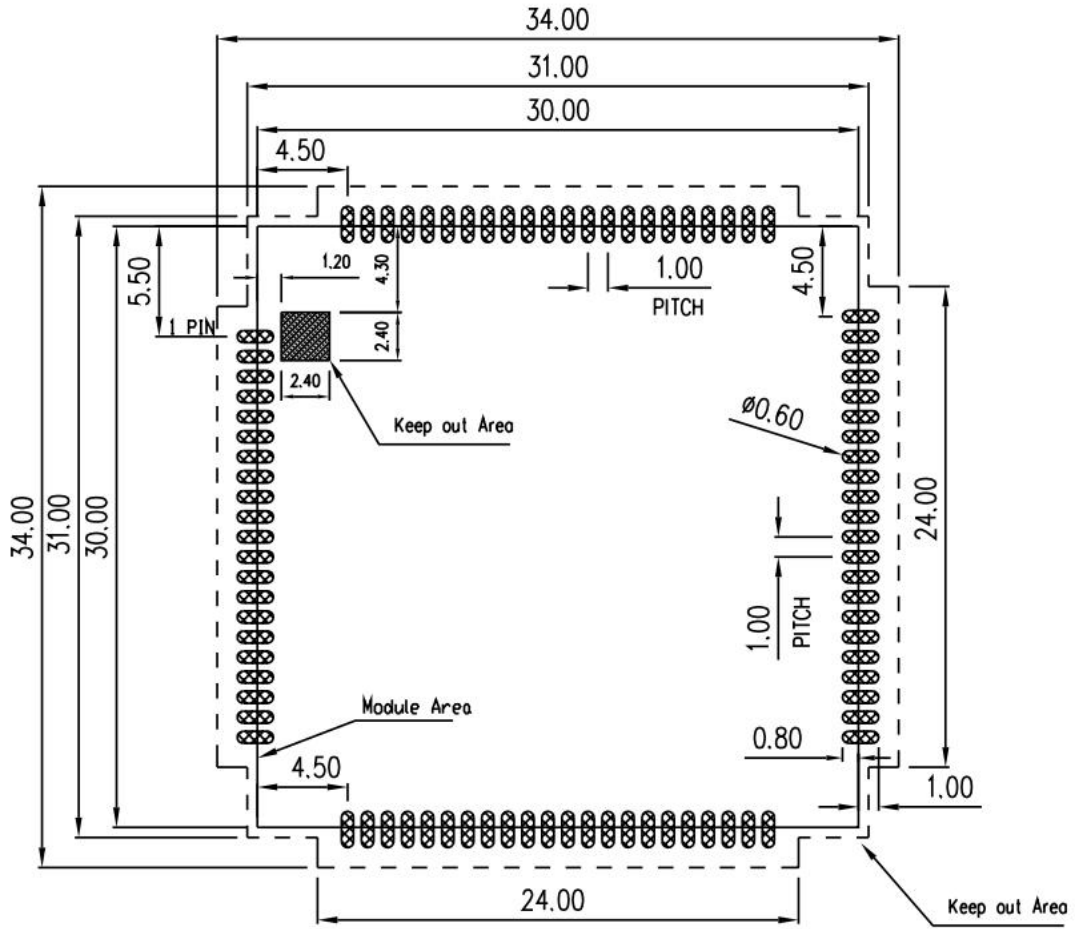

Figure 4: Footprint recommendation (Unit: mm)

Confidential

3 Interface Application

3.1 Power Supply

The power supply pins of module include 4 pins (pin 62&63, pin 38&39) named VBAT.

The 4 VBAT pads supply the power to RF and baseband circuits directly. On VBAT pads, the ripple current up to 2A typically, due to GSM/GPRS emission burst (every 4.615ms), may cause voltage drop. So the power supply for these pads must be able to provide sufficient current up to more than 2A in order to avoid the voltage drop is more than 300mV.

The following figure shows the VBAT voltage ripple wave at the maximum power transmit phase.

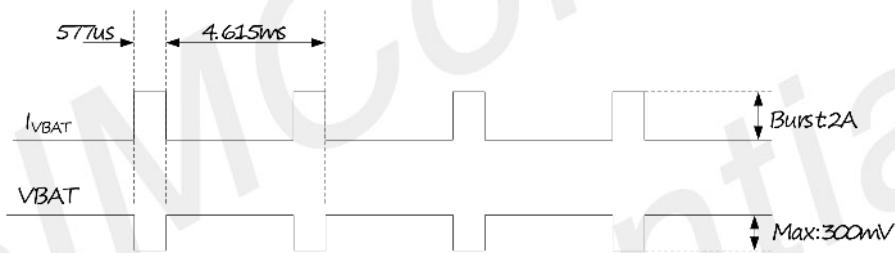

Figure 5: VBAT voltage drop during burst emission (GSM/GPRS)

NOTE

The test condition: The voltage of power supply for VBAT is 3.8V, Cd=100 μ F tantalum capacitor (ESR=0.7 Ω) and Cf=100nF (Please refer to Figure 6—Application circuit).

Table 6: VBAT pins electronic characteristic

Symbol	Description	Min.	Typ.	Max.	Unit
VBAT	Module power voltage	3.4	3.8	4.2	V
I _{VBAT(peak)}	Module power peak current in normal mode.	-	2	-	A
I _{VBAT(average)}	Module power average current in normal mode	Please refer to the table 42			
I _{VBAT (sleep)}	Power supply current in sleep mode				
I _{VBAT (power-off)}	Module power current in power off mode.				20 uA

3.1.1 Power Supply Design Guide

Make sure that the voltage on the VBAT pins will never drop below 3.4V, even during a transmit burst, when current consumption may rise up to 2A. If the voltage drops below 3.4V, the RF performance may be affected.

NOTE

If the power supply for VBAT pins can support up to 2A, more than 300uF capacitors are recommended. Otherwise users must use a total of 1000uF capacitors typically, in order to avoid of the voltage drop more than 300mV.

Some multi-layer ceramic chip (MLCC) capacitors (0.1/1uF) with low ESR in high frequency band can be used for EMC.

These capacitors should be put as close as possible to VBAT pads. Also, users should keep VBAT trace on circuit board wider than 2 mm to minimize PCB trace impedance. The following figure shows the recommended circuit. Recommend part of FB101 is BLM21PG300SN1D or MPZ2012S221A.

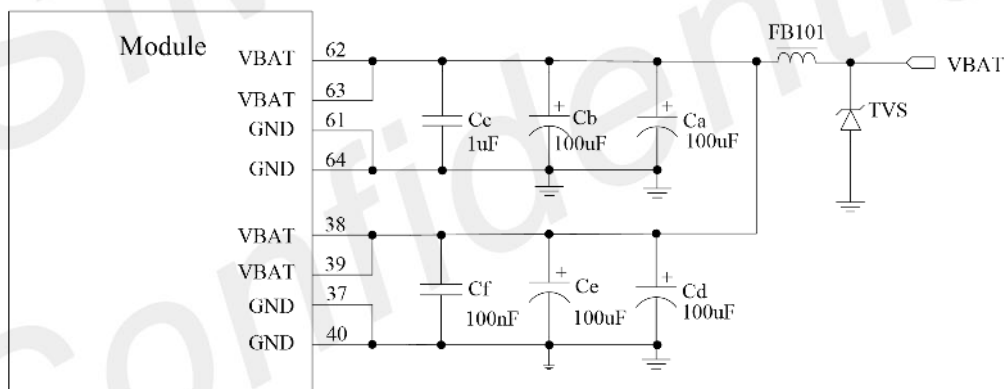

Figure 6: Power supply application circuit

In addition, in order to guard for ESD or surge protection, it is suggested to use a TVS to protect the module.

NOTE

Customer could only power pin 62, 63 or only power pin 38, 39, for these pins are connected inside the module.

Table 7: Recommended TVS list

No	Manufacturer	Part Number	Reverse Stand-Off Voltage	Package
1	Js-ele	ESDBW5V0A1	5V	DFN1006-2L
2	Prisem	PESDHC2FD4V5BH	4.5V	DFN1006-2L
3	Way-on	WS05DPF-B	5V	DFN1006-2L
4	Will semi	ESD5611N	5V	DFN1006-2L
5	Will semi	ESD56151W05	5V	SOD-323
6	Way-on	WS4.5DPV	4.5V	DFN1610-2L

3.1.2 Recommended Power Supply Circuit

It is recommended that a switching mode power supply or a linear regulator power supply is used. It is important to make sure that all the components used in the power supply circuit can resist a peak current up to 2A.

The following figure shows the linear regulator reference circuit with 5V input and 3.8V output.

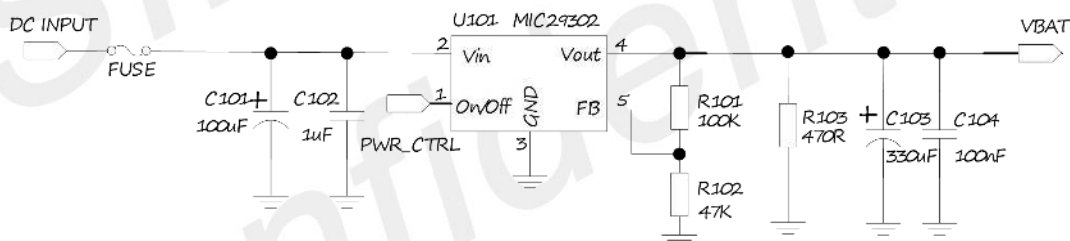

Figure 7: Linear regulator reference circuit

If there is a big voltage difference between input and output for VBAT power supply, or the efficiency is extremely important, then a switching mode power supply will be preferable. The following figure shows the switching mode power supply reference circuit.

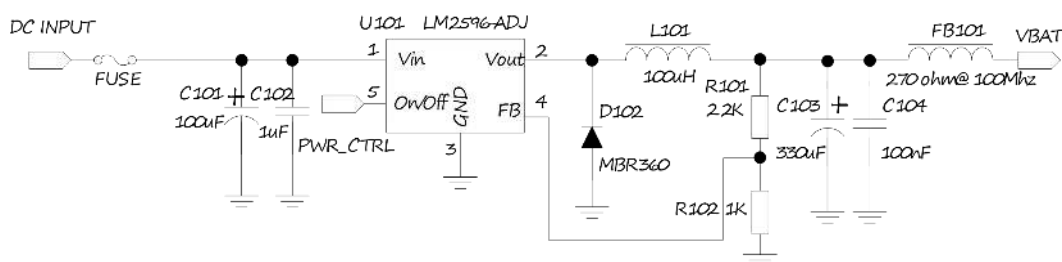

Figure 8: Switching mode power supply reference circuit

NOTE

1. The Switching Mode power supply solution for VBAT must be chosen carefully against Electro Magnetic Interference and ripple current from depraving RF performance.
2. If the DC input is 12V, customer must select a buck circuit to get better power efficiency.

3.1.3 Voltage Monitor

To monitor the VBAT voltage, the AT command “AT+CBC” can be used.

For monitoring the VBAT voltage outside or within a special range, the AT command “AT+CVALARM” can be used to enable the under-voltage warning function.

If users need to power off module, when the VBAT voltage is out of a range, the AT command “AT+CPMVT” can be used to enable under-voltage power-off function.

NOTE

Under-voltage warning function and under-voltage power-off function are disabled by default. For more information about these AT commands, please refer to Document [1].

3.2 Power on/Power off/Reset Function

3.2.1 Power on

Module can be powered on by pulling the PWRKEY pin down to ground.

The PWRKEY pin has been pulled up with a diode to 1.8V internally, so it does not need to be pulled up externally. It is strongly recommended to put an ESD protection diode, close to the PWRKEY pin as it would strongly enhance the ESD performance of PWRKEY pin. Please refer to the following figure for the recommended reference circuit.

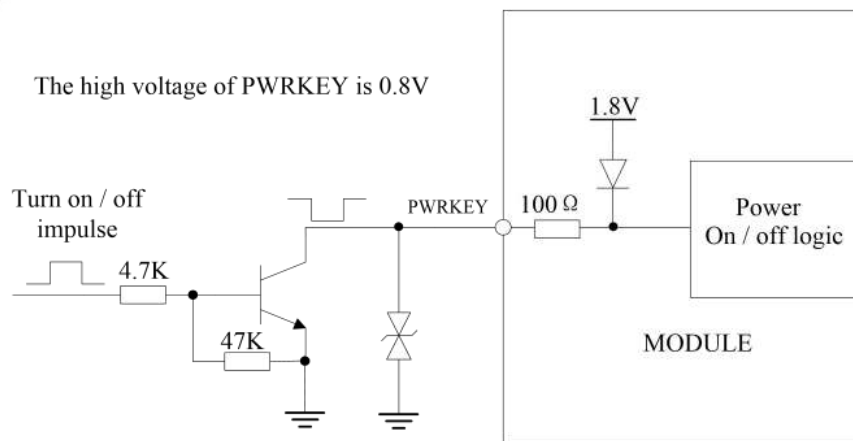

Figure 9: Reference power on/off circuit

NOTE

Module could be automatically power on by connecting PWRKEY pin to ground via 0R resistor directly.

The power-on scenarios are illustrated in the following figure.

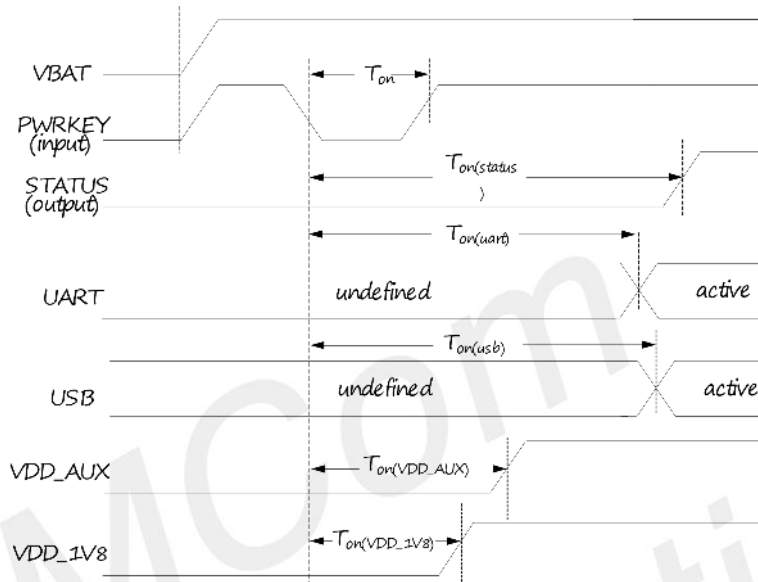

Figure 10: Power on timing sequence

Table 8: Power on timing and electronic characteristic

Symbol	Parameter	Min.	Typ.	Max.	Unit
T_{on}	The time of active low level impulse of PWRKEY pin to power on module	100	500	-	ms
$T_{on(status)}$	The time from power-on issue to STATUS pin output high level(indicating power up ready)	12	16	-	s
$T_{on(uart)}$	The time from power-on issue to UART port ready	11	12	-	s
$T_{on(vdd_aux)}$	The time from power-on issue to VDD_AUX ready	-	2.5	-	s
$T_{on(vdd_1v8)}$	The time from power-on issue to VDD_1V8 ready	100	-	-	ms
$T_{on(usb)}$	The time from power-on issue to USB port ready	11	12	-	s
V_{IH}	Input high level voltage on PWRKEY pin	0.6	0.8	1.8	V
V_{IL}	Input low level voltage on PWRKEY pin	-0.3	0	0.5	V

3.2.2 Power off

The following methods can be used to power off module.

- Method 1: Power off module by pulling the PWRKEY pin down to ground.
- Method 2: Power off module by AT command “AT+CPOF”.
- Method 3: over-voltage or under-voltage automatic power off. The voltage range can be set by AT command “AT+CPMVT”.
- Method 4: over-temperature or under-temperature automatic power off.

NOTE

If the temperature is outside the range of $-30\sim+80^{\circ}\text{C}$, some warning will be reported via AT port. If the temperature is outside the range of $-40\sim+85^{\circ}\text{C}$, module will be powered off automatically. For details about “AT+CPOF” and “AT+CPMVT”, please refer to Document [1].

These procedures will make module disconnect from the network and allow the software to enter a safe state, and save data before module be powered off completely.

The power off scenario by pulling down the PWRKEY pin is illustrated in the following figure.

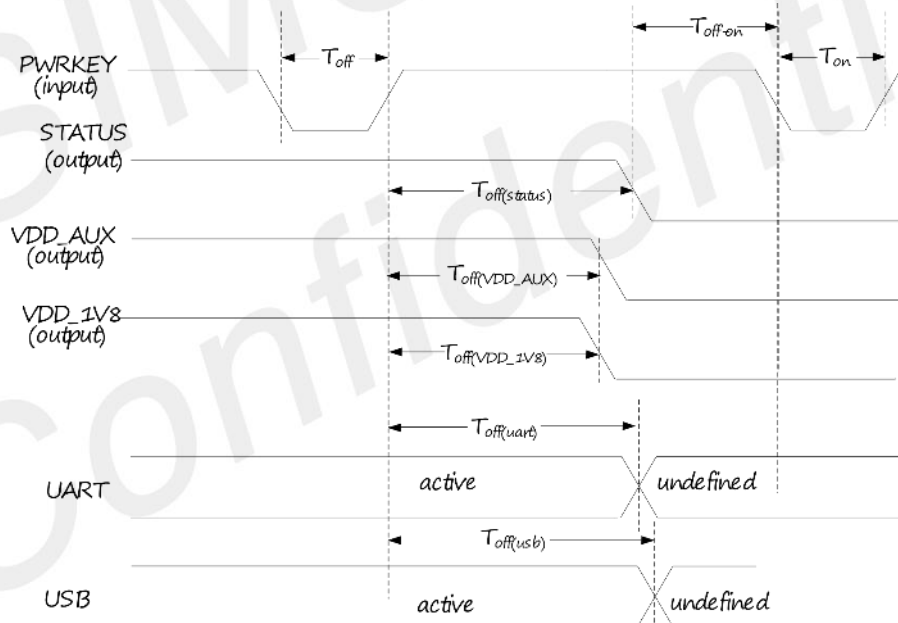

Figure 11: Power off timing sequence

Table 9: Power off timing and electronic characteristic

Symbol	Parameter	Min.	Typ.	Max.	Unit
T_{off}	The active low level time pulse on PWRKEY pin to power off module	2.5	--	5.0	s
$T_{off(status)}$	The time from power-off issue to STATUS pin output low level(indicating power off)*	25	26	-	s
$T_{off(uart)}$	The time from power-off issue to UART port off	14	15	-	s

$T_{off(usb)}$	The time from power-off issue to USB port off	27	28	-	s
$T_{off(VDD_AUX)}$	The time from power-off issue to vdd_aux off	20	-	-	s
$T_{off(VDD_1V8)}$	The time from power-off issue to vdd_1V8f	20	-	-	s
T_{off-on}	The buffer time from power-off issue to power-on issue	0	-	-	s

NOTE

1. The STATUS pin can be used to detect whether module is powered on or not. When module has been powered on and firmware goes ready, STATUS will be high level, or else STATUS will still low level.
2. It is suggested that the host can cut off the power off the module, when the module could not switch off by PWRKEY of RESET interface, customer could cut off the power to restart the module.
3. If the PWERKY and RESET key works normally, it is not suggested to switch off module by remove the power supply for that might damage the flash.
4. The power off time may vary for the local net status.

3.2.3 Reset Function

Module can be reset by pulling the RESET pin down to ground.

NOTE

This function is only used as an emergency reset, when AT command “AT+CPOF” and the PWRKEY pin all have lost efficacy.

The RESET pin has been pulled up with a 40KΩ resistor to 1.8V internally, so it does not need to be pulled up externally. It is strongly recommended to put a 100nF capacitor and an ESD protection diode close to the RESET pin. Please refer to the following figure for the recommended reference circuit.

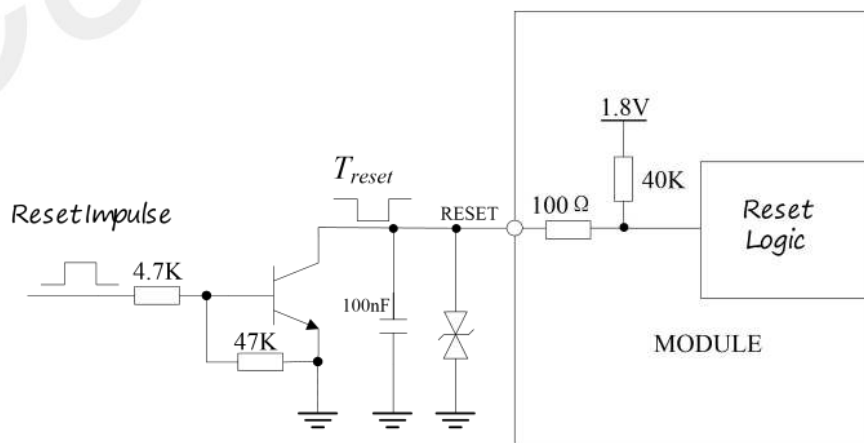

Figure 12: Reference reset circuit

Customers can RESET by pulling down the RESET signal, and the RESET time sequence diagram is shown in the following figure:

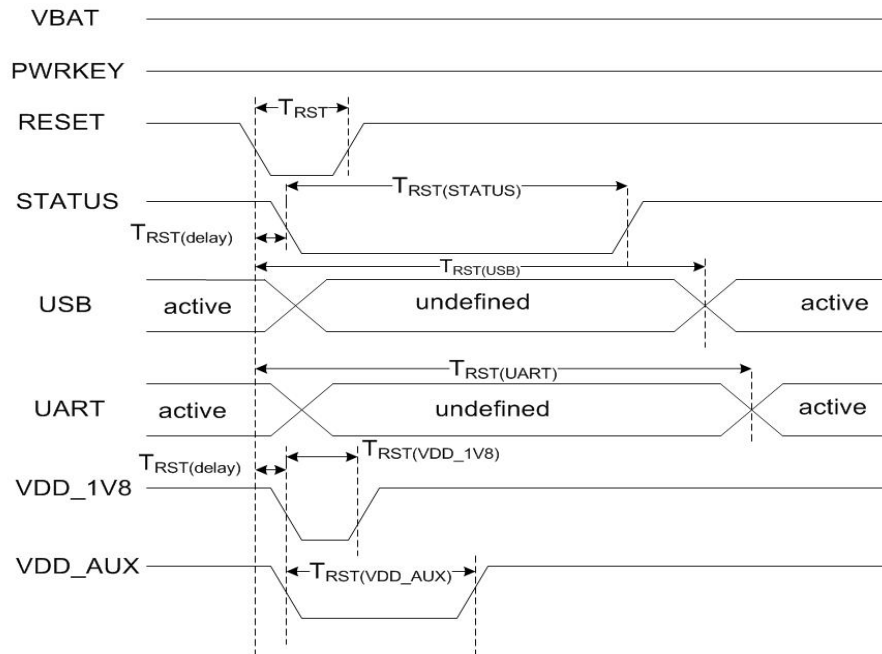

Figure 13: Reset timing sequence

Table 10: Reset timing parameters

Symbol	Parameter	Min.	Typ.	Max.	Unit
T_{RST}	The active low level time impulse on RESET pin to reset module	100	200	500	ms
$T_{RST(delay)}$	STATUS VDD_1V8 VDD_AUX delay time	95	100		ms
$T_{RST(STATUS)}$	The Reset time (According to the STATUS pin judge)	13	14		s
$T_{RST(USB)}$	The Reset time (According to the USB judge)	11	12		s
$T_{RST(UART)}$	The Reset time (According to the UART judge)	12	13		s
$T_{RST(VDD_1V8)}$	The Reset time (According to the VDD_1V8 judge)	60	80		ms
$T_{RST(VDD_AUX)}$	The Reset time (According to the VDD_AUX judge)	2.3	2.5	3	s
V_{IH}	Input high level voltage	1.17	1.8	2.1	V
V_{IL}	Input low level voltage	-0.3	0	0.8	V

NOTE

1. When the module could not switch off by PWRKEY of RESET interface, customer should cut off the power to restart the module.
2. If the PWERKY and RESET key works normally, it is not suggested to switch off module by remove the power supply for that might damage the flash.

3.3 UART Interface

Module provides a 7-wire UART (universal asynchronous serial transmission) interface as DCE (Data Communication Equipment). AT commands and data transmission can be performed through UART interface.

3.3.1 UART Design Guide

The following figures show the reference design.

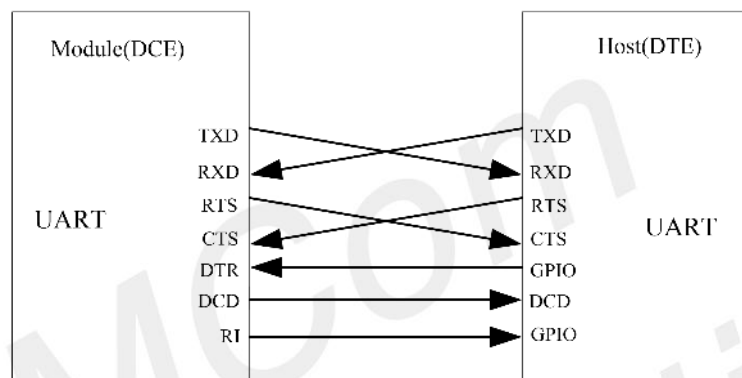

Figure 14: UART full modem

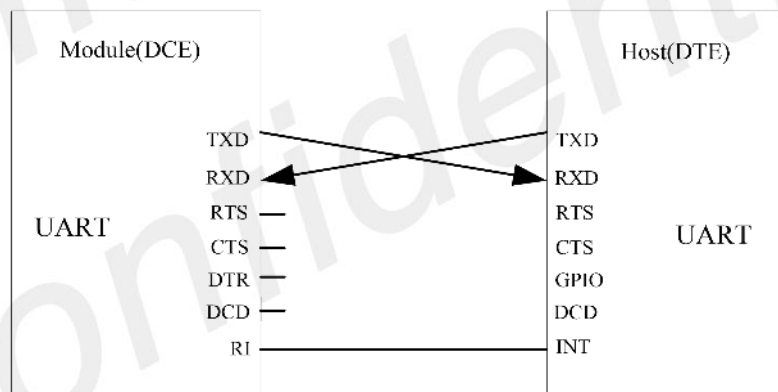

Figure 15: UART null modem

The module UART is 1.8V voltage interface. If user's UART application circuit is 3.3V voltage interface, the level shifter circuits should be used for voltage matching. The TXB0108RGYR provided by Texas Instruments is recommended. The following figure shows the voltage matching reference design.

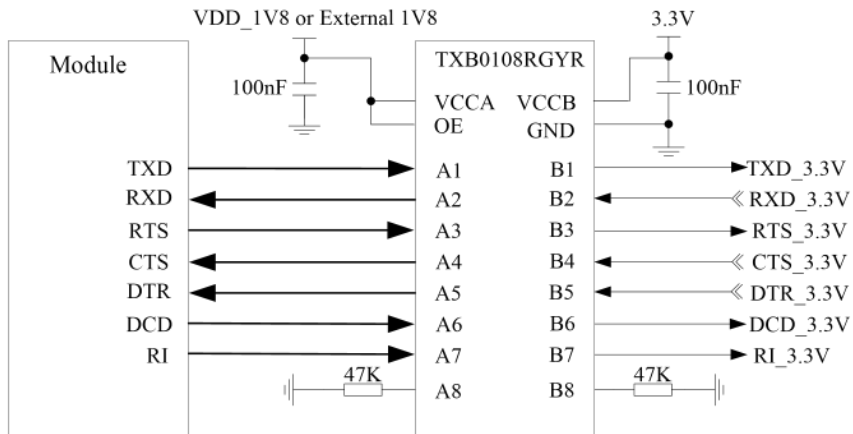

Figure 16: Reference circuit of level shift

Customers can use another level shifter circuits as follow.

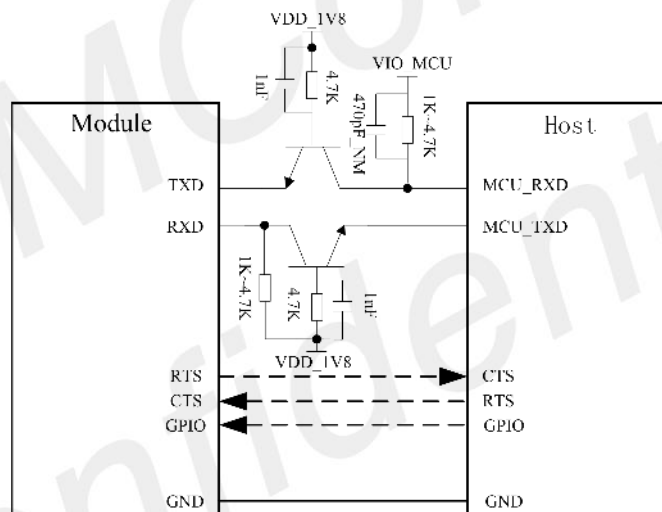

Figure 17: Level matching circuit with triode

NOTE

1. User need to use high speed transistors such as MMBT3904.
2. Module supports the following baud rates: 300, 600, 1200, 2400, 4800, 9600, 19200, 38400, 57600, 115200, 230400, 460800, 921600, 3200000, 3686400bps. The default band rate is 115200bps.

3.3.2 RI and DTR Behavior

The RI pin can be used to interrupt output signal to inform the host controller such as application CPU.

Normally RI will keep high level until certain conditions such as receiving SMS, or a URC report coming, and then it will change to low level.

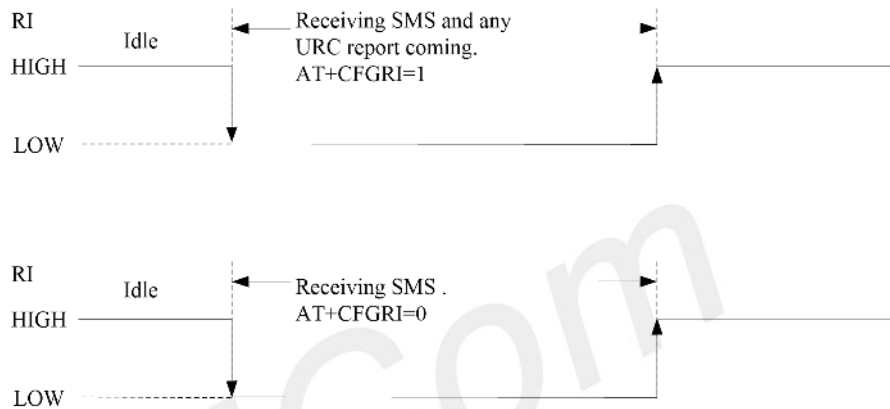

Figure 18: RI behaviour (SMS and URC report)

Normally RI will be kept at a high level until a voice call, then it will output periodic rectangular wave with 5900ms low level and 100ms high level. It will output this kind of periodic rectangular wave until the call is answered or hung up.

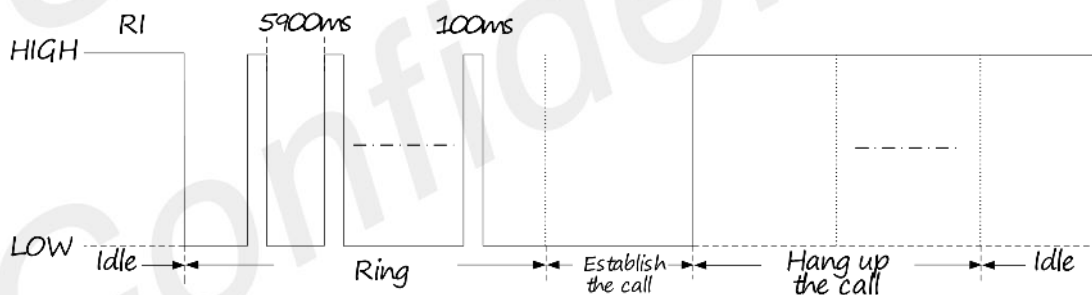

Figure 19: RI behaviour (voice call)

NOTE

For more details of AT commands about UART, please refer to document [1] and [22].

DTR pin can be used to wake module from sleep. When module enters sleep mode, pulling down DTR can wake module.

3.4 USB Interface

The module contains a USB interface compliant with the USB2.0 specification as a peripheral, but the USB charging function is not supported.

3.4.1 USB diagram

Module can be used as a USB device. module supports the USB suspend and resume mechanism which can reduce power consumption. If there is no data transmission on the USB bus, module will enter suspend mode automatically, and will be resumed by some events such as voice call, receiving SMS, etc. The USB interface is a frequency used debug port; it is suggested to reserved test point.

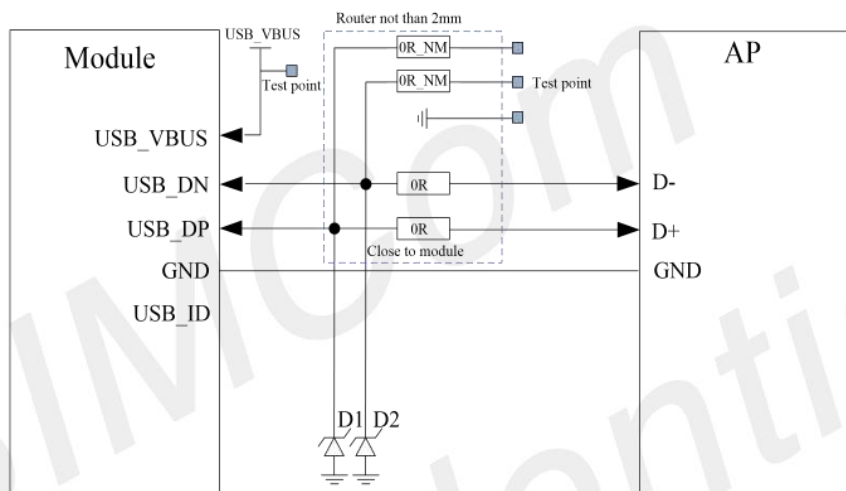

Figure 20: USB reference circuit

Because of the high bit rate on USB bus, more attention should be paid to the influence of the junction capacitance of the ESD component on USB data lines. Typically, the capacitance should be less than 1pF. It is recommended to use an ESD protection component such as ESD9L5.0ST5G provided by On Semiconductor (www.onsemi.com).

NOTE

The USB_DN and USB_DP nets must be traced by 90Ohm+/-10% differential impedance.

3.4.2 USB_BOOT

Module can enter in force download mode by USB_BOOT.

Table 11: USB_BOOT description

PIN No	PIN Name	I/O	description	Power domain	Default status	Index
85	USB_BOOT	DI	USB boot	1.8V	B-PD	

If the module download failed, then customer can make module enter download mode via this Pin. Before the module power on, pull up the USB_BOOT to VDD_1V8, then push the PWRKEY to power on module, when the module enter download mode, the pull up should be removed.

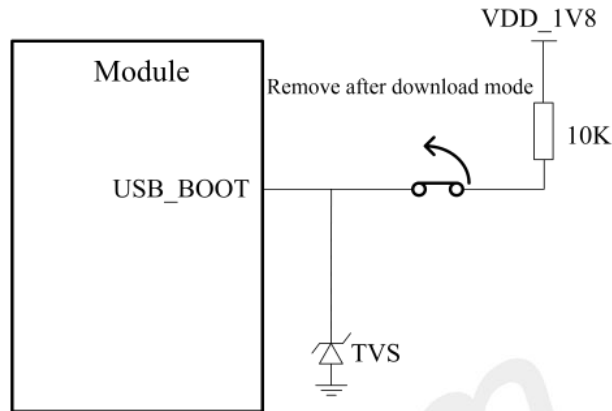

Figure 21: USB_BOOT circuit

Customer can check the download port in the device management.



Figure 22: Force download port

3.4.3 USB_ID

Module support OTG function, but the USB_VBUS(PIN 11) cannot supply device with 5V, so customer should design the circuit to power the USB device.

For the detail circuit, customer could refer to *SIM7600 Series EMMC-Reference Design*.

Table 12: USB_ID description

PIN No	PIN Name	I/O	Function description	Domain	Default Status	index
16	USB_ID	DI	High level: module in USB device mode. Low level: module in USB host mode.	1.8V	DI-PH	

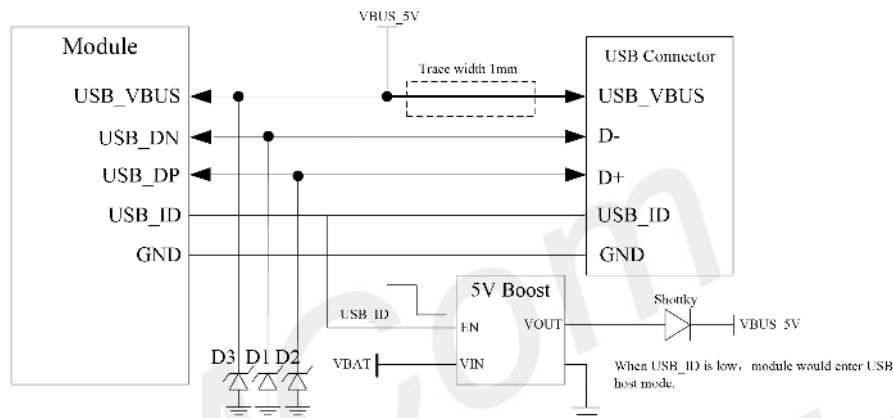

Figure 23: USB_OTG diagram

3.5 USIM Interface

Module supports both 1.8V and 3.0V USIM Cards.

Table 13: USIM electronic characteristic in 1.8V mode (USIM_VDD=1.8V)

Symbol	Parameter	Min.	Typ.	Max.	Unit
USIM_VDD	LDO power output voltage	1.75	1.8	1.95	V
V _{IH}	High-level input voltage	0.65*USIM_VDD	-	USIM_VDD +0.3	V
V _{IL}	Low-level input voltage	-0.3	0	0.35*USIM_VDD	V
V _{OH}	High-level output voltage	USIM_VDD -0.45	-	USIM_VDD	V
V _{OL}	Low-level output voltage	0	0	0.45	V

Table 14: USIM electronic characteristic 3.0V mode (USIM_VDD=2.95V)

Symbol	Parameter	Min.	Typ.	Max.	Unit
USIM_VDD	LDO power output voltage	2.75	2.95	3.05	V
V _{IH}	High-level input voltage	0.65*USIM_VDD	-	USIM_VDD +0.3	V
V _{IL}	Low-level input voltage	-0.3	0	0.25*USIM_VDD	V
V _{OH}	High-level output voltage	USIM_VDD -0.45	-	USIM_VDD	V
V _{OL}	Low-level output voltage	0	0	0.45	V

3.5.1 USIM Application Guide

It is recommended to use an ESD protection component such as ESDA6V1W5 produced by ST (www.st.com) or SMF15C produced by ON SEMI (www.onsemi.com). Note that the USIM peripheral circuit should be close to the USIM card socket. The following figure shows the 6-pin SIM card holder reference circuit.

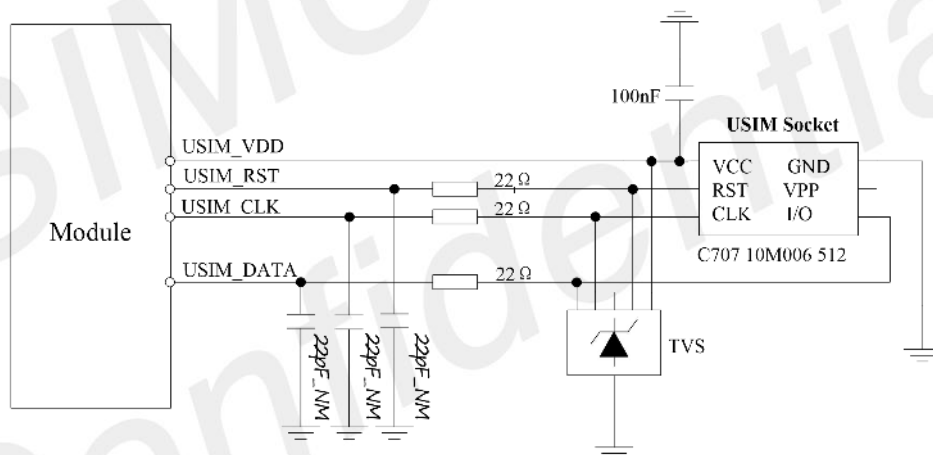

Figure 24: USIM interface reference circuit

NOTE

1. USIM_DATA has been pulled up with a 10KΩ resistor to USIM_VDD in module. A 100nF capacitor on USIM_VDD is used to reduce interference.
2. For more details of AT commands about USIM, please refer to document [1]. USIM_CLK is very important signal, the rise time and fall time of USIM_CLK should be less than 40ns, otherwise the USIM card might not be initialized correctly.

The USIM_DET pin is used for detection of the USIM card hot plug in. User can select the 8-pin USIM card holder to implement USIM card detection function.

The following figure shows the 8-pin SIM card holder reference circuit.

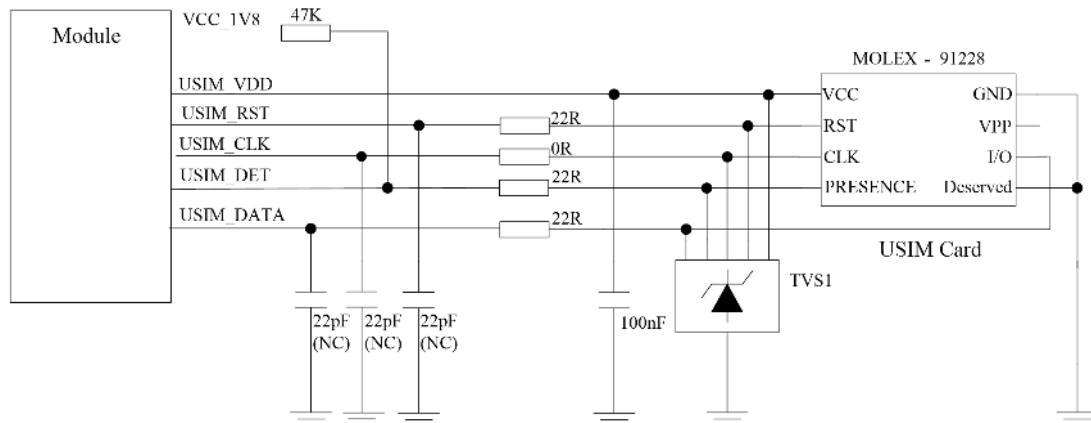

Figure 25: USIM interface reference circuit with USIM_DET

If the USIM card detection function is not used, user can keep the USIM_DET pin open.

3.5.2 USIM Design Notice

USIM card circuit is susceptible; the interference may cause the SIM card failures or some other situations, so it is strongly recommended to follow these guidelines while designing:

- Make sure that the SIM card holder should be far away from the antenna while in PCB layout.
- SIM traces should keep away from RF lines, VBAT and high-speed signal lines.
- The traces should be as short as possible.
- Keep SIM holder's GND connect to main ground directly.
- Shielding the SIM card signal by ground.
- Recommended to place a 0.1~1uF capacitor on USIM_VDD line and keep close to the holder.
- The rise/fall time of USIM_CLK should not be more than 40ns.
- Add some TVS and the parasitic capacitance should not exceed 60pF.

3.5.3 Recommended USIM Card Holder

It is recommended to use the 6-pin USIM socket such as C707 10M006 512 produced by Amphenol. User can visit <http://www.amphenol.com> for more information about the holder.

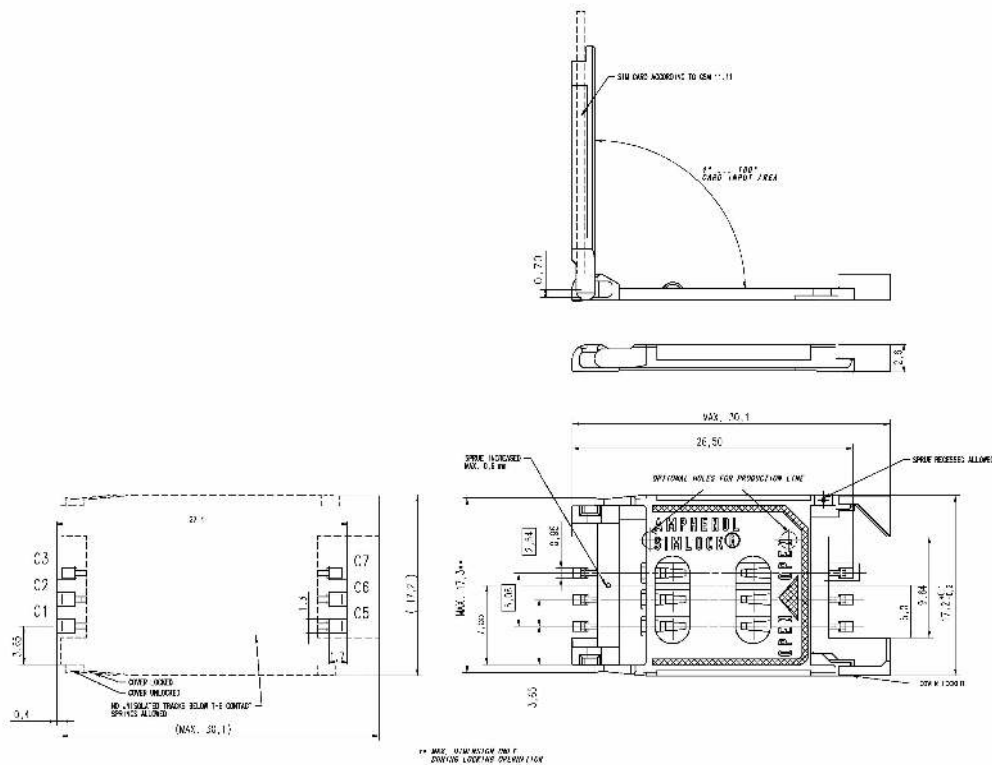

Figure 26: Amphenol SIM card socket

Table 15: Amphenol USIM socket pin description

Pin	Signal	Description
C1	USIM_VDD	USIM Card Power supply.
C2	USIM_RST	USIM Card Reset.
C3	USIM_CLK	USIM Card Clock.
C5	GND	Connect to GND.
C6	VPP	
C7	USIM_DATA	USIM Card data I/O.

3.6 PCM Interface

Module provides a PCM interface for external codec, which can be used in master mode with short sync and 16 bits linear format.

Table 16: PCM format

Characteristics	Specification
Line Interface Format	Linear(Fixed)
Data length	16bits(Fixed)
PCM Clock/Sync Source	Master Mode(Fixed)

PCM Clock Rate	2048kHz (2G/3G), 4096Khz (4G)
PCM Sync Format	Short sync(Fixed)
Data Ordering	MSB

NOTE

For more details about PCM AT commands, please refer to document [1].

3.6.1 PCM timing

Module supports 2.048 MHz PCM data and sync timing for 16 bits linear format codec.

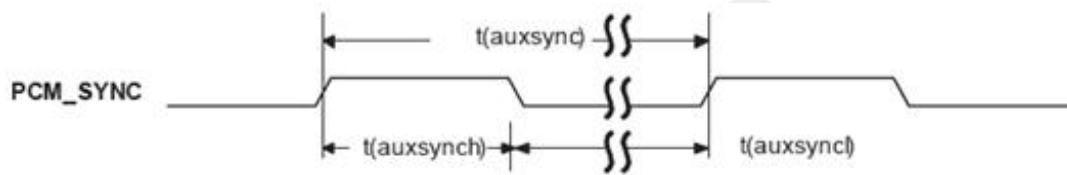

Figure 27: PCM_SYNC timing

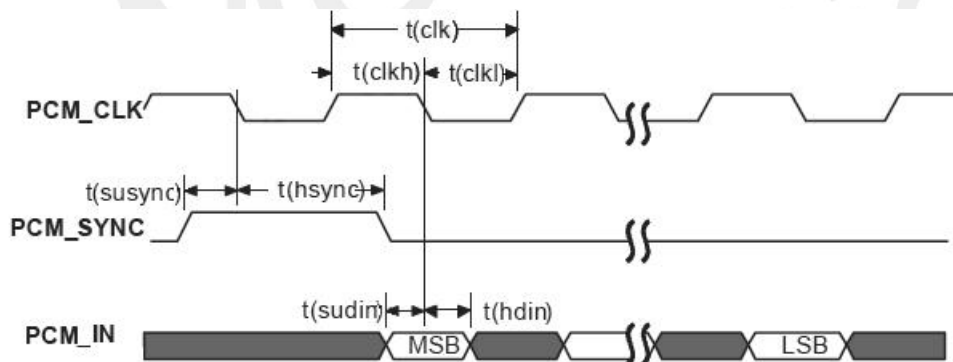

Figure 28: EXT codec to module timing

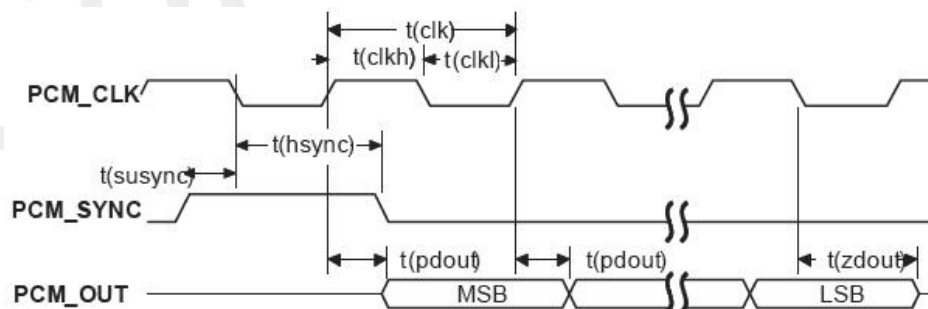

Figure 29: Module to EXT codec timing

Table 17: PCM timing parameters (2G/3G mode)

Symbol	Parameter	Min.	Typ.	Max.	Unit
T(sync)	PCM_SYNC cycle time	–	125	–	μs
T(synch)	PCM_SYNC high level time	–	488	–	ns
T(sync _l)	PCM_SYNC low level time	–	124.5	–	μs
T(clk)	PCM_CLK cycle time	–	488	–	ns
T(clk _h)	PCM_CLK high level time	–	244	–	ns
T(clk _l)	PCM_CLK low level time	–	244	–	ns
T(susync)	PCM_SYNC setup time high before falling edge of PCM_CLK	–	244	–	ns
T(hsync)	PCM_SYNC hold time after falling edge of PCM_CLK	–	244	–	ns
T(sudin)	PCM_IN setup time before falling edge of PCM_CLK	60	–	–	ns
T(hdin)	PCM_IN hold time after falling edge of PCM_CLK	10	–	–	ns
T(pdout)	Delay from PCM_CLK rising to PCM_OUT valid	–	–	60	ns
T(zdout)	Delay from PCM_CLK falling to PCM_OUT HIGH-Z	–	160	–	ns

Table 18: PCM timing parameters (4G mode)

Symbol	Parameter	Min.	Typ.	Max.	Unit
T(sync)	PCM_SYNC cycle time	–	62.5	–	μs
T(synch)	PCM_SYNC high level time	–	244	–	ns
T(sync _l)	PCM_SYNC low level time	–	62.256	–	μs
T(clk)	PCM_CLK cycle time	–	244	–	ns
T(clk _h)	PCM_CLK high level time	–	122	–	ns
T(clk _l)	PCM_CLK low level time	–	122	–	ns
T(susync)	PCM_SYNC setup time high before falling edge of PCM_CLK	–	122	–	ns
T(hsync)	PCM_SYNC hold time after falling edge of PCM_CLK	–	122	–	ns
T(sudin)	PCM_IN setup time before falling edge of PCM_CLK	122	–	–	ns
T(hdin)	PCM_IN hold time after falling edge of PCM_CLK	122	–	–	ns
T(pdout)	Delay from PCM_CLK rising to PCM_OUT valid	–	–	122	ns
T(zdout)	Delay from PCM_CLK falling to PCM_OUT HIGH-Z	–	–	122	ns

3.6.2 PCM Application Guide

The following figure shows the external codec reference design.

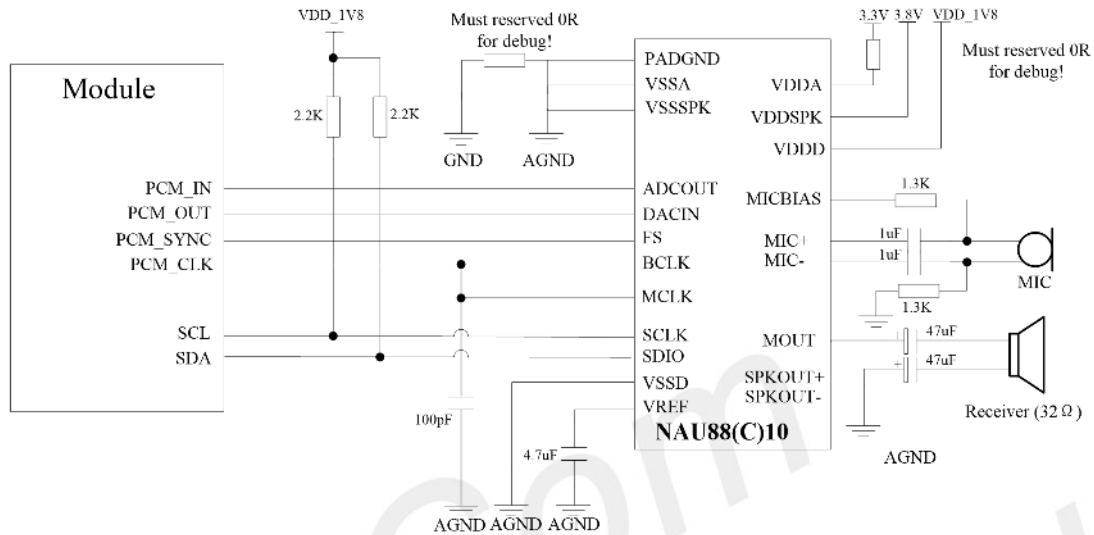

Figure 30: Audio codec reference circuit

3.7 SD Interface

Module provides a 4-bit SD/MMC interface with clock rate up to 200 MHz, The voltage of MMC/SD interface is 2.85V, which is compatible with SDIO Card Specification (version 3.0) and Secure Digital (Physical Layer Specification, version 3.0). It supports up to 32GB SD cards.

Table 19: MMC/SD electronic characteristic (SD_DATA0-SD_DATA3, SD_CLK and SD_CMD) *

Symbol	Parameter	Min.	Typ.	Max.	Unit
V _{IH}	High-level input voltage	0.65*2.85	-	2.85+0.3	V
V _{IL}	Low-level input voltage	-0.3	0	0.25*2.85	V
V _{OH}	High-level output voltage	2.85-0.4	2.85	2.85	V
V _{OL}	Low-level output voltage	0	0	0.45	V

NOTE

SD_DET is 1.8V operation voltage ,which is different from SD_DATA0-SD_DATA3, SD_CLK or SD_CMD.

Users should provide 2.85V to power SD card system and the current should more than 500mA, which is showed below as VDD_SD. ESD/EMI components should be arranged beside SD card socket. Refer to the following application circuit.

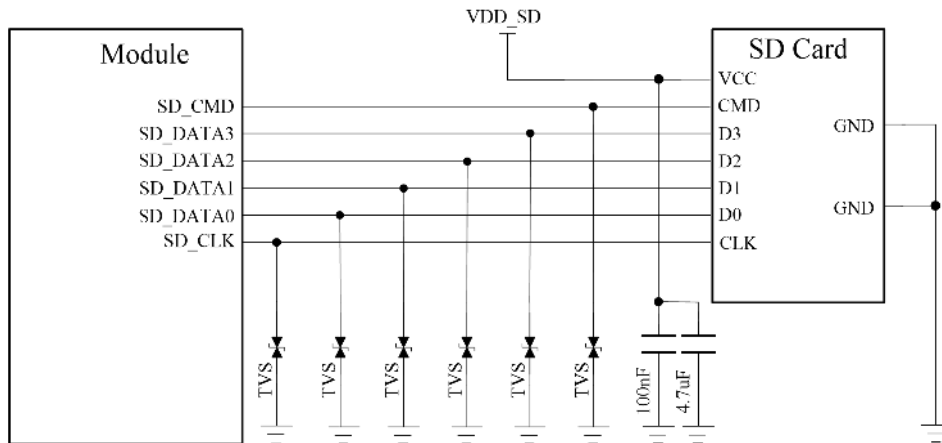

Figure 31: SD reference circuit

SD card layout guide lines:

- Protect other sensitive signals/circuits from SD card signals.
- Protect SD card signals from noisy signals (clocks, SMPS, etc.).
- Up to 200 MHz clock rate, 50 Ω nominal, $\pm 10\%$ trace impedance
- CLK to DATA/CMD length matching < 1 mm
- 15–24 Ω termination resistor on clock lines near module
- Total routing length < 50 mm recommended
- Routing distance from module clock pin to termination resistor < 5 mm
- Spacing to all other signals = 2x line width
- Bus capacitance < 15 pF

3.8 I2C Interface

Module provides a I2C interface compatible with I2C specification, version 5.0, with clock rate up to 400 kbps. Its operation voltage is 1.8V.

The following figure shows the I2C bus reference design.

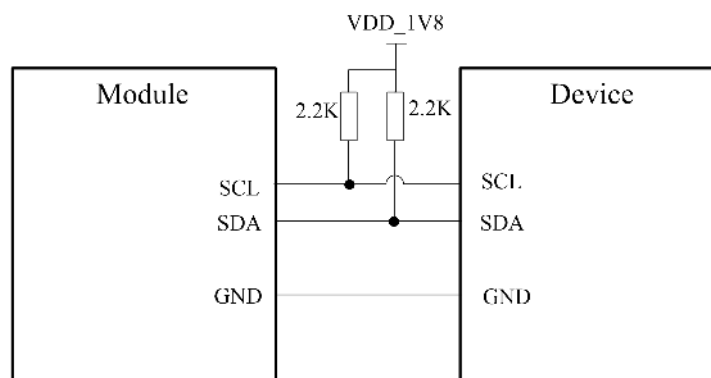

Figure 32: I2C reference circuit

NOTE

1. SDA and SCL do not have pull-up resistors in module. So, 2 externals pull up resistors are needed in application circuit.
2. If the I/O of slave device is 3.3V, then the level shifter circuits should be needed.
3. "AT+CR1IC and AT+CWIIC" AT commands could be used to read/write register values of the I2C peripheral devices.
4. For more details about AT commands please refer to document [1].

3.9 SDIO Interface

Module provides a 4 bit 1.8V SDIO interface for WLAN solution with W58 module.

NOTE

Special software version for CAT4 modules support this function.

3.10 SPI Interface

Module provides a SPI interface as a master only. Its operation voltage is 1.8V, and its clock rate is up to 26 MHz.

NOTE

This function is reserved. For detail information please contact with FAE.

3.11 Network Status

The NETLIGHT pin is used to control Network Status LED, its reference circuit is shown in the following figure.

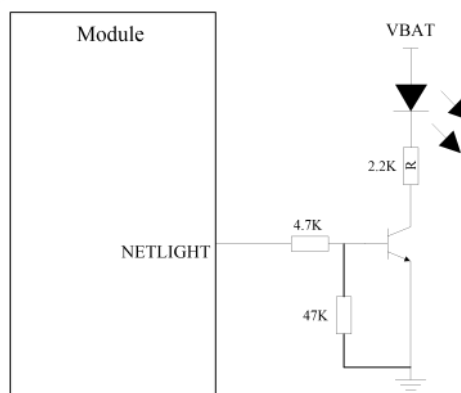

Figure 33: NETLIGHT reference circuit

NOTE

The value of the resistor named "R" depends on the LED characteristic.

Table 20: NETLIGHT pin status

NETLIGHT pin status	Module status
Always On	Searching Network; Call Connect (include VOLTE,SRLTE)
200ms ON, 200ms OFF	Data Transmit; 4G registered;
800ms ON, 800ms OFF	2G/3G registered network
OFF	Power off; Sleep

NOTE

NETLIGHT output low level as “OFF”, and high level as “ON”.

3.12 Flight Mode Control

The FLIGHTMODE pin can be used to control module to enter or exit the Flight mode. In Flight mode, the RF circuit is closed to prevent interference with other equipment and minimize current consumption. Bidirectional ESD protection component is suggested to add on FLIGHTMODE pin, its reference circuit is shown in the following figure.

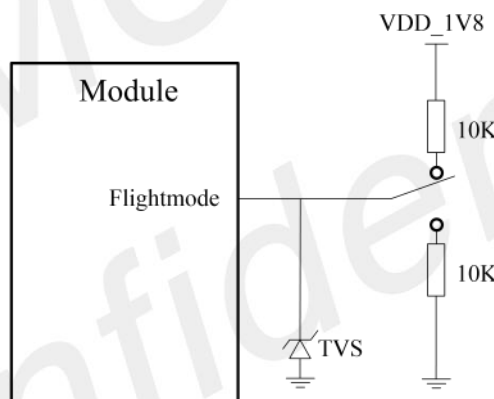

Figure 34: Flight mode switch reference circuit

Table 21: FLIGHTMODE pin status

FLIGHTMODE pin status	Module operation
Input Low Level	Flight Mode: RF is closed
Input High Level	AT+CFUN=0: RF is closed AT+CFUN=1:RF is working

3.13 HSIC Interface

HSIC is a 2-signal source synchronous serial interface which uses 240MHz DDR signaling to provide High-Speed 480Mbps USB transfers which are 100% host driver compatible with traditional USB cable-connected topologies. Full-Speed (FS) and Low-Speed (LS) USB transfers are not directly supported by the HSIC interface (a HSIC enabled hub can provide FS and LS support, as well as IC_USB support) The differences between HSIC and USB2.0 are listed below:

Table 22: Key differences between HSIC and USB

HSIC	USB
Signal-ended signaling at 1.2 V	Differential signaling
Two signals – STROBE, DATA	Four wires – Ground, D+, D-, VBUS
Double data rate signaling	Data inferred from differential signaling
HS-USB 480 Mbps only	HS/FS/LS support
Maximum trace length of 10 cm	Maximum cable length of 5 m
No HS chirp protocol	HS chirp protocol
Lower power consumption (digital)	Higher power consumption (analog)
No concept of disconnect	Hot plug/play support

SIM7600 implements a HSIC interface compliant with the HSIC1.0 specification which can be used to connect to the external IC. And the HSIC could be transferred to USB2.0 by some dedicated Hub Controller, in that case, you could regard SIM7600 as having two USB interfaces.

NOTE

The SIM7600 HSIC can only work as the slave by default, if the host mode is needed, please contact SIMCom for more details.

3.14 GPIO Interface

SIM7600CE WIFI/BT version module provides 2 GPIO for customer use.

The STATUS pin default high for the module status indicate, it is keep high after the module power on, and it can be controlled by the AT commands “AT+CGFUNC” for other use.

Table 23: WIFI/BT Version GPIO

Pin No	PIN Name	GPIO No in AT command	INT	Power Domain	Default status	Default Function	Multiple x Function
49	STATUS	41	✓	P3	B-PU	STATUS	GPIO52
48	GPIO26	44	✓	P3	B-PD	GPIO	SD_DTE

SIM7600CE standard version (without WIFI and BT) module provides 7 GPIO for customer use.

Table 24: Standard version GPIO

Pin No	PIN Name	GPIO No in AT command	INT	Power Domain	Default status	Default Function	Multiple x Function
33	GPIO3	3		-	B-PD	GPIO	
34	GPIO6	6		-	B-PD	GPIO	
48	GPIO26	44	✓	P3	B-PD	GPIO	SD_DTE
49	STATUS	40	✓	P3	B-PU	STATUS	GPIO
50	GPIO43	43		P3	B-PD	GPIO	
52	GPIO41	41	✓	P3	B-PD	GPIO	
87	GPIO77	77		P3	B-PD	GPIO	

3.15 Other Interface

3.15.1 Sink Current Source

The ISINK pin is VBAT tolerant and intended to drive some passive devices, such as LCD backlight and white LED, etc. Its output current can be up to 40mA and be set by the AT command "AT+ CLEDITST".

Table 25: Sink current electronic characteristic

Symbol	Description	Min.	Typ.	Max.	Unit
V_{ISINK}	Voltage tolerant	0.5	-	VBAT	V
I_{ISINK}	Current tolerant	0	-	40	mA

ISINK is a ground-referenced current sink. The following figure shows its reference circuit.

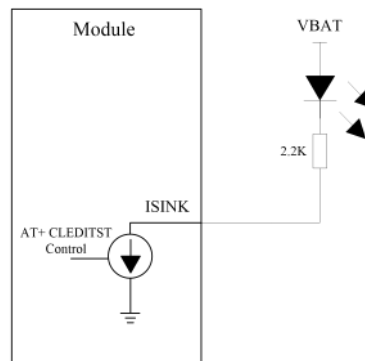

Figure 35: ISINK reference circuit

NOTE

The sinking current can be adjusted to meet the design requirement through the AT command “AT+ CLEDITST =<0>, <value>”. The “value” ranges from 0 to 8, on behalf of the current from 0mA to 40mA by 5mA step.

3.15.2 ADC

Module has 2 dedicated ADC pins named ADC1 and ADC2. They are available for digitizing analog signals such as battery voltage and so on. These electronic specifications are shown in the following table.

Table 26: ADC1 and ADC2 electronic characteristics

Characteristics	Min.	Typ.	Max.	Unit
Resolution	–	15	–	Bits
Conversion time	–	442	–	us
Input Range	0.1		1.7	V
Input serial resistance	1	–	–	MΩ

NOTE

“AT+CADC” and “AT+CADC2” can be used to read the voltage of the ADC1 and ADC2 pins, for more details, please refer to document [1].

3.15.3 LDO

Module has a LDO power output, named VDD_AUX. its output voltage is 2.85V by default, Users can switch the LDO on or off by the AT command “AT+CVAUXS” and configure its output voltage by the AT command “AT+CVAUXV”.

Table 27: Electronic characteristic

Symbol	Description	Min.	Typ.	Max.	Unit
V _{VDD_AUX}	Output voltage	1.7	2.85	3.05	V
I _o	Output current	-	-	150	mA

NOTE

For more details of AT commands about VDD_AUX, please refer to document [1].

SIMCom
Confidential

4 RF Specifications

4.1 GSM/UMTS/LTE RF Specifications

Table 28: Conducted transmission power

Frequency	Power	Min
GSM850	33dBm \pm 2dB	5dBm \pm 5dB
EGSM900	33dBm \pm 2dB	5dBm \pm 5dB
DCS1800	30dBm \pm 2dB	0dBm \pm 5dB
PCS1900	30dBm \pm 2dB	0dBm \pm 5dB
GSM850 (8-PSK)	27dBm \pm 3dB	5dBm \pm 5dB
EGSM900 (8-PSK)	27dBm \pm 3dB	5dBm \pm 5dB
DCS1800 (8-PSK)	26dBm +3/-4dB	0dBm \pm 5dB
PCS1900 (8-PSK)	26dBm +3/-4dB	0dBm \pm 5dB
WCDMA B1	24dBm +1/-3dB	<-50dBm
WCDMA B2	24dBm +1/-3dB	<-50dBm
WCDMA B5	24dBm +1/-3dB	<-50dBm
WCDMA B8	24dBm + 1/-3dB	<-50dBm
LTE-FDD B1	23dBm +/-2.7dB	<-40dBm
LTE-FDD B3	23dBm +/-2.7dB	<-40dBm
LTE-FDD B4	23dBm +/-2.7dB	<-40dBm
LTE-FDD B5	23dBm +/-2.7dB	<-40dBm
LTE-FDD B7	23dBm +/-2.7dB	<-40dBm
LTE-FDD B8	23dBm +/-2.7dB	<-40dBm
LTE-FDD B12	23dBm +/-2.7dB	<-40dBm
LTE-FDD B13	23dBm +/-2.7dB	<-40dBm
LTE-FDD B18	23dBm +/-2.7dB	<-40dBm
LTE-FDD B19	23dBm +/-2.7dB	<-40dBm
LTE-FDD B20	23dBm +/-2.7dB	<-40dBm
LTE-FDD B26	23dBm +/-2.7dB	<-40dBm
LTE-FDD B28	23dBm +/-2.7dB	<-40dBm
LTE-TDD B38	23dBm +/-2.7dB	<-40dBm
LTE-TDD B40	23dBm +/-2.7dB	<-40dBm
LTE-TDD B41	23dBm +/-2.7dB	<-40dBm

Table 29: Operating frequencies

Frequency	Receiving	Transmission
GSM850	869 ~ 894MHz	824 ~ 849 MHz
EGSM900	925 ~ 960MHz	880 ~ 915 MHz
DCS1800	1805 ~ 1880 MHz	1710 ~ 1785 MHz
PCS1900	1930~1990 MHz	1850~1910 MHz
WCDMA B1	2110 ~ 2170 MHz	1920 ~ 1980 MHz
WCDMA B2	1930~1990 MHz	1850~1910 MHz
WCDMA B5	869 ~ 894 MHz	824 ~ 849 MHz
WCDMA B8	925 ~ 960 MHz	880 ~ 915 MHz

The LTE Operating frequencies are shown in the following table 24.
 Note: Operating frequencies of LTE TDD B41 for the module is 100MHz BW, 2555 ~ 2655 MHz

GPS	1574.4 ~ 1576.44 MHz	-
GLONASS	1598 ~ 1606 MHz	-
BD	1559 ~ 1563 MHz	-

Table 30: E-UTRA operating bands

E-UTRA Band	Uplink (UL)	Downlink (DL)
LTE-FDD B1	1920 ~1980 MHz	2110 ~2170 MHz
LTE-FDD B2	1850~1910 MHz	1930~1990 MHz
LTE-FDD B3	1710 ~1785 MHz	1805 ~1880 MHz
LTE-FDD B4	1710~1755MHz	2110~2155MHz
LTE-FDD B5	824 ~ 849 MHz	869 ~ 894MHz
LTE-FDD B7	2500~2570MHz	2620~2690MHz
LTE-FDD B8	880 ~915 MHz	925 ~960 MHz
LTE-FDD B12	699~716MHz	728~746MHz
LTE-FDD B13	777~787MHz	746~757MHz
LTE-FDD B18	815~830MHz	860~875MHz
LTE-FDD B19	830~845MHz	875~890MHz
LTE-FDD B20	832~862MHz	791~ 821MHz
LTE-FDD B26	814~849MHz	859~894MHz
LTE-FDD B28	703~748MHz	758~803MHz
LTE-TDD B38	2570 ~2620 MHz	2570 ~2620 MHz
LTE-TDD B40	2300 ~2400 MHz	2300 ~2400 MHz
LTE-TDD B41	2496 ~2690 MHz	2496 ~2690 MHz

Table 31: Conducted receive sensitivity

Frequency	Receive sensitivity (Typical)	Receive sensitivity (MAX)
GSM850	< -109dBm	3GPP
EGSM900	< -109dBm	3GPP
DCS1800	< -109dBm	3GPP
PCS1900	< -109dBm	3GPP
WCDMA B1	< -110dBm	3GPP
WCDMA B2	< -110dBm	3GPP
WCDMA B5	< -110dBm	3GPP
WCDMA B8	< -110dBm	3GPP
LTE FDD/TDD	See table 26.	3GPP

Table 32: Reference sensitivity (QPSK)

E-UTRA band	Standard						Test Value @10 MHz
	1.4 MHz	3 MHz	5 MHz	10 MHz	15 MHz	20 MHz	
LTE-FDD B1	-	-	-100	-97	-95.2	-94	-101
LTE-FDD B2	-102.7	-99.7	-98	-95	-93.2	-92	-99
LTE-FDD B3	-101.7	-98.7	-97	-94	-92.2	-91	-99
LTE-FDD B4	-104.7	-101.7	-100	-97	-95.2	-94	-101
LTE-FDD B5	-103.2	-100.2	-98	-95			-99
LTE-FDD B7			-98	-95	-93.2	-92	-97
LTE-FDD B8	-102.2	-99.2	-97	-94			-102
LTE-FDD B12	-101.7	-98.7	-97	-94			-99
LTE-FDD B13			-97	-94			-99
LTE-FDD B18			-100	-97	-95.2		-101
LTE-FDD B19			-100	-97	-95.2		-101
LTE-FDD B20			-97	-94	-91.2	-90	-98
LTE-FDD B26	-102.7	-99.7	-97.5	-94.5	-92.7		-99
LTE-FDD B28		-100.2	-98.5	-95.5	-93.7	-91	-99
LTE-TDD B38	-	-	-100	-97	-95.2	-94	-101
LTE-TDD B40	-	-	-100	-97	-95.2	-94	-101
LTE-TDD B41	-	-	-99	-96	-94.2	-93	-101

4.2 GSM /UMTS/LTE Antenna Design Guide

Users should connect antennas to module's antenna pads through micro-strip line or other types of RF trace and the trace impedance must be controlled in 50Ω . SIMCom recommends that the total insertion loss between the antenna pads and antennas should meet the following requirements:

Table 33: Trace loss

Frequency	Loss
700MHz-960MHz	<0.5dB
1710MHz-2170MHz	<0.9dB
2300MHz-2650MHz	<1.2dB

To facilitate the antenna tuning and certification test, a RF connector and an antenna matching circuit should be added. The following figure is the recommended circuit.

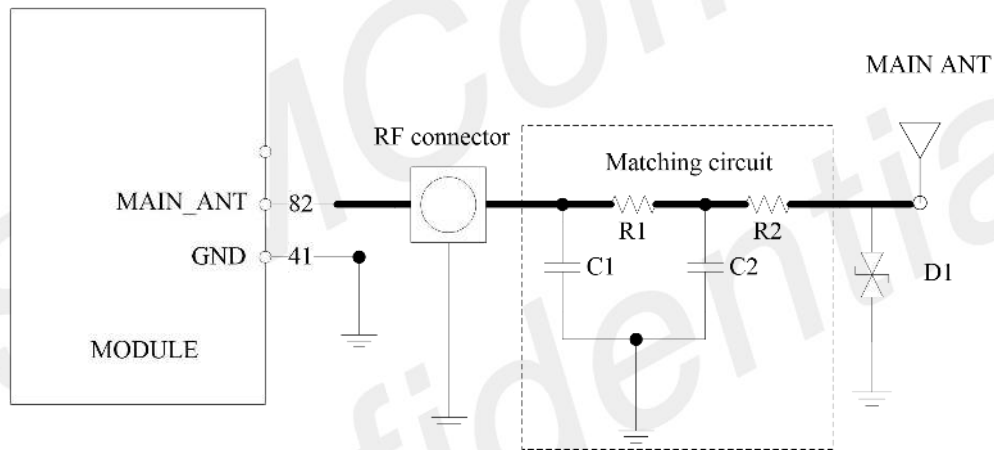

Figure 36: Antenna matching circuit (MAIN_ANT)

In above figure, the components R1, C1, C2 and R2 are used for antenna matching, the values of components can only be achieved after the antenna tuning and usually provided by antenna vendor. By default, the R1, R2 are 0Ω resistors, and the C1, C2 are reserved for tuning. The component D1 is a TVS for ESD protection, and it is optional for users according to application environment.

The RF test connector is used for the conducted RF performance test, and should be placed as close as to the module's MAIN_ANT pin. The traces impedance between module and antenna must be controlled in 50Ω .

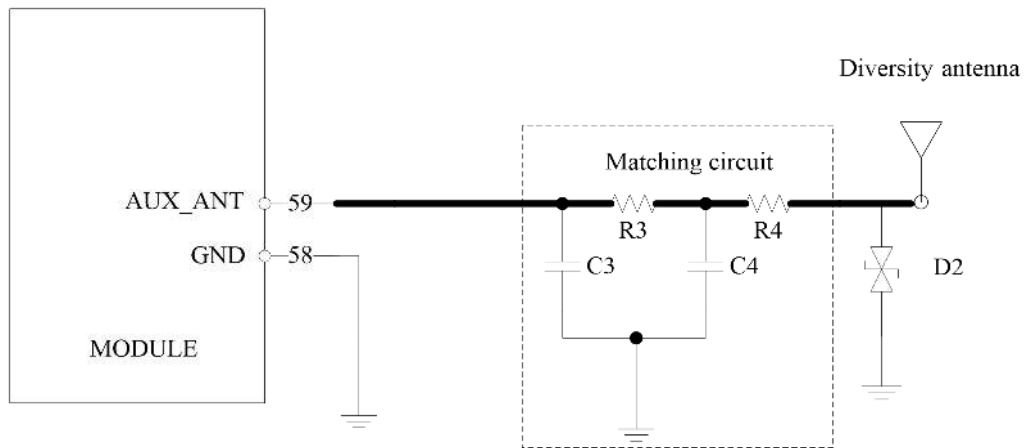

Figure 37: Antenna matching circuit (AUX_ANT)

In above figure, R3, C3, C4 and R4 are used for auxiliary antenna matching. By default, the R3, R4 are 0Ω resistors, and the C3, C4 are reserved for tuning. D2 is a TVS for ESD protection, and it is optional for users according to application environment.

Two TVS are recommended in the table below.

Table 34: Recommended TVS

Package	Part Number	Vender
0201	WE05DGCMS-BH	CYGWAYON
0402	PESD0402-03	PRISEMI
0402	PESD0402-12	PRISEMI

NOTE

SIMCom suggests the LTE auxiliary antenna to be kept on, since there are many high bands in the designing of LTE-TDD, such as band38, band40 and band41. Because of the high insert loss of the RF cable and layout lines, the receiver sensitivity of these bands above will have risk to meet the authentication without the diversity antenna. For more details about auxiliary antenna design notice, please refer to document [25].

4.3 GNSS

Module merges GNSS (GPS/GLONASS/BD/QZSS GALILEO) satellite and network information to provide a high-availability solution that offers industry-leading accuracy and performance. This solution performs well, even in very challenging environmental conditions where conventional GNSS receivers fail, and provides a platform to enable wireless operators to address both location-based services and emergency mandates.

4.3.1 GNSS Technical specification

- Tracking sensitivity: -159 dBm (GPS) /-158 dBm (GLONASS) /-159 dBm (BD) /-159 dBm (GALILEO)
- Cold-start sensitivity: -148 dBm
- Accuracy (Open Sky): 2.5m (CEP50)

- TTFF (Open Sky): Hot start <1s, Cold start<35s
- Receiver Type: 16-channel, C/A Code
- GPS L1 Frequency: 1575.42±1.023MHz
- GLONASS: 1597.5~1605.8 MHz
- BD: 1559.05~1563.14 MHz
- GALILEO: 1575.42±1.023MHz
- Update rate: Default 1 Hz
- GNSS data format: NMEA-0183
- GNSS Current consumption: 100mA (GSM/UMTS/LTE Sleep ,in total on VBAT pins)
- GNSS antenna: Passive/Active antenna

Table 35: Recommended Passive Antenna Characteristics

Passive	Recommended standard
Direction	Omnidirectional
Gain	>-3dBi (Avg)
Input impedance	50 ohm
Efficiency	>50%
VSWR	<2

NOTE

If the antenna is active type, the power should be given by main board because there is no power supply on the GPS antenna pad. If the antenna is passive, it is suggested that the external LNA should be used.

4.3.2 GNSS Application Guide

Users can adopt an active antenna or a passive antenna to module. If using a passive antenna, an external LNA is a must to get better performance.

The following figures are the reference circuits.

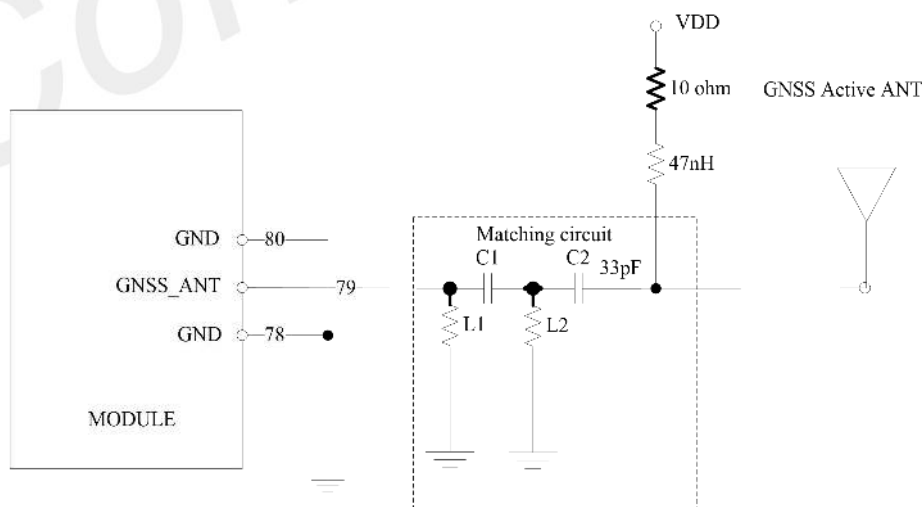

Figure 38: Active antenna circuit

NOTE

If customer need save the power when the GNSS function is disabled, then customer should design a switch circuit to cut off the active antenna power to get a lower power consumption.

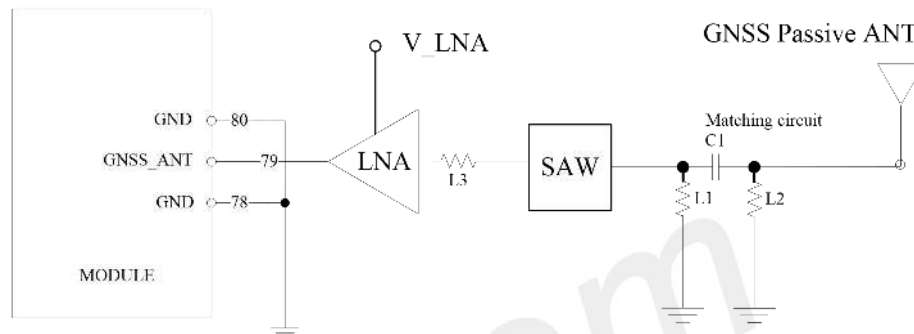

Figure 39: Passive antenna circuit (Default)

In above figures, the components C1, L1 and L2 are used for antenna matching. Usually, the values of the components can only be achieved after antenna tuning and usually provided by antenna vendor. C2 is used for DC blocking. L3 is the matching component of the external LNA, and the value of L3 is determined by the LNA characteristic and PCB layout. Both VDD of active antenna and V_LNA need external power supplies which should be considered according to active antenna and LNA characteristic. LDO/DCDC is recommended to get lower current consuming by shutting down active antennas and LNA when GNSS is not working.

Table 36: Recommended LNA and SAW Filter

Material	Part Number	Vendor
GPS LNA	MXDLN16TP	MAXSCEND
GPS LNA	BGA725L6	Infineon
GPS LNA	BGA824N6	Infineon
GPS SAW FILTER	HDF1588E-B5	SHOULDER
GPS SAW FILTER	SAFFB1G56KB0F0A	murata

GNSS can be tested by NMEA port. NMEA sentences can be obtained through UART or USB automatically. NMEA sentences include GSV, GGA, RMC, GSA, and VTG. Before using GNSS, user should configure module in proper operating mode by AT command. Please refer to related documents for details. module can also get position location information through AT directly.

NOTE

GNSS is closed by default and can be started by AT+CGPS. The AT command has two parameters, the first is on/off, and the second is GNSS mode. Default mode is standalone mode.

AGPS mode needs more support from the mobile telecommunication network. Please refer to document [24] for more details.

5 Electrical Specifications

5.1 Absolute maximum ratings

Absolute maximum rating for digital and analog pins of module are listed in the following table.

Table 37: Absolute maximum ratings

Parameter	Min.	Typ.	Max.	Unit
Voltage at VBAT	-0.5	-	4.7	V
Voltage at USB_VBUS	-0.5	-	5.5	V
Voltage at digital pins (RESET, SPI, Keypad, GPIO, I2C, UART, PCM)	-0.3	-	2.1	V
Voltage at digital pins (SD, USIM)	-0.3	-	3.05	V
Voltage at PWRKEY	-0.3	-	1.8	V

5.2 Operating conditions

Table 38: Recommended operating ratings

Parameter	Min.	Typ.	Max.	Unit
Voltage at VBAT	3.4	3.8	4.2	V
Voltage at USB_VBUS	3.0	5.0	5.25	V

Table 39: 1.8V Digital I/O characteristics*

Parameter	Description	Min.	Typ.	Max.	Unit
V _{IH}	High-level input voltage	1.17	1.8	2.1	V
V _{IL}	Low-level input voltage	-0.3	0	0.63	V
V _{OH}	High-level output voltage	1.35	-	1.8	V
V _{OL}	Low-level output voltage	0	-	0.45	V
I _{OH}	High-level output current (no pull-down resistor)	-	2	-	mA
I _{OL}	Low-level output current (no pull up resistor)	-	-2	-	mA
I _{IH}	Input high leakage current (no pull-down resistor)	-	-	1	uA
I _{IL}	Input low leakage current (no	-1	-	-	uA

pull up resistor)

NOTE

These parameters are for digital interface pins, such as SPI, GPIOs (NETLIGHT, FLIGHTMODE, STATUS, USIM_DET, SD_DET), SDIO, I2C, UART, PCM, COEXn, and USB_BOOT.

The operating temperature of module is listed in the following table.

Table 40: Operating temperature

Parameter	Min.	Typ.	Max.	Unit
Normal operation temperature	-30	25	80	°C
Extended operation temperature*	-40	25	85	°C
Storage temperature	-45	25	+90	°C

NOTE

Module is able to make and receive voice calls, data calls, SMS and make GSM/ UMTX/LTE traffic in -40 °C ~ +85 °C . The performance will be reduced slightly from the 3GPP specifications if the temperature is outside the normal operating temperature range and still within the extreme operating temperature range.

5.3 Operating Mode

5.3.1 Operating Mode Definition

The table below summarizes the various operating modes of module product.

Table 41: Operating mode Definition

Mode	Function
GSM /UMTS/LTE Sleep	In this case, the current consumption of module will be reduced to the minimal level and the module can still receive paging message, call, SMS and TCP/UDP.
GSM/UMTS/LTE Idle	Software is active. Module is registered to the network, and the module is ready to communicate.
GSM/UMTS/LTE Talk	Connection between two subscribers is in progress. In this case, the power consumption depends on network settings such as DTX off/on, FR/EFR/HR, hopping sequences, and antenna.
GPRS/EDGE/ UMTS/LTE Standby	Module is ready for data transmission, but no data is currently sent or received. In this case, power consumption depends on network settings.

GPRS/EDGE/ UMTS/LTE Data transmission	There is data transmission in progress. In this case, power consumption is related to network settings (e.g. power control level); uplink/downlink data rates, etc.
Minimum functionality mode	AT command “AT+CFUN=0” AT+CSCLK=1 can be used to set the module to a minimum functionality mode without removing the power supply. In this mode, the RF part of the module will not work and the USIM card will not be accessible, but the serial port and USB port are still accessible. The power consumption in this mode is lower than normal mode.
Flight mode	AT command “AT+CFUN=4” or pulling down the FLIGHTMODE pin can be used to set the module to flight mode without removing the power supply. In this mode, the RF part of the module will not work, but the serial port and USB port are still accessible. The power consumption in this mode is lower than normal mode.
Power off	Module will go into power off mode by sending the AT command “AT+CPOF” or pull down the PWRKEY pin, normally. In this mode the power management unit shuts down the power supply, and software is not active. The serial port and USB are is not accessible.

5.3.2 Sleep mode

In sleep mode, the current consumption of module will be reduced to the minimal level, and module can still receive paging message and SMS and TCP/UDP.

Several hardware and software conditions must be satisfied together in order to let module enter into sleep mode:

- UART condition
- USB condition
- Software condition

NOTE

Before designing, pay attention to how to realize sleeping/waking function and refer to Document [26] for more details.

5.3.3 Minimum functionality mode and Flight mode

Minimum functionality mode ceases a majority function of module, thus minimizing the power consumption. This mode is set by the AT command which provides a choice of the functionality levels.

- AT+CFUN=0: Minimum functionality
- AT+CFUN=1: Full functionality (Default)
- AT+CFUN=4: Flight mode

If module has been set to minimum functionality mode, the RF function and USIM card function will be closed. In this case, the serial port and USB are still accessible, but RF function and USIM card will be

unavailable.

If module has been set to flight mode, the RF function will be closed. In this case, the serial port and USB are still accessible, but RF function will be unavailable.

When module is in minimum functionality or flight mode, it can return to full functionality by the AT command "AT+CFUN=1".

5.4 Current Consumption

The current consumption is listed in the table below.

Table 42: Current consumption on VBAT Pins (VBAT=3.8V)

GNSS	
GNSS supply current (AT+CFUN=0, without USB connection)	@ -140dBm, Tracking Typical: 35mA
GSM sleep/idle mode	
GSM/GPRS supply current (GNSS off, without USB connection)	Sleep mode@ BS_PA_MFRMS=2 Typical: 2.8mA Idle mode@ BS_PA_MFRMS=2 Typical: 18mA
UMTS sleep/idle mode	
WCDMA supply current (GNSS off, without USB connection)	Sleep mode @DRX=9 Typical: 3.3mA Idle mode @DRX=9 Typical: 17.5mA
LTE sleep/idle mode	
LTE supply current (GNSS off, without USB connection)	Sleep mode Typical: 2.3mA Idle mode Typical: 17.5mA
EVDO supply current (GNSS off, without USB connection)	Sleep mode Typical: 2.0mA Idle mode Typical: 17.8mA
GSM Talk	
GSM850	@power level #5 Typical: 220mA
EGSM900	@ power level #5 Typical: 230mA
DCS1800	@power level #5 Typical: 162mA
PCS1900	@power level #5 Typical: 190mA
UMTS Talk	
WCDMA B1	@Power 24dBm Typical: 540mA
WCDMA B2	@Power 24dBm Typical: 470mA
WCDMA B5	@Power 24dBm Typical: 530mA
WCDMA B8	@Power 24dBm Typical: 385mA
GPRS	
GSM850(1 Rx, 4 Tx)	@power level #5 Typical: 480mA
EGSM900(1 Rx, 4 Tx)	@power level #5 Typical: 230mA
DCS1800(1 Rx, 4 Tx)	@power level #0 Typical: 195mA
PCS1900(1 Rx, 4 Tx)	@power level #0 Typical: 390mA
GSM850(3Rx, 2 Tx)	@power level #5 Typical: 330mA
EGSM900(3Rx, 2 Tx)	@power level #5 Typical: 370mA
DCS1800(3Rx, 2 Tx)	@power level #0 Typical: 275mA

PCS1900(3Rx, 2 Tx) @power level #0 Typical: 245mA

EDGE

GSM850(1 Rx,4 Tx) @power level #8 Typical: 340mA

EGSM900(1 Rx,4 Tx) @power level #8 Typical: 400mA

DCS1800(1 Rx,4 Tx) @power level #2 Typical: 300mA

PCS1900(1 Rx,4 Tx) @power level #2 Typical: 330mA

GSM850(3Rx, 2 Tx) @power level #8 Typical: 280mA

EGSM900(3Rx, 2 Tx) @power level #8 Typical: 320mA

DCS1800(3Rx, 2 Tx) @power level #2 Typical: 230mA

PCS1900(3Rx, 2 Tx) @power level #2 Typical: 268mA

GSM850(1 Rx,4 Tx)

EGSM900(1 Rx,4 Tx) @power level #8 Typical: 400mA

DCS1800(1 Rx,4 Tx) @power level #2 Typical: 300mA

HSDPA data

WCDMA B1 @Power 24dBm Typical: 478mA

WCDMA B2 @Power 23dBm Typical: 475mA

WCDMA B5 @Power 24dBm Typical: 480mA

WCDMA B8 @Power 24dBm Typical: 430mA

LTE data

LTE-FDD B1 @5MHz 22.3dBm Typical: 577mA
@10MHz 22.4dBm Typical: 590mA
@20MHz 22.4dBm Typical: 630mA

LTE-FDD B2 @5MHz 22.1dBm Typical: 515mA
@10MHz 22.4dBm Typical: 544mA
@20MHz 22.3dBm Typical: 575mA

LTE-FDD B3 @5MHz 22.2dBm Typical: 479mA
@10MHz 22.1dBm Typical: 498mA
@20MHz 22.1dBm Typical: 530mA

LTE-FDD B4 @5MHz 22.0dBm Typical: 527mA
@10MHz 22.1dBm Typical: 559mA
@20MHz 22.6dBm Typical: 555mA

LTE-FDD B5 @5MHz 22.2dBm Typical: 610mA
@10MHz 22.1dBm Typical: 600mA
@20MHz 22.1dBm Typical: 630mA

LTE-FDD B7 @5MHz 22.2dBm Typical: 650mA
@10MHz 22.1dBm Typical: 650mA
@20MHz 22.1dBm Typical: 630mA

LTE-FDD B8 @5MHz 22.8dBm Typical: 644mA
@10MHz 22.8dBm Typical: 646mA

LTE-FDD B12 @5MHz 22.7dBm Typical: 493mA
@10MHz 22.7dBm Typical: 510mA

LTE-FDD B13 @5MHz 21.9dBm Typical: 505mA
@10MHz 22.0dBm Typical: 497mA

LTE-FDD B18 @5MHz 21.3dBm Typical: 531mA
@10MHz 22.5dBm Typical: 523mA
@15MHz 22.6dBm Typical: 570mA

LTE-FDD B19 @5MHz 22.4dBm Typical: 532mA
@10MHz 22.3dBm Typical: 541mA
@15MHz 22.5dBm Typical: 590mA

LTE-FDD B20 @5MHz 21.8dBm Typical: 579mA
@10MHz 21.8dBm Typical: 590mA

	@20MHz	21.8dBm	Typical: 600mA
LTE-FDD B26	@5MHz	22.4dBm	Typical: 525mA
	@10MHz	22.7dBm	Typical: 570mA
	@15MHz	22.3dBm	Typical: 580mA
LTE-FDD B28	@5MHz	22.4dBm	Typical: 612mA
	@10MHz	22.5dBm	Typical: 510mA
	@20MHz	22.4dBm	Typical: 670mA
LTE-TDD B38	@5MHz	21.8dBm	Typical: 370mA
	@10MHz	21.8dBm	Typical: 380mA
	@20MHz	21.8dBm	Typical: 403mA
LTE-TDD B40	@5MHz	21.5dBm	Typical: 407mA
	@10MHz	21.7dBm	Typical: 416mA
	@20MHz	21.7dBm	Typical: 444mA
LTE-TDD B41	@5MHz	21.6dBm	Typical: 390mA
	@10MHz	21.7dBm	Typical: 396mA
	@20MHz	21.7dBm	Typical: 420mA

5.5 ESD Notes

Module is sensitive to ESD in the process of storage, transporting, and assembling. When module is mounted on the users' mother board, the ESD components should be placed beside the connectors which human body may touch, such as USIM card holder, audio jacks, switches, keys, etc. The following table shows the module ESD measurement performance without any external ESD component.

Table 43: The ESD performance measurement table (Temperature: 25°C, Humidity: 45%)

Part	Contact discharge	Air discharge	Part
VBAT, GND	+/-4K	+/-8K	VBAT, GND
Antenna port	+/-4K	+/-8K	Antenna port
USB	+/-1K	+/-2K	USB
UART	+/-1K	+/-2K	UART
Other PADS	+/-1K	+/-2K	Other PADS

6 SMT Production Guide

6.1 Top and Bottom View of Module



Figure 40: Top and bottom view of module

6.2 Label Information



Figure 41: Label information

Table 44: The description of label information

No.	Description
A	LOGO
B	Module part number
C	Project name
D	Serial number
E	International mobile equipment identity
F	QR code

6.3 Typical SMT Reflow Profile

SIMCom provides a typical soldering profile. Therefore, the soldering profile shown below is only a generic recommendation and should be adjusted to the specific application and manufacturing constraints.

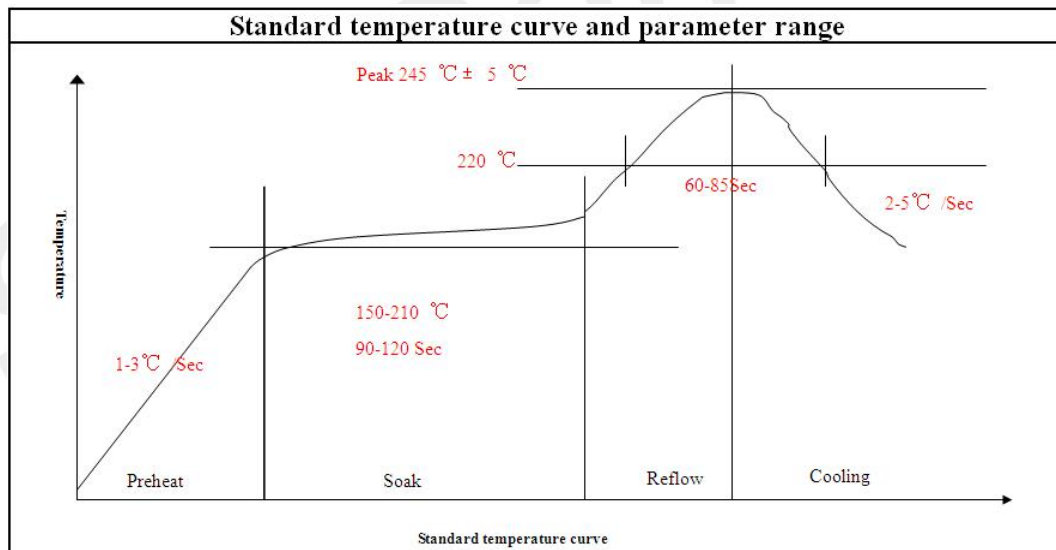

Figure 42: The ramp-soak-spike reflow profile of module

NOTE

For more details about secondary SMT, please refer to the document [21].

6.4 Moisture Sensitivity Level (MSL)

Module is qualified to Moisture Sensitivity Level (MSL) 3 in accordance with JEDEC J-STD-033. If the prescribed time limit is exceeded, users should bake module for 192 hours in drying equipment (<5% RH) at 40+5/-0°C, or 8 hours at 120+5/-5°C. Note that plastic tray is not heat-resistant, and only can be baked at 45° C.

Table 45: Moisture Sensitivity Level and Floor Life

Moisture Sensitivity Level (MSL)	Floor Life (out of bag) at factory ambient $\leq 30^{\circ}\text{C}/60\% \text{ RH}$ or as stated
1	Unlimited at $\leq 30^{\circ}\text{C}/85\% \text{ RH}$
2	1 year
2a	4 weeks
3	168 hours
4	72 hours
5	48 hours
5a	24 hours
6	Mandatory bake before use. After bake, it must be reflowed within the time limit specified on the label.

NOTE

IPC / JEDEC J-STD-033 standard must be followed for production and storage.

6.5 Recommend dimensions of SMT stencil

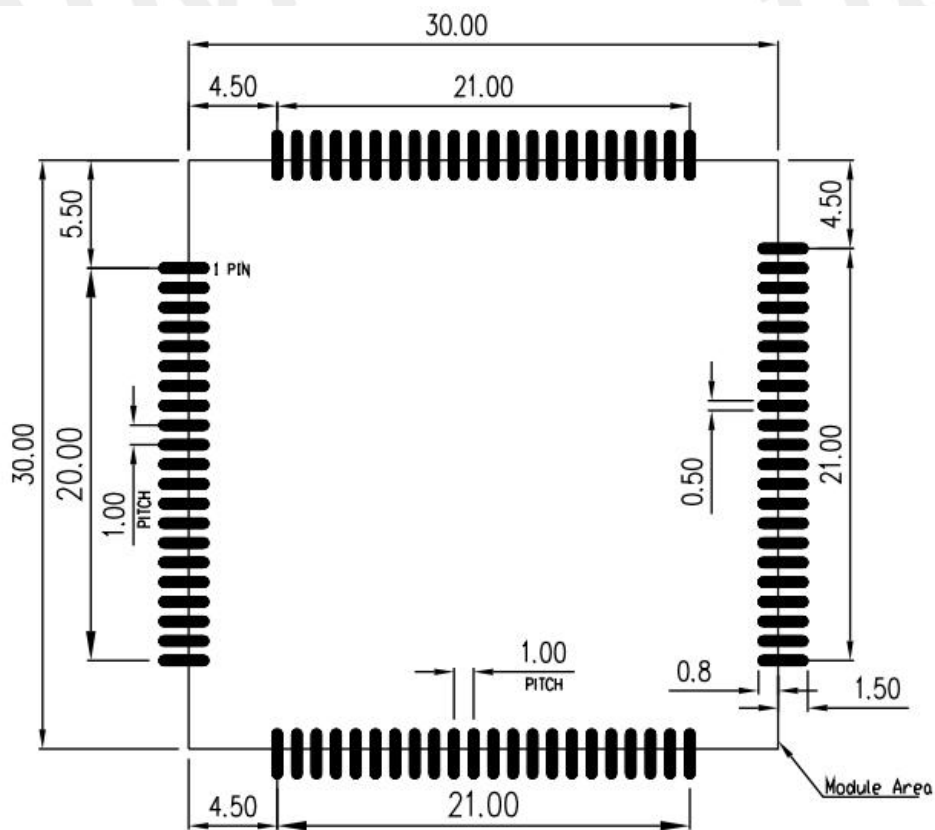

Figure 43: Recommend SMT stencil

6.6 Stencil Foil Design Recommendation

The recommended thickness of stencil foil is more than 0.15mm.

SIMCom
Confidential

7 Packaging

Module support tray packaging.

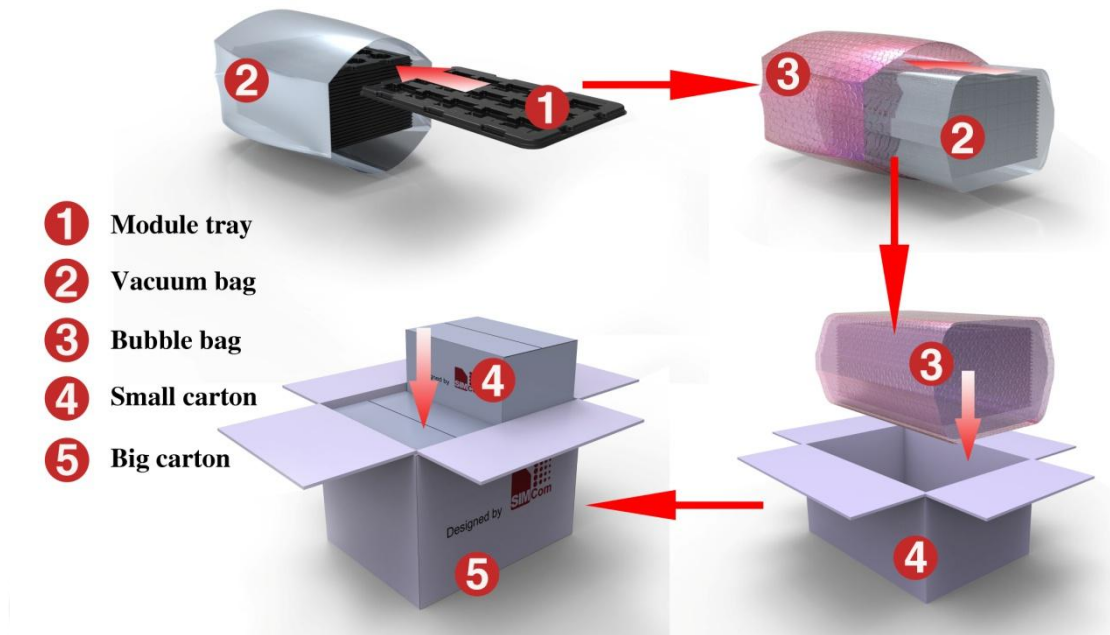

Figure 44: packaging diagram

Module tray drawing:

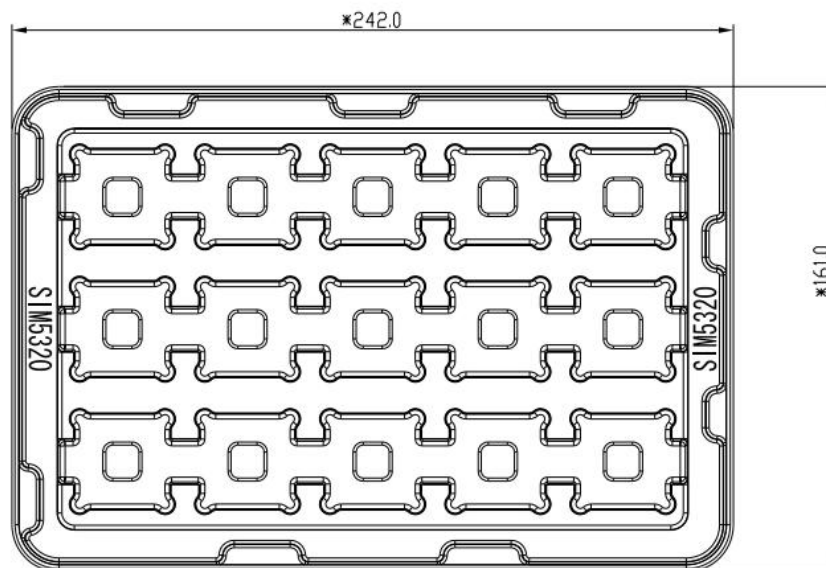

Figure 45: Tray drawing

Table 46: Tray size

Length ($\pm 3\text{mm}$)	Width ($\pm 3\text{mm}$)	Number
242.0	161.0	15

Small carton drawing:

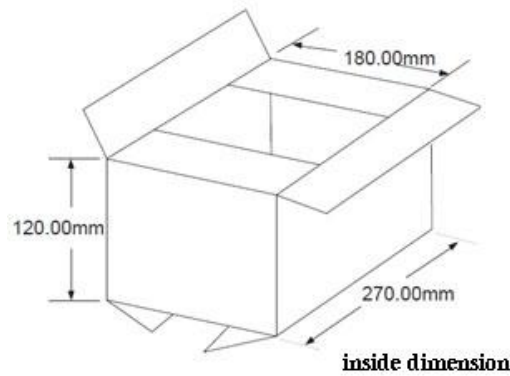

Figure 46: Small carton drawing

Table 47: Small Carton size

Length ($\pm 10\text{mm}$)	Width ($\pm 10\text{mm}$)	Height ($\pm 10\text{mm}$)	Number
270	180	120	15*20=300

Big carton drawing:

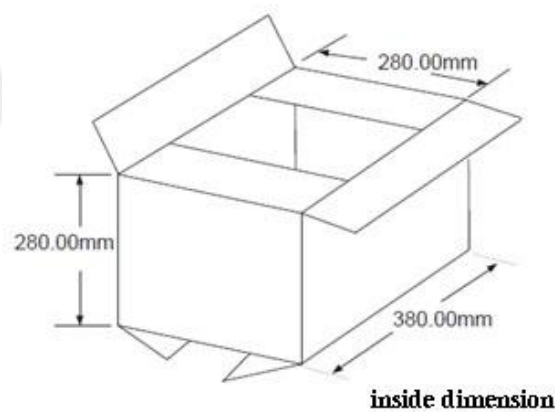

Figure 47: Big carton drawing

Table 48: Big Carton size

Length ($\pm 10\text{mm}$)	Width ($\pm 10\text{mm}$)	Height ($\pm 10\text{mm}$)	Number
380	280	280	300*4=1200

8 Appendix

8.1 Reference Design

Refer to < SIM7600 Reference Design V1.X.pdf > for the details.

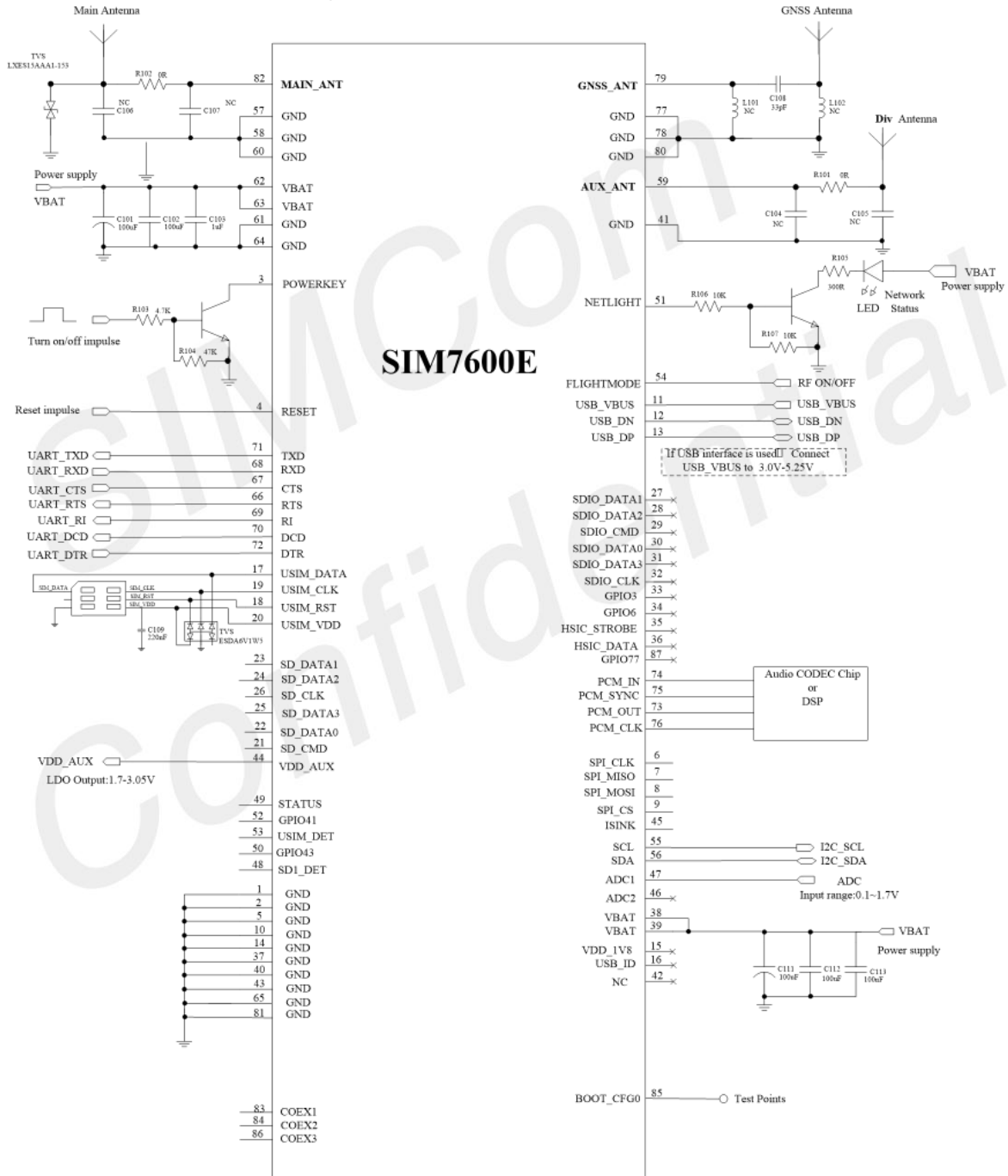

Figure 48: Reference design

8.2 Coding Schemes and Maximum Net Data Rates over Air Interface

Table 49: Coding Schemes and Maximum Net Data Rates over Air Interface

Multislot definition(GPRS/EDGE)				
Slot class	DL slot number	UL slot number	Active number	slot
1	1	1	2	
2	2	1	3	
3	2	2	3	
4	3	1	4	
5	2	2	4	
6	3	2	4	
7	3	3	4	
8	4	1	5	
9	3	2	5	
10	4	2	5	
11	4	3	5	
12	4	4	5	
GPRS coding scheme		Max data rata (4 slots)	Modulation type	
CS 1 = 9.05 kb/s / time slot		36.2 kb/s	GMSK	
CS 2 = 13.4 kb/s / time slot		53.6 kb/s	GMSK	
CS 3 = 15.6 kb/s / time slot		62.4 kb/s	GMSK	
CS 4 = 21.4 kb/s / time slot		85.6 kb/s	GMSK	
EDGE coding scheme		Max data rata (4 slots)	Modulation type	
MCS 1 = 8.8 kb/s/ time slot		35.2 kb/s	GMSK	
MCS 2 = 11.2 kb/s/ time slot		44.8 kb/s	GMSK	
MCS 3 = 14.8 kb/s/ time slot		59.2 kb/s	GMSK	
MCS 4 = 17.6 kb/s/ time slot		70.4 kb/s	GMSK	
MCS 5 = 22.4 kb/s/ time slot		89.6 kb/s	8PSK	
MCS 6 = 29.6 kb/s/ time slot		118.4 kb/s	8PSK	
MCS 7 = 44.8 kb/s/ time slot		179.2 kb/s	8PSK	
MCS 8 = 54.4 kb/s/ time slot		217.6 kb/s	8PSK	
MCS 9 = 59.2 kb/s/ time slot		236.8 kb/s	8PSK	
HSDPA device category		Max data rate (peak)	Modulation type	
Category 1		1.2Mbps	16QAM,QPSK	
Category 2		1.2Mbps	16QAM,QPSK	
Category 3		1.8Mbps	16QAM,QPSK	
Category 4		1.8Mbps	16QAM,QPSK	
Category 5		3.6Mbps	16QAM,QPSK	
Category 6		3.6Mbps	16QAM,QPSK	

Category 7	7.2Mbps	16QAM,QPSK
Category 8	7.2Mbps	16QAM,QPSK
Category 9	10.2Mbps	16QAM,QPSK
Category 10	14.4Mbps	16QAM,QPSK
Category 11	0.9Mbps	QPSK
Category 12	1.8Mbps	QPSK
Category 13	17.6Mbps	64QAM
Category 14	21.1Mbps	64QAM
Category 15	23.4Mbps	16QAM
Category 16	28Mbps	16QAM
Category 17	23.4Mbps	64QAM
Category 18	28Mbps	64QAM
Category 19	35.5Mbps	64QAM
Category 20	42Mbps	64QAM
Category 21	23.4Mbps	16QAM
Category 22	28Mbps	16QAM
Category 23	35.5Mbps	64QAM
Category 24	42.2Mbps	64QAM
HSUPA device category	Max data rate (peak)	Modulation type
Category 1	0.96Mbps	QPSK
Category 2	1.92Mbps	QPSK
Category 3	1.92Mbps	QPSK
Category 4	3.84Mbps	QPSK
Category 5	3.84Mbps	QPSK
Category 6	5.76Mbps	QPSK
LTE-FDD device category (Downlink)	Max data rate (peak)	Modulation type
Category 1	10Mbps	QPSK/16QAM/64QAM
Category 2	50Mbps	QPSK/16QAM/64QAM
Category 3	100Mbps	QPSK/16QAM/64QAM
Category 4	150Mbps	QPSK/16QAM/64QAM
LTE-FDD device category (Uplink)	Max data rate (peak)	Modulation type
Category 1	5Mbps	QPSK/16QAM
Category 2	25Mbps	QPSK/16QAM
Category 3	50Mbps	QPSK/16QAM
Category 4	50Mbps	QPSK/16QAM

8.3 Related Documents

Table 50: Related Documents

NO	Title	Description
[1]	SIM7500_SIM7600 Series_AT Command Manual_V1.xx	AT Command Manual
[2]	ITU-T Draft new recommendation V.25ter	Serial asynchronous automatic dialing and control
[3]	GSM 07.07	Digital cellular telecommunications (Phase 2+); AT command set for GSM Mobile Equipment (ME)
[4]	GSM 07.10	Support GSM 07.10 multiplexing protocol
[5]	GSM 07.05	Digital cellular telecommunications (Phase 2+); Use of Data Terminal Equipment – Data Circuit terminating Equipment (DTE – DCE) interface for Short Message Service (SMS) and Cell Broadcast Service (CBS)
[6]	GSM 11.14	Digital cellular telecommunications system (Phase 2+); Specification of the SIM Application Toolkit for the Subscriber Identity Module – Mobile Equipment (SIM – ME) interface
[7]	GSM 11.11	Digital cellular telecommunications system (Phase 2+); Specification of the Subscriber Identity Module – Mobile Equipment (SIM – ME) interface
[8]	GSM 03.38	Digital cellular telecommunications system (Phase 2+); Alphabets and language-specific information
[9]	GSM 11.10	Digital cellular telecommunications system (Phase 2) ; Mobile Station (MS) conformance specification ; Part 1: Conformance specification
[10]	3GPP TS 51.010-1	Digital cellular telecommunications system (Release 5); Mobile Station (MS) conformance specification
[11]	3GPP TS 34.124	Electromagnetic Compatibility (EMC) for mobile terminals and ancillary equipment.
[12]	3GPP TS 34.121	Electromagnetic Compatibility (EMC) for mobile terminals and ancillary equipment.
[13]	3GPP TS 34.123-1	Technical Specification Group Radio Access Network; Terminal conformance specification; Radio transmission and reception (FDD)
[14]	3GPP TS 34.123-3	User Equipment (UE) conformance specification; Part 3: Abstract Test Suites.
[15]	EN 301 908-02 V2.2.1	Electromagnetic compatibility and Radio spectrum Matters (ERM); Base Stations (BS) and User Equipment (UE) for IMT-2000. Third Generation cellular networks; Part 2: Harmonized EN for IMT-2000, CDMA Direct Spread (UTRA FDD) (UE) covering essential requirements of article 3.2 of the R&TTE Directive
[16]	EN 301 489-24 V1.2.1	Electromagnetic compatibility and Radio Spectrum Matters (ERM); Electromagnetic Compatibility (EMC) standard for radio equipment and services; Part 24: Specific conditions for

		IMT-2000 CDMA Direct Spread (UTRA) for Mobile and portable (UE) radio and ancillary equipment
[17]	IEC/EN60950-1(2001)	Safety of information technology equipment (2000)
[18]	3GPP TS 51.010-1	Digital cellular telecommunications system (Release 5); Mobile Station (MS) conformance specification
[19]	GCF-CC V3.23.1	Global Certification Forum - Certification Criteria
[20]	2002/95/EC	Directive of the European Parliament and of the Council of 27 January 2003 on the restriction of the use of certain hazardous substances in electrical and electronic equipment (RoHS)
[21]	Module secondary-SMT-UGD-V1.xx	Module secondary SMT Guidelines
[22]	SIM7X00 Series_UART_Application Note_V1.xx	This document describes how to use UART interface of SIMCom modules.
[23]	SIM7100_SIM7500_SIM7600 Series_USB AUDIO_Application Note_V1.xx	USB AUDIO Application Note
[24]	SIM7X00 Series_GPS_Application Note_V1.xx	GPS Application Note
[25]	Antenna design guidelines for diversity receiver system	Antenna design guidelines for diversity receiver system
[26]	SIM7100_SIM7500_SIM7600_Sleep_Mode_Application Note_V1.xx	Sleep Mode Application Note
[27]	7600CE-LAN-Reference Design V1.0	HSIC Application Note

8.4 Terms and Abbreviations







Table 51: Terms and Abbreviations

Abbreviation	Description
ADC	Analog-to-Digital Converter
ARP	Antenna Reference Point
BER	Bit Error Rate
BTS	Base Transceiver Station
CS	Coding Scheme
CSD	Circuit Switched Data
CTS	Clear to Send
DAC	Digital-to-Analog Converter
DRX	Discontinuous Reception
DSP	Digital Signal Processor
DTE	Data Terminal Equipment (typically computer, terminal, printer)
DTR	Data Terminal Ready
DTX	Discontinuous Transmission
EFR	Enhanced Full Rate
EGSM	Enhanced GSM
EMC	Electromagnetic Compatibility
ESD	Electrostatic Discharge
ETS	European Telecommunication Standard
EVDO	Evolution Data Only
FCC	Federal Communications Commission (U.S.)
FD	SIM fix dialing phonebook
FDMA	Frequency Division Multiple Access
FR	Full Rate
GMSK	Gaussian Minimum Shift Keying
GNSS	Global Navigation Satellite System
GPRS	General Packet Radio Service
GPS	Global Positioning System
GSM	Global Standard for Mobile Communications
HR	Half Rate
HSPA	High Speed Packet Access
I2C	Inter-Integrated Circuit
IMEI	International Mobile Equipment Identity
LTE	Long Term Evolution
MO	Mobile Originated
MS	Mobile Station (GSM engine), also referred to as TE
MT	Mobile Terminated

NMEA	National Marine Electronics Association
PAP	Password Authentication Protocol
PBCCH	Packet Switched Broadcast Control Channel
PCB	Printed Circuit Board
PCS	Personal Communication System, also referred to as GSM 1900
RF	Radio Frequency
RMS	Root Mean Square (value)
RTC	Real Time Clock
SIM	Subscriber Identification Module
SMS	Short Message Service
SPI	serial peripheral interface
SMPS	Switched-mode power supply
TDMA	Time Division Multiple Access
TE	Terminal Equipment, also referred to as DTE
TX	Transmit Direction
UART	Universal Asynchronous Receiver & Transmitter
VSWR	Voltage Standing Wave Ratio
SM	SIM phonebook
NC	Not connect
EDGE	Enhanced data rates for GSM evolution
HSDPA	High Speed Downlink Packet Access
HSUPA	High Speed Uplink Packet Access
ZIF	Zero intermediate frequency
WCDMA	Wideband Code Division Multiple Access
VCTCXO	Voltage control temperature-compensated crystal oscillator
USIM	Universal subscriber identity module
UMTS	Universal mobile telecommunications system

8.5 Safety Caution

Table 52: Safety Caution

Marks	Requirements
	<p>When in a hospital or other health care facility, observe the restrictions about the use of mobiles. Switch the cellular terminal or mobile off, medical equipment may be sensitive and not operate normally due to RF energy interference.</p>
	<p>Switch off the cellular terminal or mobile before boarding an aircraft. Make sure it is switched off. The operation of wireless appliances in an aircraft is forbidden to prevent interference with communication systems. Forgetting to think much of these instructions may impact the flight safety, or offend local legal action, or both.</p>
	<p>Do not operate the cellular terminal or mobile in the presence of flammable gases or fumes. Switch off the cellular terminal when you are near petrol stations, fuel depots, chemical plants or where blasting operations are in progress. Operation of any electrical equipment in potentially explosive atmospheres can constitute a safety hazard.</p>
	<p>Your cellular terminal or mobile receives and transmits radio frequency energy while switched on. RF interference can occur if it is used close to TV sets, radios, computers or other electric equipment.</p>
	<p>Road safety comes first! Do not use a hand-held cellular terminal or mobile when driving a vehicle, unless it is securely mounted in a holder for hands free operation. Before making a call with a hand-held terminal or mobile, park the vehicle.</p>
	<p>GSM cellular terminals or mobiles operate over radio frequency signals and cellular networks and cannot be guaranteed to connect in all conditions, especially with a mobile fee or an invalid SIM card. While you are in this condition and need emergent help, please remember to use emergency calls. In order to make or receive calls, the cellular terminal or mobile must be switched on and in a service area with adequate cellular signal strength. Some networks do not allow for emergency call if certain network services or phone features are in use (e.g. lock functions, fixed dialing etc.). You may have to deactivate those features before you can make an emergency call. Also, some networks require that a valid SIM card be properly inserted in the cellular terminal or mobile.</p>