



PCA9616

3-channel multipoint Fast-mode Plus differential I²C-bus buffer with hot-swap logic

Rev. 2 — 10 March 2014

Product data sheet

1. General description

The PCA9616 is a Fast-mode Plus (Fm+) SMBus/I²C-bus buffer that extends the normal single-ended SMBus/I²C-bus through electrically noisy environments using a differential SMBus/I²C-bus (dI²C) physical layer, which is transparent to the SMBus/I²C-bus protocol layer. It consists of three single-ended to differential driver channels for the SCL (serial clock), SDA (serial data), and a third channel useful for INT or other signaling.

Remark: If the third channel is not used, the INT pin (pin 7 of the TSSOP16 package) should not be left disconnected or 'floating' (it may generate incorrect bus signals due to system noise entering this high-impedance node). Tie it to V_{SS}.

The use of differential transmission lines between identical dI²C bus buffers removes electrical noise and common-mode offsets that are present when signal lines must pass between different voltage domains, are bundled with hostile signals, or run adjacent to electrical noise sources, such as high energy power supplies and electric motors.

The SMBus/I²C-bus was conceived as a simple slow speed digital link for short runs, typically on a single PCB or between adjacent PCBs with a common ground connection. Applications that extend the bus length or run long cables require careful design to preserve noise margin and reject interference.

The dI²C-bus buffers were designed to solve these problems and are ideally suited for rugged high noise environments and/or longer cable applications, allow multiple slaves, and operate at bus speeds up to 1 MHz clock rate. Cables can be extended to at least three meters (3 m), or longer cable runs at lower clock speeds. The dI²C-bus buffers are compatible with existing SMBus/I²C-bus devices and can drive Standard, Fast-mode, and Fast-mode Plus devices on the single-ended side.

Signal direction is automatic, and requires no external control. To prevent bus latch up, the standard SMBus/I²C-bus side of the bus buffer, the PCA9616 employs static offset, care should be taken when connecting these to other SMBus/I²C-bus buffers that may not operate with offset.

This device is a bridge between the normal 2-wire single-ended wired-OR SMBus/I²C-bus and the 4-wire dI²C-bus.

Additional circuitry allows the PCA9616 to be used for 'hot swap' applications, where systems are always on, but require insertion or removal of modules or cards without disruption to existing signals.

The PCA9616 has two supply voltages, V_{DD(A)} and V_{DD(B)}. V_{DD(A)}, the card side supply, only serves as a reference and ranges from 0.8 V to 5.5 V. V_{DD(B)}, the line side supply, serves as the majority supply for circuitry and ranges from 3.0 V to 5.5 V.



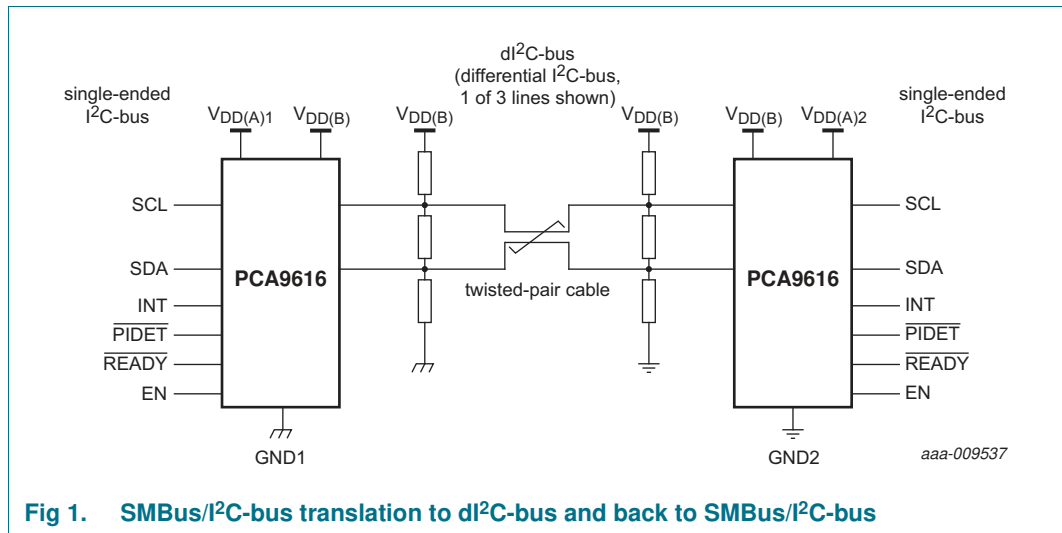

2. Features and benefits

- New dI²C-bus buffers offer improved resistance to system noise and ground offset up to 1/2 of supply voltage
- Hot swap (allows insertion or removal of modules or card without disruption to bus data)
- READY signal (PCA9616 output) indicates device is ready from a cold start
- EN signal (PCA9616 input) controls PCA9616 hot swap sequence
- Bus idle detect (PCA9616 internal function) waits for a bus idle condition before connection is made
- 3 channel dI²C (differential I²C-bus) to Fm+ single-ended buffer operating up to 1 MHz with 30 mA SDA/SCL > 2.2 V, or 3 mA SDA/SCL < 2.4 V
- Compatible with I²C-bus Standard/Fast-mode and SMBus, Fast-mode Plus up to 1 MHz
- Active HIGH (internal pull-up resistor) Enable disables the device to high-impedance state
- Single-ended I²C-bus on card side up to 540 pF >2.2 V and 400 pF <2.4 V
- Differential I²C-bus on cable side supporting multi-drop bus
 - ◆ Maximum cable length: 3 m (approximately 10 feet) (longer at lower frequency)
 - ◆ dI²C output: 1.5 V differential output with nominal terminals
 - ◆ Differential line impedance (user defined): 100 Ω nominal suggested
 - ◆ Receive input sensitivity: ±200 mV
 - ◆ Hysteresis: ±30 mV typical
 - ◆ Input impedance: high-impedance (200 kΩ typical)
 - ◆ Receive input voltage range: -0.5 V to +5.5 V
- Lock-up free operation
- Supports arbitration and clock stretching across the dI²C-bus buffers
- Powered-off and powering-up high-impedance I²C-bus pins
- Operating supply voltage (V_{DD(A)}) range of 0.8 V to 5.5 V with single-ended side 5.5 V tolerant

3-channel multipoint Fm+ dI²C-bus buffer with hot-swap logic

- Differential I²C-bus operating supply voltage (V_{DD(B)}) range of 3.0 V to 5.5 V with 5.5 V tolerant. Best operation is at 5 V.
- ESD protection exceeds 2000 V HBM per JESD22-A114 and 1000 V CDM per JESD22-C101
- Latch-up testing is done to JEDEC Standard JESD78 which exceeds 100 mA
- Package offering: TSSOP16

3. Applications

- Any application with multiple power supplies and the potential for ground offsets up to 2.5 V
- Any application that requires long I²C-bus runs in electrically noisy environments
- Monitor remote temperature/leak detectors in harsh environment with interrupt back to master
- Control of power supplies in high noise environment
- Transmission of I²C-bus between equipment cabinets
- Commercial lighting and industrial heating/cooling control

4. Ordering information

Table 1. Ordering information

Type number	Topside marking	Package		
		Name	Description	Version
PCA9616PW	PCA9616	TSSOP16	plastic thin shrink small outline package; 16 leads; body width 4.4 mm	SOT403-1

4.1 Ordering options

Table 2. Ordering options

Type number	Orderable part number	Package	Packing method	Minimum order quantity	Temperature range
PCA9616PW	PCA9616PW,118	TSSOP16	Reel 13" Q1/T1 *standard mark SMD	2500	T _{amb} = -40 °C to +85 °C

5. Block diagram

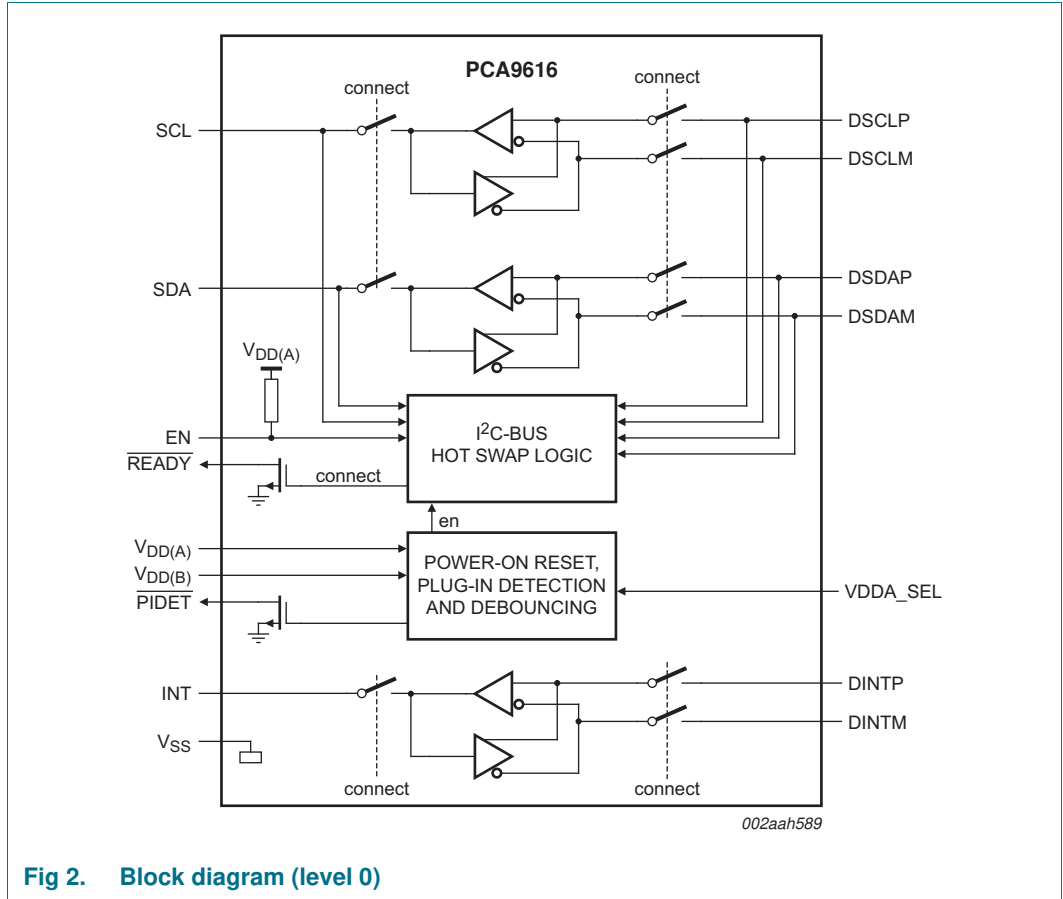

Fig 2. Block diagram (level 0)

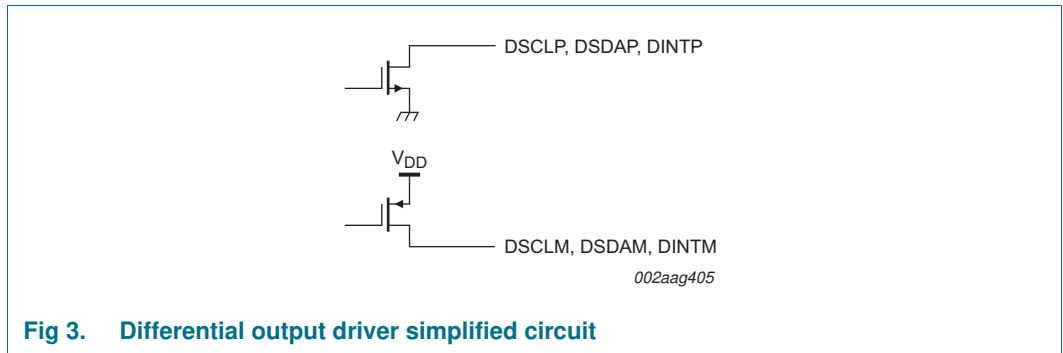

Fig 3. Differential output driver simplified circuit

6. Pinning information

6.1 Pinning

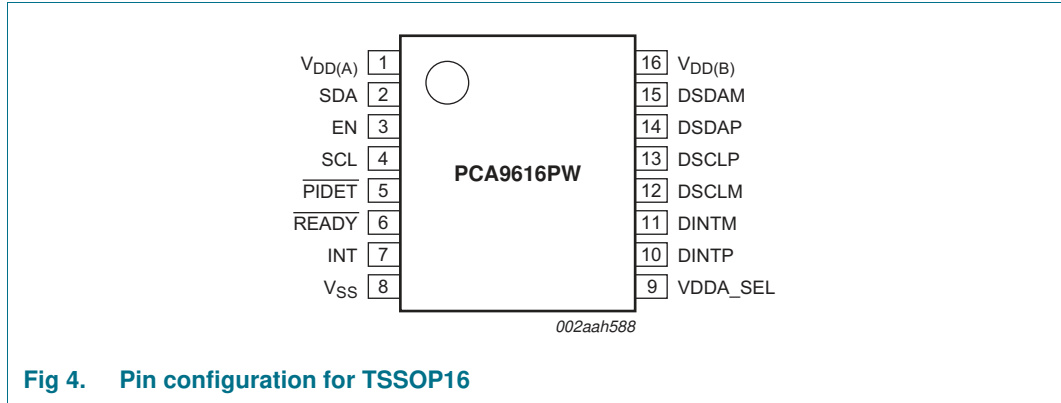

Fig 4. Pin configuration for TSSOP16

6.2 Pin description

Table 3. Pin description

Symbol	Pin	Description
V _{DD(A)}	1	I ² C-bus side power supply (0.8 V to 5.5 V)
SDA	2	card side open-drain serial data input/output
EN	3	enable input (active HIGH); internal pull-up resistor to V _{DD(A)}
SCL	4	card side open-drain serial clock input/output
PIDE̅T	5	plug-in detection, open-drain output LOW to indicate that all hot-swap pins have been steady and reliably plugged into the backplane
REA̅DY	6	open-drain output that goes HIGH when SDA and SCL are disconnected from DSDA and DSCL, and pulls LOW when two sides are connected
INT	7	card side open-drain interrupt input/output
V _{SS}	8	ground supply voltage (0 V)
VDDA_SEL	9	V _{DD(A)} supply pin option input. Floating automatically selects threshold based on V _{DD(A)} magnitude. Recommend to be HIGH when V _{DD(A)} > 2.2 V and be LOW when V _{DD(A)} < 2.4 V through a resistor.
DIN̅TP	10	line side differential open-drain interrupt plus input/output
DIN̅TM	11	line side differential open-drain interrupt minus input/output
DSCL̅M	12	line side differential open-drain clock minus input/output
DSCL̅P	13	line side differential open-drain clock plus input/output
DSDAP	14	line side differential open-drain data plus input/output
DSDAM	15	line side differential open-drain data minus input/output
V _{DD(B)}	16	differential side power supply (3.0 V to 5.5 V)

7. Functional description

Refer to [Figure 2](#).

The PCA9616 is used at each node of the dI²C-bus signal path, to provide conversion from the dI²C-bus signal format to conventional I²C-bus/SMBus, allowing the connection of existing I²C-bus/SMBus devices as slaves or the bus master. Because the signal voltages on the I²C-bus/SMBus bus side may be different from the dI²C-bus side, there are two power supply pins and a common ground. Static offset is employed by the I²C-bus/SMBus side to prevent bus latch up. Signal direction is determined by the I²C-bus/SMBus bus protocol, and does not require a direction signal, as these bus buffers automatically set signal flow direction. An enable pin (EN) is provided to disable the bus buffer, and is useful for fault finding, power-up sequencing, or reconfiguration of a large bus system by isolating sections not needed at all times.

Construction of the differential transmission line is not device dependent. PCB traces, open wiring, twisted pair cables or a combination of these may be used. Twisted pair cables offer the best performance. A typical twisted pair transmission line cable has a characteristic impedance of 'about 100 Ω' and must be terminated at both ends in 100 Ω to prevent unwanted signal reflections. Multiple nodes (each using a dI²C-bus buffer) may be connected at any point along this transmission line, however, the stub length will degrade the bus performance, and should therefore be minimized.

7.1 I²C-bus/SMBus side

The I²C-bus/SMBus side of the PCA9616 differential bus buffer is connected to other I²C-bus/SMBus devices and requires pull-up resistors on each of the SCL and SDA signals. The value of the resistor should be chosen based on the bus capacitance and desired data speed, being careful not to overload the driver current rating of 3 mA for Standard and Fast modes, 30 mA for Fast-mode Plus (Fm+). Note that at lower supply voltages the driver will not deliver the higher current (see [Table 5 "Static characteristics"](#)). The I²C-bus/SMBus side of the PCA9616 is powered from the V_{DD(A)} supply pin.

7.2 dI²C-bus side differential pair

In previous I²C-bus/SMBus designs the nodes (Master and one or more Slaves) are connected by wired-OR in combination with a single pull-up resistor. This simple arrangement is not suited for long distances more than one meter (1 m) or about three feet (3 ft), due to ringing and reflections on the un-terminated bus. The use of a transmission line with correct termination eliminates this problem, and is further improved by differential signaling used in the dI²C-bus scheme. Each node acts as both a driver and a receiver to allow bidirectional signal flow, but not at the same time. Switching from transmit to receive is done automatically. The dI²C-bus side of the PCA9616 is powered from the V_{DD(B)} supply pin.

The dI²C-bus is also biased to an idle state (D+ more positive than D-) to be compatible with the I²C-bus/SMBus wired-OR scheme, when not transmitting traffic (data). This allows every node to receive broadcast messages from the Master, and return ACK/NACK and data in response. Biasing is done with additional resistors, connected to V_{DD(B)} and V_{SS} (the local ground), as shown in [Figure 5](#). The transmission line is terminated in the characteristic impedance of the cable, typically 100 Ω. This is the value defined by three resistors, the other two resistors providing the idle condition bias to the twisted pair.

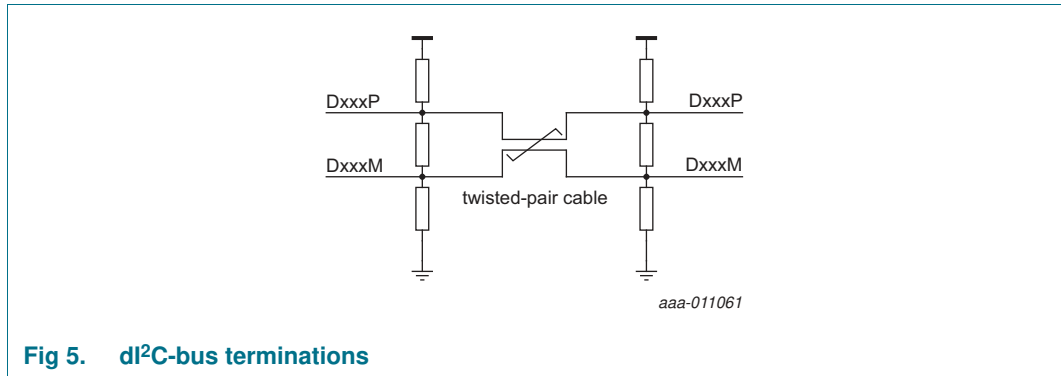

Fig 5. dI²C-bus terminations

7.2.1 Noise rejection

Impulse noise coupled into the I²C-bus/SMBus signals can prevent the I²C-bus/SMBus bus from operating reliably. The hostile signals may appear on the SCL line, SDA line, or both. Impulse noise may also enter the common ground connection, or be caused by current in the ground path caused by DC power supplies, or other signals sharing the common ground return path. This problem is removed by using a differential transmission line, in place of the I²C-bus/SMBus signal path. The dI²C-bus receiver (at each dI²C-bus node) subtracts the signals on the two differential lines (D+ and D-), and eliminates any common-mode noise that is coupled into the dI²C-bus. The receiver amplifies the signals which are also attenuated by the bulk resistance of the transmission line cable connection, and does not rely on a common ground connection at each node.

7.2.2 Rejection of ground offset voltage

Hostile signals interfere with the I²C-bus/SMBus bus through the common ground connection between each node. Current in this ground path will cause an offset that may cause false data or push the I²C-bus/SMBus signals outside of an acceptable range. Unwanted ground offset can be caused by heavy DC current in the ground path, or injection of ground current from AC signals, either of which may show up as false signals.

Because the dI²C-bus node's receiver responds only to the difference between the two dI²C-bus transmission lines, common-mode signals are ignored. There is no need to have a ground connection between each of the nodes, which may be powered locally. Nodes may also be powered by extra conductors (for V_{DD} and ground) run with the dI²C-bus signals. Voltage offsets caused by DC current in these additional wires will be ignored by the dI²C-bus receiver, which subtracts the two differential signals (D+ and D-).

7.2.3 Interrupt channel

The PCA9616 has a third channel identical to the SCL or SDA channel that can be used as a side band for interrupt or reset.

If unused, the INT pin should be held LOW and the DINTM and DINTP are left 'not connected'.

7.3 EN pin

Enable input to connect the device into bus. When this pin is LOW, the device will never connect to the bus, and disconnect the SCL/SDA from differential SCL/SDA, and READY pin set HIGH. When EN is driven HIGH, and $V_{DD(A)}$ and $V_{DD(B)}$ are stable and I²C-bus side are with appropriate loads (indicated by \overline{PIDET} goes LOW), the EN pin connects SDA/SCL to differential SDA/SCL after a stop bit or bus idle has been detected on differential line bus. EN pin should never change state during an I²C-bus/SMBus operation because disabling during a bus operation will hang the bus and enabling part way through a bus cycle could confuse the I²C-bus/SMBus parts being enabled. The EN pin should only change state when the global bus and the buffer port are in an idle state to prevent system failures.

7.4 \overline{PIDET} pin

Plug-in status output. This open-drain N-channel MOSFET output pulls LOW when the hot-swapped pins (differential SDA and SCL) have been steady and reliably plugged into the bus when $V_{DD(A)}$ and $V_{DD(B)}$ are powered. Connect a pull-up resistor, typically 10 k Ω , from this pin to $V_{DD(A)}$. Leave open or tie to V_{SS} if unused.

7.5 \overline{READY} pin

Connection ready status output. This open-drain N-channel MOSFET output goes HIGH when the input and output sides are disconnected. \overline{READY} is pulled LOW when EN is HIGH, \overline{PIDET} is LOW, and a connection has been established between the input and differential output. Connect a pull-up resistor, typically 10 k Ω , from this pin to $V_{DD(A)}$. Leave open or tie to V_{SS} if unused.

7.6 V_{DDA_SEL} pin

Enable input to select $V_{DD(A)}$ range. Tie to $V_{DD(B)}$ if $V_{DD(A)}$ is greater than 2.2 V and constant V_{OL} on SCL/SDA (0.52 V) is desired, and tie to V_{SS} if $V_{DD(A)}$ is less than 2.4 V and the ratio V_{OL} ($0.2 \times V_{DD(A)}$) is desired. Or leave open to let the device automatically switch based on $V_{DD(A)}$ magnitude.

7.7 Hot swap and power-on reset

During a power-on sequence, an initialization circuit holds the PCA9616 in a disconnected state, meaning all outputs — SDA, SCL and the differential pins DSCLP/DSCLM and DSDAP/DSDAM — are in a high-impedance state. As the power supply rises (either power-up or live insertion), the initialization circuit enters a state where the internal references are stabilized and an internal timer is triggered. After 1 ms, power is applied to the rest of the circuitry and the PCA9616 detects the status on the differential DSCLP/DSCLM and DSDAP/DSDAM lines. When the differential lines are detected as connected to a bus with valid termination, that is, both DSCLM/DSDAM $< 0.9 \times V_{DD(B)}$ and DSCLP/DSDAP $> 0.1 \times V_{DD(B)}$, another timer is triggered. At the end of 10 ms, hot-swap logic ([Figure 2](#)) is enabled and the EN pin can detect a Stop Bit and Bus Idle condition. However, there is still no connection between SDA and DSDAP/DSDAM or between SCL and DSCLP/DSCLM. A successful EN pin sequence must occur for actual connection.

When the EN pin is set HIGH and the DSDAP and DSCLP pins have been HIGH for the bus idle time or when both the SCL and SDA pins are HIGH and a STOP condition has been seen on the differential bus (DSDAP/DSDAM and DSCLP/DSCLM pins), a

connection is established between the differential and the single-ended buses. Whenever disconnected status is detected or the device is un-powered, the PCA9616 will disconnect the single-ended to differential buses, and the hot swap sequence will repeat again before the PCA9616 connects SDA to DSDAP/DSDAM and SCL to DSCLP/DSCLM.

Remark: Start-up process is the same for both PCA9616PW and PCA9615DP, except that $\overline{\text{PIDET}}$ and $\overline{\text{READY}}$ signals are only available in 16-pin package.

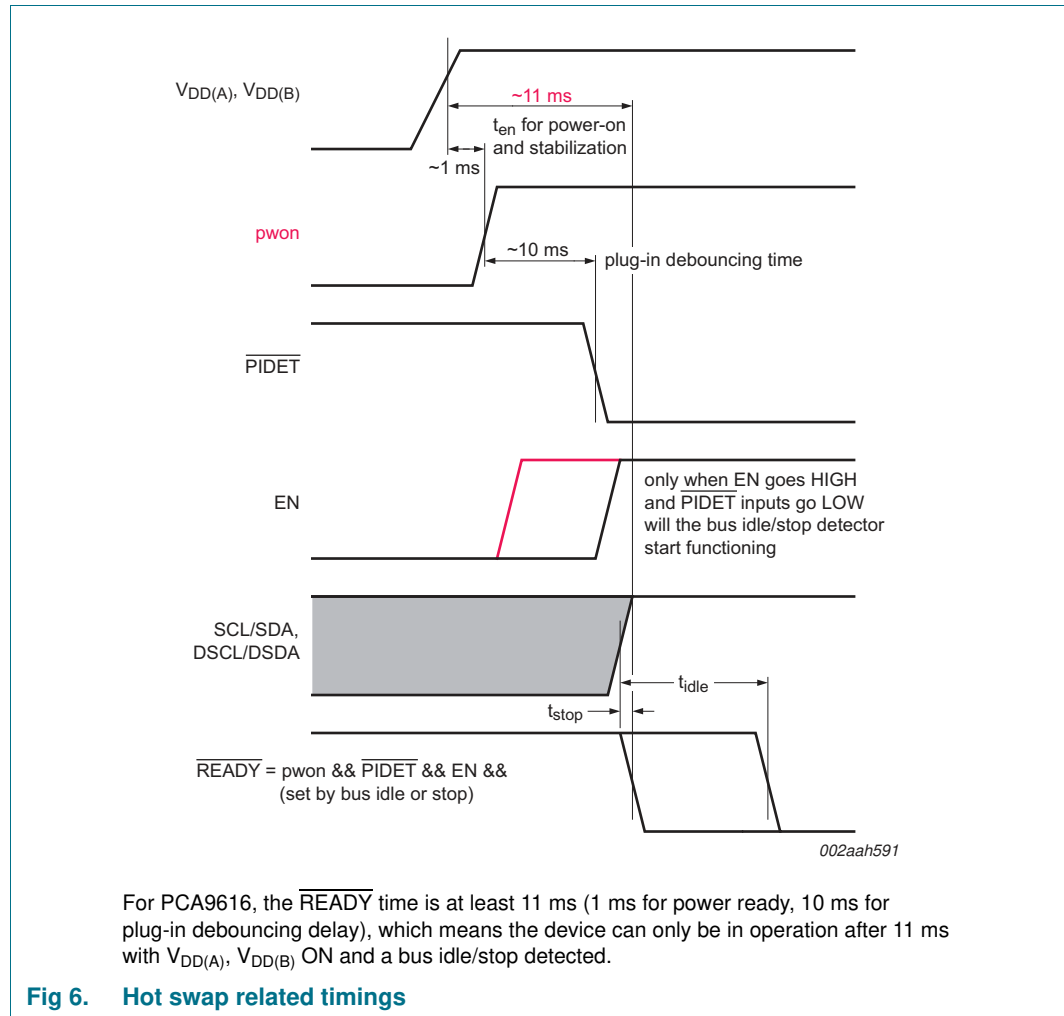

8. Application design-in information

8.1 I²C-bus

As with the standard I²C-bus system, pull-up resistors are required to provide the logic HIGH levels on the single-ended buffered bus (standard open-drain configuration of the I²C-bus). The size of these pull-up resistors depends on the system. The device is designed to work with Standard-mode, Fast-mode and Fast-mode Plus I²C-bus devices in addition to SMBus devices. Standard-mode and Fast-mode I²C-bus and SMBus devices only specify 3 mA output drive; this limits the termination current to 3 mA in a generic I²C-bus system where Standard-mode devices and multiple masters are possible.

When only Fast-mode Plus devices are used, then higher termination currents can be used due to their 30 mA sink capability. The sink capability varies from 3 mA at 0.8 V to 30 mA at 5.5 V with the cut-off between 30 mA and 3 mA at 2.3 V.

8.2 Differential I²C-bus application

See [Figure 7](#) through [Figure 9](#).

The simple application ([Figure 7](#)) shows an existing SMBus/I²C-bus being extended over a section of dI²C-bus transmission line, containing a dedicated twisted pair for SCL and SDA. At one end of the transmission line a resistor network (R1-R2-R1) terminates the twisted pair cable and biases D+ positive with respect to D-. An identical resistor network at the other end of the transmission line terminates the twisted pair cable. DC power for each end of the transmission line and the V_{DD(B)} of each PCA9616 bus buffer can be from separate and isolated power supplies, or use the same supply and ground run in separate wires along the same path as the dI²C-bus signal twisted pairs.

Telecom category 5 ('CAT 5') data cable is well suited for this task, but loose wires may also be used, with a reduction in performance. Assuming V_{DD(B)} is 5 V, and using CAT 5 cable, R2 is 120 Ω, and R1 is 600 Ω. The parallel combination yields a termination of 100 Ω at each end of the twisted pairs.

Either side of the dI²C-bus buffer pair is connected to standard SMBus/I²C buses, which require their own pull-up resistors to V_{DD(A)} of the PCA9616 bus buffers. V_{DD(A)} and V_{DD(B)} can be the same supply, however, making them different voltages enables the PCA9616 bus buffers to level translate between the SMBus/I²C-bus and dI²C-bus sections of the bus, or to have different supply voltages and level translate at either end of the dI²C-bus and SMBus/I²C-bus system.

For example, the left-hand bus master (and local slave) may operate on a 3.3 V supply and SMBus/I²C-bus while the dI²C-bus transmission lines are at 5 V, and the right-hand slave is operated from a different 3.3 V supply and SMBus/I²C-bus, or even a different bus voltage other than 3.3 V.

Depending upon the timing from the system master, clock toggle rates can vary from 10 kHz for the SMBus (or less for SMBus/I²C-bus protocol) up to 100 kHz (Standard mode), 400 kHz (Fast mode), or up to 1 MHz (Fast-mode Plus).

The bus path is bidirectional. Assume that the left side SMBus/I²C-bus becomes active. A START condition (SDA goes LOW while SDA is HIGH) is sent. This upsets the idle condition on the dI²C-bus section of the bus, because D+ was more positive than D- and

now they are reversed. The right side bus buffer sees the differential lines change polarity and in turn pulls SDA LOW on the SMBus/I²C-bus side of the bus buffer, transmitting the START condition to the slave on that section of the SMBus/I²C-bus.

If the data clocked out by the left side master contains a valid address of the right side slave, that slave responds by pulling SDA LOW on the ninth clock. This condition is transmitted across the dI²C-bus section that has now changed flow direction, and received by the left side bus buffer (again, D+ was more positive than D- and now they are reversed).

This sequence continues until the master sends the STOP condition (SCL HIGH while SDA goes HIGH), placing the active slave (on the right side) back to idle. When idle, the normal SMBus/I²C-bus (both left and right sections) are pulled up by their respective pull-ups. In turn, the dI²C-bus section of the bus rests with D+ more positive than D-.

The idle condition can be changed by any node on either SMBus/I²C-bus section or an additional dI²C-bus node, if present, on the dI²C-bus section of the system. This allows the existing SMBus/I²C-bus protocol to operate transparently over a mix of SMBus/I²C and dI²C bus segments.

Due to the SMBus/I²C-bus handshake protocol (ACK/NACK on the ninth clock pulse), the direction of the SMBus/I²C-bus is reversed often. The 'time of flight' for the signals to pass through each bus buffer and for the target slave to respond defines the maximum speed of the bus, regardless of how fast the clock toggles. The dI²C-bus section of the bus requires two additional PCA9616 bus buffers, further delaying the SMBus/I²C-bus traffic. If the dI²C-bus transmission line section is made longer, the bus will operate much slower, regardless of the clock toggle speed.

It is not necessary to have a ground connection between each end of the dI²C section of the bus. The dI²C-bus receiver responds to reversal of the polarity of the D+ and D- signals, and ignores the common-mode voltage that may be present.

Ideally, the common-mode voltage is the same at each end of the twisted pairs, and no current flows along the twisted pair when the bus is idle, because the D+ and D- dI²C-bus drivers are both high-impedance, the bus is biased by R1-R2-R1 at each end. If the common-mode voltage is not 0 V, current will flow along the twisted pair, returning through the common ground or common power supply connection if present.

If both ends of the twisted pair are powered by the same $V_{DD(B)}$ supply and one end is remote, there will be a common-mode offset between them. This is ignored by the dI²C-bus receivers, which only respond to the difference between D+ and D-.

However, a large common-mode offset voltage will force the D+ and D- signals out of the range of the receiver, and data will be lost. The PCA9616 bus buffers use standard ESD protection networks to protect the external pins, and therefore should not be biased above or below the $V_{DD(B)}$ and V_{SS} pins respectively. This limits the common-mode range to approximately $0.5 \times V_{DD(B)}$.

DC resistance of the transmission line will attenuate the signals, more so over longer distances. The loss of signal amplitude is made up by the gain of the dI²C-bus receiver. There is a limit to how long the dI²C-bus section can be made, as it is necessary for the driver to overcome the bias on the transmission line, in order to signal a polarity change (D+ and D- reversal) at the receiver end.

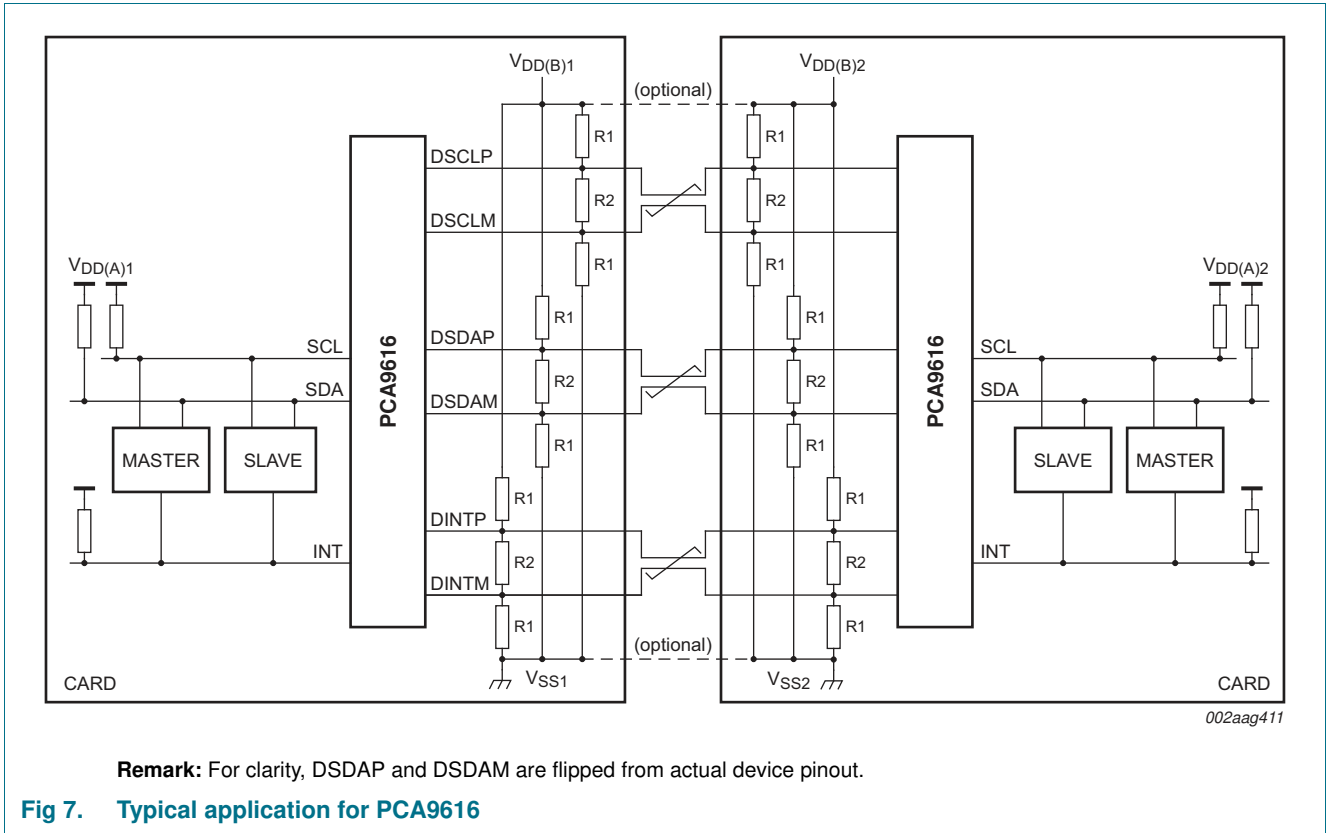

002aag411

3-channel multipoint Fm+ dI²C-bus buffer with hot-swap logic

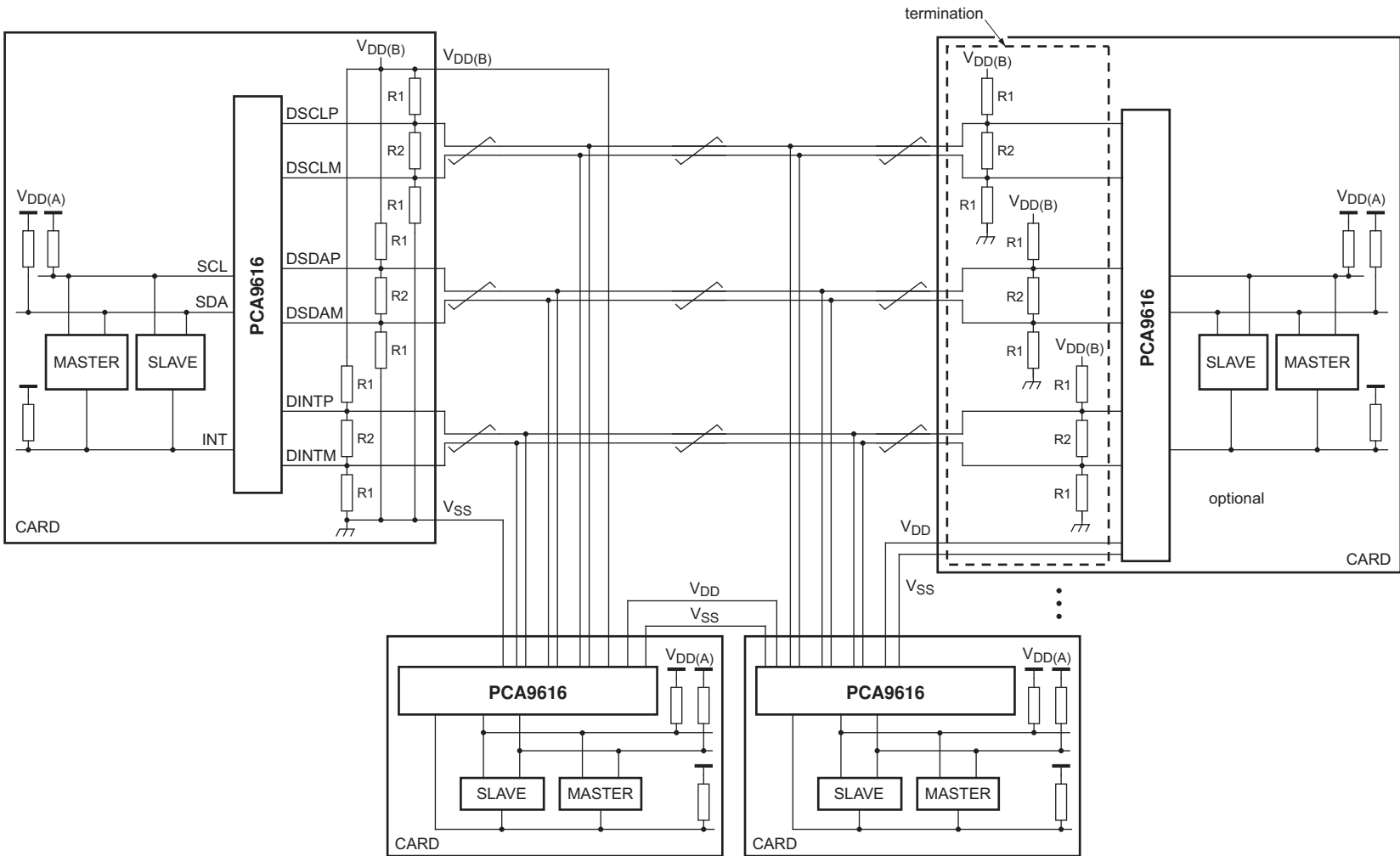

002aag412

Remark: For clarity, DSDAP and DSDAM are flipped from actual device pinout.

Fig 8. PCA9616 application diagram; V_{DD} and V_{SS} are routed through the cable

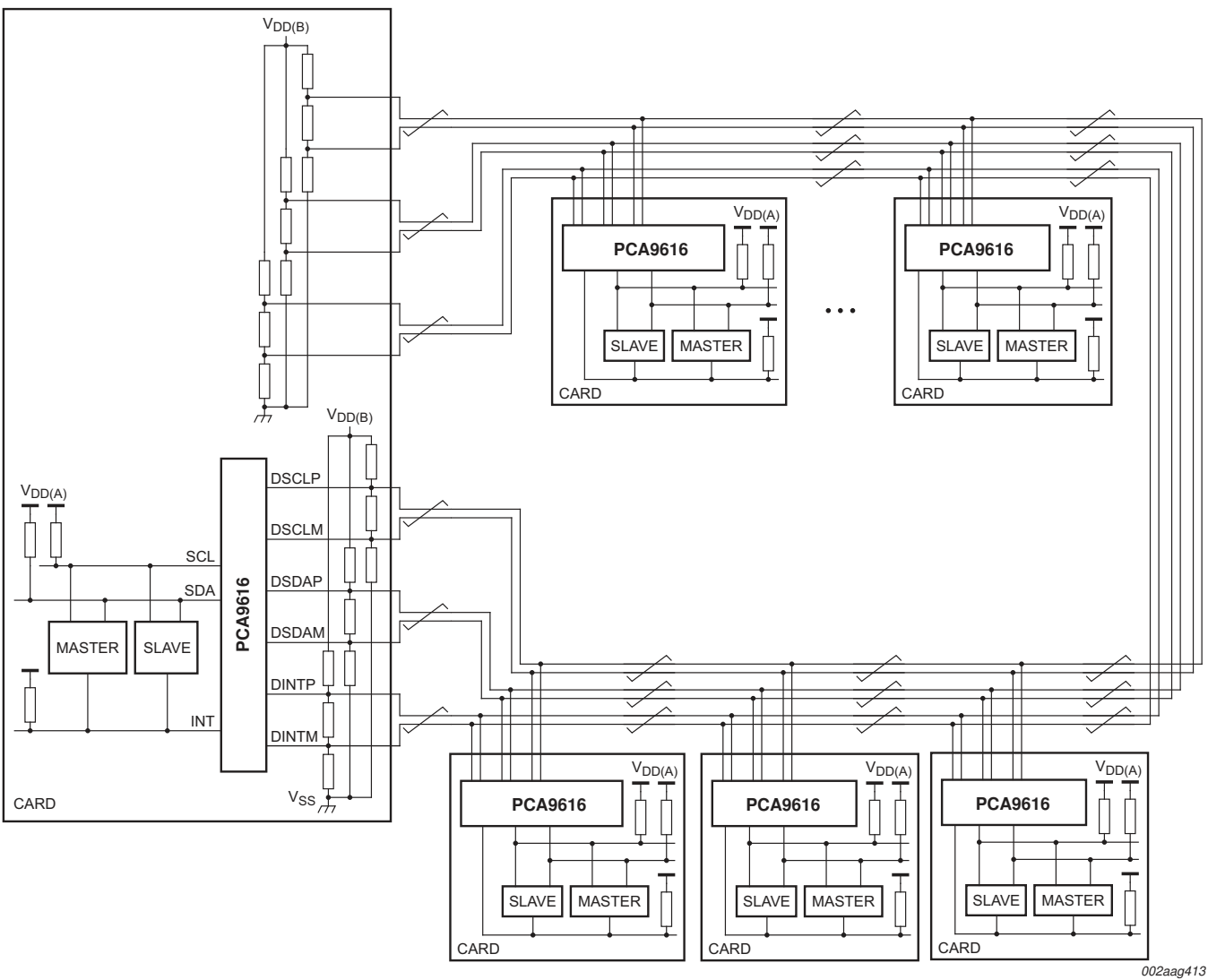

Remark: For clarity, DSDAP and DSDAM are flipped from actual device pinout.

Fig 9. PCA9616 application diagram; V_{DD} and V_{SS} are not routed through the cable

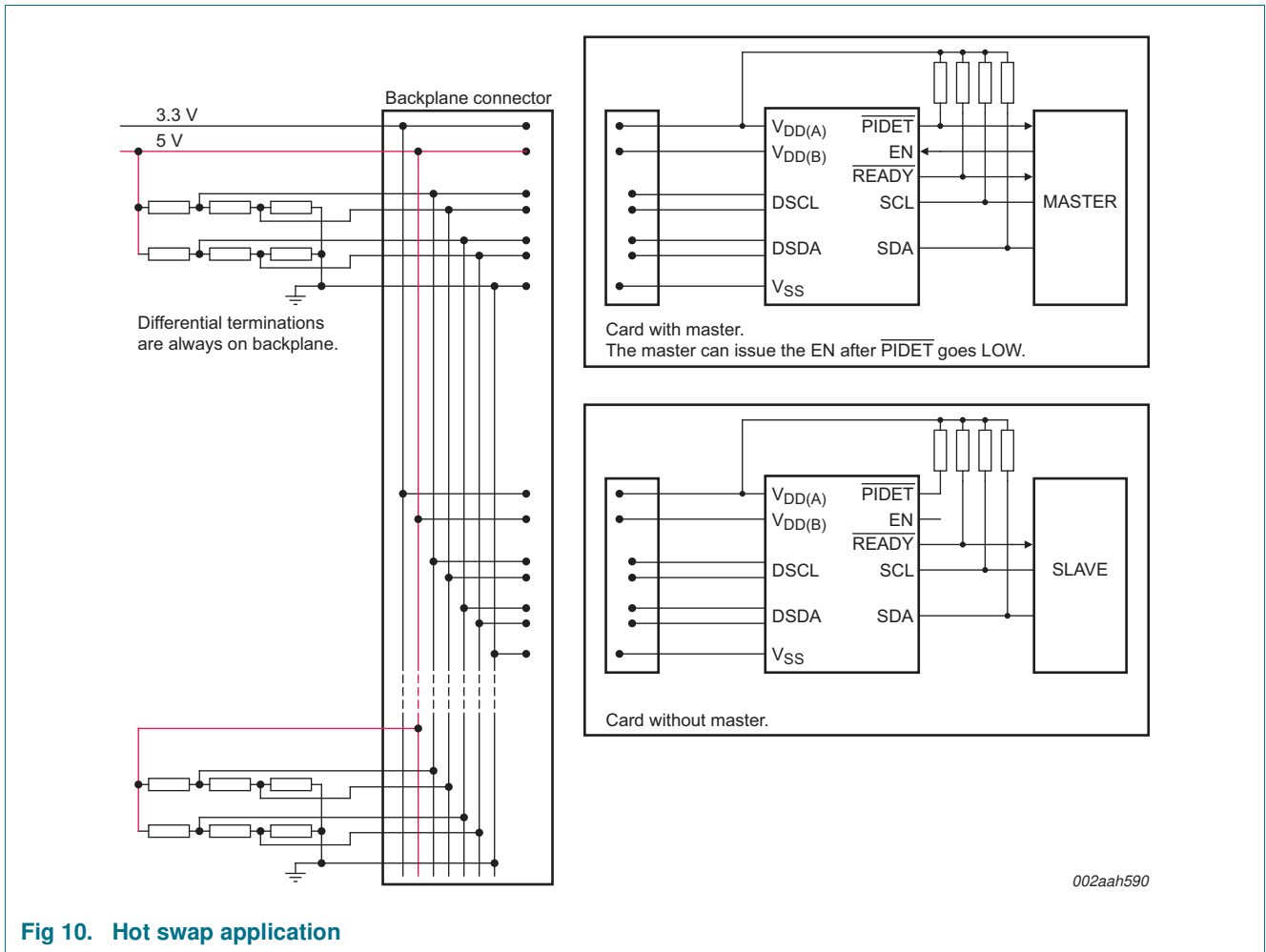

Fig 10. Hot swap application

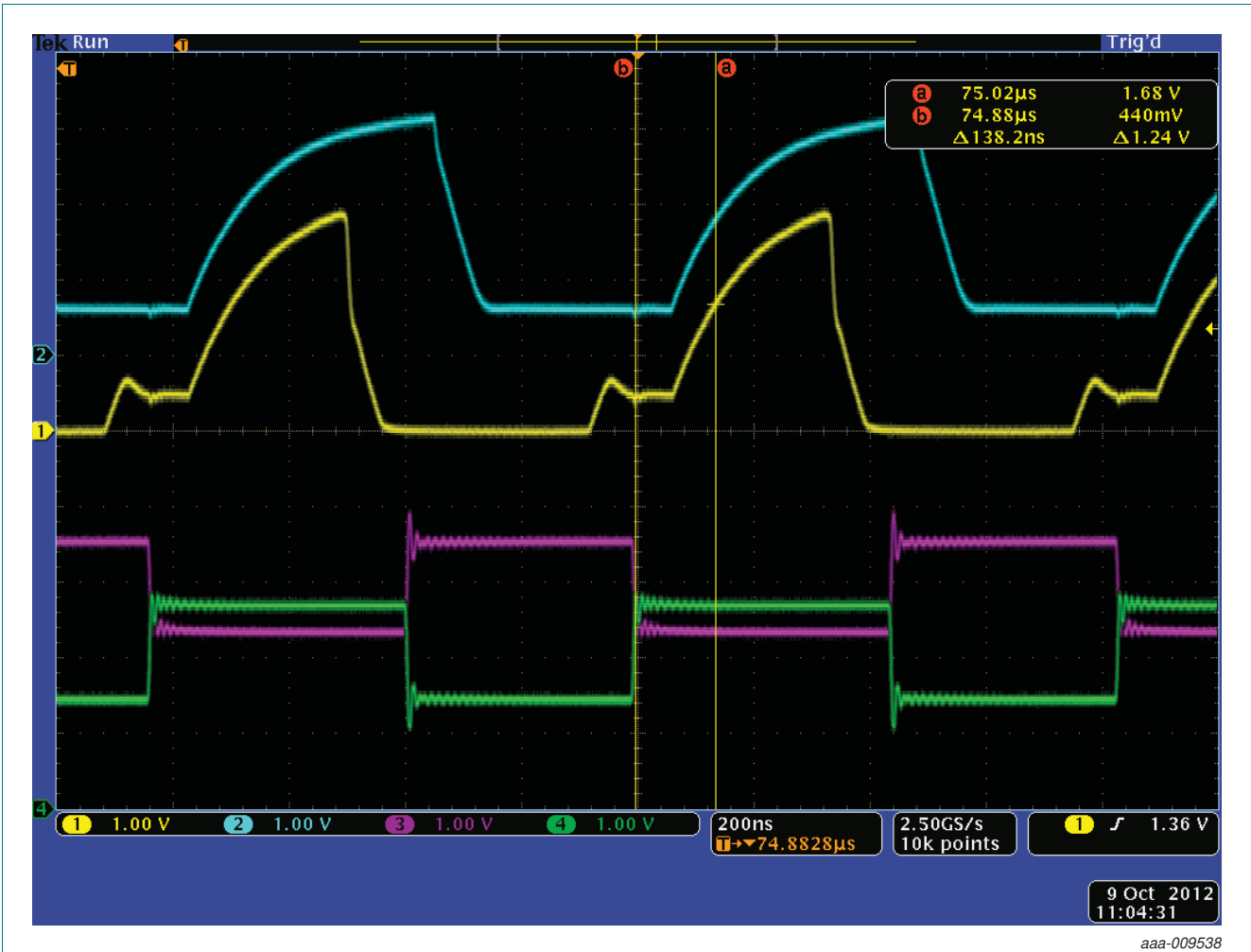

Fig 11. Differential bus waveform

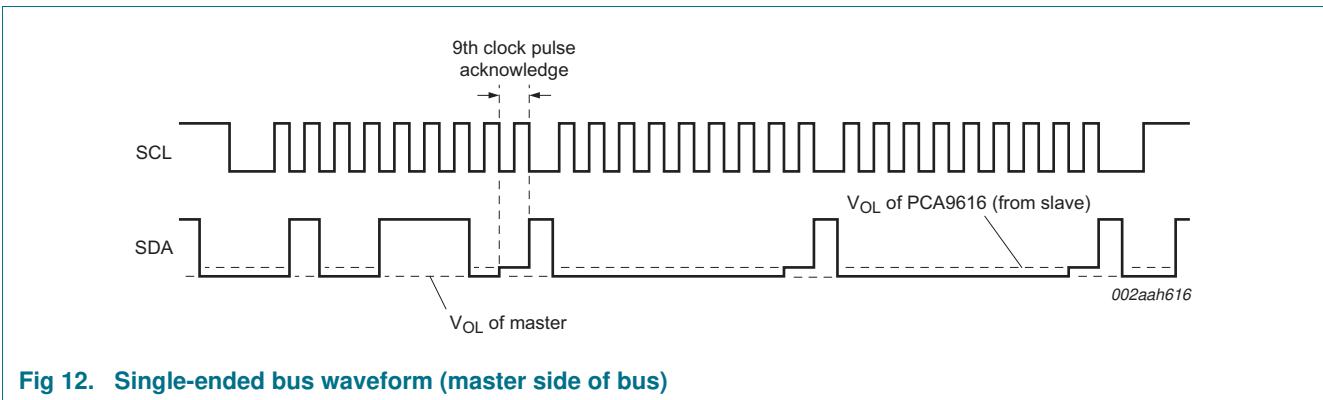

Fig 12. Single-ended bus waveform (master side of bus)

9. Limiting values

Table 4. Limiting values

In accordance with the Absolute Maximum Rating System (IEC 60134).

Symbol	Parameter	Conditions	Min	Max	Unit
V _{DD(B)}	supply voltage port B	differential bus; 3.0 V to 5.5 V	-0.5	+6	V
V _{DD(A)}	supply voltage port A	single-ended bus; 0.8 V to 5.5 V	-0.5	+6	V
V _{O(dif)}	differential output voltage		-0.5	+6	V
V _{bus}	bus voltage	voltage on I ² C-bus A side, or enable (EN)	-0.5	+6	V
I _{I/O}	input/output current	SDA, SCL, INT, Dxxxx pins	-	80	mA
		PIDET, READY pins	-	20	mA
I _{DD(B)}	supply current port B		-	160	mA
P _{tot}	total power dissipation		-	100	mW
T _{stg}	storage temperature		-55	+125	°C
T _{amb}	ambient temperature	operating in free air	-40	+85	°C
T _j	junction temperature		-	125	°C

10. Static characteristics

Table 5. Static characteristics

$V_{DD(B)} = 3.0\text{ V to }5.5\text{ V}$; $V_{SS} = 0\text{ V}$; $T_{amb} = -40\text{ °C to }+85\text{ °C}$; unless otherwise specified.

Symbol	Parameter	Conditions	Min	Typ	Max	Unit
Supplies						
$V_{DD(B)}$	supply voltage port B	differential bus	3.0	-	5.5	V
$V_{DD(A)}$	supply voltage port A	single-ended bus	1 0.8	-	5.5	V
$I_{DD(VDDA)}$	supply current on pin $V_{DD(A)}$		-	-	16	μA
$I_{DDH(B)}$	port B HIGH-level supply current	3-channel; both channels HIGH; $V_{DD(B)} = 5.5\text{ V}$; $\text{INT} = \text{SDAn} = \text{SCLn} = V_{DD(A)} = 5.5\text{ V}$	-	1.2	2.0	mA
$I_{DDL(B)}$	port B LOW-level supply current	3-channel; both channels LOW; $V_{DD(B)} = 5.5\text{ V}$; SDA and SCL = V_{SS} ; differential I/Os open	-	1.2	2.0	mA
		driving termination; 3 channels	-	95	136	mA
Input and output SDA and SCL and INT						
V_{IH}	HIGH-level input voltage		$0.7V_{DD(A)}$	-	5.5	V
V_{IL}	LOW-level input voltage	$VDDA_SEL = 1$ and $V_{DD(A)} > 2.2\text{ V}$	-0.5	-	+0.4	V
		$VDDA_SEL = 0$ and $V_{DD(A)} < 2.4\text{ V}$	-0.5	-	$+0.1V_{DD(A)}$	V
V_{IK}	input clamping voltage	$I_I = -18\text{ mA}$	-1.5	-	0	V
I_{LI}	input leakage current	$V_I = V_{DD(A)}$	-	-	± 2	μA
I_{IL}	LOW-level input current	$V_I = 0.2\text{ V}$ for $V_{DD(A)} > 1.8\text{ V}$; $V_I = 0.1\text{ V}$ for $V_{DD(A)} < 1.8\text{ V}$	-	-	12	μA
V_{OL}	LOW-level output voltage	$I_{OL} = 200\ \mu\text{A}$ or 30 mA ($V_{DD(A)} > 2.2\text{ V}$ and $VDDA_SEL = 1$)	0.47	0.52	0.6	V
		$I_{OL} = 200\ \mu\text{A}$ or 3 mA ($V_{DD(A)} < 2.4\text{ V}$ and $VDDA_SEL = 0$)	-	$0.2V_{DD(A)}$	$0.3V_{DD(A)}$	
$V_{OL} - V_{IL}$	difference between LOW-level output and LOW-level input voltage	guaranteed by design				
		$I_{OL} = 200\ \mu\text{A}$ or 30 mA ($V_{DD(A)} > 2.2\text{ V}$ and $VDDA_SEL = 1$)	-	-	90	mV
		$I_{OL} = 200\ \mu\text{A}$ or 3 mA ($V_{DD(A)} < 2.4\text{ V}$ and $VDDA_SEL = 0$)	-	$0.05V_{DD(A)}$	$0.1V_{DD(A)}$	
I_{LOH}	HIGH-level output leakage current	$V_O = V_{DD(A)}$	-	-	± 2	μA
C_{io}	input/output capacitance	$V_I = V_{DD(A)}$ or 0 V ; disabled or $V_{DD(A)} = 0\text{ V}$	-	7	10	pF

Table 5. Static characteristics ...continued

$V_{DD(B)} = 3.0\text{ V to }5.5\text{ V}$; $V_{SS} = 0\text{ V}$; $T_{amb} = -40\text{ }^{\circ}\text{C to }+85\text{ }^{\circ}\text{C}$; unless otherwise specified.

Symbol	Parameter	Conditions	Min	Typ	Max	Unit
Input and output DSDAP/DSDAM and DSCLP/DSCLM and DINTP/DINTM						
V_{cm}	common-mode voltage		0	-	$V_{DD(B)}$	V
I_{LI}	input leakage current	$V_I = V_{DD(B)}$				
		DSCLP, DSCLM, DSDAP, DSDAM pins	-	-	± 40	μA
		DINTP, DINTM pins	-	-	± 1	μA
I_{IL}	LOW-level input current	$V_I = 0.2\text{ V}$				
		DSCLP, DSCLM, DSDAP, DSDAM pins	-	-	± 40	μA
		DINTP, DINTM pins	-	-	± 1	μA
R_{PU}	pull-up resistance	internal pull-up resistor on DSCLM and DSDAM connected to $V_{DD(B)}$ rail	-	200	-	$\text{k}\Omega$
R_{pd}	pull-down resistance	internal pull-down resistor on DSCLP and DSDAP connected to V_{SS} rail	-	200	-	$\text{k}\Omega$
$V_{th(dif)}$	differential receiver threshold voltage	$0\text{ V} \leq V_{cm} \leq V_{DD(B)}$	-200	-	+200	mV
$V_{I(hys)}$	hysteresis of input voltage	receiver; $0\text{ V} \leq V_{cm} \leq V_{DD(B)}$	-	30	-	mV
$V_{o(dif)(p-p)}$	peak-to-peak differential output voltage	single-ended input LOW				
		no load	$-V_{DD(B)}$	-	-	V
		$R_L = 54\ \Omega$ at $V_{DD(B)} = 5\text{ V}$	-5.0	-1.5	-1.0	V
C_{io}	input/output capacitance	$V_I = V_{DD(B)}$ or 0 V ; disabled or $V_{DD(B)} = 0\text{ V}$	-	7	10	pF
Input EN						
V_{IH}	HIGH-level input voltage		$0.7V_{DD(A)}$	-	5.5	V
V_{IL}	LOW-level input voltage		-0.5	-	$+0.3V_{DD(A)}$	V
I_{LI}	input leakage current	$V_I = V_{DD(B)}$	-1	-	+1	μA
$I_{IL(EN)}$	LOW-level input current on pin EN	$V_I = 0.2\text{ V}$, EN; $V_{DD(A)} = 5.5\text{ V}$	-	-20	-54	μA
C_i	input capacitance	$V_I = V_{DD(A)}$	-	6	10	pF
R_{PU}	pull-up resistance	internal pull-up resistor connected to $V_{DD(A)}$ rail	-	300	-	$\text{k}\Omega$
Output PIDE\overline{T} and READ\overline{Y}						
V_{OL}	LOW-level output voltage	$I_{OL} = 3\text{ mA}$; $V_{DD(B)} = 3.0\text{ V}$	-0.5	-	+0.4	V
I_L	leakage current	$\overline{\text{READY}}$ and $\overline{\text{PIDE\overline{T}}}$ OFF; $V_{DD(A)} = V_{\text{PIDE\overline{T}}}/V_{\text{READY}} = 5.5\text{ V}$	-	-	± 2	μA
Input VDDA_SEL						
V_{IH}	HIGH-level input voltage		$0.7V_{DD(B)}$	-	5.5	V
V_{IL}	LOW-level input voltage		-0.5	-	$+0.3V_{DD(B)}$	V
I_{LI}	input leakage current	$V_{DD(B)} = 5.5\text{ V}$; $V_I = 0\text{ V}$ for $V_{DD(A)} = 1.8\text{ V}$, or $V_I = V_{DD(B)}$ for $V_{DD(A)} = 5.5\text{ V}$	-	-	± 1	μA

[1] Single-ended bus supply voltage. Recommend $VDDA_SEL = 0$ for $V_{DD(A)} = 0.8\text{ V to }2.4\text{ V}$, and $VDDA_SEL = 1$ for $V_{DD(A)} = 2.2\text{ V to }5.5\text{ V}$. If left floating, the best selection is automatically picked based on magnitude of $V_{DD(A)}$.

11. Dynamic characteristics

Table 6. Dynamic characteristics

$V_{DD} = 2.7\text{ V to }5.5\text{ V}$; $V_{SS} = 0\text{ V}$; $T_{amb} = -40\text{ }^{\circ}\text{C to }+85\text{ }^{\circ}\text{C}$; unless otherwise specified.^{[1][2]}

Symbol	Parameter	Conditions	Min	Typ ^[3]	Max	Unit
t _{PLH}	LOW to HIGH propagation delay	single-ended side to differential side; ^[4] Figure 15	-140	-120	-	ns
t _{PLH2}	LOW to HIGH propagation delay 2	single-ended side to differential side; Figure 15	-	-	100	ns
t _{PHL}	HIGH to LOW propagation delay	single-ended side to differential side; ^[5] Figure 13	-	-	120	ns
SR _r	rising slew rate	differential side; Figure 13	-	-	1	V/ns
SR _f	falling slew rate	differential side; Figure 13 ^[5]	-	-	1	V/ns
t _{PLH}	LOW to HIGH propagation delay	differential side to single-ended side; ^[6] Figure 14	-	-	150	ns
t _{PHL}	HIGH to LOW propagation delay	differential side to single-ended side; ^[6] Figure 14	-	-	150	ns
SR _f	falling slew rate	single-ended side; Figure 14	-	-	0.1	V/ns
t _{dis}	disable time	EN LOW to disable ^[7]	-	-	200	ns
t _{idle}	idle time	$\overline{\text{READY}}$ active after bus idle	-	100	-	μs
t _{stop}	stop time	$\overline{\text{READY}}$ active after bus stop	-	-	1	μs
t _{deb(bus)}	bus debounce time		5	-	15	ms

- [1] Times are specified with loads of 1.35 kΩ pull-up resistance and 50 pF load capacitance on the A side, and 50 Ω termination network resistance and 50 pF load capacitance on the B side. Different load resistance and capacitance will alter the RC time constant, thereby changing the propagation delay and transition times.
- [2] Pull-up voltages are V_{DD(A)} on the A side and termination network on the B side.
- [3] Typical values were measured with V_{DD(A)} = 3.3 V at T_{amb} = 25 °C, unless otherwise noted.
- [4] The t_{PLH} delay data from B side to A side is measured at 0 V differential on the B side to 0.5V_{DD(A)} on the A side.
- [5] Typical value measured with V_{DD(A)} = 3.3 V at T_{amb} = 25 °C.
- [6] The proportional delay data from A side to B side is measured at 0.5V_{DD(A)} on the A side to 0 V on the B side.
- [7] The enable pin (EN) should only change state when the global bus and the repeater port are in an idle state.

11.1 AC waveforms

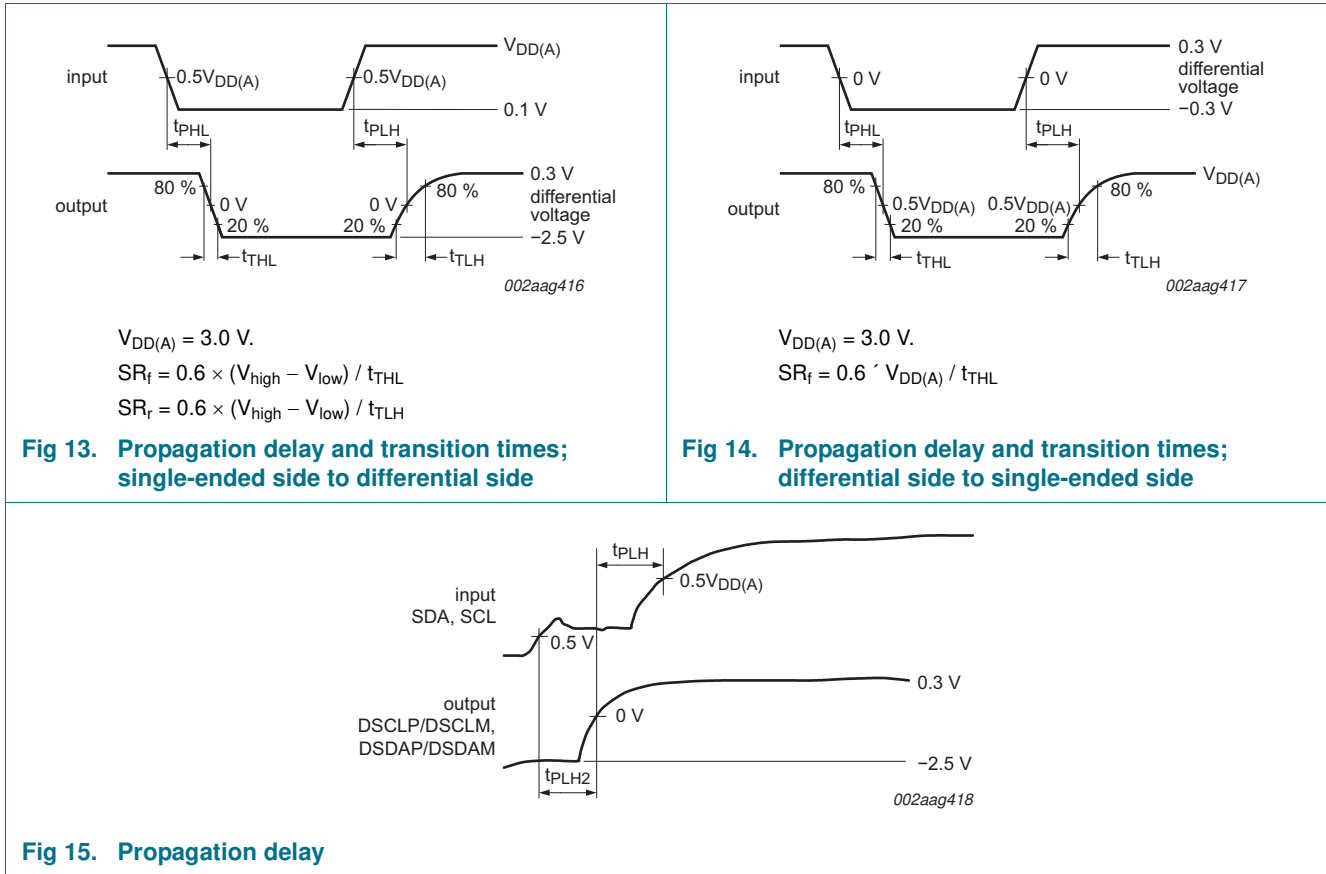

12. Test information

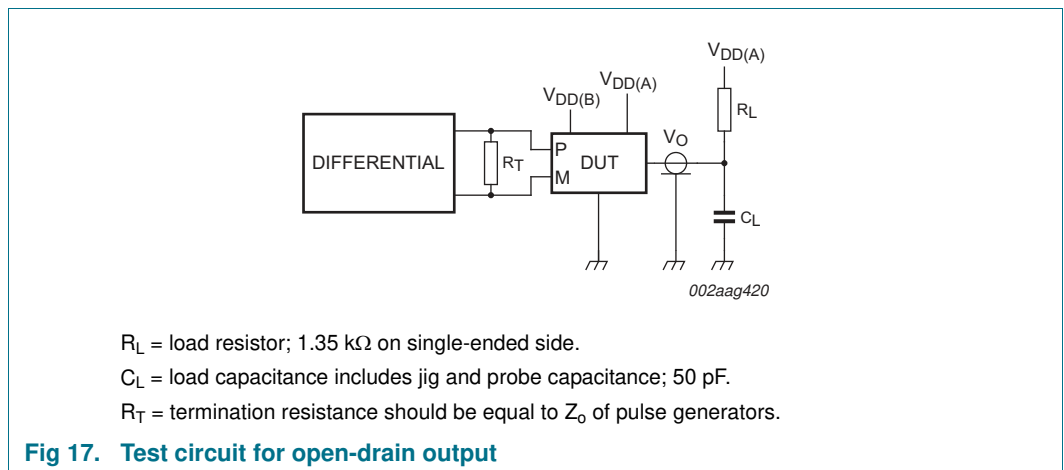
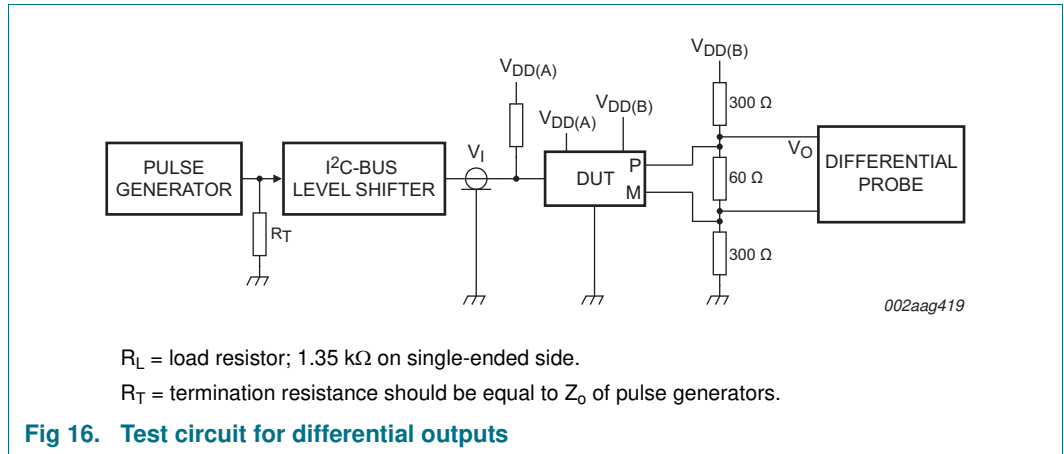

13. Package outline

TSSOP16: plastic thin shrink small outline package; 16 leads; body width 4.4 mm

SOT403-1

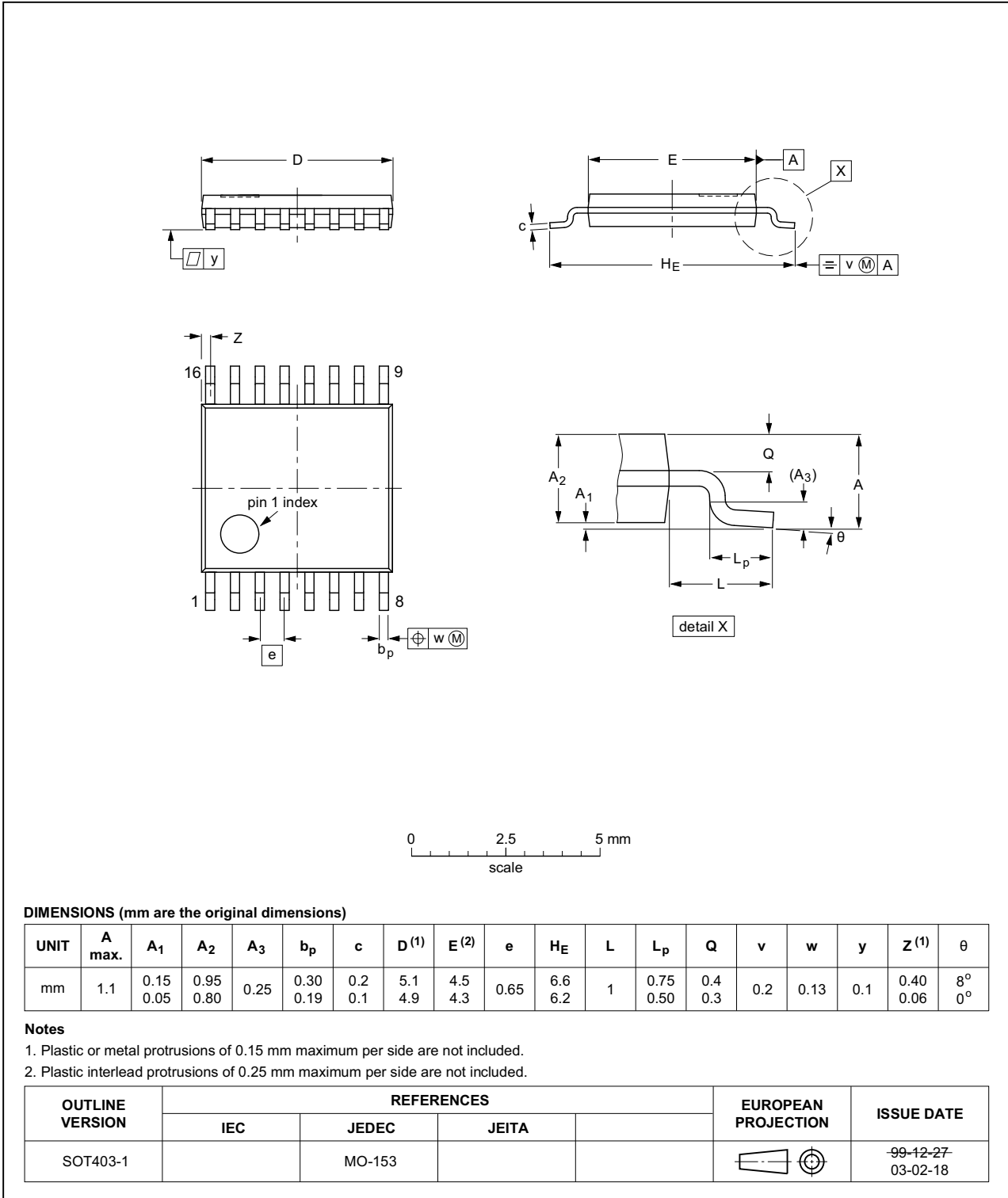

Fig 18. Package outline SOT403-1 (TSSOP16)

14. Soldering of SMD packages

This text provides a very brief insight into a complex technology. A more in-depth account of soldering ICs can be found in Application Note *AN10365 "Surface mount reflow soldering description"*.

14.1 Introduction to soldering

Soldering is one of the most common methods through which packages are attached to Printed Circuit Boards (PCBs), to form electrical circuits. The soldered joint provides both the mechanical and the electrical connection. There is no single soldering method that is ideal for all IC packages. Wave soldering is often preferred when through-hole and Surface Mount Devices (SMDs) are mixed on one printed wiring board; however, it is not suitable for fine pitch SMDs. Reflow soldering is ideal for the small pitches and high densities that come with increased miniaturization.

14.2 Wave and reflow soldering

Wave soldering is a joining technology in which the joints are made by solder coming from a standing wave of liquid solder. The wave soldering process is suitable for the following:

- Through-hole components
- Leaded or leadless SMDs, which are glued to the surface of the printed circuit board

Not all SMDs can be wave soldered. Packages with solder balls, and some leadless packages which have solder lands underneath the body, cannot be wave soldered. Also, leaded SMDs with leads having a pitch smaller than ~0.6 mm cannot be wave soldered, due to an increased probability of bridging.

The reflow soldering process involves applying solder paste to a board, followed by component placement and exposure to a temperature profile. Leaded packages, packages with solder balls, and leadless packages are all reflow solderable.

Key characteristics in both wave and reflow soldering are:

- Board specifications, including the board finish, solder masks and vias
- Package footprints, including solder thieves and orientation
- The moisture sensitivity level of the packages
- Package placement
- Inspection and repair
- Lead-free soldering versus SnPb soldering

14.3 Wave soldering

Key characteristics in wave soldering are:

- Process issues, such as application of adhesive and flux, clinching of leads, board transport, the solder wave parameters, and the time during which components are exposed to the wave
- Solder bath specifications, including temperature and impurities

14.4 Reflow soldering

Key characteristics in reflow soldering are:

- Lead-free versus SnPb soldering; note that a lead-free reflow process usually leads to higher minimum peak temperatures (see [Figure 19](#)) than a SnPb process, thus reducing the process window
- Solder paste printing issues including smearing, release, and adjusting the process window for a mix of large and small components on one board
- Reflow temperature profile; this profile includes preheat, reflow (in which the board is heated to the peak temperature) and cooling down. It is imperative that the peak temperature is high enough for the solder to make reliable solder joints (a solder paste characteristic). In addition, the peak temperature must be low enough that the packages and/or boards are not damaged. The peak temperature of the package depends on package thickness and volume and is classified in accordance with [Table 7](#) and [8](#)

Table 7. SnPb eutectic process (from J-STD-020D)

Package thickness (mm)	Package reflow temperature (°C)	
	Volume (mm ³)	
	< 350	≥ 350
< 2.5	235	220
≥ 2.5	220	220

Table 8. Lead-free process (from J-STD-020D)

Package thickness (mm)	Package reflow temperature (°C)		
	Volume (mm ³)		
	< 350	350 to 2000	> 2000
< 1.6	260	260	260
1.6 to 2.5	260	250	245
> 2.5	250	245	245

Moisture sensitivity precautions, as indicated on the packing, must be respected at all times.

Studies have shown that small packages reach higher temperatures during reflow soldering, see [Figure 19](#).

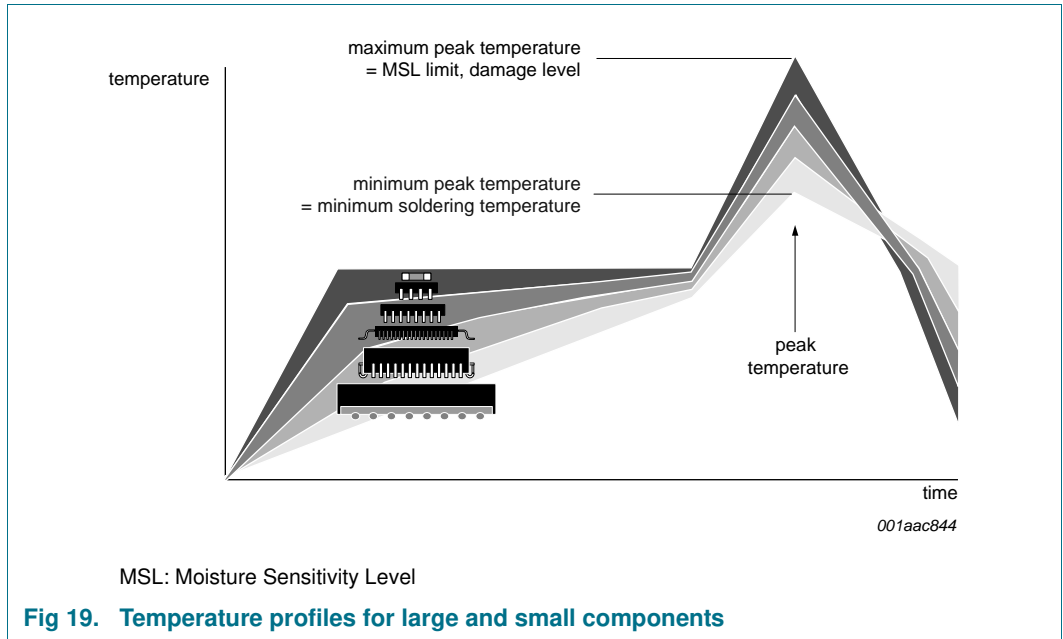

For further information on temperature profiles, refer to Application Note AN10365 “Surface mount reflow soldering description”.

15. Soldering: PCB footprints

Footprint information for reflow soldering of TSSOP16 package

SOT403-1

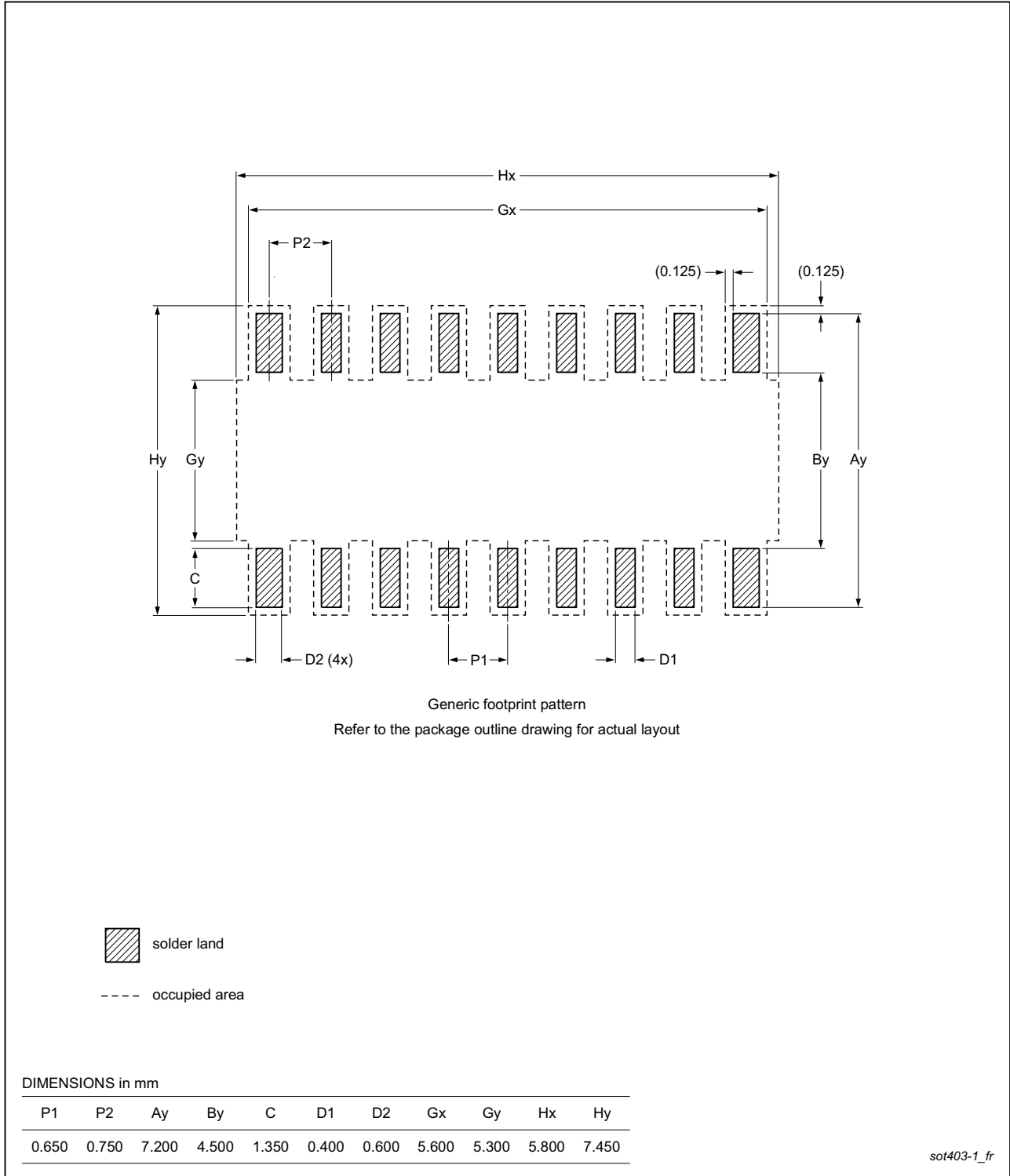

Fig 20. PCB footprint for SOT403-1 (TSSOP16); reflow soldering

16. Abbreviations

Table 9. Abbreviations

Acronym	Description
CDM	Charged-Device Model
dI ² C-bus	differential Inter-Integrated Circuit bus
ESD	ElectroStatic Discharge
HBM	Human Body Model
I ² C-bus	Inter-Integrated Circuit bus
I/O	Input/Output
LED	Light Emitting Diode
SMBus	System Management Bus

17. Revision history

Table 10. Revision history

Document ID	Release date	Data sheet status	Change notice	Supersedes
PCA9616 v.2	20140310	Product data sheet	-	PCA9616 v.1
Modifications:	<ul style="list-style-type: none"> Inserted the word “multipoint” in descriptive title of this data sheet Section 1 “General description”: <ul style="list-style-type: none"> added “Remark” paragraph eighth paragraph re-written Figure 1 “SMBus/I²C-bus translation to dI²C-bus and back to SMBus/I²C-bus” updated: added EN, $\overline{\text{PIDET}}$ and $\overline{\text{RESET}}$ pins Section 2 “Features and benefits”: <ul style="list-style-type: none"> added (new) first bullet item seventh bullet item changed from “and Fast-mode Plus at 1 MHz” to “and SMBus, Fast-mode Plus up to 1 MHz” Section 2 “Features and benefits”, tenth bullet item: <ul style="list-style-type: none"> second sub-bullet changed from “3 V differential output (unloaded: ~5 V, loaded: ~1.5 V)” to “1.5 V differential output with nominal terminals” sixth sub-bullet changed from “(1 MΩ typical)” to “(200 kΩ typical)” Figure 2 “Block diagram (level 0)” updated (added transistor on signal $\overline{\text{PIDET}}$) Figure 3 “Differential output driver simplified circuit” updated (corrected transistor types) Table 3 “Pin description”: <ul style="list-style-type: none"> updated description for V_{DD(A)} (pin 1) updated description for EN (pin 3) description for VDDA_SEL (pin 9) changed from “Floating is not information of V_{DD(A)} range. Recommend to be HIGH when V_{DD(A)} > 2.3 V and be LOW when V_{DD(A)} < 2.3 V through a resistor.” to “Floating automatically selects threshold based on V_{DD(A)} magnitude. Recommend to be HIGH when V_{DD(A)} > 2.2 V and be LOW when V_{DD(A)} < 2.4 V through a resistor.” Figure 5 “dI²C-bus terminations” corrected: from “DxxxN” to “DxxxM” (2 places) Added (new) Section 7.2.3 “Interrupt channel” Section 7.3 “EN pin”: first paragraph re-written 			

Table 10. Revision history ...continued

Document ID	Release date	Data sheet status	Change notice	Supersedes		
Modifications: (continued)	<ul style="list-style-type: none"> • Section 8.2 “Differential I²C-bus application”: <ul style="list-style-type: none"> – second paragraph, second sentence changed from “(R1, R2, R3)” to “(R1-R2-R1)” – third paragraph, second sentence changed from “R1 and R3 are 600 Ω” to “and R1 is 600 Ω” – 13th paragraph, first sentence changed from “R1, R2 and R3” to “R1-R2-R1” – Figure 7 “Typical application for PCA9616”: corrected pin names; added ‘Remark’; “R3” changed to “R1”; added dashed line to indicate optional connection • Figure 8 “PCA9616 application diagram; V_{DD} and V_{SS} are routed through the cable”: corrected pin names; corrected resistor label from “R3” to “R1”; added ‘Remark’ • Figure 9 “PCA9616 application diagram; V_{DD} and V_{SS} are not routed through the cable”: corrected pin names; added ‘Remark’ • Table 4 “Limiting values”: <ul style="list-style-type: none"> – V_{DD(A)}: combined voltage ranges to one Condition – deleted characteristic “I_{DD}, supply current” – added characteristic “I_{I/O}, input/output current” • Table 5 “Static characteristics”, sub-section “Supplies”: <ul style="list-style-type: none"> – I_{DDH(B)} Typ value changed from “0.9 mA” to “1.2 mA” – I_{DDL(B)} (condition ‘3-channel; both channels LOW; V_{DD(B)} = 5.5 V; SDA and SCL = V_{SS}; differential I/Os open’), Typ value changed from “1.5 mA” to “1.2 mA” – I_{DDL(B)} (condition ‘3-channel; both channels LOW; V_{DD(B)} = 5.5 V; SDA and SCL = V_{SS}; differential I/Os open’), Max value changed from “3.0 mA” to “2.0 mA” – I_{DDL(B)} (condition ‘driving termination; 3 channels’), Typ value changed from “105 mA” to “95 mA” • Table 5 “Static characteristics”, sub-section “Input and output SDA and SCL and INT”: <ul style="list-style-type: none"> – deleted characteristic “C_L, load capacitance” – I_{LI} Condition changed from “V_I = 5.5 V” to “V_I = V_{DD(A)}” – I_{LOH}: Condition changed from “V_O = 5.5 V” to “V_O = V_{DD(A)}”; Max value changed from “2 μA” to “±2 μA” – C_{io}: merged Conditions; Max value changed from “-” to “10 pF” • Table 5 “Static characteristics”, sub-section “Input and output DSDAP/DSDAM and DSCLP/DSCLM and DINTP/DINTM”: <ul style="list-style-type: none"> – V_{cm} Max value changed from “5.5 V” to “V_{DD(B)}” – I_{LI}: Condition changed from “V_I = 5.5 V” to “V_I = V_{DD(B)}” – I_{IL}: Condition changed from “SDA, SCL; V_I = 0.2 V” to “V_I = 0.2 V for V_{DD(A)} > 1.8 V; V_I = 0.1 V for V_{DD(A)} < 1.8 V” – V_{th(dif)}: Condition changed from “0 V ≤ V_{cm} ≤ 5.5 V” to “0 V ≤ V_{cm} ≤ V_{DD(B)}” – V_{I(hys)}: Condition changed from “receiver; 0 V ≤ V_{cm} ≤ 5.5 V” to “receiver; 0 V ≤ V_{cm} ≤ V_{DD(B)}”; Min value changed from “<td>” to “-”; Typ value changed from “<td>” to “30 mV”; Max value changed from “<td>” to “-” – C_{io}, merged Conditions; Max value changed from “-” to “10 pF” • Table 5 “Static characteristics”, sub-section “Input EN”: <ul style="list-style-type: none"> – I_{IL(EN)} Typ value changed from “-10 μA” to “-20 μA” – C_{io}: Max value changed from “-” to “10 pF” • Table 5 “Static characteristics”, sub-section “Input VDDA_SEL”: I_{LI} Conditions changed from “V_{DD(B)} = 5.5 V; V_I = 0 V for V_{DD(A)} < 1.8 V, or V_I = V_{DD(B)} for V_{DD(A)} > 2.5 V” to “V_{DD(B)} = 5.5 V; V_I = 0 V for V_{DD(A)} = 1.8 V, or V_I = V_{DD(B)} for V_{DD(A)} = 5.5 V” • Table 5 “Static characteristics”, Table note [1] re-written 					
PCA9616 v.1	20131002	Preliminary data sheet	-	-		

18. Legal information

18.1 Data sheet status

Document status ^{[1][2]}	Product status ^[3]	Definition
Objective [short] data sheet	Development	This document contains data from the objective specification for product development.
Preliminary [short] data sheet	Qualification	This document contains data from the preliminary specification.
Product [short] data sheet	Production	This document contains the product specification.

[1] Please consult the most recently issued document before initiating or completing a design.

[2] The term 'short data sheet' is explained in section "Definitions".

[3] The product status of device(s) described in this document may have changed since this document was published and may differ in case of multiple devices. The latest product status information is available on the Internet at URL <http://www.nxp.com>.

18.2 Definitions

Draft — The document is a draft version only. The content is still under internal review and subject to formal approval, which may result in modifications or additions. NXP Semiconductors does not give any representations or warranties as to the accuracy or completeness of information included herein and shall have no liability for the consequences of use of such information.

Short data sheet — A short data sheet is an extract from a full data sheet with the same product type number(s) and title. A short data sheet is intended for quick reference only and should not be relied upon to contain detailed and full information. For detailed and full information see the relevant full data sheet, which is available on request via the local NXP Semiconductors sales office. In case of any inconsistency or conflict with the short data sheet, the full data sheet shall prevail.

Product specification — The information and data provided in a Product data sheet shall define the specification of the product as agreed between NXP Semiconductors and its customer, unless NXP Semiconductors and customer have explicitly agreed otherwise in writing. In no event however, shall an agreement be valid in which the NXP Semiconductors product is deemed to offer functions and qualities beyond those described in the Product data sheet.

18.3 Disclaimers

Limited warranty and liability — Information in this document is believed to be accurate and reliable. However, NXP Semiconductors does not give any representations or warranties, expressed or implied, as to the accuracy or completeness of such information and shall have no liability for the consequences of use of such information. NXP Semiconductors takes no responsibility for the content in this document if provided by an information source outside of NXP Semiconductors.

In no event shall NXP Semiconductors be liable for any indirect, incidental, punitive, special or consequential damages (including - without limitation - lost profits, lost savings, business interruption, costs related to the removal or replacement of any products or rework charges) whether or not such damages are based on tort (including negligence), warranty, breach of contract or any other legal theory.

Notwithstanding any damages that customer might incur for any reason whatsoever, NXP Semiconductors' aggregate and cumulative liability towards customer for the products described herein shall be limited in accordance with the *Terms and conditions of commercial sale* of NXP Semiconductors.

Right to make changes — NXP Semiconductors reserves the right to make changes to information published in this document, including without limitation specifications and product descriptions, at any time and without notice. This document supersedes and replaces all information supplied prior to the publication hereof.

Suitability for use — NXP Semiconductors products are not designed, authorized or warranted to be suitable for use in life support, life-critical or safety-critical systems or equipment, nor in applications where failure or malfunction of an NXP Semiconductors product can reasonably be expected to result in personal injury, death or severe property or environmental damage. NXP Semiconductors and its suppliers accept no liability for inclusion and/or use of NXP Semiconductors products in such equipment or applications and therefore such inclusion and/or use is at the customer's own risk.

Applications — Applications that are described herein for any of these products are for illustrative purposes only. NXP Semiconductors makes no representation or warranty that such applications will be suitable for the specified use without further testing or modification.

Customers are responsible for the design and operation of their applications and products using NXP Semiconductors products, and NXP Semiconductors accepts no liability for any assistance with applications or customer product design. It is customer's sole responsibility to determine whether the NXP Semiconductors product is suitable and fit for the customer's applications and products planned, as well as for the planned application and use of customer's third party customer(s). Customers should provide appropriate design and operating safeguards to minimize the risks associated with their applications and products.

NXP Semiconductors does not accept any liability related to any default, damage, costs or problem which is based on any weakness or default in the customer's applications or products, or the application or use by customer's third party customer(s). Customer is responsible for doing all necessary testing for the customer's applications and products using NXP Semiconductors products in order to avoid a default of the applications and the products or of the application or use by customer's third party customer(s). NXP does not accept any liability in this respect.

Limiting values — Stress above one or more limiting values (as defined in the Absolute Maximum Ratings System of IEC 60134) will cause permanent damage to the device. Limiting values are stress ratings only and (proper) operation of the device at these or any other conditions above those given in the Recommended operating conditions section (if present) or the Characteristics sections of this document is not warranted. Constant or repeated exposure to limiting values will permanently and irreversibly affect the quality and reliability of the device.

Terms and conditions of commercial sale — NXP Semiconductors products are sold subject to the general terms and conditions of commercial sale, as published at <http://www.nxp.com/profile/terms>, unless otherwise agreed in a valid written individual agreement. In case an individual agreement is concluded only the terms and conditions of the respective agreement shall apply. NXP Semiconductors hereby expressly objects to applying the customer's general terms and conditions with regard to the purchase of NXP Semiconductors products by customer.

No offer to sell or license — Nothing in this document may be interpreted or construed as an offer to sell products that is open for acceptance or the grant, conveyance or implication of any license under any copyrights, patents or other industrial or intellectual property rights.

3-channel multipoint Fm+ dI²C-bus buffer with hot-swap logic

Export control — This document as well as the item(s) described herein may be subject to export control regulations. Export might require a prior authorization from competent authorities.

Non-automotive qualified products — Unless this data sheet expressly states that this specific NXP Semiconductors product is automotive qualified, the product is not suitable for automotive use. It is neither qualified nor tested in accordance with automotive testing or application requirements. NXP Semiconductors accepts no liability for inclusion and/or use of non-automotive qualified products in automotive equipment or applications.

In the event that customer uses the product for design-in and use in automotive applications to automotive specifications and standards, customer (a) shall use the product without NXP Semiconductors' warranty of the product for such automotive applications, use and specifications, and (b) whenever customer uses the product for automotive applications beyond NXP Semiconductors' specifications such use shall be solely at customer's

own risk, and (c) customer fully indemnifies NXP Semiconductors for any liability, damages or failed product claims resulting from customer design and use of the product for automotive applications beyond NXP Semiconductors' standard warranty and NXP Semiconductors' product specifications.

Translations — A non-English (translated) version of a document is for reference only. The English version shall prevail in case of any discrepancy between the translated and English versions.

18.4 Trademarks

Notice: All referenced brands, product names, service names and trademarks are the property of their respective owners.

I²C-bus — logo is a trademark of NXP Semiconductors N.V.

19. Contact information

For more information, please visit: <http://www.nxp.com>

For sales office addresses, please send an email to: salesaddresses@nxp.com

20. Contents

1	General description	1
2	Features and benefits	2
3	Applications	3
4	Ordering information	3
4.1	Ordering options	3
5	Block diagram	4
6	Pinning information	5
6.1	Pinning	5
6.2	Pin description	5
7	Functional description	6
7.1	I ² C-bus/SMBus side	6
7.2	dI ² C-bus side differential pair	6
7.2.1	Noise rejection	7
7.2.2	Rejection of ground offset voltage	7
7.2.3	Interrupt channel	7
7.3	EN pin	8
7.4	PIDET pin	8
7.5	READY pin	8
7.6	VDDA_SEL pin	8
7.7	Hot swap and power-on reset	8
8	Application design-in information	10
8.1	I ² C-bus	10
8.2	Differential I ² C-bus application	10
9	Limiting values	17
10	Static characteristics	18
11	Dynamic characteristics	20
11.1	AC waveforms	21
12	Test information	22
13	Package outline	23
14	Soldering of SMD packages	24
14.1	Introduction to soldering	24
14.2	Wave and reflow soldering	24
14.3	Wave soldering	24
14.4	Reflow soldering	25
15	Soldering: PCB footprints	27
16	Abbreviations	28
17	Revision history	28
18	Legal information	30
18.1	Data sheet status	30
18.2	Definitions	30
18.3	Disclaimers	30
18.4	Trademarks	31
19	Contact information	31
20	Contents	32

Please be aware that important notices concerning this document and the product(s) described herein, have been included in section 'Legal information'.

© NXP Semiconductors N.V. 2014.

All rights reserved.

For more information, please visit: <http://www.nxp.com>

For sales office addresses, please send an email to: salesaddresses@nxp.com

Date of release: 10 March 2014

Document identifier: PCA9616