



ON Semiconductor®

<http://onsemi.com>

# LV8800V

## Bi-CMOS IC For Notebook PC Fan Motor Driver

### Overview

The LV8800V is a motor driver for notebook PC fans.

### Feature

- Direct PWM sensorless motor driver

### Specifications

#### Absolute Maximum Ratings at Ta = 25°C

Parameter	Symbol	Conditions	Ratings	Unit
Power supply voltage	V <sub>CC</sub> max		6.5	V
Pre-drive voltage (gate voltage)	V <sub>G</sub> max		10	V
Output pin current	I <sub>OUT</sub> max		0.7	A
PWM input pin withstand voltage	V <sub>PWM</sub> max		V <sub>CC</sub>	V
FG output pin withstand voltage	V <sub>FG</sub> max		6.0	V
FG output current	I <sub>FG</sub> max		5.0	mA
Power dissipation 1	P <sub>d</sub> max1	Independent IC	0.3	W
Power dissipation 2	P <sub>d</sub> max2	Mounted on specified board *1	0.8	W
Operating temperature	T <sub>opr</sub>	*2	-30 to +95	°C
Storage temperature	T <sub>stg</sub>		-55 to +150	°C

\*1 : When mounted on 76.1mm×114.3mm×1.6mm glass epoxy board

\*2 : T<sub>j</sub> max = 150°C. Use the IC in the range where the temperature of the chip does not exceed T<sub>j</sub> = 150°C during operation.

Stresses exceeding Maximum Ratings may damage the device. Maximum Ratings are stress ratings only. Functional operation above the Recommended Operating Conditions is not implied. Extended exposure to stresses above the Recommended Operating Conditions may affect device reliability.

#### Recommended Operating Conditions at Ta = 25°C

Parameter	Symbol	Conditions	Ratings	Unit
Power supply voltage	V <sub>CC</sub>		2.2 to 6.0	V

# LV8800V

## Electrical Characteristics $T_a = 25^\circ\text{C}$ , $V_{CC} = 5\text{V}$ , unless specifically noted

Parameter	Symbol	Conditions	Ratings			Unit
			min	typ	max	
Power supply current 1	$I_{CC1}$	PWM pin = $V_{CC}$		1.8	2.5	mA
Power supply current 2	$I_{CC2}$	PWM pin = 0V		20	50	$\mu\text{A}$
<b>Charge pump output</b>						
Output voltage	VG			9.8		V
<b>Output block</b>						
Source	Ron (H)	$I_O = 0.5\text{A}$ , $V_G = 9.5\text{V}$		0.6	1.0	$\Omega$
Sink	Ron (L)	$I_O = 0.5\text{A}$ , $V_{CC} = 5.0\text{V}$		0.6	1.0	$\Omega$
Source + sink	Ron (H+L)	$I_O = 0.5\text{A}$ , $V_{CC} = 5\text{V}$ , $V_G = 9.5\text{V}$		1.2	2	$\Omega$
<b>Startup oscillation pin</b>						
OSC pin charge current	IOSC1			-2.5		$\mu\text{A}$
OSC pin discharge current	IOSC2			2.5		$\mu\text{A}$
<b>PWM input pin</b>						
PWM pin high-level input voltage	VPWMH		$V_{CC} \times 0.8$		$V_{CC}$	V
PWM pin low-level input voltage	VPWML		0		$V_{CC} \times 0.2$	V
PWM pin input current	IPWM	PWM pin = 0V			-50	$\mu\text{A}$
PWM input frequency	fPWM		20	25	50	kHz
<b>FG output pin</b>						
FG output pin low-level voltage	VFG	When $I_O = 0.5\text{mA}$		0.1	0.2	V
<b>Current limiter circuit</b>						
Limiter voltage	VRf	$R_F = 0.5\Omega$	0.225	0.25	0.275	V
<b>Constraint protection circuit</b>						
Constraint protection detection time	RDT1			0.5	1.0	s
Constraint protection release time	RDT2			5		s
<b>Thermal protection circuit</b>						
Thermal protection circuit operating temperature	TSD	Design target *	150	180		$^\circ\text{C}$
Temperature hysteresis width	$\Delta\text{TSD}$	Design target *		30		$^\circ\text{C}$

\* : Design target value and no measurement is made. The thermal protection circuit is incorporated to protect the IC from burnout or thermal destruction. Since it operates outside the IC's guaranteed operating range, the customer's thermal design should be performed so that the thermal protection circuit will not be activated when the fan is running under normal operating conditions.

## Package Dimensions

unit : mm (typ)

3178B

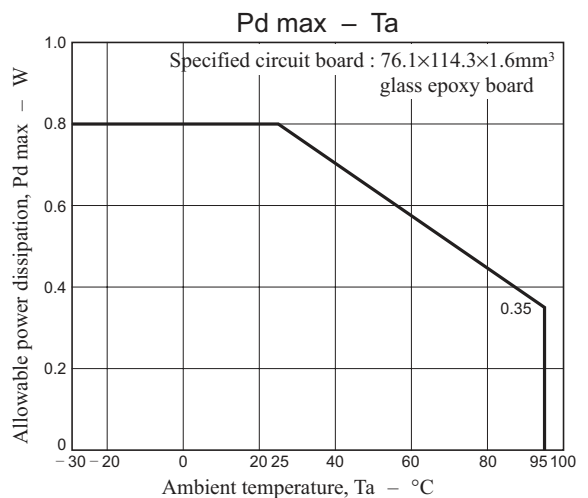
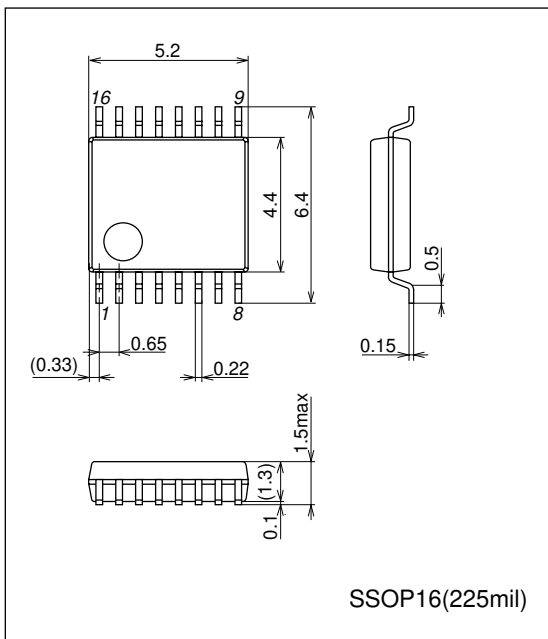

# LV8800V

## Pin Assignment

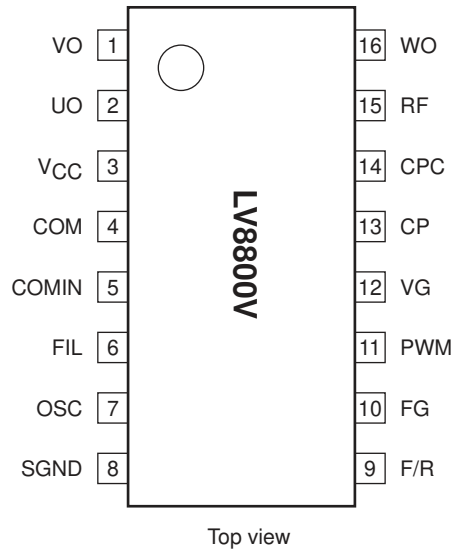

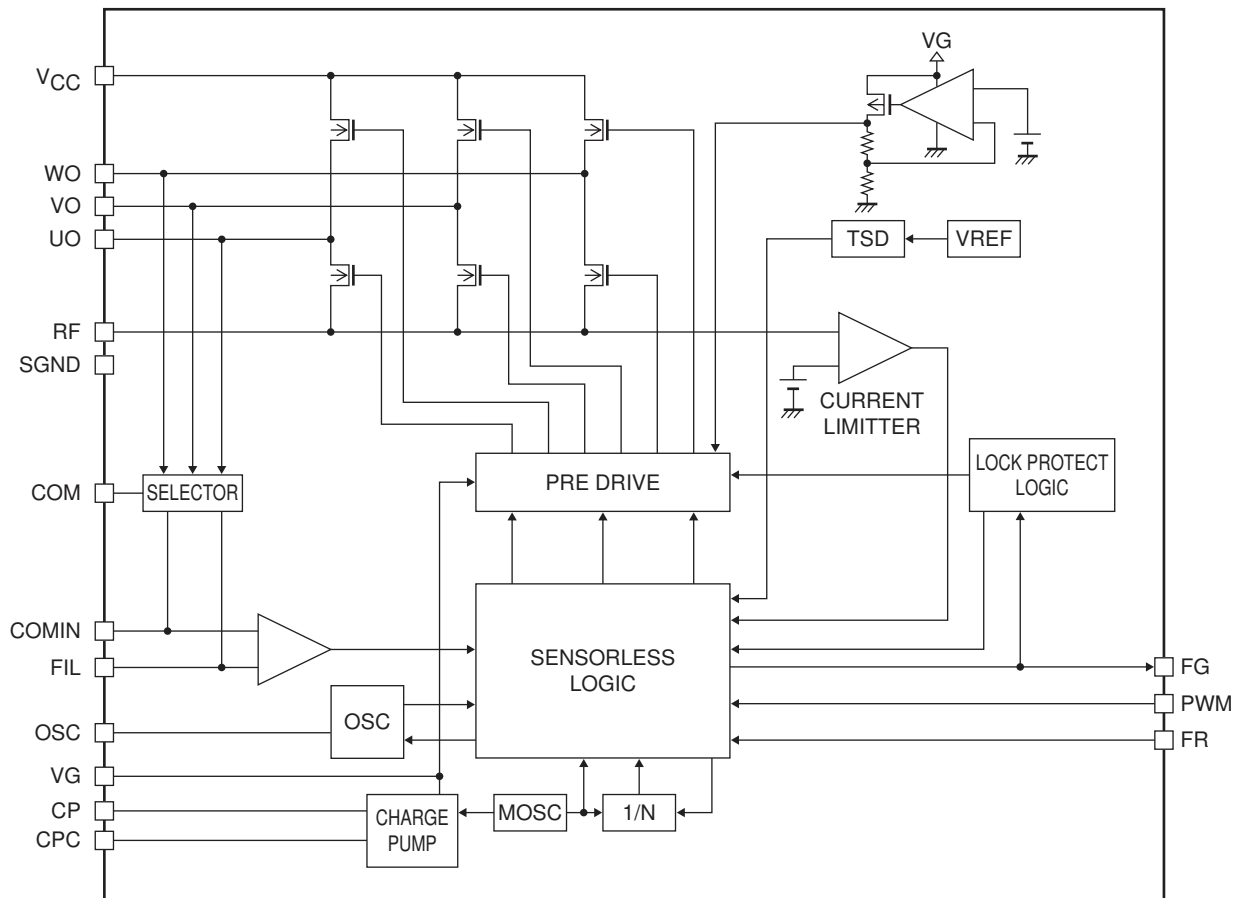

## Block Diagram

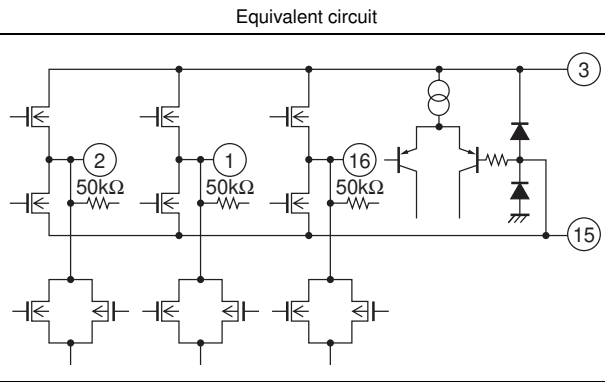
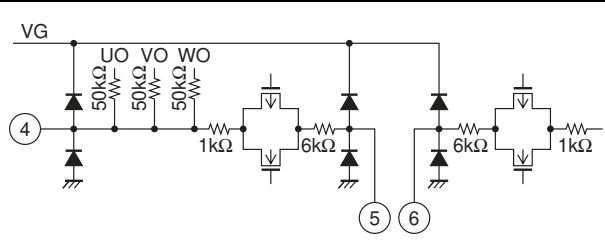
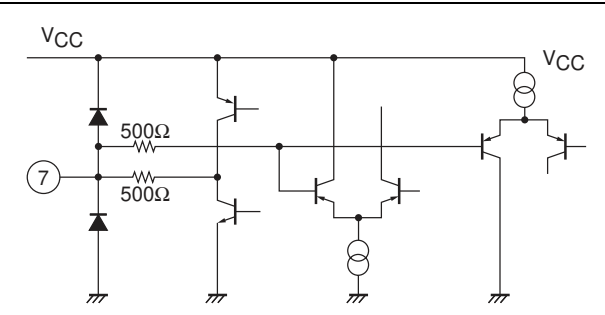
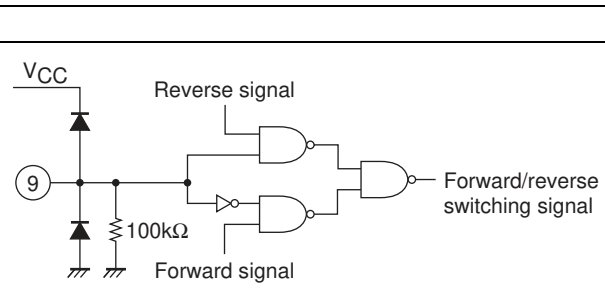
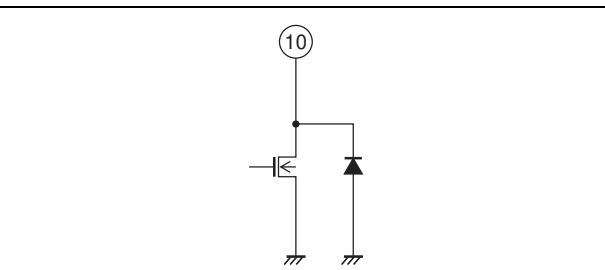
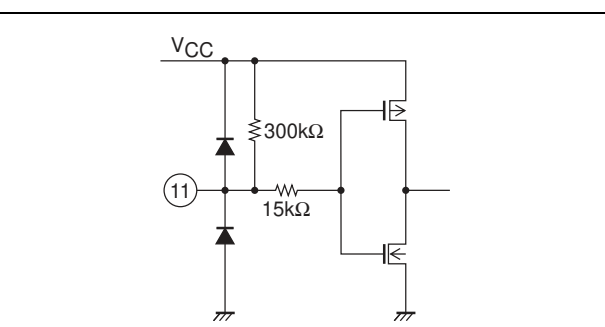

# LV8800V

## Pin Functions

Pin No.	Pin name	Function	Equivalent circuit
3	V <sub>CC</sub>	Power supply for the IC and motor. A capacitor must be connected between this pin and ground.	
2 1 16	UO VO WO	Output pins. Connect the motor coil.	
15	RF	Output current detection. The drive current is detected by connecting a resistor between this pin and ground.	
4	COM	Motor middle point connection.	
5	COMIN	Motor position detection comparator filter pin. A capacitor must be connected between this pin and the FIL pin (pin 6).	
6	FIL	Motor position detection comparator filter pin. A capacitor must be connected between this pin and the COMIN pin (pin 5).	
7	OSC	Motor startup frequency setting. A capacitor must be connected between this pin and ground. The startup frequency is adjusted by controlling the charge/discharge current ( $\pm 2.5\mu\text{A}$ ) and the capacitance of the capacitor.	
8	SGND	Ground for IC.	
9	F/R	Motor rotation direction switching. A high-level input causes current to flow into the motor in the order of U, V, and W and a low-level input in the order of U, W, and V. Changing the order of current application turns the motor in the opposite direction.	
10	FG	FG pulse output. This pin outputs a Hall sensor system equivalent pulse signal.	
11	PWM	PWM signal input. A high-level input turns on the output transistors. A low-level input turns off the output transistors and motor stops. The motor speed is set by controlling the duty cycle of the input PWM signal. The motor runs at full speed when this pin is held open.	

Continued on next page.

# LV8800V

Continued from preceding page.

Pin No.	Pin name	Function	Equivalent circuit
12	VG	Charge pump step-up output. A capacitor must be connected between this pin and ground.	
13	CP	Charge pump step-up pulse output pin. A capacitor must be connected between this pin and the CPC pin (pin 14).	
14	CPC	Charge pump step-up pin. A capacitor must be connected between this pin and the CP pin (pin 13).	

## LV8800V Functional Description and Notes on External Components

Read the following notes before designing driver circuits using the LV8800V to design a system with fully satisfactory characteristics.

### 1. Output drive circuit and speed control methods

The LV8800V adopts the synchronous commutation PWM drive method to minimize power loss in the output circuits. Low on-resistance DMOS devices (total high and low side on-resistance of output block : 1.2Ω, typical) are used as the output transistors.

The speed control of the driver is performed with an externally input PWM signal.

PWM controls the speed by performing switching in accordance with the duty cycle that is input to the PWM pin (11-pin). The output transistor is on when a high-level voltage is input to the PWM pin, and off when a low-level voltage is input. When the motor is used with the PWM pin open, the built-in resistor causes the PWM pin to change to high-level voltage and the motor speed rises to full speed. When the PWM pin is fixed at low-level voltage, the motor decelerates, and after the motor stops it enters "Power Saving Mode".

### 2. Soft Switching Circuit

This IC adopts variable duty soft switching to minimize the motor drive noise.

### 3. Current limiter circuit

The current limiter circuit limits the output current peak value to a level determined by the equation  $I = V_{RF}/R_F$  ( $V_{RF} = 0.25V$  typical). The current limiter circuit detects the peak current of the output transistors at the RF pin (pin 15) and turns off the transistor of the PWM phase.

### 4. OSC circuit

The OSC pin (pin 7) is an oscillation pin provided for sensorless motor startup commutation. When a capacitor is connected between the OSC pin and ground, the OSC pin starts self-oscillation, and this becomes the startup frequency. The oscillator frequency can be adjusted by changing the value of the external capacitor (i.e. reducing the value of the capacitor increases the startup frequency).

It is necessary to select a value of the capacitor that provides the optimal startup characteristics.

### 5. Position Detector Comparator Circuit for Rotor

The position detection comparator circuit for the rotor is a comparator for detecting rotor positional information with the back EMF signal generated when the motor rotates. The IC determines the timing at which the output block applies current to the motor based on the position information obtained here. Insert a capacitor (between 1,000 and 10,000pF) between the COMIN pin (pin 5) and FIL (pin 6) to prevent any motor startup missoperation that is caused by the comparator input noise.

### 6. FG Output Circuit

The FG pin (pin 10) is the FG output pin. It provides a pulse signal equivalent to that provided by systems that use a Hall-effect sensor.

## LV8800V

---

Since the FG pin has an open drain output structure, it must be used with a pull-up resistor. Connect a pull-up resistor on the side of the power supply where the FG signal is input. A pull-up resistor with a resistance of about 10k $\Omega$  is recommended.

## 7. Charge Pump Circuit

The LV8800V n-channel DMOS output structure allows it to provide a charge pump based voltage step-up circuit. A voltage 2 times the VCC voltage can be acquired by inserting capacitors (recommended value : 0.1 $\mu$ F or larger) between the CP pin (pin 13) and CPC pin (pin 14). Note that this circuit is designed so that the stepped-up voltage (VG) is clamped at about 9.5VDC. A larger capacitor must be used between the VG pin (pin 12) and ground if the ripple on the stepped-up voltage (VG) results in VG exceeding 10V(VG max).

Observe the following points if the VG voltage is supplied from external circuits.

- (1) The VG voltage supplied from the external circuits must not exceed the absolute maximum rating VG max.
- (2) The capacitors between the CP pin (pin 13) and CPC pin (pin 14) are not required.
- (3) Observe the correct sequence when turning the power supply on. Apply the VG voltage after first turning the VCC voltage on, and cancel the VG voltage application before turning the VCC off.
- (4) There is an IC-internal diode between the VCC and VG pins. Therefore, supply voltages such that VCC > VG must never be applied to this IC.

## 8. Notes on PCB Pattern Design

The LV8800V is a system driver IC implemented using the Bi-CMOS process; the IC chip includes bipolar circuits, MOS logic circuits, and MOS drive circuits. As a result, extreme care is required with respect to the pattern layout when designing application circuits.

### (1) Ground and VCC wiring layout

Insert a capacitor (recommended value : 1 $\mu$ F or larger) as near as possible to the pin between the power pin (pin 3) and ground pin (pin 8).

### (2) Positioning the external components

The external components that are connected to ground must be connected with lines that are as short as possible. External components connected between IC pins must be placed as near to the pins as possible.

## Application Circuit Example

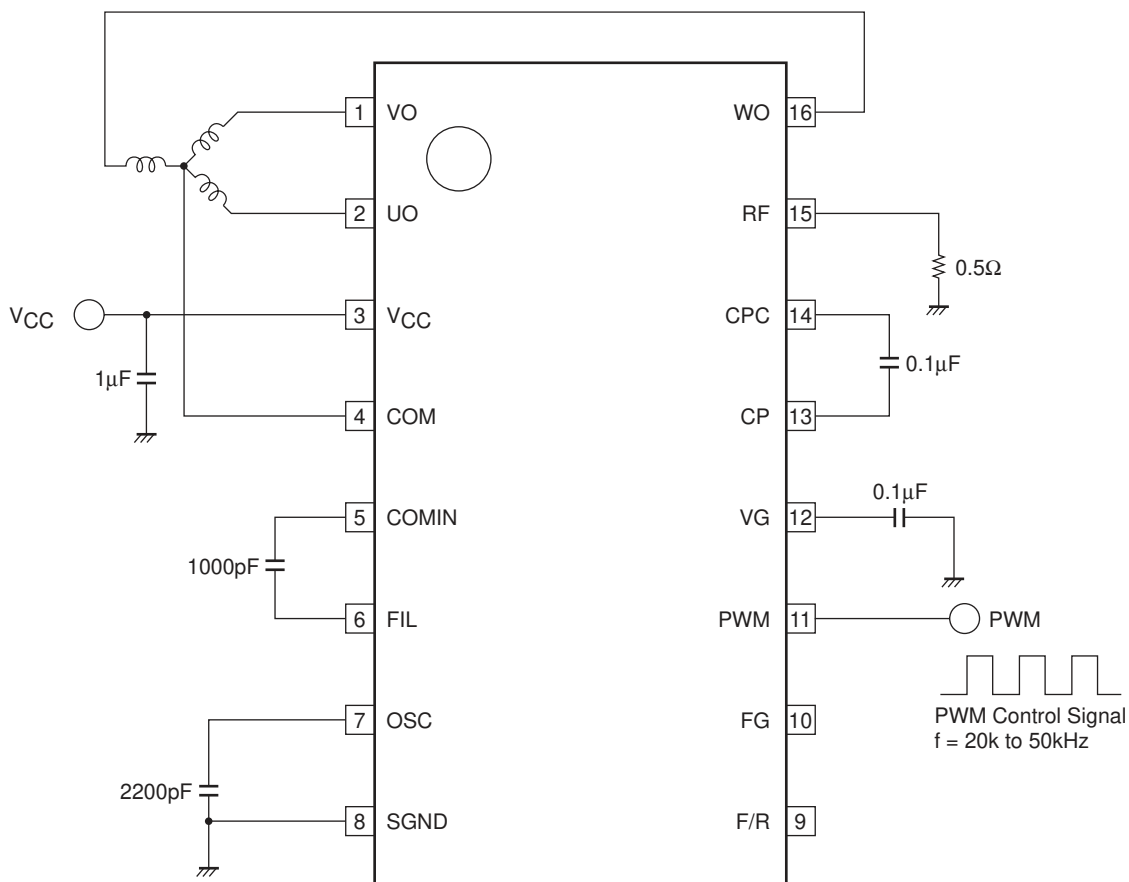

ON Semiconductor and the ON logo are registered trademarks of Semiconductor Components Industries, LLC (SCILLC). SCILLC owns the rights to a number of patents, trademarks, copyrights, trade secrets, and other intellectual property. A listing of SCILLC's product/patent coverage may be accessed at [www.onsemi.com/site/pdf/Patent-Marking.pdf](http://www.onsemi.com/site/pdf/Patent-Marking.pdf). SCILLC reserves the right to make changes without further notice to any products herein. SCILLC makes no warranty, representation or guarantee regarding the suitability of its products for any particular purpose, nor does SCILLC assume any liability arising out of the application or use of any product or circuit, and specifically disclaims any and all liability, including without limitation special, consequential or incidental damages. "Typical" parameters which may be provided in SCILLC data sheets and/or specifications can and do vary in different applications and actual performance may vary over time. All operating parameters, including "Typicals" must be validated for each customer application by customer's technical experts. SCILLC does not convey any license under its patent rights nor the rights of others. SCILLC products are not designed, intended, or authorized for use as components in systems intended for surgical implant into the body, or other applications intended to support or sustain life, or for any other application in which the failure of the SCILLC product could create a situation where personal injury or death may occur. Should Buyer purchase or use SCILLC products for any such unintended or unauthorized application, Buyer shall indemnify and hold SCILLC and its officers, employees, subsidiaries, affiliates, and distributors harmless against all claims, costs, damages, and expenses, and reasonable attorney fees arising out of, directly or indirectly, any claim of personal injury or death associated with such unintended or unauthorized use, even if such claim alleges that SCILLC was negligent regarding the design or manufacture of the part. SCILLC is an Equal Opportunity/Affirmative Action Employer. This literature is subject to all applicable copyright laws and is not for resale in any manner.