

## Features

- Low current consumption: 0.3µA typ. ( $V_{DD}=3.0V$ ,  $T_A = 25^{\circ}C$ )
- Wide operating voltage range: 1.35 to 5.5 V
- Minimum time keeping operation voltage: 1.25 V
- Built-in clock adjustment function
- Built-in free user register
- 3-wire (micro wire) CPU interface
- Built-in alarm interrupter
- Built-in flag generator at power down or power on
- Auto calendar up to the year 2099, automatic leap year calculation function
- Built-in constant voltage circuit
- Built-in 32 kHz crystal oscillator circuit
- Totally Lead-Free & Fully RoHS Compliant (Notes 1 & 2)
- Halogen and Antimony Free. "Green" Device (Note 3)
- For automotive applications requiring specific change control (i.e. parts qualified to AEC-Q100/101/200, PPAP capable, and manufactured in IATF 16949 certified facilities), please [contact us](#) or your local Diodes representative.
- <https://www.diodes.com/quality/product-definitions/>
- Packaging (Pb-free & Green):
  - 8-Pin, WDFN (ZE)

## Function Table

Item	Function		PT7C43190
1	Oscillator	Source	Crystal*
2	Time	Time display	12-hour
			24-hour
3	Interrupt	Alarm interrupt pin output	√2
		Timer interrupt output	√
4	Programmable square wave output (Hz)		1Hz,2Hz,4Hz 8Hz,16Hz 32kHz
5	Communication	3-wire bus	√
		Burst mode	√
6	Control	IC test mode	√
		Power-on detector	√
		Power supply voltage detector	√
7	Clock calibration		√
80	Free register access		√

Notes:  
 1. No purposely added lead. Fully EU Directive 2002/95/EC (RoHS), 2011/65/EU (RoHS 2) & 2015/863/EU (RoHS 3) compliant.  
 2. See <https://www.diodes.com/quality/lead-free/> for more information about Diodes Incorporated's definitions of Halogen- and Antimony-free, "Green" and Lead-free.  
 3. Halogen- and Antimony-free "Green" products are defined as those which contain <900ppm bromine, <900ppm chlorine (<1500ppm total Br + Cl) and <1000ppm antimony compounds.

## Description

The PT7C43190 is a CMOS 3-wire real-time clock IC, which operates with the very low current consumption and in the wide range of operation voltage. The operation voltage is 1.35 V to 5.5 V so that the RTC can be used for various power supplies from main supply to backup battery. In the system which operates with a backup battery, the included free registers can be used as the function for user's backup memory. Users always can take back the information in the registers which is stored before power-off the main power supply, after the voltage is restored.

The IC has the function to correct advance / delay of the clock data speed, in the wide range, which is caused by the oscillation circuit's frequency deviation. Correcting according to the temperature change by combining this function and a temperature sensor, it is possible to make a high precise clock function which is not affected by the ambient temperature.

## Applications

- Mobile Game Device
- Digital Still Camera
- Digital Video Camera
- Electronic Power Meter
- DVD Recorder
- TV, VCR
- Mobile Phone, PHS

**Block Diagram**

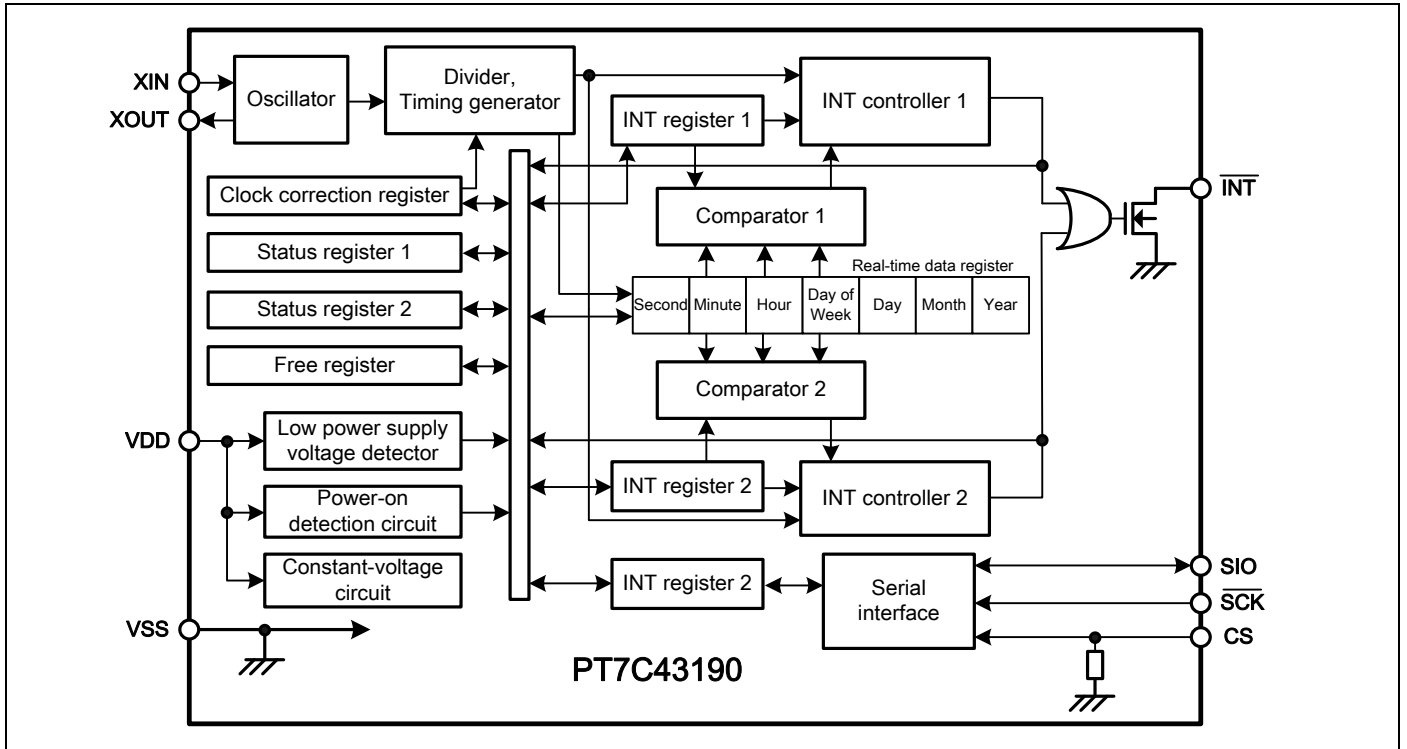

## Pin Configuration

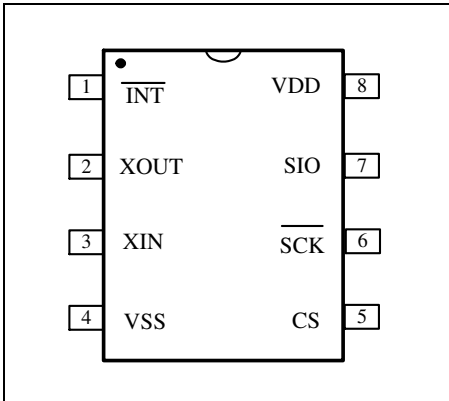

## Pin Description

Pin#	Pin Name	Type	Description
1	$\overline{\text{INT}}$	O	<b>Output for Interrupt Signal.</b> This pin outputs a signal of interrupt, or a clock pulse. By using the status register 2, users can select either of: alarm 1 interrupt, alarm 2 interrupt, output of user-set frequency, per-minute edge interrupt, minute-periodical interrupt 1, minute-periodical interrupt 2, or 32.768 kHz output. This pin has NCH open drain output.
2	XOUT	O	<b>Oscillator Circuit Output.</b> Together with X1, 32.768kHz crystal is connected between them. When 32.768kHz external input, X2 must be float.
3	XIN	I	<b>Oscillator Circuit Input.</b> Together with X1, 32.768kHz crystal is connected between them. Or external clock input.
4	VSS	P	<b>Negative power supply pin.</b> Connects to GND.
5	CS	I	<b>Chip select input pin.</b> This pin is to input chip select, has a pull-down resistor. Communication is available when this pin is in "H". If not using communication, set this pin "L" or open.
6	$\overline{\text{SCK}}$	I	<b>Serial clock input pin.</b> This pin is to input a clock pulse for serial interface. When the CS pin is in "H", the SIO pin inputs / outputs data by synchronizing with the clock pulse. When the CS pin is in "L" or open, the SCK pin does not accept inputting a clock pulse.
7	SIO	I/O	<b>Serial Data I/O pin.</b> This pin is a data input / output pin of serial interface. When the CS pin is in "H", the SIO pin inputs / outputs data by synchronizing with a clock pulse from the SCK pin. The status is in "High-Z" when the CS pin is in "L" or open, so that the chip does not transmit data. Setting the CS pin to "H" from "L" or open, this SIO pin goes in the input status so that it receives the command data. This pin has CMOS input and NCH open drain output.
8	VDD	P	<b>Positive power supply pin.</b> Connect this VDD pin with a positive power supply.

## Maximum Ratings

Storage Temperature .....	-55°C to +125°C
Power Supply Voltage .....	V <sub>SS</sub> -0.3V to V <sub>SS</sub> +6.5V
DC Input Voltage (CS, SCK, SIO) .....	V <sub>SS</sub> -0.3V to V <sub>SS</sub> +6.5V
DC Output Voltage (SIO, 32KO, SDA, INT) .....	V <sub>SS</sub> -0.3V to V <sub>SS</sub> +6.5V
Control Input Voltage (EN).....	-0.5V to +6.0V
Power Dissipation .....	250mW
Junction Temperature.....	125°C max

### Note:

Stresses greater than those listed under MAXIMUM RATINGS may cause permanent damage to the device. This is a stress rating only and functional operation of the device at these or any other conditions above those indicated in the operational sections of this specification is not implied. Exposure to absolute maximum rating conditions for extended periods may affect reliability.

## Recommended Operating Conditions

Symbol	Parameter	Conditions	Min	Typ	Max	Unit
V <sub>DD</sub>	Power supply voltage	T <sub>A</sub> = -40 to +85°C	1.35	3.0	5.5	V
T <sub>OPR</sub>	Operating temperature	V <sub>DD</sub> = 1.35 to 5.5 V	-40	+25	+85	°C
V <sub>DDT</sub>	Time keeping voltage range	T <sub>A</sub> = -40 to +85°C	1.25	-	5.5	V
V <sub>DDR</sub>	Register data hold voltage	T <sub>A</sub> = -40 to +85°C	0.9	-	5.5	V
C <sub>L</sub>	Crystal oscillator C <sub>L</sub> value	-	-	6	12.5	pF

**Note\*:** Reference value

## Oscillation Characteristics

(T<sub>A</sub> = 25°C, V<sub>DD</sub> = 3.0 V, V<sub>SS</sub> = 0 V, crystal oscillator (C<sub>L</sub> = 6 pF, 32.768 kHz).)

Symbol	Parameter	Conditions	Min.	Typ.	Max.	Unit
V <sub>STA</sub>	Oscillation start voltage	Within 10 seconds	1.1	-	5.5	V
-	Oscillation start time	-	-	-	3	s
δIC	IC to IC frequency deviation	-	-10	-	+10	ppm
δV	Frequency voltage deviation	V <sub>DD</sub> = 1.3 to 5.5 V	-3	-	+3	ppm

**DC Electrical Characteristics**

 (T<sub>A</sub> = -40°C to +85°C; V<sub>SS</sub> = 0V, crystal oscillator C<sub>L</sub> = 6pF, 32.768 KHz, unless otherwise noted.)

Symbol	Parameter	Pin	Test Conditions	Min	Typ	Max	Unit
V <sub>DD</sub> = 3.0V							
I <sub>DD1</sub>	Current consumption 1	V <sub>DD</sub>	Out of communication	-	0.3	0.6	uA
I <sub>DD2</sub>	Current consumption 2	V <sub>DD</sub>	During communication (SCK=100kHz)	-	2.5	8	uA
I <sub>IZH</sub>	Input high leakage current	SCK,SIO	V <sub>IN</sub> = V <sub>DD</sub>	-0.5	-	+0.5	uA
I <sub>IZL</sub>	Input low leakage current	SCK,SIO	V <sub>IN</sub> = V <sub>SS</sub>	-0.5	-	+0.5	uA
I <sub>I1</sub>	Input current 1	CS	V <sub>IN</sub> = V <sub>DD</sub>	-	0	-	uA
I <sub>I2</sub>	Input current 2	CS	V <sub>IN</sub> = 0.4V	-	1.3	-	uA
I <sub>I3</sub>	Input current 3	CS	V <sub>IN</sub> = 1.0V	-	2.6	-	uA
I <sub>OZH</sub>	Output high leakage current	SIO,INT,32kO	V <sub>OUT</sub> = V <sub>DD</sub>	-0.5	-	+0.5	uA
I <sub>OZL</sub>	Output low leakage current	SIO,INT,32kO	V <sub>OUT</sub> = V <sub>SS</sub>	-0.5	-	+0.5	uA
V <sub>IH</sub>	Input high voltage	SCK,SIO,CS	-	0.8 V <sub>DD</sub>	-	-	
V <sub>IL</sub>	Input low voltage	SCK,SIO,CS	-	-	-	0.2 V <sub>DD</sub>	
I <sub>OL1</sub>	Output low current 1	INT, 32kO	V <sub>OUT</sub> = 0.4V	1.0	1.4	-	mA
I <sub>OL3</sub>	Output low current 2	SIO	V <sub>OUT</sub> = 0.4V	5	10	-	mA
V <sub>DET</sub>	Power supply voltage detection voltage *1	-	-	0.70	1.05	1.40	V
V <sub>DD</sub> = 5.0V							
I <sub>DD1</sub>	Current consumption 1	V <sub>DD</sub>	Out of communication	-	0.35	0.7	uA
I <sub>DD2</sub>	Current consumption 2	V <sub>DD</sub>	During communication (SCK=100kHz)	-	5.0	14	uA
I <sub>IZH</sub>	Input high leakage current	SCK,SIO	V <sub>IN</sub> = V <sub>DD</sub>	-0.5	-	+0.5	uA
I <sub>IZL</sub>	Input low leakage current	SCK,SIO	V <sub>IN</sub> = V <sub>SS</sub>	-0.5	-	+0.5	uA
I <sub>I1</sub>	Input current 1	CS	V <sub>IN</sub> = V <sub>DD</sub>	-	0	-	uA
I <sub>I2</sub>	Input current 2	CS	V <sub>IN</sub> = 0.4V	-	2.3	-	uA
I <sub>I3</sub>	Input current 3	CS	V <sub>IN</sub> = 1.0V	-	5.0	-	uA
I <sub>OZH</sub>	Output high leakage current	SIO,INT,32kO	V <sub>OUT</sub> = V <sub>DD</sub>	-0.5	-	+0.5	uA
I <sub>OZL</sub>	Output low leakage current	SIO,INT,32kO	V <sub>OUT</sub> = V <sub>SS</sub>	-0.5	-	+0.5	uA
V <sub>IH</sub>	Input high voltage	SCK,SIO,CS	-	0.8 V <sub>DD</sub>	-	-	
V <sub>IL</sub>	Input low voltage	SCK,SIO,CS	-	-	-	0.2 V <sub>DD</sub>	
I <sub>OL1</sub>	Output low current 1	INT, 32kO	V <sub>OUT</sub> = 0.4V	1.0	1.4	-	mA
I <sub>OL3</sub>	Output low current 2	SIO	V <sub>OUT</sub> = 0.4V	6	13	-	mA
V <sub>DET</sub>	Power supply voltage detection voltage *1	-	-	0.70	1.05	1.40	V

**Note:**

 \*1. Power supply voltage detection voltage: Constantly maintains the relation of V<sub>DET</sub> > V<sub>DDRM</sub> (minimum register data hold voltage).

## AC Electrical Characteristics

### Measure conditions

Input pulse voltage	$V_{IH} = 0.8 \times V_{DD}$ , $V_{IL} = 0.2 \times V_{DD}$
Input pulse rise/fall time	20ns
Output determination voltage	$V_{OH} = 0.8 \times V_{DD}$ , $V_{OL} = 0.2 \times V_{DD}$
Output load	80pF + pull-up resistance 10k $\Omega$

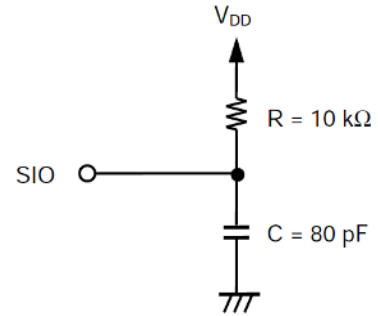

Output Load Circuit

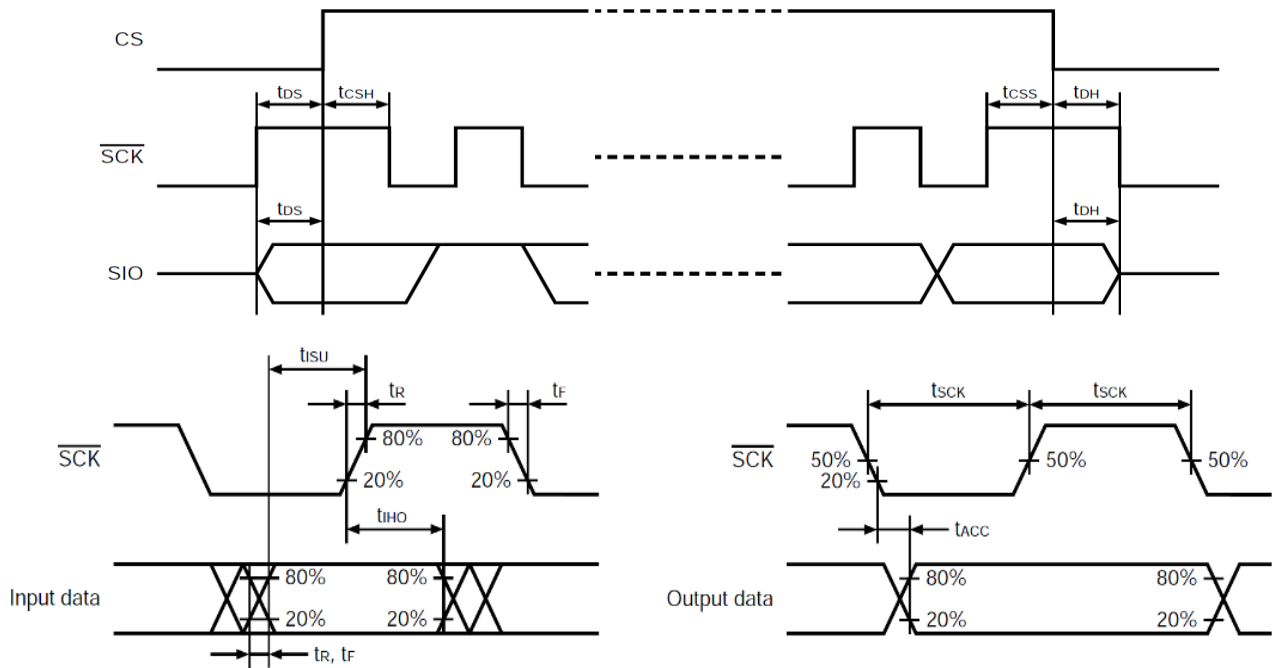

Symbol	Parameter	$V_{DD} = 1.35 \text{ to } 3.0 \text{ V (} V_{DD} = 3.0 \text{ V)}$			$V_{DD} = 1.35 \text{ to } 5.5 \text{ V (} V_{DD} = 5.5 \text{ V)}$			Unit
		Min.	Typ.	Max.	Min.	Typ.	Max.	
$t_{SCK}$	Clock pulse width	5	-	250000	1	-	250000	$\mu\text{s}$
$t_{DS}$	Setup before CS rise	1	-	-	0.2	-	-	$\mu\text{s}$
$t_{CSH}$	Hold time after CS rise	1	-	-	0.2	-	-	$\mu\text{s}$
$t_{ISU}$	Input setup time	1	-	-	0.2	-	-	$\mu\text{s}$
$t_{IHO}$	Input data hold time	1	-	-	0.2	-	-	$\mu\text{s}$
$t_{ACC}$	Output definition time <sup>*1</sup>	-	-	3.5	-	-	-	$\mu\text{s}$
$t_{CSS}$	Setup before CS fall	1	-	-	0.2	-	-	$\mu\text{s}$
$t_{DHF}$	Hold time after CS fall	1	-	-	0.2	-	-	$\mu\text{s}$
$t_R, t_F$	Input rise/fall time	-	-	0.1	-	-	0.05	$\mu\text{s}$

\*1. Since the output format of the SIO pin is Nch open-drain output, output data definition time is determined by the values of the load resistance ( $R_L$ ) and load capacity ( $C_L$ ) outside the IC. Therefore, use this value only as a reference value.

### Recommended Layout for Crystal

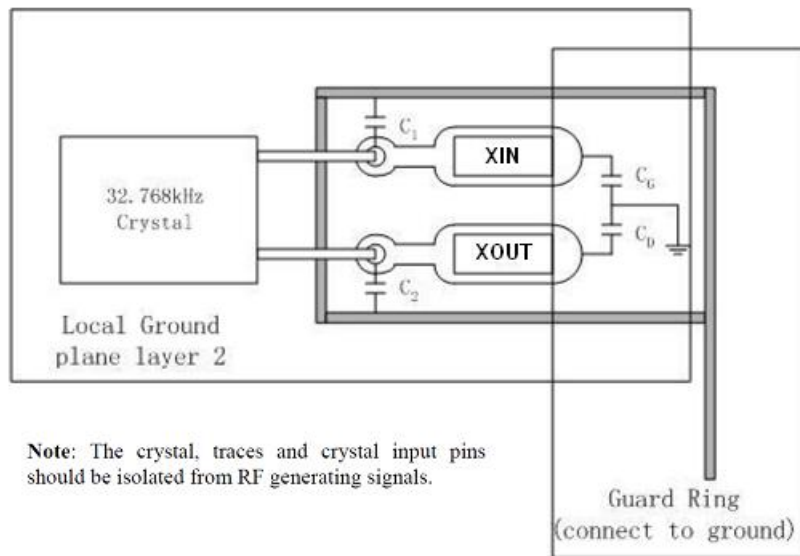

### Built-in Capacitors Specifications and Recommended External Capacitors

Parameter		Symbol	Typ.	Unit
Build in capacitors	XIN to GND	C <sub>G</sub>	5	pF
	XOUT to GND	C <sub>D</sub>	5	pF
Recommended External capacitors for crystal C <sub>L</sub> =12.5pF	XIN to GND	C1	18	pF
	XOUT to GND	C2	18	pF
Recommended External capacitors for crystal C <sub>L</sub> =6pF	XIN to GND	C1	7	pF
	XOUT to GND	C2	7	pF

**Note:** The frequency of crystal can be optimized by external capacitor C1 and C2, for frequency=32.768 kHz, C1 and C2 should meet the equation as below:  $C_{par} + \frac{[(C1+CG)*(C2+CD)]}{[(C1+CG) + (C2+CD)]} = CL$   
 C<sub>par</sub> is all parasitical capacitor between X1 and X2.  
 CL is crystal's load capacitance.

### Crystal Specifications

Parameter	Symbol	Min.	Typ.	Max.	Unit
Nominal frequency	f <sub>0</sub>	-	32.768	-	kHz
Serial resistance	ESR	-	-	70	kΩ
Load capacitance	C <sub>L</sub>	-	6/12.5	-	pF

## Functional Description

### 1. Overview of Functions

#### 1.1. Clock Function

CPU can read or write data including the year (last two digits), month, date, day, hour, minute, and second. Any (two-digit) year that is a multiple of 4 is treated as a leap year and calculated automatically as such until the year 2099.

#### 1.2. Alarm Function

This device has two alarm system (Alarm 1 and Alarm 2) that outputs interrupt signals from INT pin to CPU when the date, day of the week, hour, minute or second correspond to the setting. Each of them may output interrupt signal separately at a specified time. The alarm may be selectable between on and off for matching alarm or repeating alarm.

#### 1.3. Programmable Square Wave Output

For PT7C43190, square wave output at pin 1. Six frequencies are selectable: 1, 2, 4, 8, 16, 32768 Hz.

#### 1.4. Interface with CPU

PT7C43190: 3-wire interface.

#### 1.5. Calibration Function

With the calibration bits properly set, the accuracy can be improved to better than  $\pm 2$  ppm at 25°C.

## 2. Configuration of Data Communication

### 2.1. Data Communication

After setting the CS pin "H", transmit the 4-bit fixed code "0110", after that, transmit a 3-bit command and 1-bit read /write command. Next, data is output or input from B7. Regarding details refer to "3-wire Serial Interface".

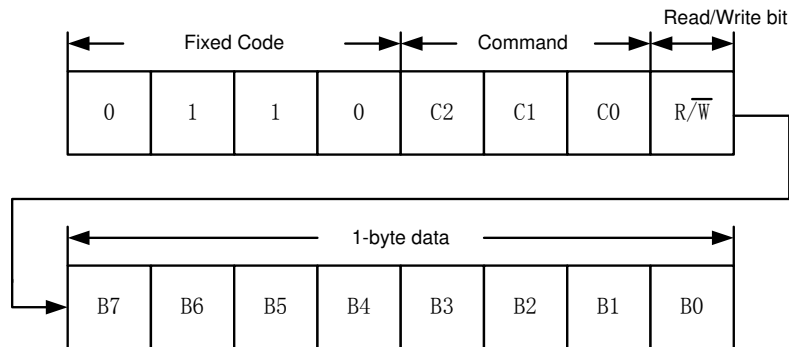



## 2.2. Configuration of Command

8 types of command are available for the RTC. The RTC reads / writes the various registers by inputting these fixed codes and commands. The RTC does not perform any operation with any codes and commands other than those below. However, in case that the fixed codes or the commands are failed to be recognized in the 1st byte but are successfully recognized in the 2nd and higher bytes, the commands are executed.

Fixed Code	Command			Data								
	C2	C1	C0	Description	B7	B6	B5	B4	B3	B2	B1	B0
0110	0	0	0	Status register 1 access	RESET <sup>*1</sup>	$\overline{12/24}$	SC0 <sup>*2</sup>	SC1 <sup>*2</sup>	INT1 <sup>*3</sup>	INT2 <sup>*3</sup>	BLD <sup>*4</sup>	POC <sup>*4</sup>
	0	0	1	Status register 2 access	INT1FE	INT1ME	INT1AE	32kE	SC2 <sup>*2</sup>	SC3 <sup>*2</sup>	INT2AE	TEST <sup>*5</sup>
	0	1	0	Real-time data 1 access (year data to)	Y1	Y2	Y4	Y8	Y10	Y20	Y40	Y80
					M1	M2	M4	M8	M10	$\overline{^6}$	$\overline{^6}$	$\overline{^6}$
					D1	D2	D4	D8	D10	D20	$\overline{^6}$	$\overline{^6}$
					W1	W2	W4	$\overline{^6}$	$\overline{^6}$	$\overline{^6}$	$\overline{^6}$	$\overline{^6}$
					H1	H2	H4	H8	H10	H20	AM / PM	$\overline{^6}$
					m1	m2	m4	m8	m10	m20	m40	$\overline{^6}$
	s1	s2	s4	s8	s10	s20	s40	$\overline{^6}$				
	0	1	1	Real-time data 2 access (hour data to)	H1	H2	H4	H8	H10	H20	AM / PM	$\overline{^6}$
m1					m2	m4	m8	m10	m20	m40	$\overline{^6}$	
s1					s2	s4	s8	s10	s20	s40	$\overline{^6}$	
1	0	0	INT register 1 access (alarm time 1: week / hour / minute) (INT1AE = 1, INT1ME = 0, INT1FE = 0)	W1	W2	W4	$\overline{^6}$	$\overline{^6}$	$\overline{^6}$	$\overline{^6}$	A1WE	
			H1	H2	H4	H8	H10	H20	AM / PM	A1HE		
				INT register 1 access (output of user-set frequency) (INT1ME = 0, INT1FE = 1)	1 Hz	2 Hz	4 Hz	8 Hz	16 Hz	SC4 <sup>*2</sup>	SC5 <sup>*2</sup>	SC6 <sup>*2</sup>
1	0	1	INT register 2 access (alarm time 2: week / hour / minute) (INT2AE = 1)	W1	W2	W4	$\overline{^6}$	$\overline{^6}$	$\overline{^6}$	$\overline{^6}$	A2WE	
			H1	H2	H4	H8	H10	H20	AM / PM	A2HE		
1	1	0	Clock correction register access	V0	V1	V2	V3	V4	V5	V6	V7	
1	1	1	Free register access	F0	F1	F2	F3	F4	F5	F6	F7	

\*1. Write only flag. The PT7C43190 initializes by writing "1" in this register.

\*2. Scratch bit. This is a register which is available for read / write operations and can be used by users freely.

\*3. Read only flag. Valid only when use the alarm function. When the alarm time matches, this flag is set to "1", and it is cleared to "0" when reading.

\*4. Read only flag. "POC" is set to "1" when power is applied. It is cleared to "0" when reading. Regarding "BLD", refer to "*Low Power Supply Voltage Detection Circuit*".

\*5. Test bit. Be sure to set "0" in use.

\*6. No effect when writing. It is "0" when reading.

## 3. Configuration of Registers

### 3.1. Real-time Data Register

The real-time data register is a 7-byte register that stores the data of year, month, day, day of the week, hour, minute, and second in the BCD code. To write / read real-time data 1 access, transmit / receive the data of year in B7, month, day, day of the week, hour, minute, second in B0, in 7-byte. When you skip the procedure to access the data of year, month, day, day of the week, read / write real-time data 2 accesses. In this case, transmit / receive the data of hour in B7, minute, second in B0, in 3-byte.

The RTC transfers a set of data of time to the real-time data register when it recognizes the read command.

Therefore, the RTC keeps precise time even if time-carry occurs during the read operation of real-time data register.

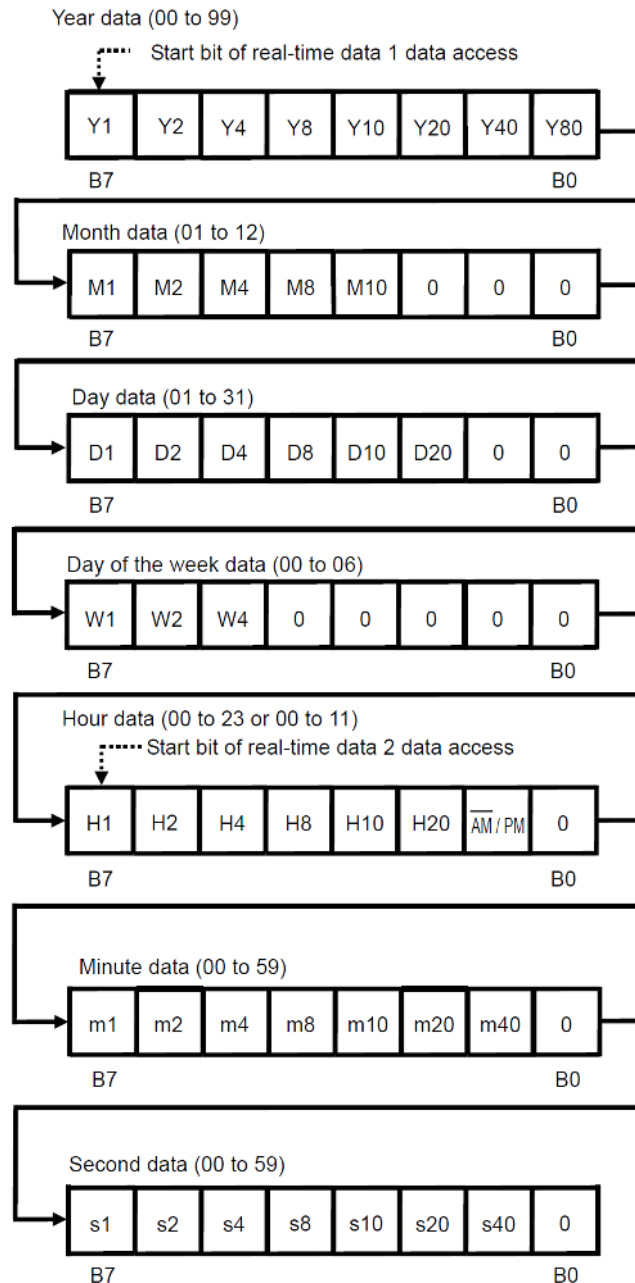

**Year data (00 to 99): Y1, Y2, Y4, Y8, Y10, Y20, Y40, Y80**

Sets the lower two digits of the Western calendar year (00 to 99) and links together with the auto calendar function until 2099.  
Example: 2053 (Y1, Y2, Y4, Y8, Y10, Y20, Y40, Y80) = (1, 1, 0, 0, 1, 0, 1, 0)

**Month data (01 to 12): M1, M2, M4, M8, M10**

Example: December (M1, M2, M4, M8, M10, 0, 0, 0) = (0, 1, 0, 0, 1, 0, 0, 0)

**Day data (01 to 31): D1, D2, D4, D8, D10, D20**

The count value is automatically changed by the auto calendar function.  
1 to 31: Jan., Mar., May, July, Aug., Oct., Dec., 1 to 30: April, June, Sep., Nov.  
1 to 29: Feb. (leap year), 1 to 28: Feb. (non-leap year)  
Example: 29 (D1, D2, D4, D8, D10, D20, 0, 0) = (1, 0, 0, 1, 0, 1, 0, 0)

**Day of the week data (00 to 06): W1, W2, W4**

Day of the week is counted in the order of 00, 01, 02, 03, 04, 05, 06, and 00. Set up day of the week and the count value.

**Hour data (00 to 23 or 00 to 11): H1, H2, H4, H8, H10, H20, AM / PM**

In 12-hour mode, write 0; AM, 1; PM in the AM / PM bit. In 24-hour mode, users can write either 0 or 1. 0 is read when the hour data is from 00 to 11, and 1 is read when from 12 to 23.

Example (12-hour mode): 11 p.m. (H1, H2, H4, H8, H10, H20, AM / PM, 0) = (1, 0, 0, 0, 1, 0, 1, 0)

Example (24-hour mode): 22 (H1, H2, H4, H8, H10, H20, AM / PM, 0) = (0, 1, 0, 0, 0, 1, 1, 0)

**Minute data (00 to 59): m1, m2, m4, m8, m10, m20, m40**

Example: 32 minutes (m1, m2, m4, m8, m10, m20, m40, 0) = (0, 1, 0, 0, 1, 1, 0, 0)

Example: 55 minutes (m1, m2, m4, m8, m10, m20, m40, 0) = (1, 0, 1, 0, 1, 0, 1, 0)

**Second data (00 to 59): s1, s2, s4, s8, s10, s20, s40**

Example: 19 seconds (s1, s2, s4, s8, s10, s20, s40, 0) = (1, 0, 0, 1, 1, 0, 0, 0)

### 3.2. Status Register 1

Status register 1 is a 1-byte register that is used to display and set various modes. The bit configuration is shown below.

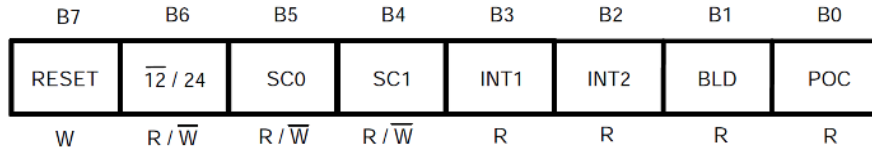

R: Read  
W: Write  
R/ $\overline{W}$ : Read / write

#### B1: BLD

This flag is set to "1" when the power supply voltage decreases to the level of detection voltage (VDET) or less. Users can detect a drop in the power supply voltage. This flag is set to "1" once, is not set to "0" again even if the power supply increases to the level of detection voltage (VDET) or more. This flag is read-only. When this flag is "1", be sure to initialize. Regarding the operation of the power supply voltage detection circuit, refer to "Low Power Supply Voltage Detection Circuit".

#### B2: INT2, B3: INT1

This flag indicates the time set by alarm and when the time has reached it. This flag is set to "1" when the time that users set by using the alarm interrupt function has come. The INT1 flag at alarm 1 interrupt mode and the INT2 flag at alarm 2 interrupt mode are set to "1". Set "0" in INT1AE (B5 in the status register 2) or in INT2AE (B1 in the status register 2) after reading "1" in the INT1 flag or in the INT2 flag. This flag is read-only. This flag is read once, is set to "0" automatically.

#### B4: SC1, B5: SC0

These flags are SRAM type registers, they are 2 bits as a whole, can be freely set by users.

#### B6: 12 / 24

This flag is used to set 12-hour or 24-hour mode. Set the flag ahead of write operation of the real-time data register in case of 24-hour mode.

0: 12-hour mode

1: 24-hour mode

#### B7: RESET

The internal IC is initialized by setting this bit to "1". This bit is write-only. It is always "0" when reading. When applying the power supply voltage to the IC, be sure to write "1" to this bit to initialize the circuit. Regarding each status of data after initialization, refer to "Register Status after Initialization".

### 3.3. Status Register 2

Status register 2 is a 1-byte register that is used to display and set various modes. The bit configuration is shown below.

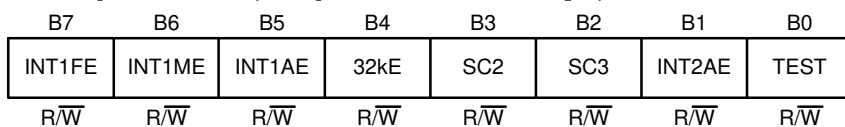

R/ $\overline{W}$  : Read/Write

#### B0: TEST

This is a test flag. Be sure to set this flag to "0" in use. If this flag is set to "1", be sure to initialize to set "0".

#### B1: INT2AE

This is an enable bit for alarm 2 interrupt. When this bit is "0", alarm 2 interrupt is disabled. When it is "1", it is enabled.

To use alarm 2 interrupt, access the INT register 2 after enabling this flag.

**Caution Note that alarm 2 interrupt is output from the INT pin regardless of the settings in flags B4 to B7.**

**B2: SC3, B3: SC2**

These are 2-bit SRAM type registers that can be freely set by users.

**B4: 32kE, B5: INT1AE, B6: INT1ME, B7: INT1FE**

These bits are used to select the output mode for the INT pin. Below **Table** shows how to select the mode. To use alarm 1 interrupt, access the INT register 1 after setting the alarm 1 interrupt mode.

**Table: Output Modes for INT Pin**

32kE	INT1AE	INT1ME	INT1FE	INT Pin Output Mode
0	0	0	0	No interrupt
0	-*1	0	1	Output of user-set frequency
0	-*1	1	0	Per-minute edge interrupt
0	0	1	1	Minute-periodical interrupt 1 (50% duty)
0	1	0	0	Alarm 1 interrupt
0	1	1	1	Minute-periodical interrupt 2
1	-*1	-*1	-*1	32.768 kHz output

\*1. Don't care (both of 0 and 1 are acceptable).

**3.4. INT Register 1 and INT Register 2**

The INT register 1 is to set up the output of user-set frequency, or to set up alarm 1 interrupt. The INT register 2 is for setting alarm 2 interrupt. Users are able to switch the output mode by using the status register 2. If selecting to use the output mode for alarm interrupt by status register 2; this register works as the alarm-time data register. In the INT register 1, if selecting the output of user-set frequency by status register 2; this register works as the data register to set the frequency for clock output. From the INT pin, a clock pulse and alarm interrupt are output, according to the or-condition that these two registers have.

**a. Alarm Interrupt**

Users can set the alarm time (the data of day of the week, hour, minute) by using the INT1 and INT2 registers which are 3-byte data registers. The configuration of register is as well as the data register of day of the week, hour, minute, in the real-time data register; is expressed by the BCD code. Do not set a nonexistent day. Users are necessary to set up the alarm-time data according to the 12 / 24 hour mode that they set by using the status register 1.

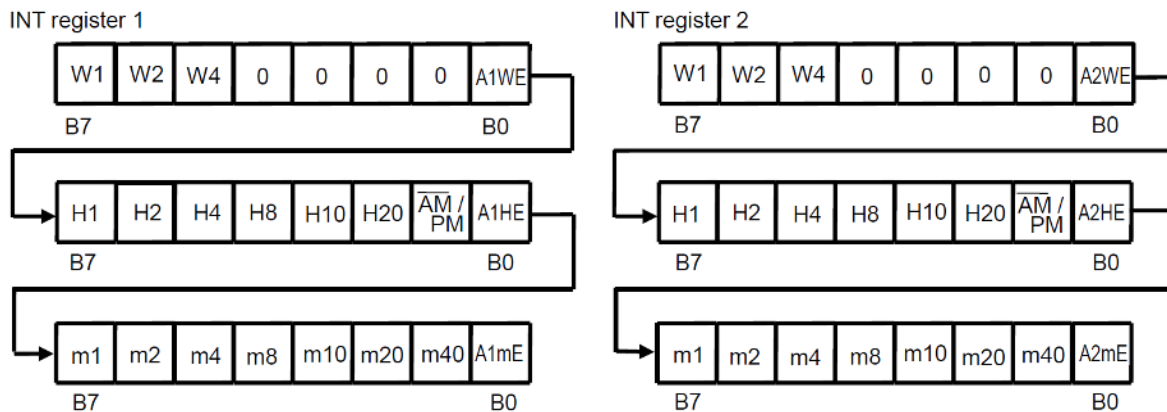

**INT Register 1 and INT Register 2 (Alarm-Time Data)**

The INT register 1 has A1WE, A1HE, and A1mE at B0 in each byte. It is possible to make data valid; the data of day of the week, hour, minute which are in the corresponded byte; by setting these bits to "1". This is as well in A2WE, A2HE, and A2mE in the INT register 2.

Setting example: alarm time "7:00 pm" in the INT register 1

**(1) 12-hour mode (status register 1 B6 = 0)**

Set up 7:00 PM

Data written to INT register 1

Day of the Week	_(*)	_(*)	_(*)	_(*)	_(*)	_(*)	_(*)	0
Hour	1	1	1	0	0	0	1	1
Minute	0	0	0	0	0	0	0	1
	B7							B0

\*1. Don't care (both of 0 and 1 are acceptable).

**(2) 24-hour mode (status register 1 B6 = 1)**

Set up 19:00 PM

Data written to INT register 1

Day of the Week	_(*)	_(*)	_(*)	_(*)	_(*)	_(*)	_(*)	0
Hour	1	0	0	1	1	0	1(*2)	1
Minute	0	0	0	0	0	0	0	1
	B7							B0

\*1. Don't care (both of 0 and 1 are acceptable).

\*2. Set up AM / PM flag along with the time setting.

**b. INT Register 1 and INT Register 2**

• **Output of user-set frequency**

The INT register 1 is a 1-byte data register to set up the output frequency. Setting each bit B7 to B3 in the register to "1", the frequency which corresponds to the bit is output in the AND-form. SC4 to SC6 is 3-bit SRAM type registers that can be freely set by users.

B7	B6	B5	B4	B3	B2	B1	B0
1Hz	2Hz	4Hz	8Hz	16Hz	SC4	SC5	SC6
R/W	R/W	R/W	R/W	R/W	R/W	R/W	R/W

**INT Register 1 (Data Register for Output Frequency)**

**Example: B7 to B3 = 50h**

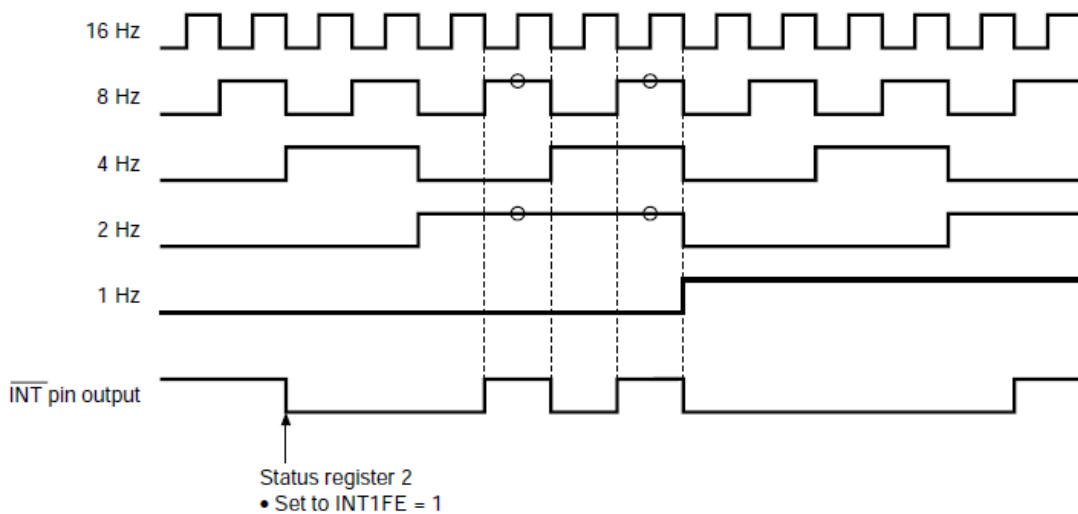

**Example of Output from INT Register 1 (Data Register for Output Frequency)**

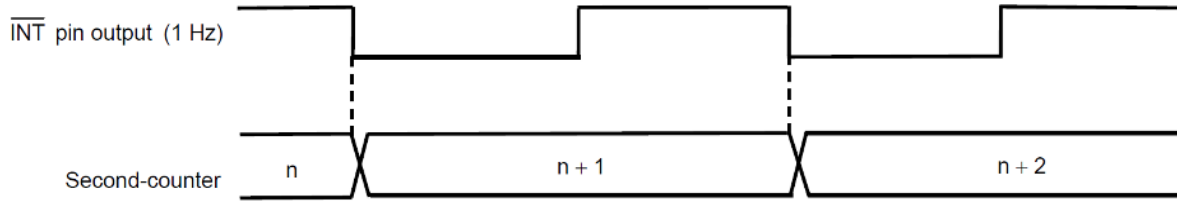

1 Hz Clock Output and Second-counter

### 3.5. Clock Correction Register

The clock correction register is a 1-byte register that is used to correct advance / delay of the clock. When not using this function, set this register to "00h". Regarding the register values, refer to "Function to Clock Correction".

B7	B6	B5	B4	B3	B2	B1	B0
V0	V1	V2	V3	V4	V5	V6	V7
R/W	R/W	R/W	R/W	R/W	R/W	R/W	R/W

R/W : Read/Write

### 3.6. Free Register

This free register is a 1-byte SRAM type register that can be set freely by users.

B7	B6	B5	B4	B3	B2	B1	B0
V0	V1	V2	V3	V4	V5	V6	V7
R/W	R/W	R/W	R/W	R/W	R/W	R/W	R/W

R/W : Read/Write

## 4. Power-on Detection Circuit and Register Status

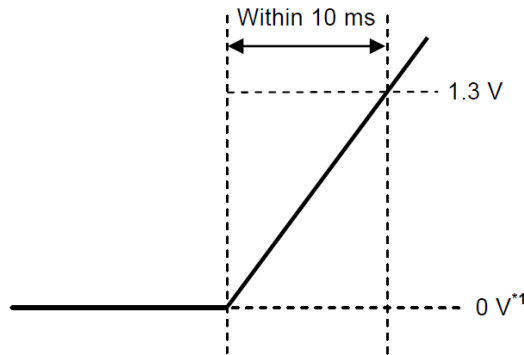

\*1. 0 V indicates that there are no potential differences between the VDD pin and VSS pin.

**How to Raise the Power Supply Voltage**

## 5. Register Status After Initialization

The status of each register after initialization is as follows.

Real-time data register: 00 (Y), 01 (M), 01 (D), 0 (day of the week), 00 (H), 00 (M), 00 (S)

Status register 1: "0 B6 B5 B4 0 0 0 0 b"

(In B6, B5, B4, the data of B6, B5, B6 in the status register 1 at initialization is set. Refer to below Figure.)

Status register 2: "00h"

INT1 register: "00h"

INT2 register: "00h"

Clock correction register: "00h"

Free register: "00h"

• **Status Register 1 Data at Initialization**

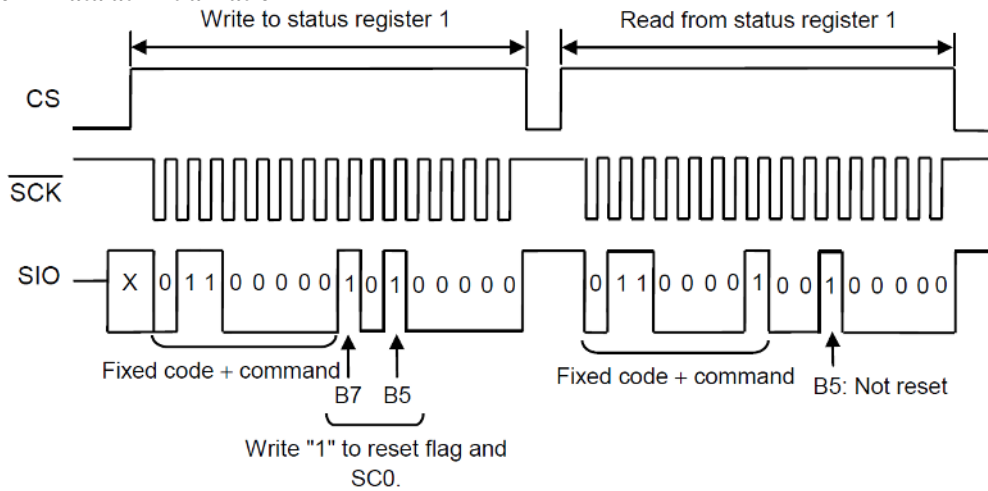

**6. Low Power Supply Voltage Detection Circuit**

The RTC has a low power supply voltage detection circuit, so that users can monitor drops in the power supply voltage by reading the BLD flag (B1 in the status register 1). There is a hysteresis width of approx. 0.15 V (typ.) between detection voltage and release voltage (refer to "Characteristics (Typical Data)"). The low power supply voltage detection circuit does the sampling operation only once in one sec for 15.6 ms. If the power supply voltage decreases to the level of detection voltage (VDET) or less, "1" is set to the BLD flag so that sampling operation stops. Once "1" is detected in the BLD flag, no sampling operation is performed even if the power supply voltage increases to the level of release voltage or more, and "1" is held in the BLD flag. If the BLD flag is "1" even after the power supply voltage is recovered, the internal circuit may be in the indefinite status. In this case, be sure to initialize the circuit. After reading the BLD flag, the sampling operation is restarted. Without initializing, if the next BLD flag reading is done after sampling, the BLD flag gets reset to "0". In this case, be sure to initialize although the BLD flag is in "0" because the internal circuit may be in the indefinite status.

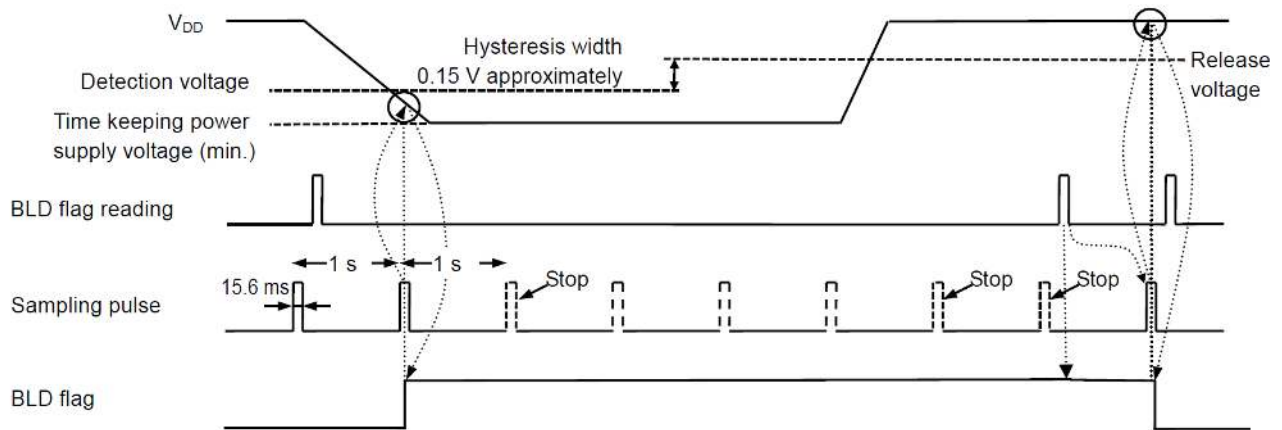

**Timing of Low Power Supply Voltage Detection Circuit**

### 7. Circuits Power-on and Low Power Supply Voltage Detection

Below Figure shows the changes of the POC flag and BLD flag due to VDD fluctuation.

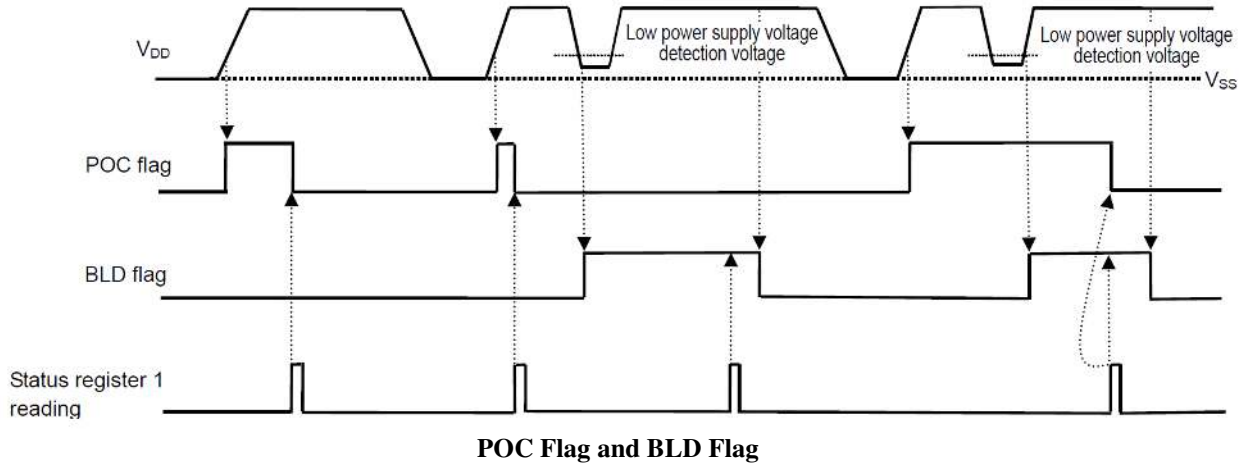

### 8. Nonexistent Data and End-of-Month

When users write the real-time data, the RTC checks it. In case that the data is invalid, the RTC does the following procedures.

- Processing of nonexistent data**

Register	Normal Data	Nonexistent Data	Result	
Year data	00 to 99	XA to XF, AX to FX	00	
Month data	01 to 12	00, 13 to 19, XA to XF	01	
Day data	01 to 31	00, 32 to 39, XA to XF	01	
Day of the week data	0 to 6	7	0	
Hour data <sup>*1</sup>	24-hour	0 to 23	24 to 29, 3X, XA to XF	00
	12-hour	0 to 11	12 to 20, XA to XF	00
Minute data	00 to 59	60 to 79, XA to XF	00	
Second data <sup>*2</sup>	00 to 59	60 to 79, XA to XF	00	

\*1. In 12-hour mode, write the AM / PM flag (B1 in hour data in the real-time data register). In 24-hour expression, the AM / PM flag in the real-time data register is omitted. However in the flag of reading, users are able to read 0; 0 to 11, 1; 12 to 23.

\*2. Processing of nonexistent data, regarding second data, is done by a carry pulse which is generated in 1 second, after writing. At this point the carry pulse is sent to the minute-counter.

- Correction of end-of-month**

A nonexistent day, such as February 30 and April 31, is set to the first day of the next month.



## 9. Alarm and Interrupt Output

### 9.1. INT Pin Output Mode

These are selectable for the INT pin output mode;

Alarm 1 interrupt, alarm 2 interrupt, the output of user-set frequency, per-minute edge interrupt output, and minute-periodical interrupt output 1 and 2, 32.768 kHz output. In alarm 1 interrupt / output of frequency; set data in the INT register 1. In alarm 2 interrupt, set data in the INT register 2. To switch the output mode, use the status register 2. Refer to "Status register 2" in "Configuration of Registers". When switching the output mode, be careful of the output status of the pin. Especially, when using alarm interrupt / output of frequency, switch the output mode after setting "00h" in the INT register 1 or 2. Alarm 2 interrupt is dependent from other modes. Regardless of other settings of mode if alarm 2 interrupt was generated, be careful that "L" is output from the INT pin. In 32.768 kHz output / per-minute edge interrupt output / minute-periodical interrupt output, it is unnecessary to set data in the INT register 1 or 2 for users. Refer to the followings regarding each operation of output modes.

#### a. Alarm Interrupt Output

Alarm interrupt output is the function to output "L" from the INT pin, at the alarm time which is set by user has come. If setting the pin output to "H", turn off the alarm function by setting "0" in INT1AE / INT2AE in the status register 2. To set the alarm time, set the data of day of the week, hour, minute in the INT register 1 or 2, set the data of year, month, day in the INT register 1 or 2. Refer to "INT register 1 and INT register 2" in "Configuration of Register".

##### • Alarm setting of "W (day of the week), H (hour), m (minute)"

- |                               |                                  |
|-------------------------------|----------------------------------|
| Status register 2 setting     | INT register x alarm enable flag |
| • Alarm 1 interrupt           | • AxHE = AxmE = AxWE = "1"       |
| 32kE = 0, INT1ME = INT1FE = 0 |                                  |
| • Alarm 2 interrupt           |                                  |
| None                          |                                  |

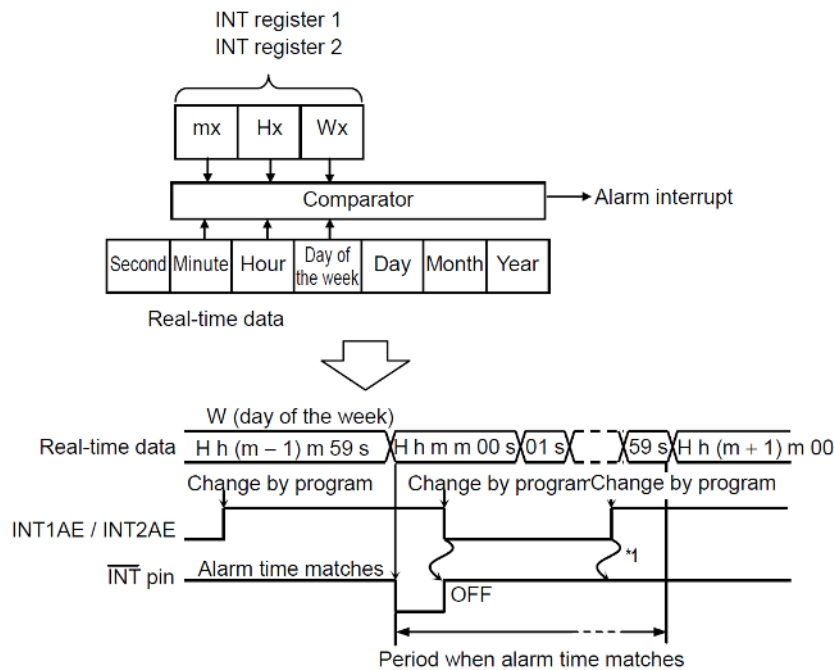

\*1. If users clear INT1AE / INT2AE once; "L" is not output from the INT pin by setting INT1AE / INT2AE enable again, within a period when the alarm time matches real-time data.

#### Alarm Interrupt Output Timing

**Alarm setting of "H (hour)"**

Status register 2 setting

- Alarm 1 interrupt  
32kE = 0, INT1ME = INT1FE = 0
- Alarm 2 interrupt  
None

INT register x alarm enable flag

- AxWE = AxmE = "0", AxHE = "1"

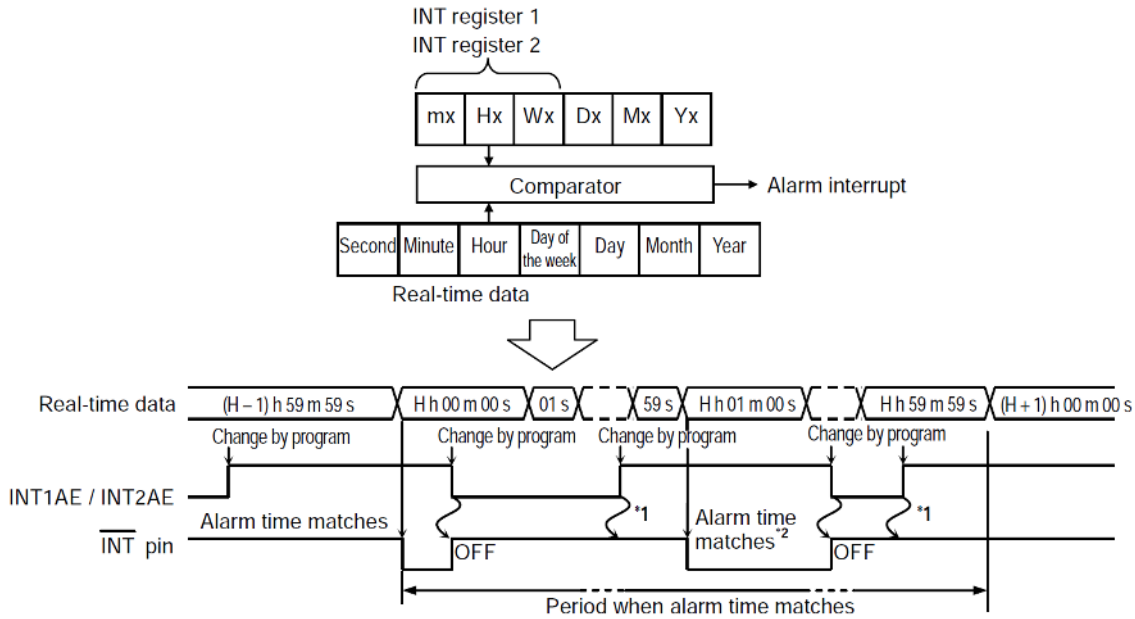

\*1. If users clear INT1AE / INT2AE once; "L" is not output from the INT pin by setting INT1AE / INT2AE enable again, within a period when the alarm time matches real-time data.

\*2. If turning the alarm output on by changing the program, within the period when the alarm time matches real-time data, "L" is output again from the INT pin when the minute is counted up.

**Alarm Interrupt Output Timing**

**b. Output of user-set Frequency**

The output of user-set frequency is the function to output the frequency which is selected by using data, from the INT pin, in the AND-form. Set up the data of frequency in the INT register 1.

Status register 2 setting

32kE = 0, INT1AE = Don't care (0 or 1), INT1ME = 0

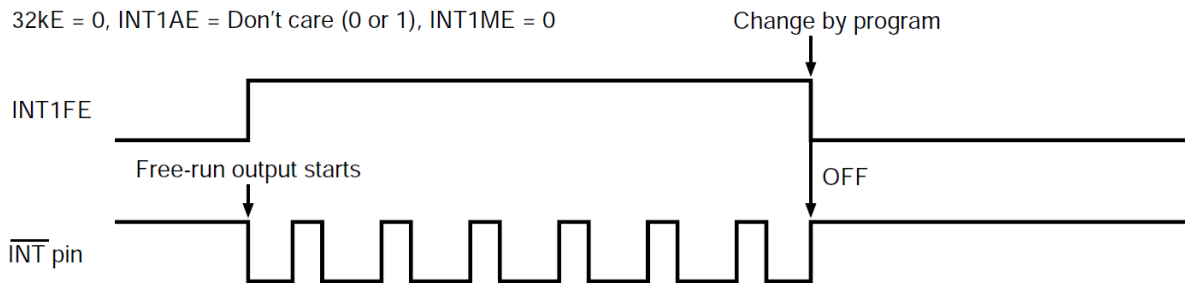

**Output Timing of User-set Frequency**

**c. Per-minute Edge Interrupt Output**

Per-minute edge interrupt output is the function to output "L" from the INT pin, when the first minute-carry processing is done, after selecting the output mode. To set the pin output to "H", set "0" in INT1ME in the status register 2 to turn off the output mode of per-minute edge interrupt.

Status register 2 setting

- 32kE = 0, INT1AE = Don't care (0 or 1), INT1FE = 0

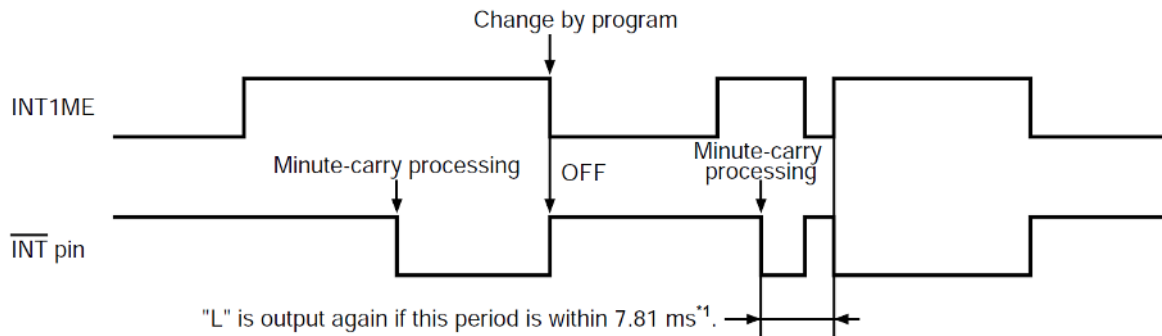

\*1. Pin output is set to "H" by disabling the output mode within 7.81 ms, because the signal of this procedure is maintained for 7.81ms. Note that pin output is set to "L" by setting enable the output mode again.

### Timing of Per-Minute Edge Interrupt Output

#### d. Minute-periodical Interrupt Output 1

The minute-periodical interrupt 1 is the function to output the one-minute clock pulse (Duty 50%) from the INT pin, when the first minute-carry processing is done, after selecting the output mode.

Status register 2 setting

- 32kE = 0, INT1AE = 0

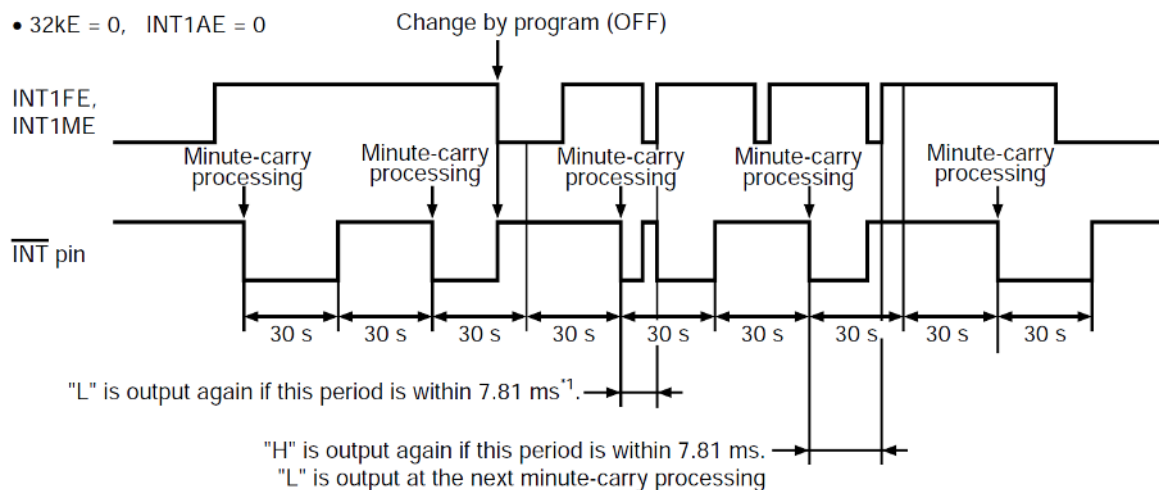

\*1. Setting the output mode disable makes the pin output "H", while the output from the INT pin is in "L". Note that pin output is set to "L" by setting enable the output mode again.

### Timing of Minute-periodical Interrupt Output 1

#### e. Minute-periodical Interrupt Output 2

The output of minute-periodical interrupt 2 is the function to output "L", for 7.81 ms, from the INT pin, synchronizing with the first minute-carry processing after selecting the output mode. However, during reading in the real-time data register, the procedure delays at max. 0.5 seconds thus output "L" from the INT pin also delays at max. 0.5 seconds during writing in the real-time data register, some delay is made in the output period due to write timing and the second-data during writing.

- During normal operation

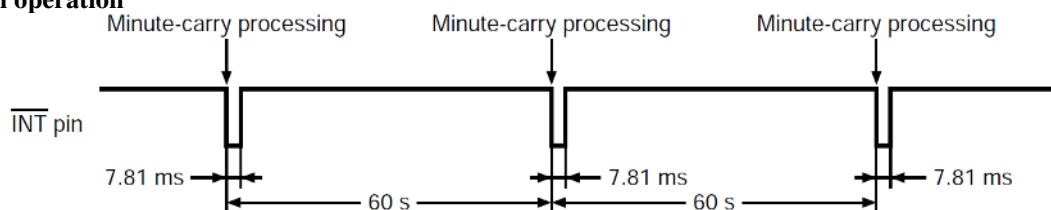

• **During reading in the real-time data register**

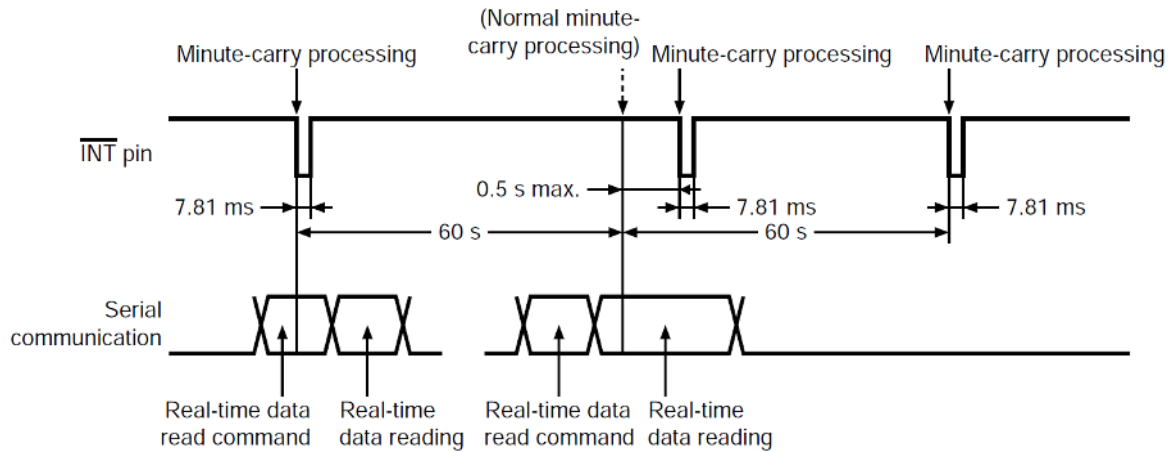

• **During writing in the real-time data register**

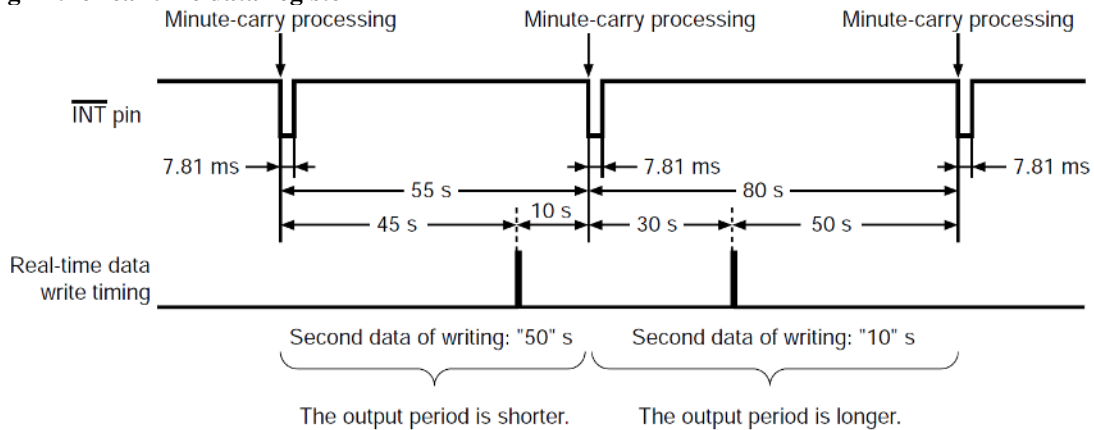

**Timing of Minute-periodical Interrupt Output 2**

**f. Operation of power-on Detection Circuit**

When power is applied to the RTC, the power-on detection operates to set "1" in the POC flag (B0 in the status register 1).

A 1 Hz clock pulse is output from the INT pin.

Status register 2 setting

32KE = 0, INT1AE = INT1ME = 0,

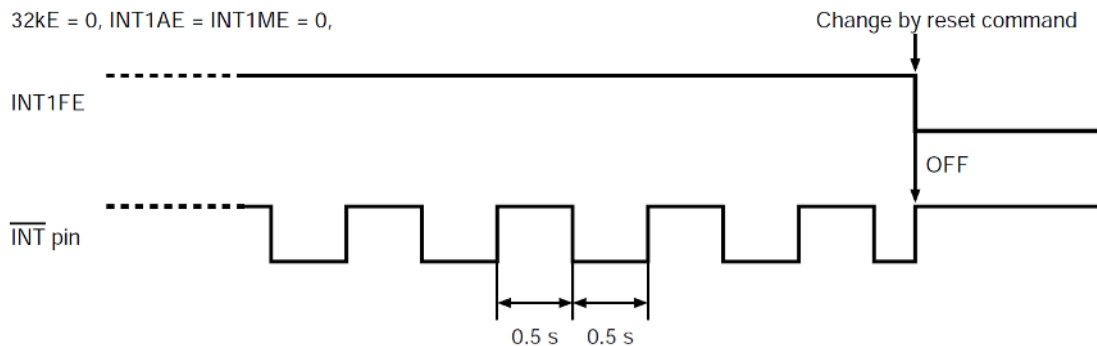

**9.2. Alarm 1 Function and INT2 Pin Output Mode**

In the output mode for INT2 pin, users are able to select the output; alarm 2 interrupt, user-set frequency, per-minute edge interrupt, minute-periodical interrupt. To switch the output mode for INT2 pin and the alarm 1 function, use the status register 2. Refer to "Status register 2" in "Configuration of Registers". When switching the output mode for INT2 pin, be careful of the output status of the pin. Especially, when using alarm 2 interrupt output, or the output of user-set frequency, switch the output mode after setting "00h" in the INT2 register. In per-minute edge interrupt output / minute-periodical interrupt output, it is unnecessary to set data in the INT2 register for users. Refer to the followings regarding each operation of output modes.

**a. Alarm 1 function and Alarm 2 Interrupt**

Alarm 2 interrupt output is the function to set the INT2 flag "H" by the output "L" from the INT2 pin, at the alarm time which is

set by user has come. If setting the pin output to "H", turn off the alarm function by setting "0" in INT2AE in the status register 2. By reading, the INT2 flag is once cleared automatically. In the alarm 1 function, the INT1 flag (B3 in the status register 1) is set to "H" when the set time has come. The INT1 flag is also cleared once by reading. In the alarm 1 function, set the data of day of the week, hour, minute of the alarm time in the INT1 register. In alarm 2 interrupt, set in the INT2 register.

**1) Alarm setting of "W (day of the week), H (hour), m (minute)"**

- Status register 2 setting
- Alarm 1 function  
INT1ME = INT1FE = 0
  - Alarm 2 interrupt  
INT2ME = INT2FE = 0

- INTx register alarm enable flag
- AxHE = AxmE = AxWE = "1"

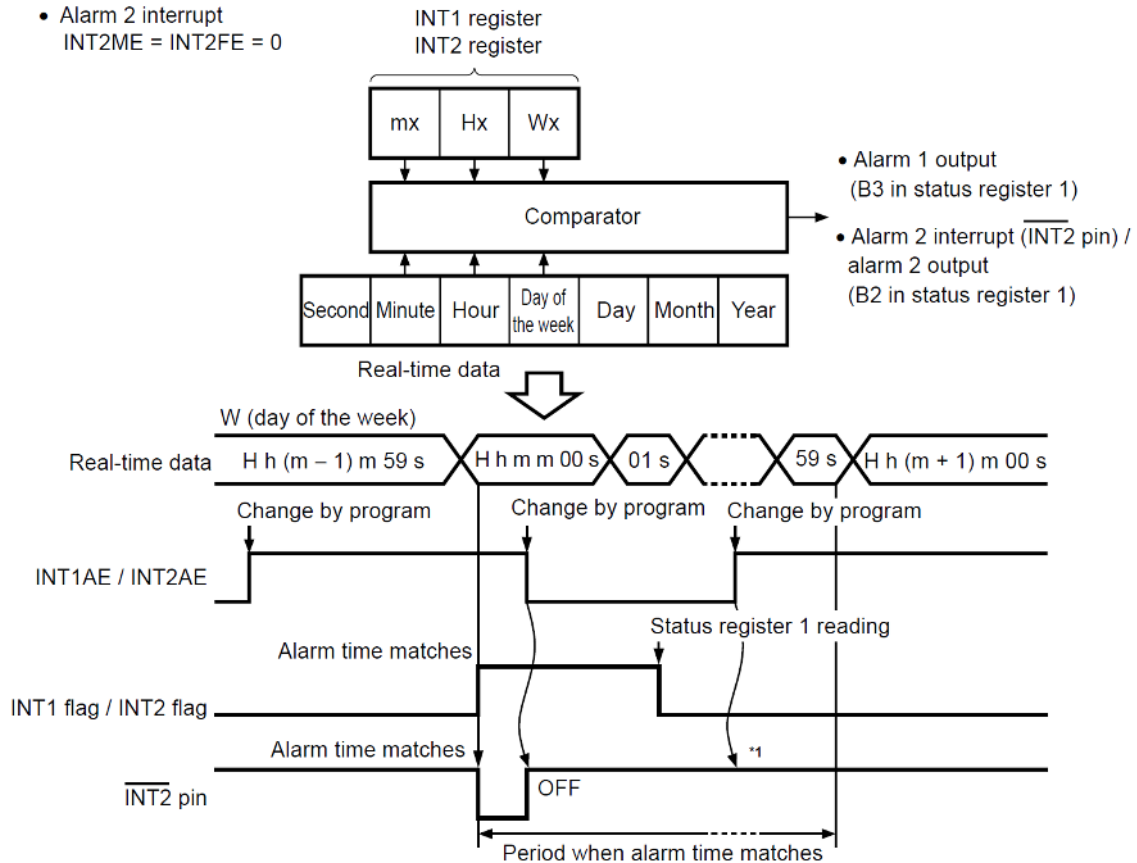

\*1. If users clear INT2AE once; "L" is not output from the INT2 pin by setting INT2AE enable again, within a period when the alarm time matches real-time data.

**Alarm Interrupt Output Timing**

**2) Alarm setting of "H (hour)"**

- Status register 2 setting
- Alarm 1 function  
INT1ME = INT1FE = 0
  - Alarm 2 interrupt  
INT2ME = INT2FE = 0

- INTx register alarm enable flag
- AxmE = AxWE = "0", AxHE = "1"

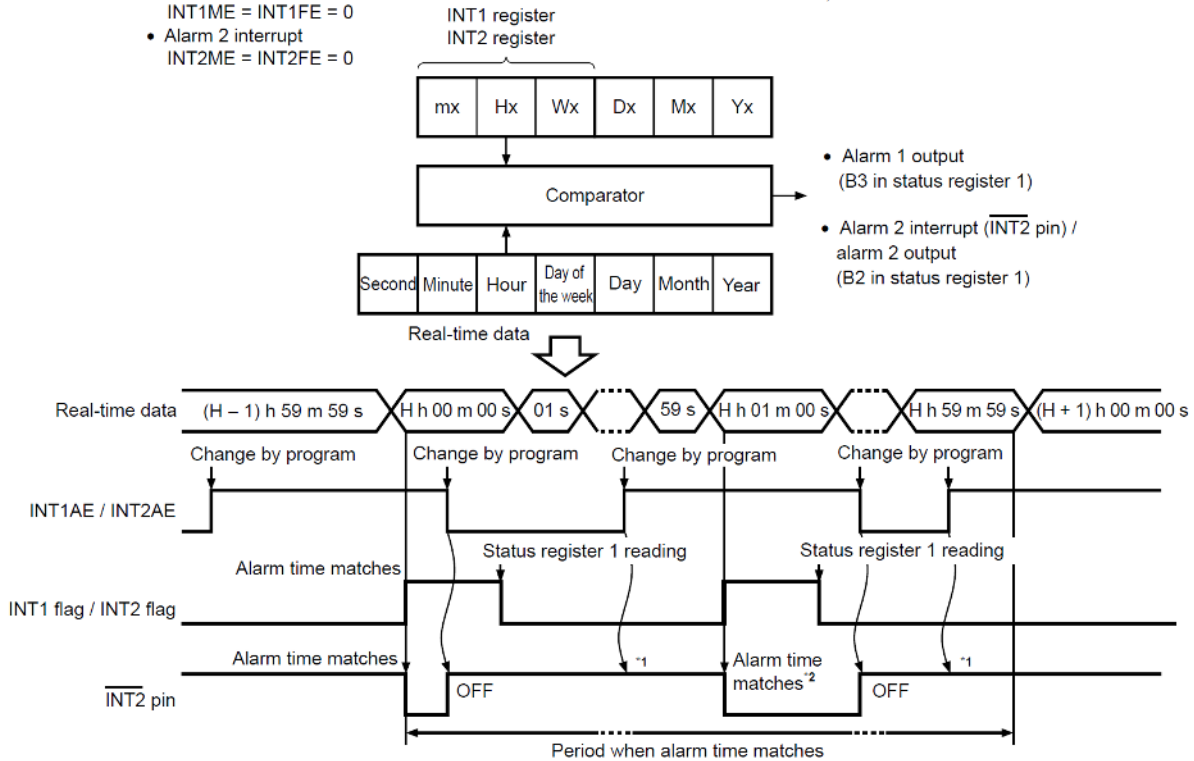

\*1. If users clear INT2AE once; "L" is not output from the INT2 pin by setting INT2AE enable again, within a period when the alarm time matches real-time data.  
\*2. If turning the alarm output on by changing the program, within the period when the alarm time matches real-time data, "L" is output again from the INT2 pin when the minute is counted up.

**Alarm Interrupt Output Timing**

**b. Output of user-set Frequency**

The output of user-set frequency is the function to output the frequency which is selected by using data, from the INT2 pin, in the AND-form. Set up the data of frequency in the INT2 register. Refer to "INT1 register and INT2 register" in "Configuration of Registers".

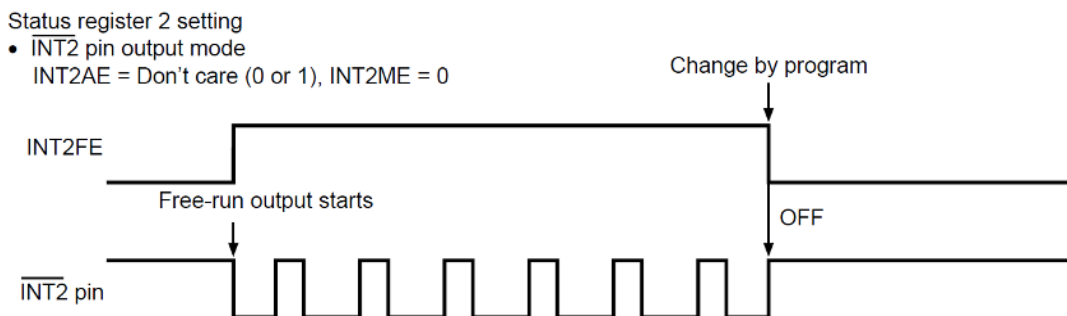

**Output Timing of User-set Frequency**

**c. Per-minute Edge Interrupt Output**

Per-minute edge interrupt output is the function to output "L" from the INT2 pin, when the first minute-carry processing is done, after selecting the output mode. To set the pin output to "H", in the INT2 pin output mode, input "0" in INT2ME in the status register 2 in order to turn off this mode.

- Status register 2 setting
- INT2 pin output mode  
INT2AE = Don't care (0 or 1), INT2FE = 0

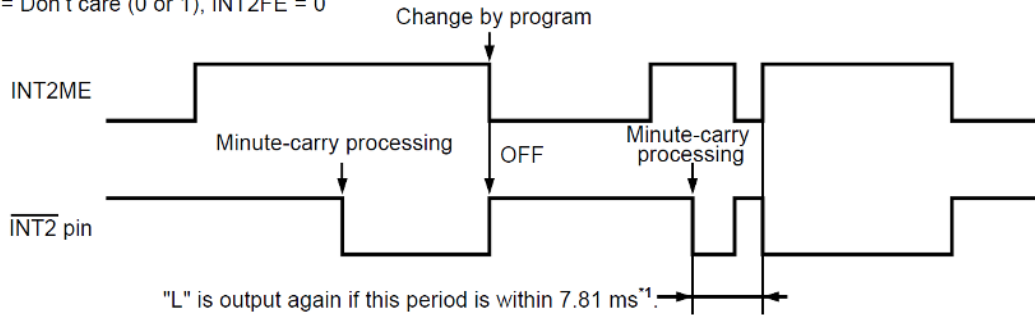

\*1. Pin output is set to "H" by disabling the output mode within 7.81 ms, because the signal of this procedure is maintained for 7.81 ms. Note that pin output is set to "L" by setting enable the output mode again.

**Timing of Per-minute Edge Interrupt Output**

**d. Minute-periodical Interrupt Output 1**

The minute-periodical interrupt 1 is the function to output the one-minute clock pulse (Duty 50%) from the INT2 pin, when the first minute-carry processing is done, after selecting the output mode.

- Status register 2 setting
- INT2 pin output mode  
INT2AE = 0

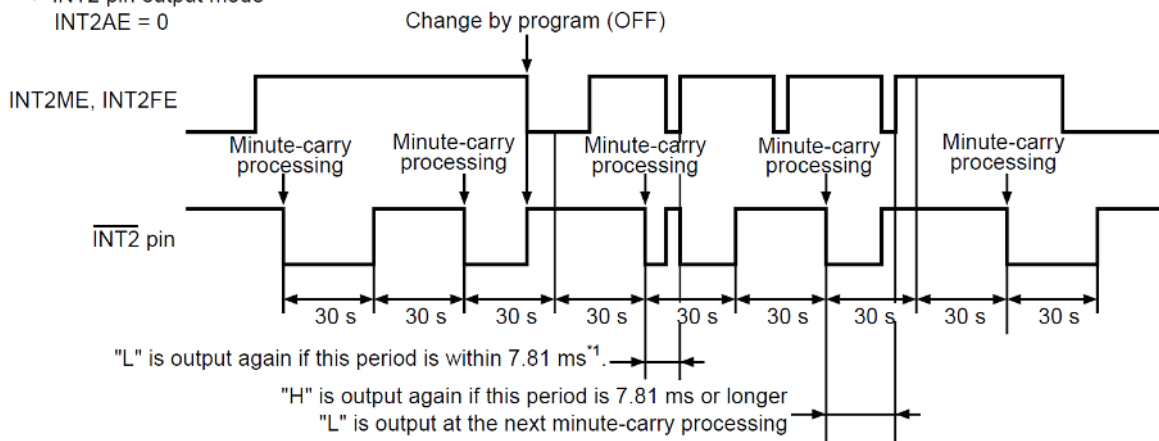

\*1. Setting the output mode disable makes the pin output "H", while the output from the INT2 pin is in "L". Note that pin output is set to "L" by setting enable the output mode again.

**Timing of Minute-periodical Interrupt Output 1**

**10. Function to Clock Correction**

The function to clock correction is to correct advance / delay of the clock due to the deviation of oscillation frequency, in order to make a high precise clock. For correction, the RTC adjusts the clock pulse by using a certain part of the dividing circuit, not adjusting the frequency of the crystal oscillator. Correction is performed once every 20 seconds (or 60 seconds). The minimum resolution is approx. 3 ppm (or approx. 1 ppm) and the RTC corrects in the range of -195.3 ppm to 192.2 ppm (or of -65.1 ppm to 64.1 ppm). Users can set up this function by using the clock correction register. Regarding how to calculate the setting data, refer to "15.2. How to calculate". When not using this function, be sure to set "00h".

**Function to Clock Correction**

Item	B0 = 0	B0 = 1
Correction	Every 20 seconds	Every 60 seconds
Minimum resolution	3.052 ppm	1.017 ppm
Correction range	-195.3 ppm to +192.2 ppm	-65.1 ppm to +64.1 ppm

### 10.1. Setting Values for Registers and Correction Values

Setting Values for Registers and Correction Values (Minimum Resolution: 3.052 ppm (B0 = 0))

B7	B6	B5	B4	B3	B2	B1	B0	Correction Value [ppm]	Rate [s / day]
1	1	1	1	1	1	0	0	192.3	16.61
0	1	1	1	1	1	0	0	189.2	16.35
1	0	1	1	1	1	0	0	186.2	16.09
•								•	•
•								•	•
•								•	•
0	1	0	0	0	0	0	0	6.1	0.53
1	0	0	0	0	0	0	0	3.1	0.26
0	0	0	0	0	0	0	0	0	0
1	1	1	1	1	1	1	0	-3.1	-0.26
0	1	1	1	1	1	1	0	-6.1	-0.53
1	0	1	1	1	1	1	0	-9.2	-0.79
•								•	•
•								•	•
•								•	•
0	1	0	0	0	0	1	0	-189.2	-16.35
1	0	0	0	0	0	1	0	-192.3	-16.61
0	0	0	0	0	0	1	0	-195.3	-16.88

Setting Values for Registers and Correction Values (Minimum Resolution: 1.017 ppm (B0 = 1))

B7	B6	B5	B4	B3	B2	B1	B0	Correction Value [ppm]	Rate [s / day]
1	1	1	1	1	1	0	1	64.1	5.54
0	1	1	1	1	1	0	1	63.1	5.45
1	0	1	1	1	1	0	1	62.0	5.36
•								•	•
•								•	•
•								•	•
0	1	0	0	0	0	0	1	2.0	0.18
1	0	0	0	0	0	0	1	1.0	0.09
0	0	0	0	0	0	0	1	0	0
1	1	1	1	1	1	1	1	-1.0	-0.09
0	1	1	1	1	1	1	1	-2.0	-0.18
1	0	1	1	1	1	1	1	-3.0	-0.26
•								•	•
•								•	•
•								•	•
0	1	0	0	0	0	1	1	-63.1	-5.45
1	0	0	0	0	0	1	1	-64.1	-5.54
0	0	0	0	0	0	1	1	-65.1	-5.62



## 10.2. How to Calculate

### a. If current oscillation frequency > target frequency (in case the clock is fast)

$$\text{Correction value}^{*1} = 128 - \text{Integral value} \left( \frac{(\text{Current oscillation frequency actual measurement value}^{*2}) - (\text{Target oscillation frequency}^{*3})}{(\text{Current oscillation frequency actual measurement value}^{*2}) \times (\text{Minimum resolution}^{*4})} \right)$$

**Caution** The figure range which can be corrected is that the calculated value is from 0 to 64.

\*1. Convert this value to be set in the clock correction register. For how to convert, refer to "Calculation example 1".

\*2. Measurement value when 1 Hz clock pulse is output from the INT pin.

\*3. Target value of average frequency when the clock correction function is used.

\*4. Refer to "Function to Clock Correction".

#### • Calculation example 1

In case of current oscillation frequency actual measurement value = 1.000070 [Hz], target oscillation frequency = 1.000000 [Hz], B0 = 0 (Minimum resolution = 3.052 ppm)

$$\begin{aligned} \text{Correction value} &= 128 - \text{Integral value} \left( \frac{(1.000070) - (1.000000)}{(1.000070) \times (3.052 \times 10^{-6})} \right) \\ &= 128 - \text{Integral value} (22.93) = 128 - 22 = 106 \end{aligned}$$

Convert the correction value "106" to 7-bit binary and obtain "1101010b".

Reverse the correction value "1101010b" and set it to B7 to B1 of the clock correction register.

Thus, set the clock correction register:

$$(B7, B6, B5, B4, B3, B2, B1, B0) = (0, 1, 0, 1, 0, 1, 1, 0)$$

### b. If current oscillation frequency < target frequency (in case the clock is fast)

$$\text{Correction value} = \text{Integral value} \left( \frac{(\text{Target oscillation frequency}) - (\text{Current oscillation frequency actual measurement value})}{(\text{Current oscillation frequency actual measurement value}) \times (\text{Minimum resolution})} \right) + 1$$

**Caution** The figure range which can be corrected is that the calculated value is from 0 to 62.

#### • Calculation example 2

In case of current oscillation frequency actual measurement value = 0.999920 [Hz], target oscillation frequency = 1.000000 [Hz], B0 = 0 (Minimum resolution = 3.052 ppm)

$$\begin{aligned} \text{Correction value} &= \text{Integral value} \left( \frac{(1.000000) - (0.999920)}{(0.999920) \times (3.052 \times 10^{-6})} \right) + 1 \\ &= \text{Integral value} (26.21) + 1 = 26 + 1 = 27 \end{aligned}$$

Thus, set the clock correction register:

$$(B7, B6, B5, B4, B3, B2, B1, B0) = (1, 1, 0, 1, 1, 0, 0, 0)$$

#### • Calculation example 3

In case of current oscillation frequency actual measurement value = 0.999920 [Hz], target oscillation frequency = 1.000000 [Hz], B0 = 1 (Minimum resolution = 1.017 ppm)

$$\begin{aligned} \text{Correction value} &= \text{Integral value} \left( \frac{(1.000000) - (0.999920)}{(0.999920) \times (1.017 \times 10^{-6})} \right) + 1 \\ &= \text{Integral value} (78.66) + 1 \end{aligned}$$

This calculated value exceeds the correctable range 0 to 62.

B0 = "1" (minimum resolution = 1.017 ppm) indicates the correction is impossible.

**10.3. How to Confirm a Setting Value for a Register and the Result of Correction**

This RTC does not adjust the frequency of the crystal oscillation by using the function of clock correction. Therefore users cannot confirm if it is corrected or not by measuring output 32.768 kHz. When the function of clock correction is being used, the cycle of 1 Hz clock pulse output from the INT pin changes once in 20 times or 60 times, as shown in below figure.

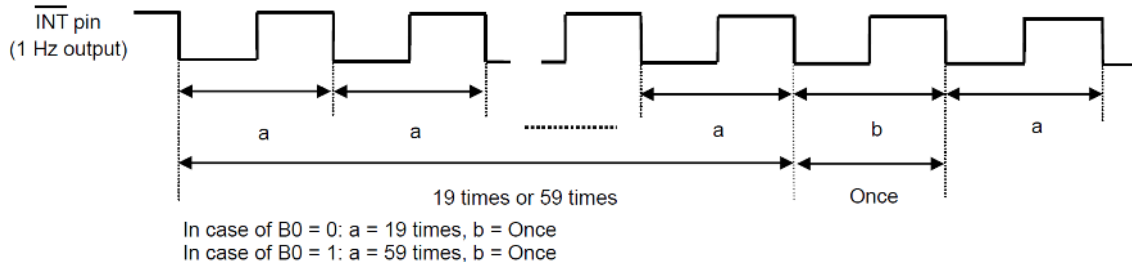

**Confirmation of the clock correction**

Measure a and b by using the frequency counter\*1. Calculate the average frequency (Tave) based on the measurement results.

B0 = 0, Tave = (a     19 + b)     20

B0 = 1, Tave = (a     59 + b)     60

Calculate the error of the clock based on the average frequency (Tave). The following shows an example for confirmation.

Confirmation example: When B0 =0, 66h is set

Measurement results: a = 1.000080 Hz, b = 0.998493 Hz

Clock Correction Register Setting Value		Average frequency [Hz]	Per Day [s]
Before correction	00 h (Tave = a)	1.000080	86393
After correction	66 h (Tave = (a × 19 + b) ÷ 20)	1.00000065	86399.9

Calculating the average frequency allows to confirm the result of correction.

\*1. Use a high-accuracy frequency counter of 7 digits or more.

**Caution Measure the oscillation frequency under the usage conditions.**

**11. Serial Interface**

**11.1. 3-wire Serial Interface**

The PT7C43190 receives various commands via 3-wire serial interface to read / write data. Regarding transmission is as follows.

**a. Data Reading**

When data is input from the SIO pin in synchronization with the falling of the SCK clock after setting the CS pin to "H", the data is loaded internally in synchronization with the next rising of the SCK clock. When R / W bit = "1" is loaded at the eighth rising of the SCK clock, the state of data reading is entered. Data corresponding to each command is then output in synchronization with the falling of the subsequent SCK clock input. When the SCK clock is less than 8, the IC is in the clock-wait status, and no processing is performed.

**b. Data Writing**

When data is input from the SIO pin in synchronization with the falling of the SCK clock after setting the CS pin to "H", the data is loaded internally in synchronization with the next rising of the SCK clock. When R / W bit = "0" is loaded at the eighth rising of the SCK clock, the state of data writing is entered. In this state, the data, which is input in synchronization with the falling of the subsequent SCK clock input, is written to registers according to each command. In data writing, input a clock pulse which is equivalent to the byte of the register. As well as reading, when the SCK clock is less than 8, the IC is in the clock-wait status, and no processing is performed.

**c. Data Access**

**• Real-time data 1 access**

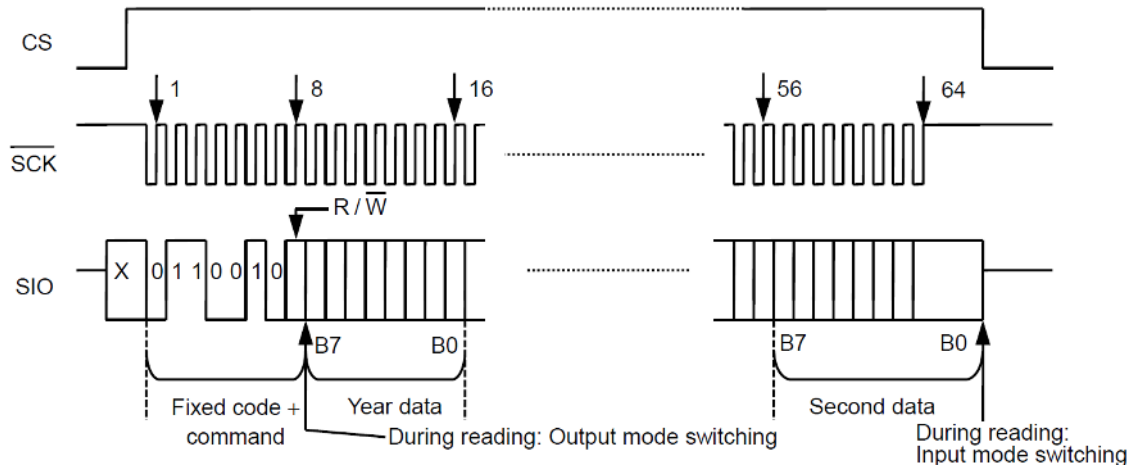

**Real-time data 1 access**

**• Real-time data 2 access**

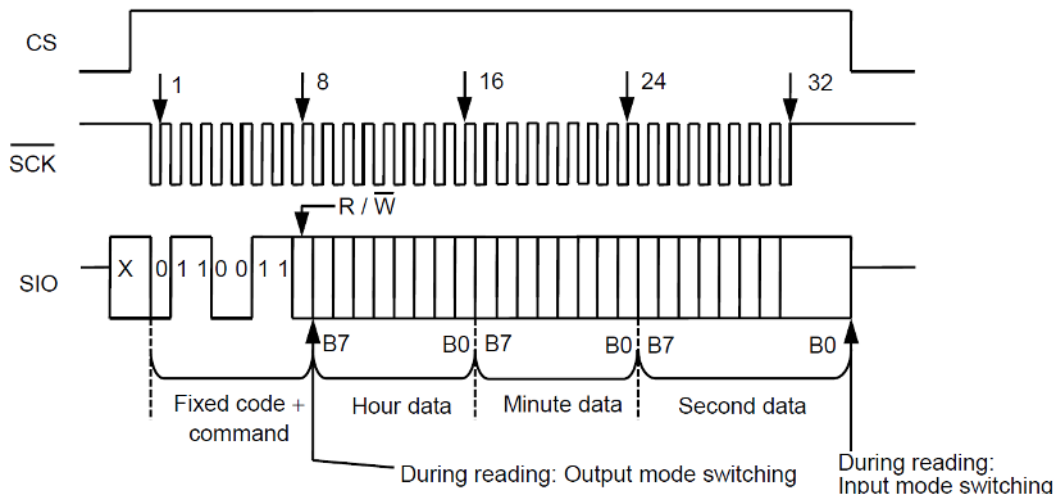

**Real-time Data 2 Access**

**• Status register 1 access and status register 2 access**

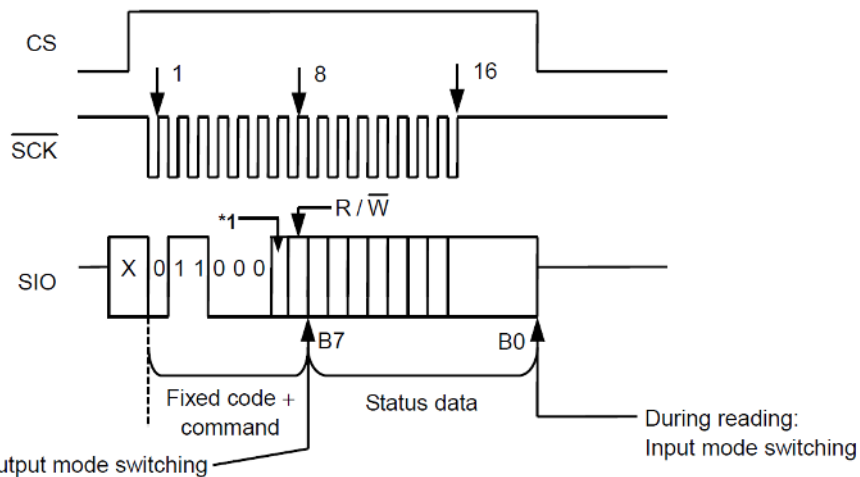

\*1. 0: Status register 1 selected  
1: Status register 2 selected

**Status Register 1 Access and Status Register 2 Access**

**• INT register 1 access and INT register 2 access**

In read / write the INT register 1, data varies depending on the setting of the status register 2. Be sure to read / write the INT register 1 after setting the status register 2. When setting the alarm by using the status register 2, these registers work as 3-byte

alarm time data registers, in other statuses, they work as 1-byte registers. When outputting the user-set frequency, they are the data registers to set up the frequency. Read / write the INT register 2 after setting INT2AE in the status register 2. When INT2AE is in "1", the INT register 2 works as for setting the 3-byte alarm time data. The INT register 2 does not have the function to output the user-set frequency. Regarding details of each data, refer to "INT register 1 and INT register 2" in "Configuration of Register".

**Caution Users cannot use both functions of alarm 1 interrupt and the output of user-set frequency simultaneously.**

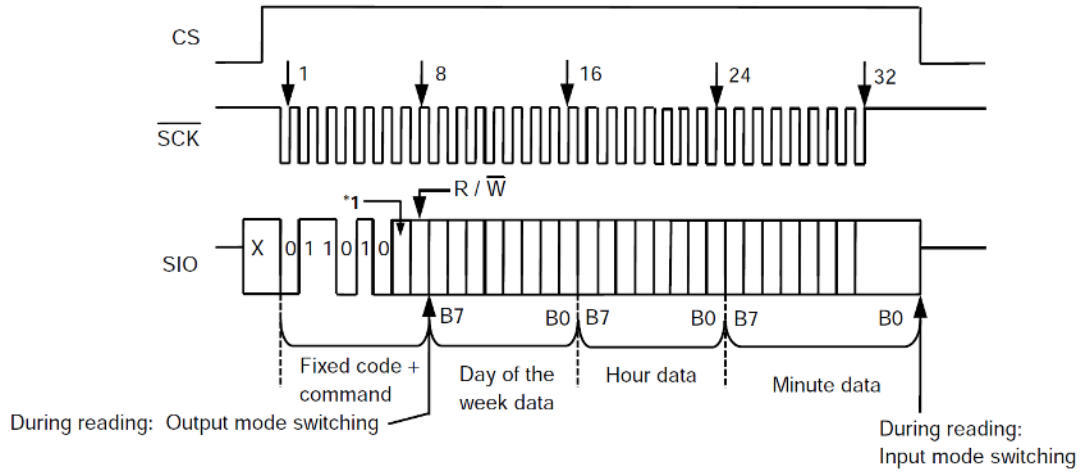

- \*1. 0: Status register 1 selected
- 1: Status register 2 selected

**INT Register 1 Access and INT Register 2 Access**

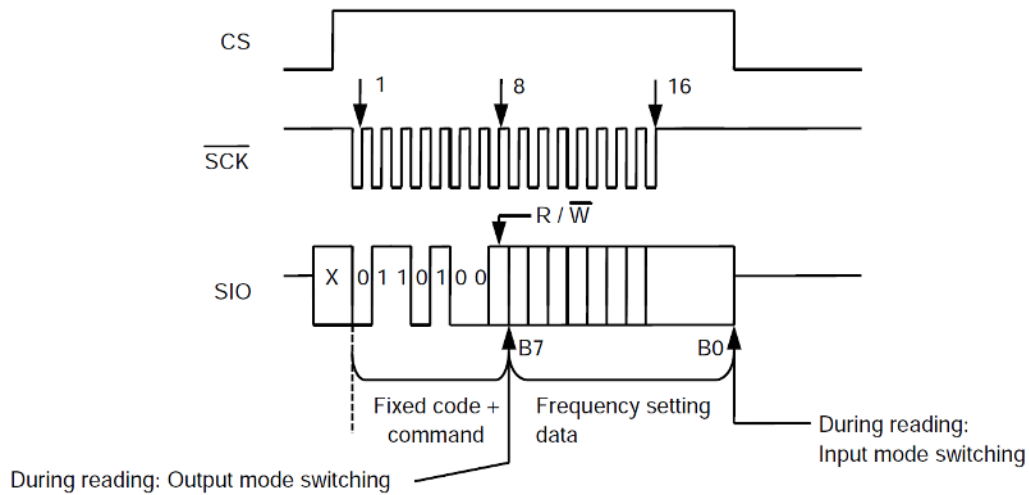

**INT Register 1 (Data Register for output frequency) Access**

• **Clock correction register access**

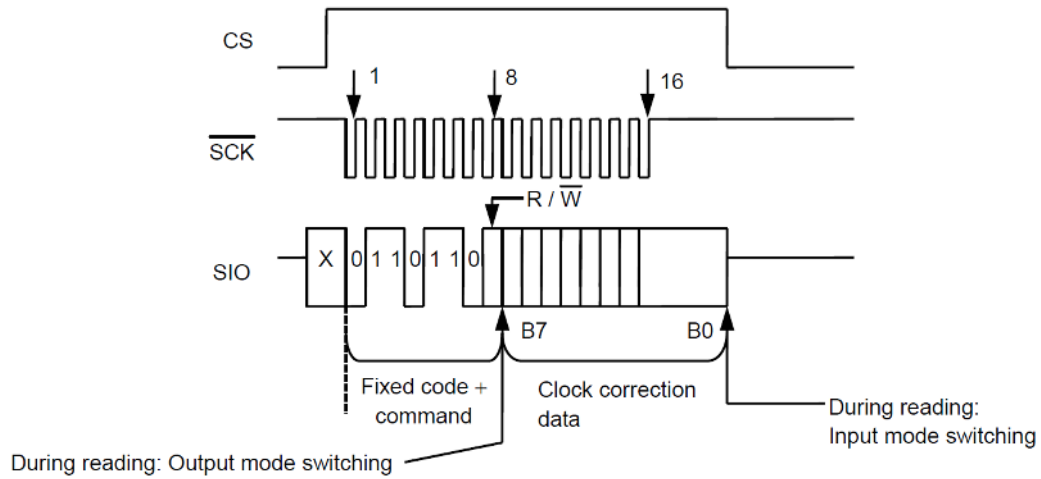

**Clock Correction Register Access**

• **Free register access**

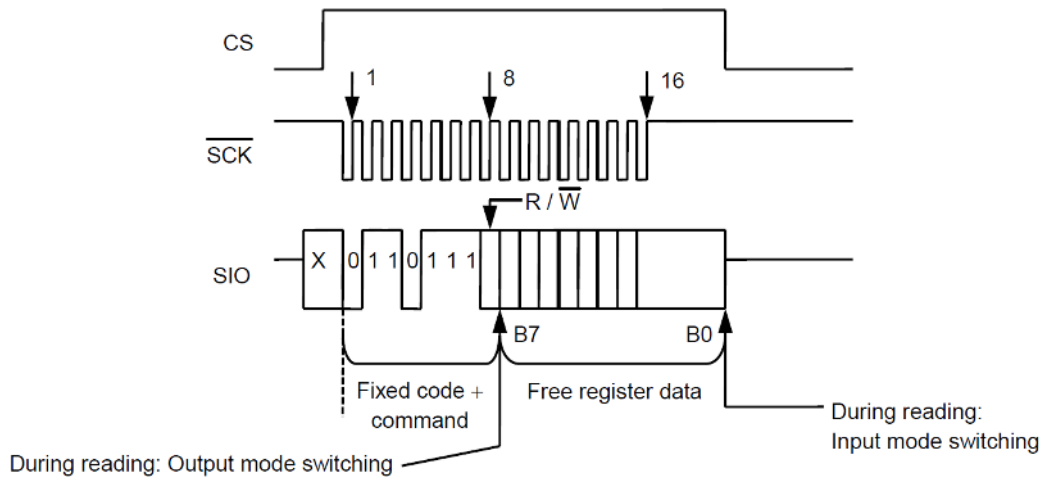

**Free Register Access**

**12. Flowchart of Initialization and Example of Real-time Data Set-up**

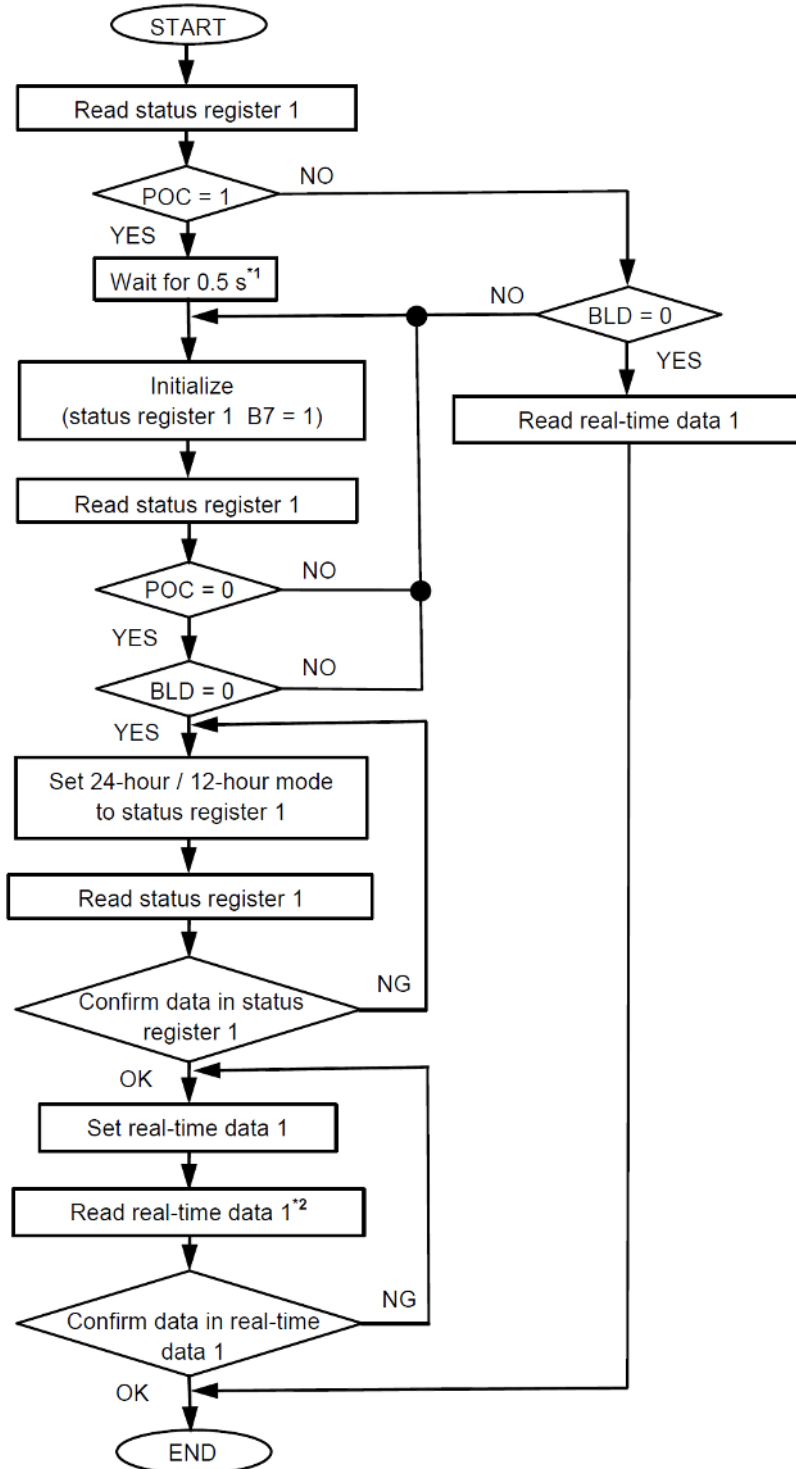

\*1. Do not communicate for 0.5 seconds since the power-on detection circuit is in operation.

\*2. Reading the real-time data 1 should be completed within 1 second after setting the real-time data 1.

**Example of Initialization Flowchart**

### 13. Examples of Application Circuits

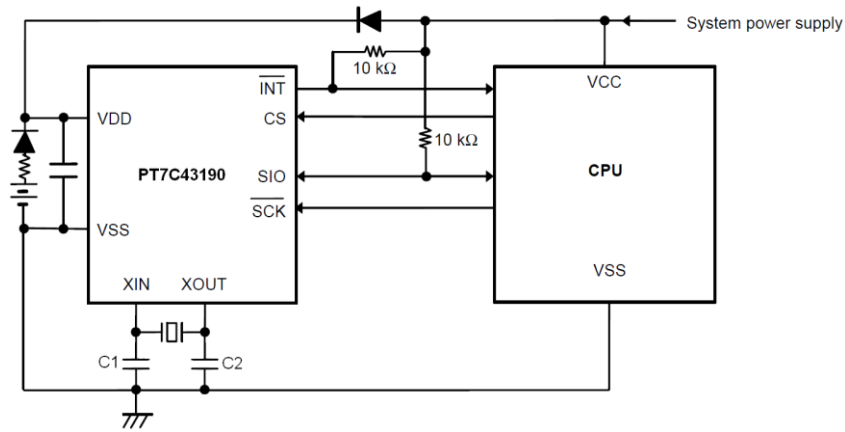

Caution: Start communication under stable condition after power-on the power supply in the system.

Caution: The above connection diagrams do not guarantee operation. Set the constants after performing sufficient evaluation using the actual application.

#### Examples of Application Circuits for PT7C43190

### Part Marking

Top mark not available at this time. To obtain advance information regarding the top mark, please contact your local sales representative.

**Packaging Mechanical:  
8-WDFN (ZE)**

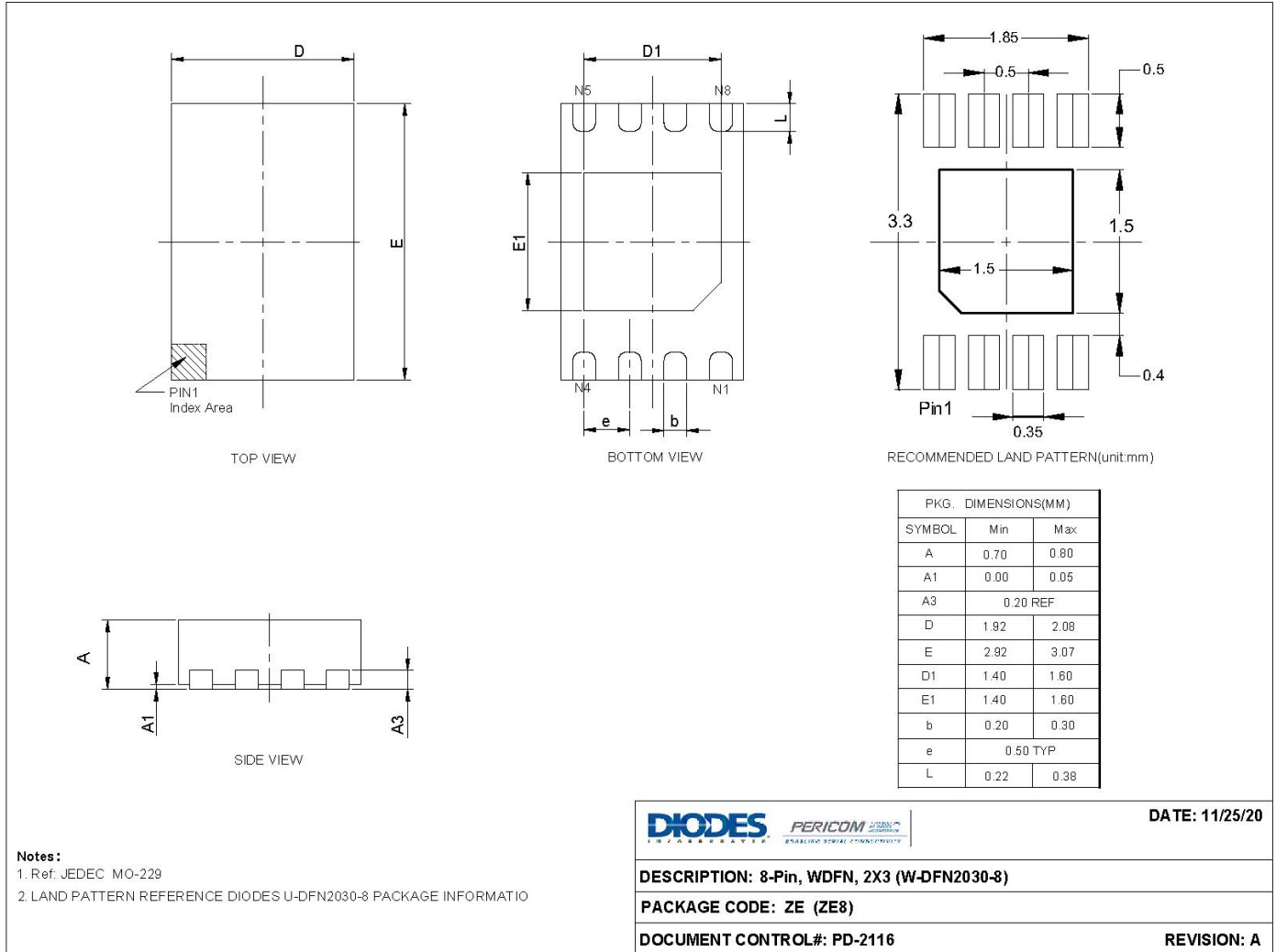

For latest package info,  
please check: <http://www.diodes.com/design/support/packaging/pericom-packaging/packaging-mechanicals-and-thermal-characteristics/>

**Ordering Information**

Part Number	Package Code	Package Description
PT7C43190ZEEX	ZE	8-pin, 2x3 (WDFN) (W-DFN2030-8)

- Notes:**
- No purposely added lead. Fully EU Directive 2002/95/EC (RoHS), 2011/65/EU (RoHS 2) & 2015/863/EU (RoHS 3) compliant.
  - See <https://www.diodes.com/quality/lead-free/> for more information about Diodes Incorporated's definitions of Halogen- and Antimony-free, "Green" and Lead-free.
  - Halogen- and Antimony-free "Green" products are defined as those which contain <900ppm bromine, <900ppm chlorine (<1500ppm total Br + Cl) and <1000ppm antimony compounds.
  - E = Pb-free and Green
  - X suffix = Tape/Reel



**IMPORTANT NOTICE**

1. DIODES INCORPORATED AND ITS SUBSIDIARIES (“DIODES”) MAKE NO WARRANTY OF ANY KIND, EXPRESS OR IMPLIED, WITH REGARDS TO ANY INFORMATION CONTAINED IN THIS DOCUMENT, INCLUDING, BUT NOT LIMITED TO, THE IMPLIED WARRANTIES OF MERCHANTABILITY, FITNESS FOR A PARTICULAR PURPOSE OR NON-INFRINGEMENT OF THIRD PARTY INTELLECTUAL PROPERTY RIGHTS (AND THEIR EQUIVALENTS UNDER THE LAWS OF ANY JURISDICTION).
2. The Information contained herein is for informational purpose only and is provided only to illustrate the operation of Diodes products described herein and application examples. Diodes does not assume any liability arising out of the application or use of this document or any product described herein. This document is intended for skilled and technically trained engineering customers and users who design with Diodes products. Diodes products may be used to facilitate safety-related applications; however, in all instances customers and users are responsible for (a) selecting the appropriate Diodes products for their applications, (b) evaluating the suitability of the Diodes products for their intended applications, (c) ensuring their applications, which incorporate Diodes products, comply the applicable legal and regulatory requirements as well as safety and functional-safety related standards, and (d) ensuring they design with appropriate safeguards (including testing, validation, quality control techniques, redundancy, malfunction prevention, and appropriate treatment for aging degradation) to minimize the risks associated with their applications.
3. Diodes assumes no liability for any application-related information, support, assistance or feedback that may be provided by Diodes from time to time. Any customer or user of this document or products described herein will assume all risks and liabilities associated with such use, and will hold Diodes and all companies whose products are represented herein or on Diodes’ websites, harmless against all damages and liabilities.
4. Products described herein may be covered by one or more United States, international or foreign patents and pending patent applications. Product names and markings noted herein may also be covered by one or more United States, international or foreign trademarks and trademark applications. Diodes does not convey any license under any of its intellectual property rights or the rights of any third parties (including third parties whose products and services may be described in this document or on Diodes’ website) under this document.
5. Diodes products are provided subject to Diodes’ Standard Terms and Conditions of Sale (<https://www.diodes.com/about/company/terms-and-conditions/terms-and-conditions-of-sales/>) or other applicable terms. This document does not alter or expand the applicable warranties provided by Diodes. Diodes does not warrant or accept any liability whatsoever in respect of any products purchased through unauthorized sales channel.
6. Diodes products and technology may not be used for or incorporated into any products or systems whose manufacture, use or sale is prohibited under any applicable laws and regulations. Should customers or users use Diodes products in contravention of any applicable laws or regulations, or for any unintended or unauthorized application, customers and users will (a) be solely responsible for any damages, losses or penalties arising in connection therewith or as a result thereof, and (b) indemnify and hold Diodes and its representatives and agents harmless against any and all claims, damages, expenses, and attorney fees arising out of, directly or indirectly, any claim relating to any noncompliance with the applicable laws and regulations, as well as any unintended or unauthorized application.
7. While efforts have been made to ensure the information contained in this document is accurate, complete and current, it may contain technical inaccuracies, omissions and typographical errors. Diodes does not warrant that information contained in this document is error-free and Diodes is under no obligation to update or otherwise correct this information. Notwithstanding the foregoing, Diodes reserves the right to make modifications, enhancements, improvements, corrections or other changes without further notice to this document and any product described herein. This document is written in English but may be translated into multiple languages for reference. Only the English version of this document is the final and determinative format released by Diodes.
8. Any unauthorized copying, modification, distribution, transmission, display or other use of this document (or any portion hereof) is prohibited. Diodes assumes no responsibility for any losses incurred by the customers or users or any third parties arising from any such unauthorized use.

Copyright © 2021 Diodes Incorporated

[www.diodes.com](http://www.diodes.com)