

PART NO.

RFN-1002C-H1

REV	DESCRIPTION	DWN	DATE	APPROVED
B	UPDATED TRIM TOOL P/N	CZS	07/19/19	JDMc

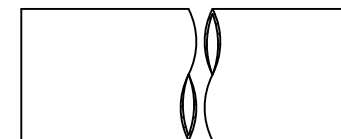
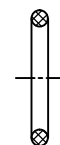
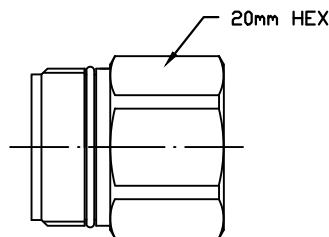
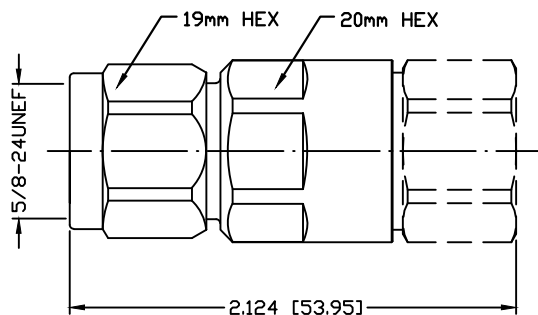

(NTS)

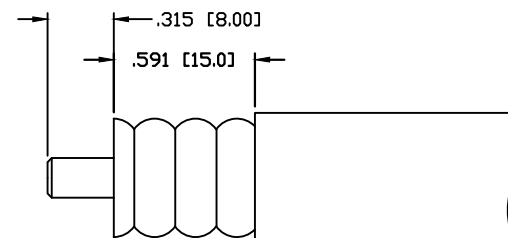
RECOMMENDED STRIPING DIMENSIONSUSE OF CABLE TRIM TOOL IS RECOMMENDEDUSE COMPATIBLE TRIM TOOL SUCH AS TRIM-SET-C02SPECIFICATIONS:

IMPEDANCE: 50 Ohms

FREQUENCY RANGE: DC-3GHz GHZ

VSWR AVERAGE: <1:1.15

PIM: <-155 dBc

TEMPERATURE RANGE: -55°C TO 165°C

FOR LCF12-50JFN, LDF4-50A, ICA12-50JPL, PD353784 & SPF CABLE

12	TUBING	1	HEAT SHRINK	---
11	CLAMP	1	BRASS	WHITE BRONZE
10	O-RING	1	RUBBER	---
9	RETAINING RING	1	BRASS	WHITE BRONZE
8	SHELL	1	BRASS	WHITE BRONZE
7	BACK NUT	1	BRASS	WHITE BRONZE
6	COLLET RING	1	Be,Cu.	WHITE BRONZE
5	GASKET	1	RUBBER	---
4	INSULATOR	1	PTFE	---
3	PIN	1	BRASS	SILVER
2	INSULATOR	1	PTFE	---
1	BODY	1	BRASS	WHITE BRONZE
#	DESCRIPTION	QTY	MATERIAL	FINISH

CUSTOMER
OUTLINE DRAWINGALL DIMENSIONS
ARE REFERENCE ONLYUNLESS OTHERWISE SPECIFIED:
DIMENSIONS ARE IN INCHES
AND [MILLIMETERS]DRAWN
C. ZUNIGA 07/19/19
CHECKEDORJ DRAWN
C. ZUNIGA 11/17/15**RoHS
COMPLIANT**PROPRIETARY AND CONFIDENTIAL
THIS DRAWING CONTAINS
INFORMATION PROPRIETARY TO
RF INDUSTRIES. ANY
UNAUTHORIZED USE OF THIS
DRAWING IS EXPRESSLY
PROHIBITED WITHOUT WRITTEN
PERMISSION FROM RF
INDUSTRIES. ANY VIOLATION IS
PUNISHABLE UNDER U.S.
COPYRIGHT LAWS.

RFconnectors
DIVISION OF RF INDUSTRIES, LTD. (858) 549-6345 FAX

7610 MIRAMAR RD.
SAN DIEGO, CA 92126
(858) 549-6340

N MALE CAPTIVATED CLAMP
FOR 1/2" FLEXIBLE CORRUGATED CABLE

SIZE	CABLE GROUP	DWG NO.	REVISION
A	H1	RFN-1002C-H1	B
SCALE:	ENGINEERING ID:	SHEET 1 OF 1	
NTS	001787		