

CCB LC450029PKB



ON Semiconductor®

<http://onsemi.com>

CMOS IC

1/4 and 1/3-Duty General-Purpose LCD Display Driver

Overview

The LC450029PKB is 1/4 duty and 1/3 duty general-purpose microcontroller-controlled LCD drivers that can be used in applications such as frequency display in products with electronic tuning. In addition to being capable to drive up to 208 segments directly. The internal oscillation circuit helps to reduce the number of external resistors and capacitors required. The chip shape is slim for COG (Chip-On-Glass) implementation. The operating temperature range is from -40°C to +105°C

Application

- Car or general consumer electronic LCD display equipment.

Features

- Selectable 1/4-duty or 1/3-duty drive by the serial control data
 - When 1/4-duty: Capable of driving up to 208 segments
 - When 1/3-duty: Capable of driving up to 159 segments
- 1/3-bias only
- Serial data input supports CCB* format communication with the system controller. (For 5V operation only)
- The power-saving mode is selectable by the serial control data, and supports low power consumption.
- Adjustable the frame frequency of the common and segment output waveforms by the serial control data
- Selectable the internal oscillator operating or external clock operating mode by the serial control data
- High generality, since display data is displayed directly without the intervention of a decoder circuit.
- The INH pad allows all LCD segments to be forced to the off state.
- With a built-in oscillator circuit (External resistors and capacitors are unnecessary.)
- The stability of the LCD bias voltage is high by a built-in LCD bias generator with voltage-follower buffers.
- Shipping form: Chip with Au bumps in tray.
- Allowable operating voltage (VDD, VDDI) : +4.5V to +6.0V
- Allowable wide operating temperature ranges : -40°C to +105°C

- CCB is ON Semiconductor®'s original format. All addresses are managed by ON Semiconductor® for this format.

- CCB is a registered trademark of Semiconductor Components Industries, LLC.

LC450029PKB

Specifications

Absolute Maximum Ratings at $T_a = 25^\circ\text{C}$, $V_{SS} = 0\text{V}$

Parameter	Symbol	Conditions	Ratings	Unit
Maximum supply voltage	$V_{DD\text{ max}}$, $V_{DDI\text{ max}}$	$V_{DD}=V_{DDI}$	-0.3 to +6.5	V
Input voltage	V_{IN1}	CE, CL, DI, $\overline{\text{INH}}$	-0.3 to +6.5	V
	V_{IN2}	OSCI	-0.3 to $V_{DDI}+0.3$	
Output voltage	V_{OUT}	S1 to S53, COM1 to COM4	-0.3 to $V_{DD}+0.3$	V
Output current	I_{OUT1}	S1 to S53	300	μA
	I_{OUT2}	COM1 to COM4	3	mA
Operating temperature	T_{opr}		-40 to +105	$^\circ\text{C}$
Storage temperature	T_{stg}		-55 to +125	$^\circ\text{C}$

(Note) Power supply pads (V_{DD} , V_{DDI}) should connect all pads to the same power supply.

(See sample applications circuits)

Stresses exceeding Maximum Ratings may damage the device. Maximum Ratings are stress ratings only. Functional operation above the Recommended Operating Conditions is not implied. Extended exposure to stresses above the Recommended Operating Conditions may affect device reliability.

Allowable Operating Ranges at $T_a = -40$ to $+105^\circ\text{C}$, $V_{SS} = 0\text{V}$

Parameter	Symbol	Conditions	Ratings			Unit
			min	typ	max	
Supply voltage	V_{DD} , V_{DDI}	$V_{DD}=V_{DDI}$	4.5		6.0	V
Input high-level voltage	V_{IH1}	CE, CL, DI, $\overline{\text{INH}}$	$0.8V_{DD}$		6.0	V
	V_{IH2}	OSCI: External clock operating mode	$0.8V_{DD}$		V_{DDI}	
Input low-level voltage	V_{IL1}	CE, CL, DI, $\overline{\text{INH}}$	0		$0.2V_{DDI}$	V
	V_{IL2}	OSCI: External clock operating mode	0		$0.2V_{DDI}$	
External clock operating frequency	f_{CK}	OSCI: External clock operating mode [Figure 4]	10	300	600	kHz
External clock duty cycle	D_{CK}	OSCI: External clock operating mode [Figure 4]	30	50	70	%
Data setup time	tds	CL, DI [Figure 2][Figure 3]	160			ns
Data hold time	tdh	CL, DI [Figure 2][Figure 3]	160			ns
CE wait time	tcp	CE, CL [Figure 2][Figure 3]	160			ns
CE setup time	tcs	CE, CL [Figure 2][Figure 3]	160			ns
CE hold time	tch	CE, CL [Figure 2][Figure 3]	160			ns
High-level clock pulse width	$t_{\phi H}$	CL [Figure 2][Figure 3]	160			ns
Low-level clock pulse width	$t_{\phi L}$	CL [Figure 2][Figure 3]	160			ns
Rise time	t_r	CE, CL, DI [Figure 2][Figure 3]		160		ns
Fall time	t_f	CE, CL, DI [Figure 2][Figure 3]		160		ns
$\overline{\text{INH}}$ switching time	tc	$\overline{\text{INH}}$, CE [Figure 5][Figure 6]	10			μs

(Note) Power supply pads (V_{DD} , V_{DDI}) should connect all pads to the same power supply.

(See sample applications circuits)

LC450029PKB

Electrical Characteristics for the Allowable Operating Ranges

Parameter	Symbol	Pin	Conditions	Ratings			Unit
				min	typ	max	
Hysteresis	V_{H1}	CE, CL, DI, \overline{INH}			$0.1V_{DDI}$		V
	V_{H2}	OSCI	External clock operating mode		$0.1V_{DDI}$		
Input high-level current	I_{IH1}	CE, CL, DI, \overline{INH}	$V_I = 6.0V$			5.0	μA
	I_{IH2}	OSCI	$V_I = V_{DDI}$, External clock operating mode			5.0	
Input low-level current	I_{IL1}	CE, CL, DI, \overline{INH}	$V_I = 0V$	-5.0			μA
	I_{IL2}	OSCI	$V_I = 0V$, External clock operating mode	-5.0			
Output high-level voltage	V_{OH1}	S1 to S53	$I_O = -20\mu A$	$V_{DD}-0.9$			V
	V_{OH2}	COM1 to COM4	$I_O = -100\mu A$	$V_{DD}-0.9$			
Output low-level voltage	V_{OL1}	S1 to S53	$I_O = 20\mu A$			0.9	V
	V_{OL2}	COM1 to COM4	$I_O = 100\mu A$			0.9	
Output middle-level voltage *1	V_{MID1}	S1 to S53	$I_O = \pm 20\mu A$	$2/3V_{DD}-0.9$		$2/3V_{DD}+0.9$	V
	V_{MID2}	S1 to S53	$I_O = \pm 20\mu A$	$1/3V_{DD}-0.9$		$1/3V_{DD}+0.9$	
	V_{MID3}	COM1 to COM4	$I_O = \pm 100\mu A$	$2/3V_{DD}-0.9$		$2/3V_{DD}+0.9$	
	V_{MID4}	COM1 to COM4	$I_O = \pm 100\mu A$	$1/3V_{DD}-0.9$		$1/3V_{DD}+0.9$	
Oscillator frequency	fosc	Internal oscillator circuit	Internal oscillator operating mode	210	300	390	kHz
Current drain (Total value of V_{DD} and V_{DDI})	I_{DD1}	V_{DD}, V_{DDI}	< Power-saving mode > $V_{DD}=V_{DDI}=6.0V$		40	100	μA
	I_{DD2}	V_{DD}, V_{DDI}	< Internal oscillator operating mode > $V_{DD}=V_{DDI}=6.0V$ Driver outputs are open.		200	400	
	I_{DD3}	V_{DD}, V_{DDI}	< External clock operating mode > $V_{DD}=V_{DDI}=6.0V$ $f_{CK}=300kHz$ Driver outputs are open.		170	340	

*1: Excluding the amount of voltage drop of the LCD BIAS GENERATOR which generates V_{DD1} and V_{DD2} .
(See Figure 1.)

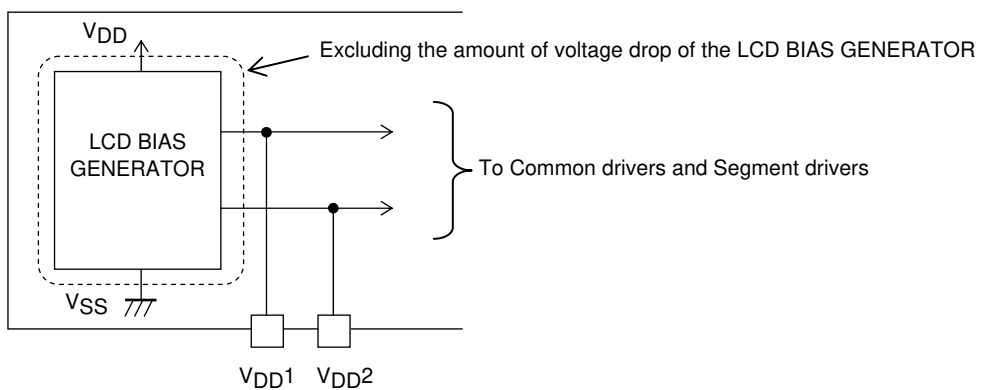

[Figure 1]

LC450029PKB

(1) When CL is stopped at the low level

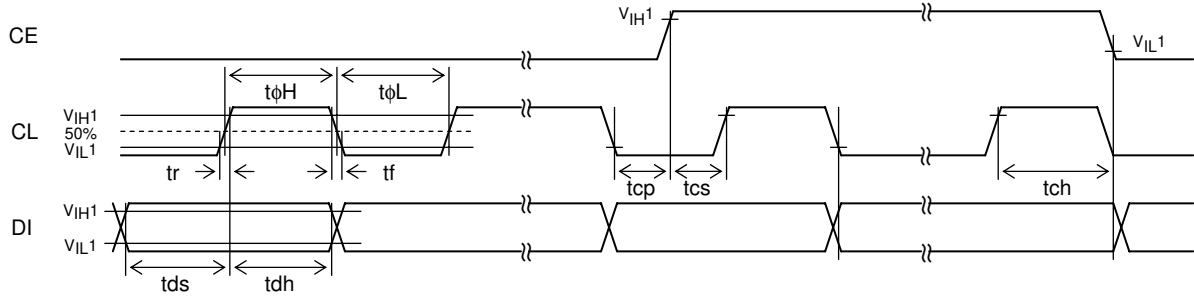

[Figure 2]

(2) When CL is stopped at the high level

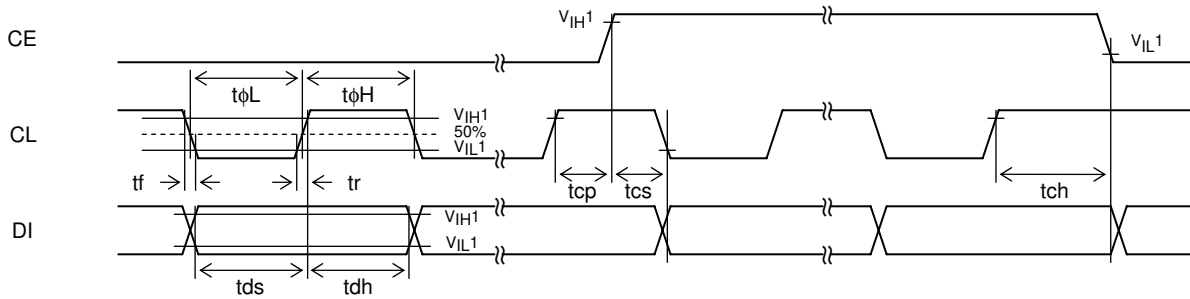

[Figure 3]

(3) OSCI pad clock timing in external clock operating mode

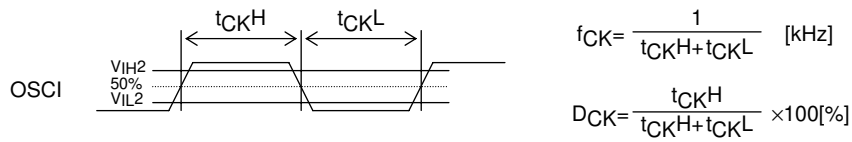

[Figure 4]

$$f_{CK} = \frac{1}{t_{CKH} + t_{CKL}} \text{ [kHz]}$$

$$D_{CK} = \frac{t_{CKH}}{t_{CKH} + t_{CKL}} \times 100\%$$

LC450029PKB

Block Diagram

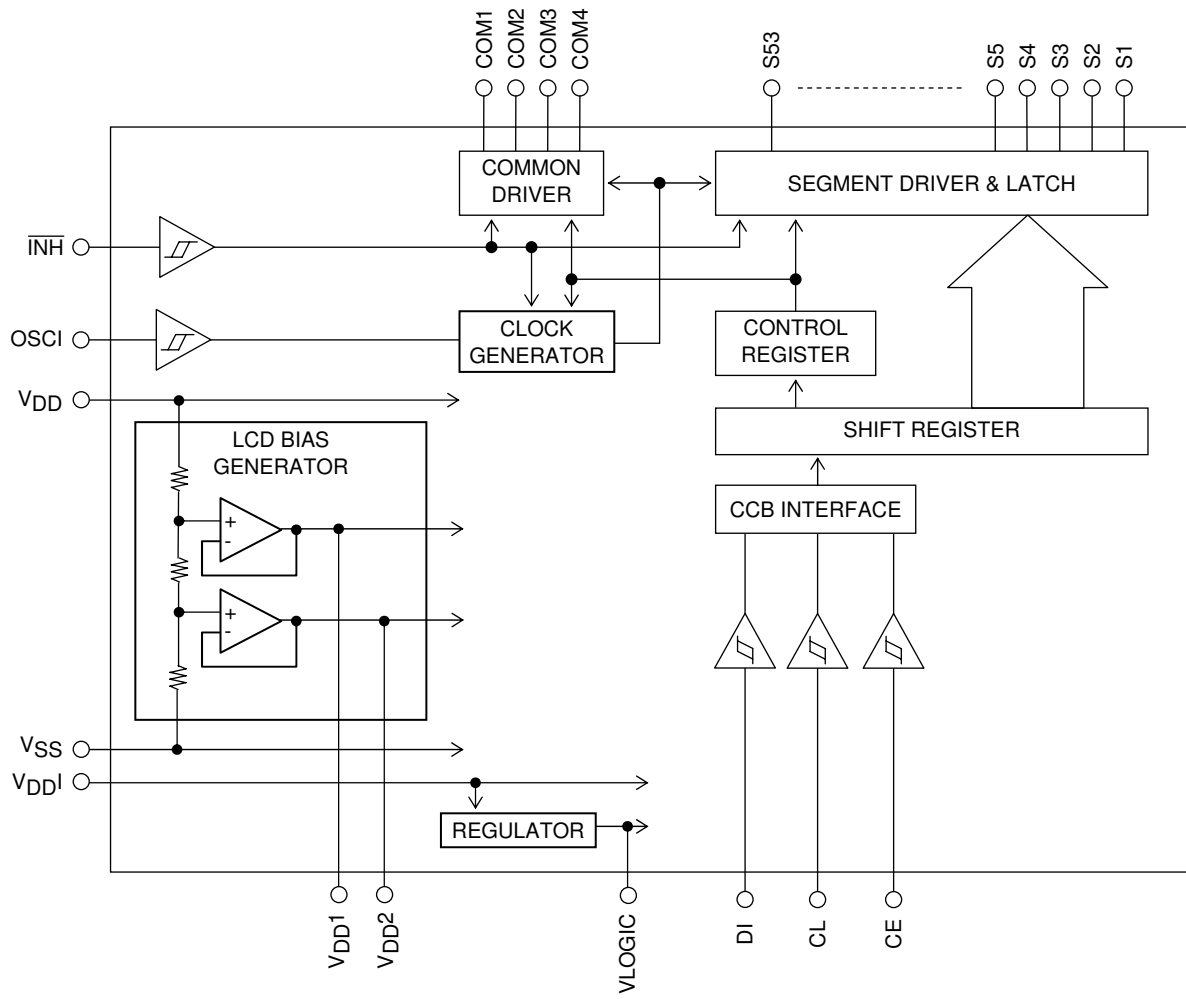

LC450029PKB

Pad Functions

Symbol	Pad No.	Function	Active	I/O	Handling when unused
COM1 to COM4	2 to 5	Common driver outputs. The frame frequency is fo[Hz]. COM4 pad outputs the V _{SS} level in 1/3-duty.	-	O	OPEN
S1 to S53	6 to 58	Segment outputs for displaying the display data transferred by serial data input. S51 pad outputs the V _{SS} level in 1/4-duty. S52 pad and S53 pad output the V _{SS} level at the control data DN="0". S53 pad outputs the V _{SS} level at external clock operating mode.	-	O	OPEN
$\overline{\text{INH}}$	61	Display off control input <ul style="list-style-type: none"> • $\overline{\text{INH}}$ = low (V_{SS}) ...Display forced off (V_{SS} level Output) S1 to S53 = low (V_{SS}) COM1 to COM4 = low (V_{SS}) The internal oscillator stops. Stops inputting external clock. Serial data transfer can be used. • $\overline{\text{INH}}$ = high (V_{DD})...Display on Enables the internal oscillator circuit. (Internal oscillator operating mode) Enables external clock input. (External clock operating mode) While display on, LCD outputs force off (V _{SS} level output) by the control data BU="1". While display on, LCD outputs off (off waveforms output) by the control data SC="1".	L	I	GND (V _{SS})
CE DI CL	62 63 64	Serial data transfer inputs. Must be connected to the controller. CE: Chip enable DI: Transfer data CL: Synchronization clock	H - 	I I I	GND (V _{SS})
VLOGIC	65	Used to monitor pad for the power supply voltage of the logic circuit.	-	O	OPEN
V _{DD} I	66 to 71	Power supply pad. A power voltage of 4.5 to 6.0V must be applied to these pads.	-	-	-
OSCI	72	This pad can also be used as the external clock input pad when the external clock operating mode is selected by control data. This pad must be connected to GND at internal oscillator operating mode.	-	I	GND (V _{SS})
V _{SS}	73 to 90	Ground pad. Must be connected to ground.	-	-	-
V _{DD} 2	91	Used to monitor pad for the LCD drive bias voltage (1/3 V _{DD}).	-	O	OPEN
V _{DD} 1	92	Used to monitor pad for the LCD drive bias voltage (2/3 V _{DD}).	-	O	OPEN
V _{DD}	93 to 105	Power supply pad. A power voltage of 4.5 to 6.0V must be applied to these pads.	-	-	-
DUMMY	1, 59, 60, 106	Dummy pad. Must not be used.	-	OPEN	OPEN

(Note)

- Power supply pads (V_{DD}, V_{DD}I) should connect all pads to the same power supply.
(See sample applications circuits)
- GND pad (V_{SS}) should connect all pads to the GND.
- When logic input pads ($\overline{\text{INH}}$, CE, DI, CL, OSCI) are not used, must be fixed to GND (V_{SS}).
- Must not use monitor pads (VLOGIC, V_{DD}1, V_{DD}2) in an external circuit.
- Must not connect dummy pad (DUMMY) mutually. Moreover, never use it in an external circuit.

Serial Data Input

1. 1/4 duty

(1) When CL is stopped at the low level

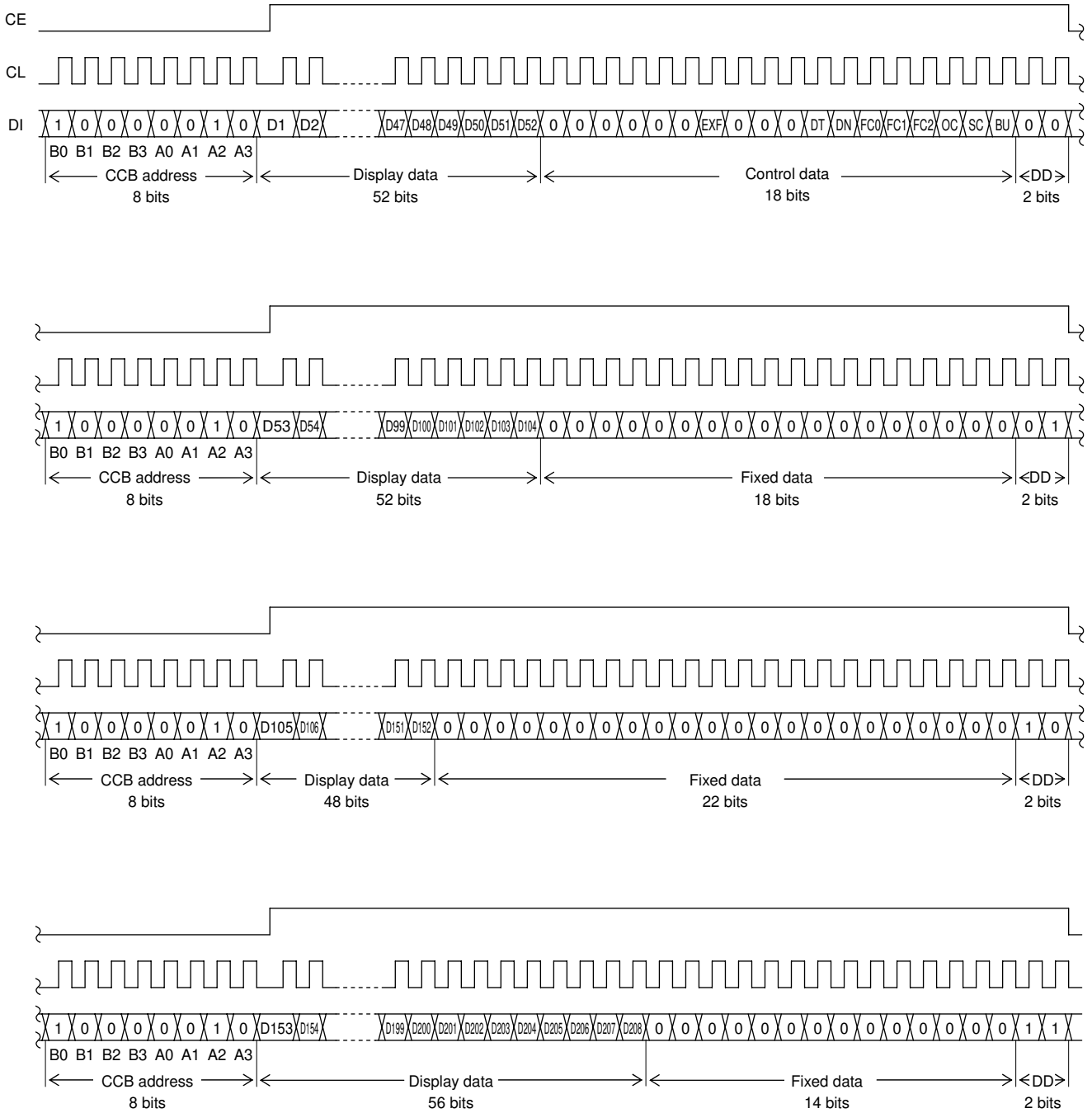

Note: DD is the direction data.

LC450029PKB

(2) When CL is stopped at the high level

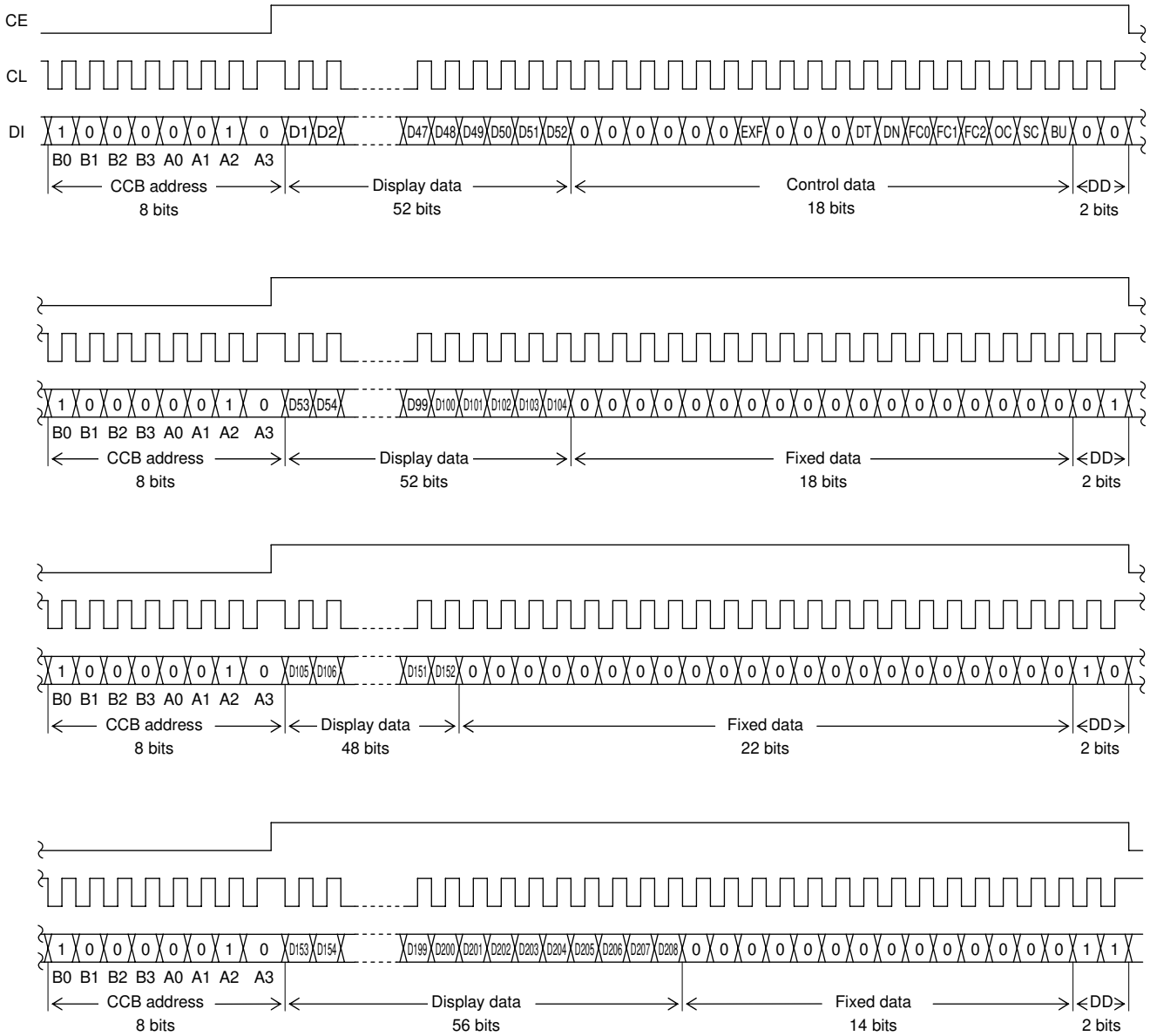

Note: DD is the direction data.

- CCB address “41H”
- D1 to D208 Display data
- EXF Ratio of dividing frequency in external clock operating mode setting control data
- DT 1/4-duty drive or 1/3-duty drive switching control data
- DN The number of the maximum display segments setting control data
- FC0 to FC2 Common/segment output waveform frame frequency control data
- OC Internal oscillator operating mode/external clock operating mode switching control data
- SC Segment on/off (off waveform output) control data
- BU Normal mode/power-saving mode control data

LC450029PKB

2. 1/3 duty

(1) When CL is stopped at the low level

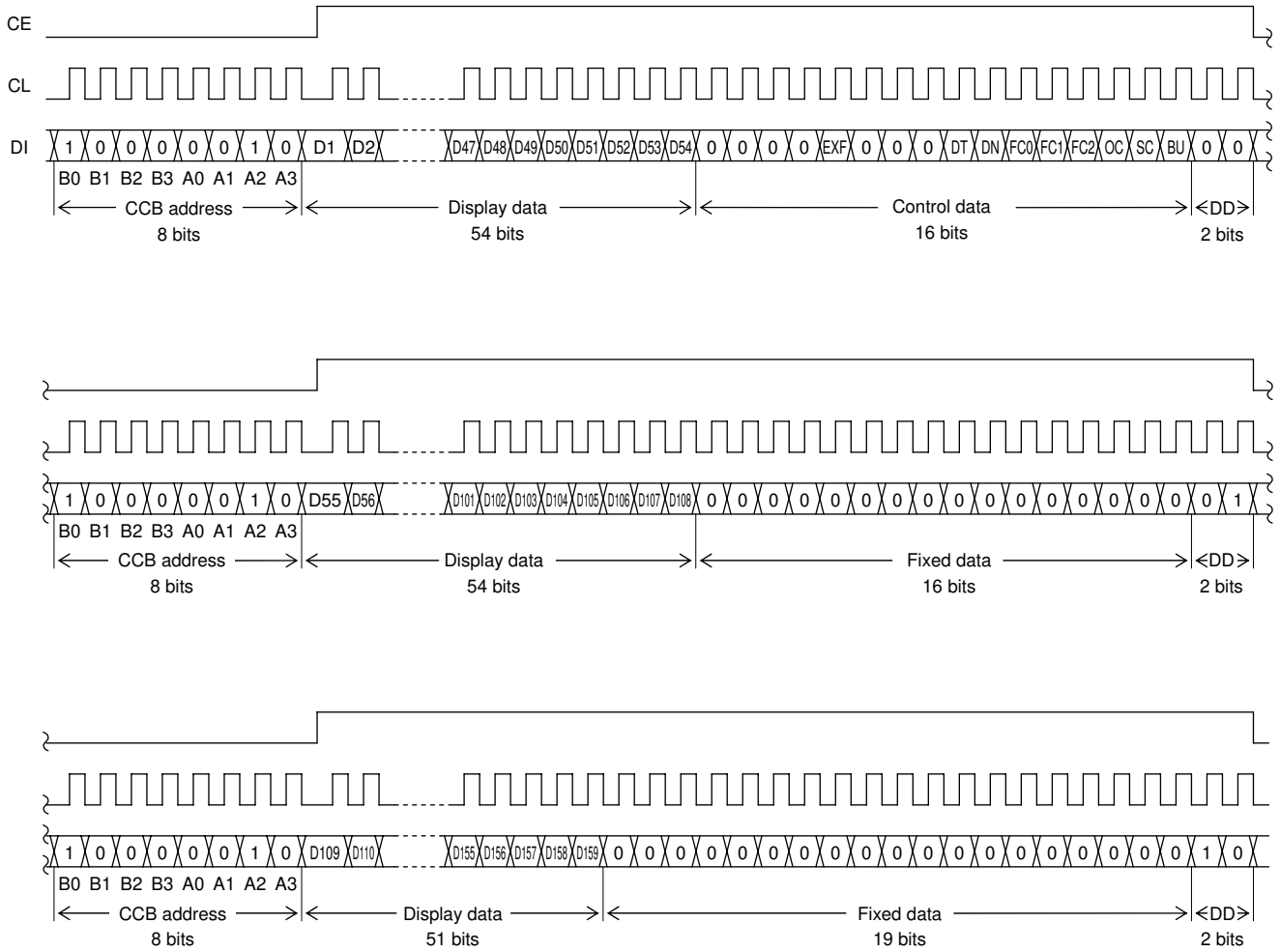

Note: DD is the direction data.

LC450029PKB

(2) When CL is stopped at the high level

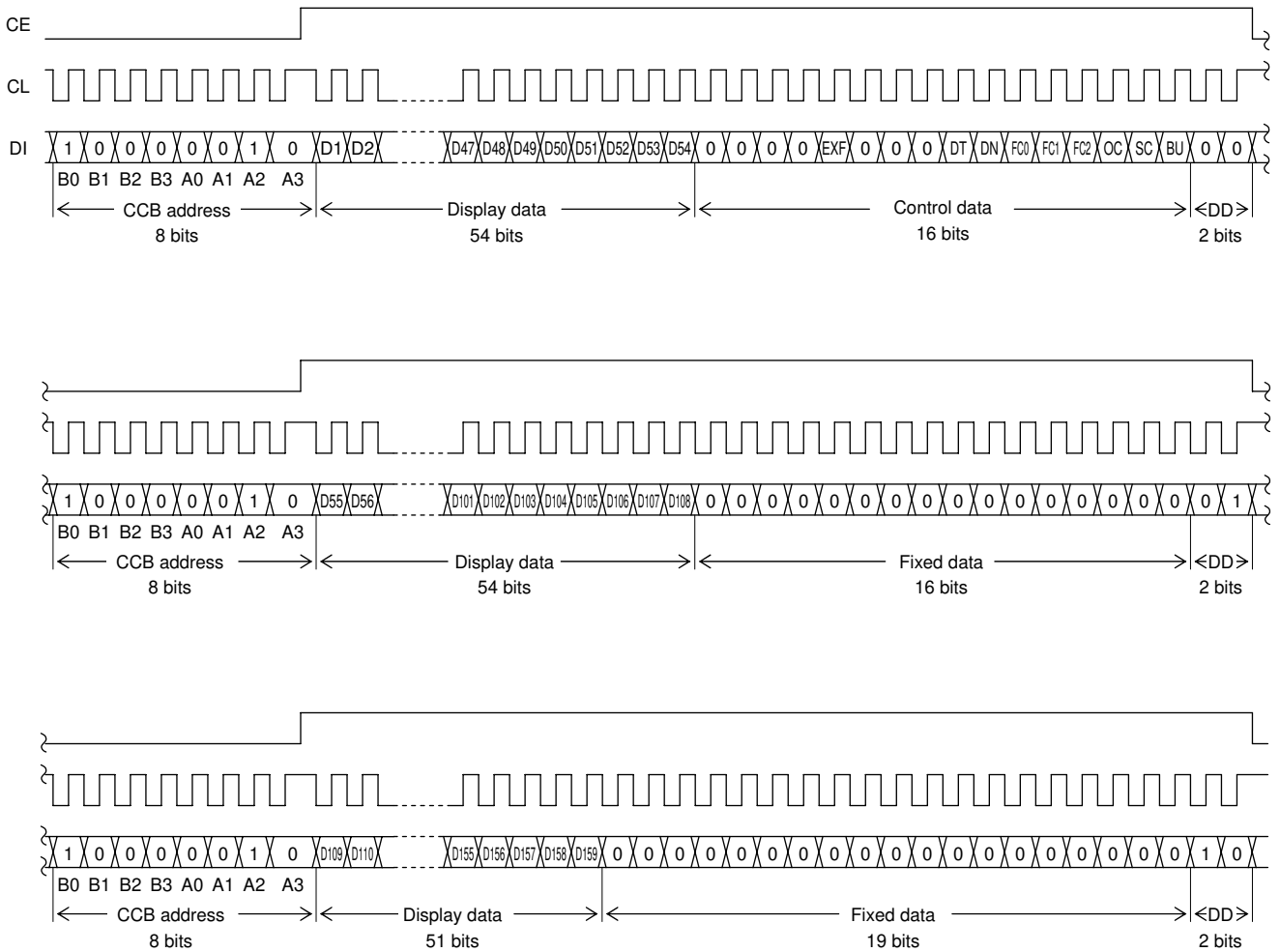

Note: DD is the direction data.

- CCB address “41H”
- D1 to D208 Display data
- EXF Ratio of dividing frequency in external clock operating mode setting control data
- DT 1/4-duty drive or 1/3-duty drive switching control data
- DN The number of the maximum display segments setting control data
- FC0 to FC2 Common/segment output waveform frame frequency control data
- OC Internal oscillator operating mode/external clock operating mode switching control data
- SC Segment on/off (off waveform output) control data
- BU Normal mode/power-saving mode control data

Serial Data Transfer Example

1. 1/4 duty

- When 153 or more segments are used
All 320 bits (include CCB address) of serial data must be sent.

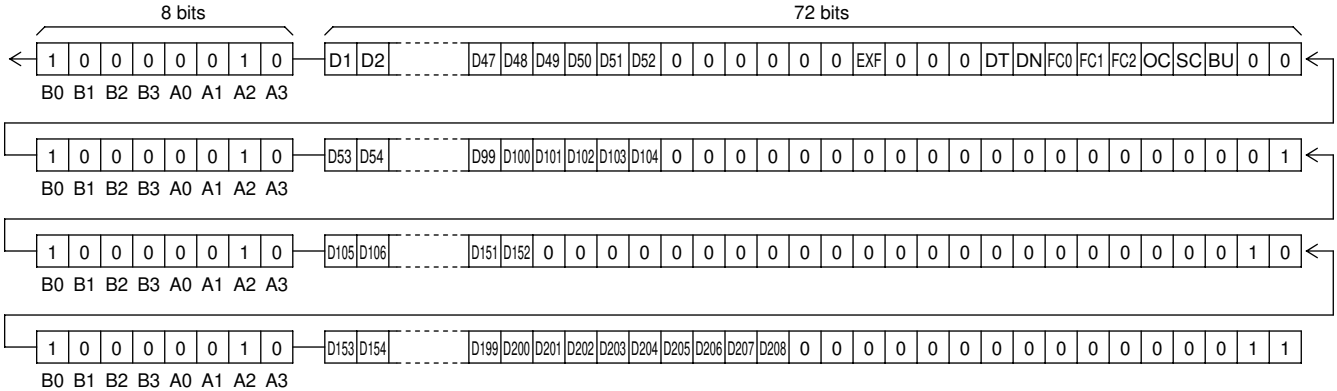

- When fewer than 153 segments are used
One of 80, 160 and 240 bits of serial data must be sent, depending on the number of segments to be used. However, the serial data shown below (the D1 to D52 display data, the control data and DD="00") must always be sent.

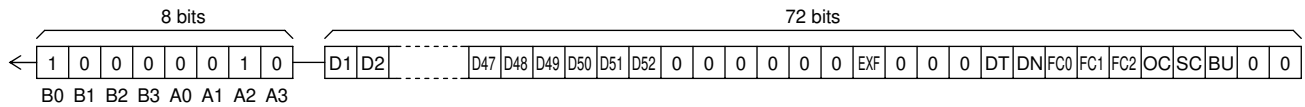

2. 1/3 duty

- When 109 or more segments are used
All 240 bits (include CCB address) of serial data must be sent.

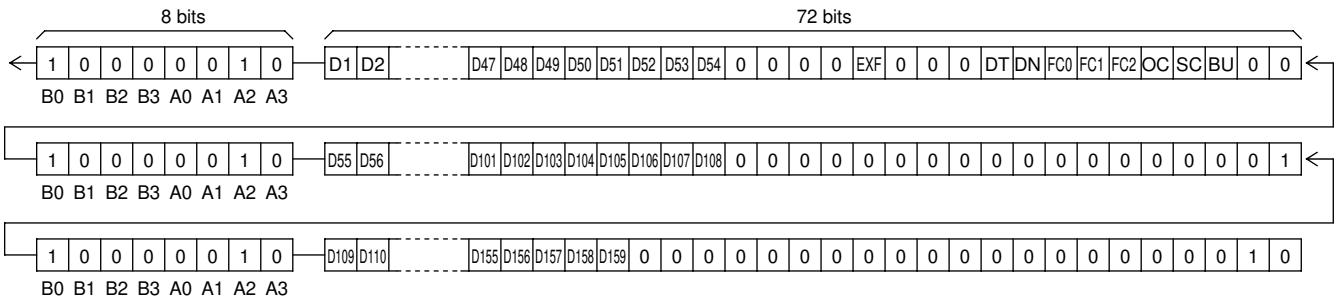

- When fewer than 109 segments are used
Either 80 or 160 bits of serial data must be sent, depending on the number of segments to be used. However, the serial data shown below (the D1 to D54 display data, the control data and DD="00") must always be sent.

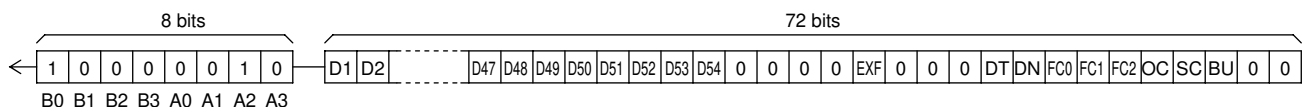

Control Data Functions

(1) EXF ... Ratio of dividing frequency in external clock operating mode setting control data

This control data sets the ratio of dividing frequency of the external clock which input into the OSC1 pad, when the external clock operating mode (OC="1") is set. However, this data is effective only when external clock operating mode (OC= "1") is set. The frame frequency is adjustable by setting EXF, FC0 to FC2 and OC.

EXF	Ratio of dividing frequency in external clock operating mode
0	$f_{CK} / 8$
1	f_{CK}

(2) DT ...1/4-duty drive or 1/3-duty drive switching control data

This control data bit selects either 1/4-duty drive or 1/3-duty drive.

DT	Drive scheme	S51 pad's state
0	1/4-duty drive	Low (V_{SS}) level output
1	1/3-duty drive	S51 (segment output)

(3) DN ...The number of the maximum display segments setting control data

This control data bit sets the number of the maximum display segments.

DN	The number of the maximum display segments		Pad's state	
	1/4 duty	1/3 duty	S52	S53
0	Up to 200 segments	Up to 153 segments	"L" (V_{SS})	"L" (V_{SS})
1	Up to 208 segments	Up to 159 segments	S52 (segment output)	S53 (segment output)

(Note) S53 pad outputs V_{SS} level in external clock operating mode.

(4) FC0 to FC2 ... Common/segment output waveform frame frequency control data

These control data bits set the frame frequency of the common and segment output waveforms. The frame frequency is adjustable by setting EXF, FC0 to FC2 and OC.

Control data			Frame frequency fo[Hz]		
FC0	FC1	FC2	Internal oscillator operating mode	External clock operating mode	External clock operating mode
			(The control data OC="0", fosc=300[kHz]typ)	(The control data OC="1", EXF="0") Case is $f_{CK}=300$ [kHz].	(The control data OC="1", EXF="1") Case is $f_{CK}=38$ [kHz].
0	0	0	$f_{osc}/6144 = 48.8$ [Hz]typ	$f_{CK}/6144 = 48.8$ [Hz]	$f_{CK}/768 = 49.5$ [Hz]
0	0	1	$f_{osc}/4608 = 65.1$ [Hz]typ	$f_{CK}/4608 = 65.1$ [Hz]	$f_{CK}/576 = 66.0$ [Hz]
0	1	0	$f_{osc}/3072 = 97.7$ [Hz]typ	$f_{CK}/3072 = 97.7$ [Hz]	$f_{CK}/384 = 99.0$ [Hz]
0	1	1	$f_{osc}/2304 = 130.2$ [Hz]typ	$f_{CK}/2304 = 130.2$ [Hz]	$f_{CK}/288 = 131.9$ [Hz]
1	0	0	$f_{osc}/1536 = 195.3$ [Hz]typ	$f_{CK}/1536 = 195.3$ [Hz]	$f_{CK}/192 = 197.9$ [Hz]
1	0	1	$f_{osc}/1152 = 260.4$ [Hz]typ	$f_{CK}/1152 = 260.4$ [Hz]	$f_{CK}/144 = 263.9$ [Hz]
1	1	0	$f_{osc}/768 = 390.6$ [Hz]typ	$f_{CK}/768 = 390.6$ [Hz]	$f_{CK}/96 = 395.8$ [Hz]
1	1	1	$f_{osc}/3072 = 97.7$ [Hz]typ	$f_{CK}/3072 = 97.7$ [Hz]	$f_{CK}/384 = 99.0$ [Hz]

(5) OC ...Internal oscillator operating mode/external clock operating mode switching control data

This control data bit selects either the internal oscillator operating mode or external clock operating mode.

OC	Fundamental clock operating mode	S53 pad's state
0	Internal oscillator operating mode	S53 (segment output)
1	External clock operating mode	Low (V_{SS}) level output

(6) SC ... Segment on/off (off waveform output) control data

This control data bit controls the on/off (off waveform output) state of all the segments.

SC	Display state
0	On
1	Off of all the segments (off waveform output)

(7) BU ... Normal mode/power-saving mode control data

This control data bit selects either normal mode or power-saving mode.

BU	Mode
0	Normal mode
1	Power-saving mode All of the common and segment output pads output the V_{SS} level. In this mode, the internal oscillator circuit stops oscillation if the IC is in the internal oscillator operating mode (OC=0), and the IC stops receiving external clock signals if the IC is in the external clock operating mode (OC=1).

LC450029PKB

Display Data and Output Pad Correspondence (1/4 Duty)

Output pad	COM1	COM2	COM3	COM4
S1	D1	D2	D3	D4
S2	D5	D6	D7	D8
S3	D9	D10	D11	D12
S4	D13	D14	D15	D16
S5	D17	D18	D19	D20
S6	D21	D22	D23	D24
S7	D25	D26	D27	D28
S8	D29	D30	D31	D32
S9	D33	D34	D35	D36
S10	D37	D38	D39	D40
S11	D41	D42	D43	D44
S12	D45	D46	D47	D48
S13	D49	D50	D51	D52
S14	D53	D54	D55	D56
S15	D57	D58	D59	D60
S16	D61	D62	D63	D64
S17	D65	D66	D67	D68
S18	D69	D70	D71	D72
S19	D73	D74	D75	D76
S20	D77	D78	D79	D80
S21	D81	D82	D83	D84
S22	D85	D86	D87	D88
S23	D89	D90	D91	D92
S24	D93	D94	D95	D96
S25	D97	D98	D99	D100
S26	D101	D102	D103	D104
S27	D105	D106	D107	D108

Output pad	COM1	COM2	COM3	COM4
S28	D109	D110	D111	D112
S29	D113	D114	D115	D116
S30	D117	D118	D119	D120
S31	D121	D122	D123	D124
S32	D125	D126	D127	D128
S33	D129	D130	D131	D132
S34	D133	D134	D135	D136
S35	D137	D138	D139	D140
S36	D141	D142	D143	D144
S37	D145	D146	D147	D148
S38	D149	D150	D151	D152
S39	D153	D154	D155	D156
S40	D157	D158	D159	D160
S41	D161	D162	D163	D164
S42	D165	D166	D167	D168
S43	D169	D170	D171	D172
S44	D173	D174	D175	D176
S45	D177	D178	D179	D180
S46	D181	D182	D183	D184
S47	D185	D186	D187	D188
S48	D189	D190	D191	D192
S49	D193	D194	D195	D196
S50	D197	D198	D199	D200
S51	-	-	-	-
S52	D201	D202	D203	D204
S53	D205	D206	D207	D208

(Note) In external clock operating mode, S53 pad outputs V_{SS} level. When DN is "0", S52 pad and S53 pad output V_{SS} level. When duty is 1/4, S51 pad outputs V_{SS} level.

For example, the table below lists the output states for the S21 output pad.

Display data				Output pad (S21) state
D81	D82	D83	D84	
0	0	0	0	The LCD segments corresponding to COM1, COM2, COM3, and COM4 are off.
0	0	0	1	The LCD segment corresponding to COM4 is on.
0	0	1	0	The LCD segment corresponding to COM3 is on.
0	0	1	1	The LCD segments corresponding to COM3 and COM4 are on.
0	1	0	0	The LCD segment corresponding to COM2 is on.
0	1	0	1	The LCD segments corresponding to COM2 and COM4 are on.
0	1	1	0	The LCD segments corresponding to COM2 and COM3 are on.
0	1	1	1	The LCD segments corresponding to COM2, COM3, and COM4 are on.
1	0	0	0	The LCD segment corresponding to COM1 is on.
1	0	0	1	The LCD segments corresponding to COM1 and COM4 are on.
1	0	1	0	The LCD segments corresponding to COM1 and COM3 are on.
1	0	1	1	The LCD segments corresponding to COM1, COM3, and COM4 are on.
1	1	0	0	The LCD segments corresponding to COM1 and COM2 are on.
1	1	0	1	The LCD segments corresponding to COM1, COM2, and COM4 are on.
1	1	1	0	The LCD segments corresponding to COM1, COM2, and COM3 are on.
1	1	1	1	The LCD segments corresponding to COM1, COM2, COM3, and COM4 are on.

LC450029PKB

Display Data and Output Pad Correspondence (1/3 Duty)

Output pad	COM1	COM2	COM3	Output pad	COM1	COM2	COM3
S1	D1	D2	D3	S28	D82	D83	D84
S2	D4	D5	D6	S29	D85	D86	D87
S3	D7	D8	D9	S30	D88	D89	D90
S4	D10	D11	D12	S31	D91	D92	D93
S5	D13	D14	D15	S32	D94	D95	D96
S6	D16	D17	D18	S33	D97	D98	D99
S7	D19	D20	D21	S34	D100	D101	D102
S8	D22	D23	D24	S35	D103	D104	D105
S9	D25	D26	D27	S36	D106	D107	D108
S10	D28	D29	D30	S37	D109	D110	D111
S11	D31	D32	D33	S38	D112	D113	D114
S12	D34	D35	D36	S39	D115	D116	D117
S13	D37	D38	D39	S40	D118	D119	D120
S14	D40	D41	D42	S41	D121	D122	D123
S15	D43	D44	D45	S42	D124	D125	D126
S16	D46	D47	D48	S43	D127	D128	D129
S17	D49	D50	D51	S44	D130	D131	D132
S18	D52	D53	D54	S45	D133	D134	D135
S19	D55	D56	D57	S46	D136	D137	D138
S20	D58	D59	D60	S47	D139	D140	D141
S21	D61	D62	D63	S48	D142	D143	D144
S22	D64	D65	D66	S49	D145	D146	D147
S23	D67	D68	D69	S50	D148	D149	D150
S24	D70	D71	D72	S51	D151	D152	D153
S25	D73	D74	D75	S52	D154	D155	D156
S26	D76	D77	D78	S53	D157	D158	D159
S27	D79	D80	D81				

(Note) In external clock operating mode, S53 pad outputs V_{SS} level. When DN is "0", S52 pad and S53 pad output V_{SS} level.

For example, the table below lists the output states for the S21 output pad.

Display data			Output pad (S21) state
D61	D62	D63	
0	0	0	The LCD segments corresponding to COM1, COM2, and COM3 are off.
0	0	1	The LCD segment corresponding to COM3 is on.
0	1	0	The LCD segment corresponding to COM2 is on.
0	1	1	The LCD segments corresponding to COM2 and COM3 are on.
1	0	0	The LCD segment corresponding to COM1 is on.
1	0	1	The LCD segments corresponding to COM1 and COM3 are on.
1	1	0	The LCD segments corresponding to COM1 and COM2 are on.
1	1	1	The LCD segments corresponding to COM1, COM2, and COM3 are on.

LC450029PKB

Output Waveforms (1/4-Duty 1/3-Bias Drive Scheme)

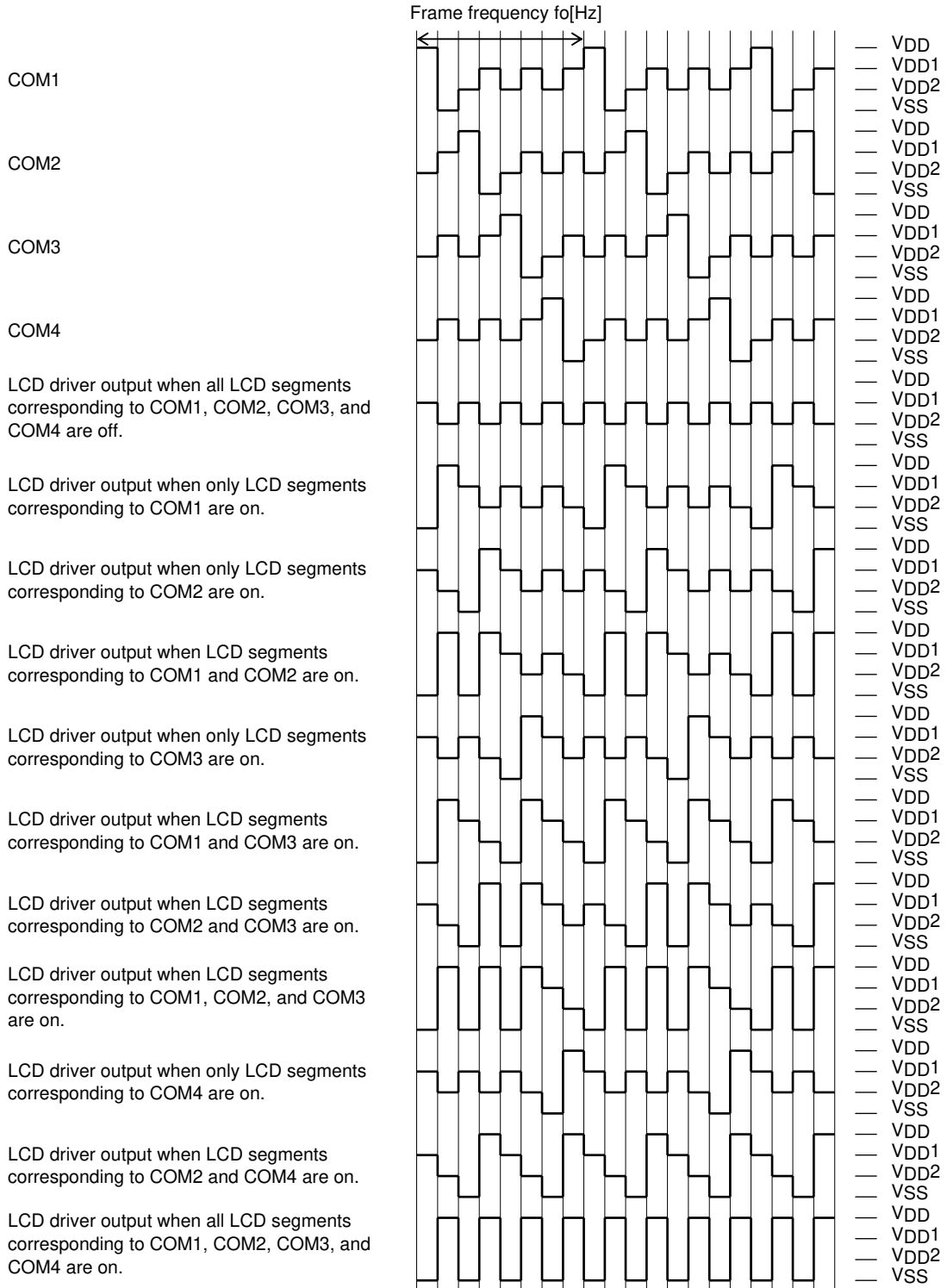

(Note) The frame frequency f_o [Hz] is adjustable by setting control data (EXF, FC0 to FC2 and OC).
 (See "Control Data Functions" for details)

LC450029PKB

Output Waveforms (1/3-Duty 1/3-Bias Drive Scheme)

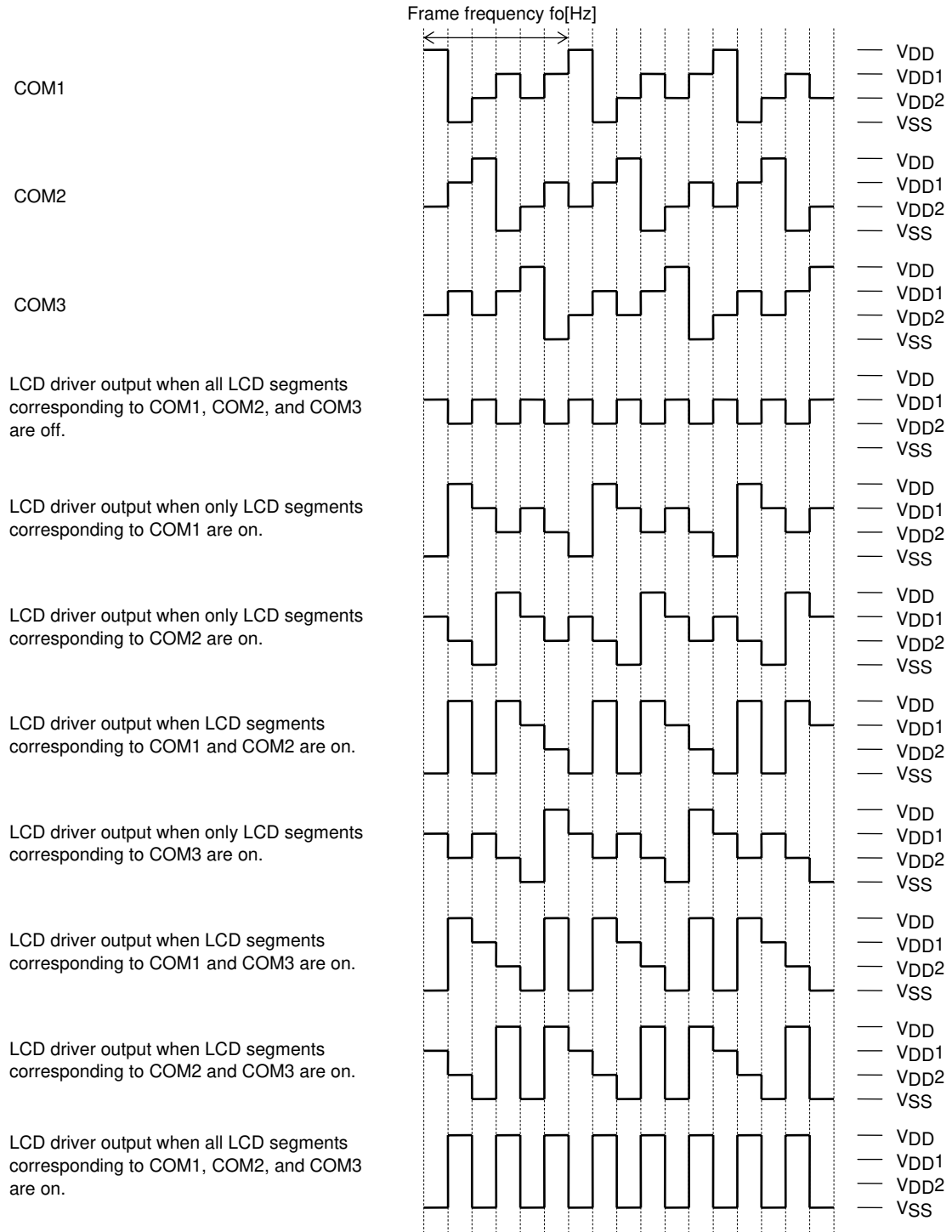

(Note) The frame frequency f_o [Hz] is adjustable by setting control data (EXF, FC0 to FC2 and OC).
 (See "Control Data Functions" for details)

Display Control and the $\overline{\text{INH}}$ Pad

Since the LSI internal data (1/4 duty : the display data D1 to D208 and the control data, 1/3 duty : the display data D1 to D159 and the control data) is undefined when power is first applied. Applications should set the $\overline{\text{INH}}$ pad low at the same time as power is applied to turn off the display (This sets the S1 to S53 and COM1 to COM4 pads the V_{SS} level.) and during this period send serial data from the controller. The controller should then set the $\overline{\text{INH}}$ pad high after the data transfer has completed. This procedure prevents meaningless display at power on. V_{DD} and V_{DDI} are connected with the same power supply. The timing of turn on and turn off for V_{DD} and V_{DDI} should be same time. (See from Figure 5 to Figure 8)

• 1/4 duty

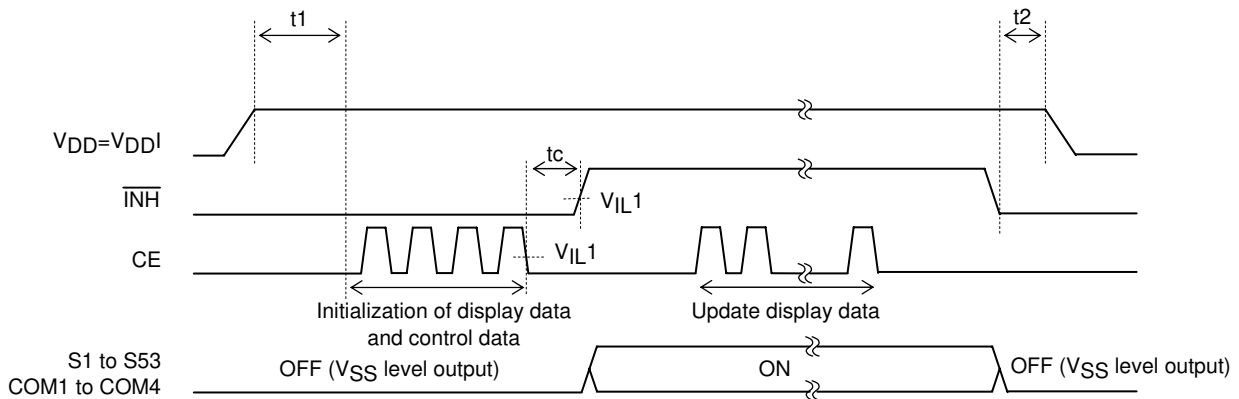

(Note) The wait time (t_1) which power supply turn on should be 1ms or more.
 The discharge time (t_2) of LCD panel's electric charge should be decided the optimum value according to the characteristic of the LCD panel.
 The switching time (t_c) of $\overline{\text{INH}}$ should be 10 μ s or more.

[Figure 5]

• 1/3 duty

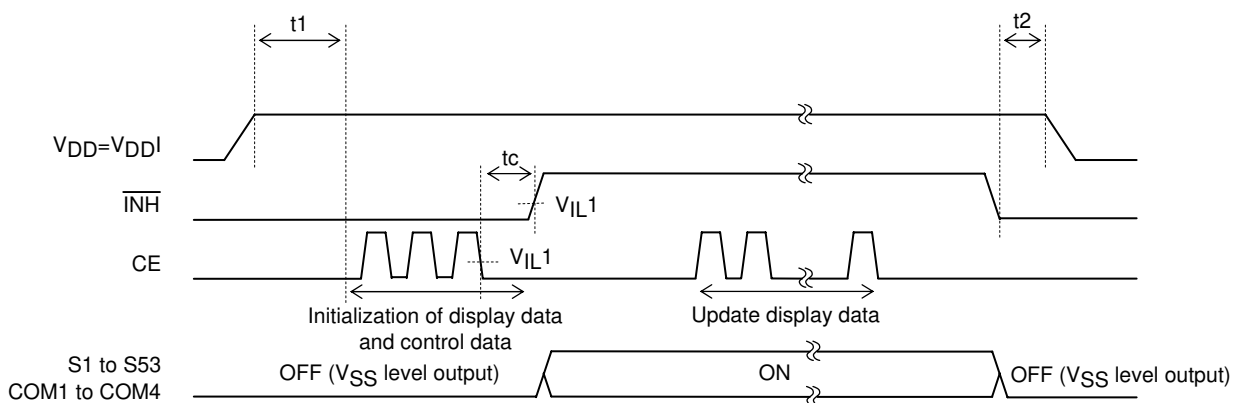

(Note) The wait time (t_1) which power supply turn on should be 1ms or more.
 The discharge time (t_2) of LCD panel's electric charge should be decided the optimum value according to the characteristic of the LCD panel.
 The switching time (t_c) of $\overline{\text{INH}}$ should be 10 μ s or more.

[Figure 6]

LC450029PKB

• In external clock operating mode

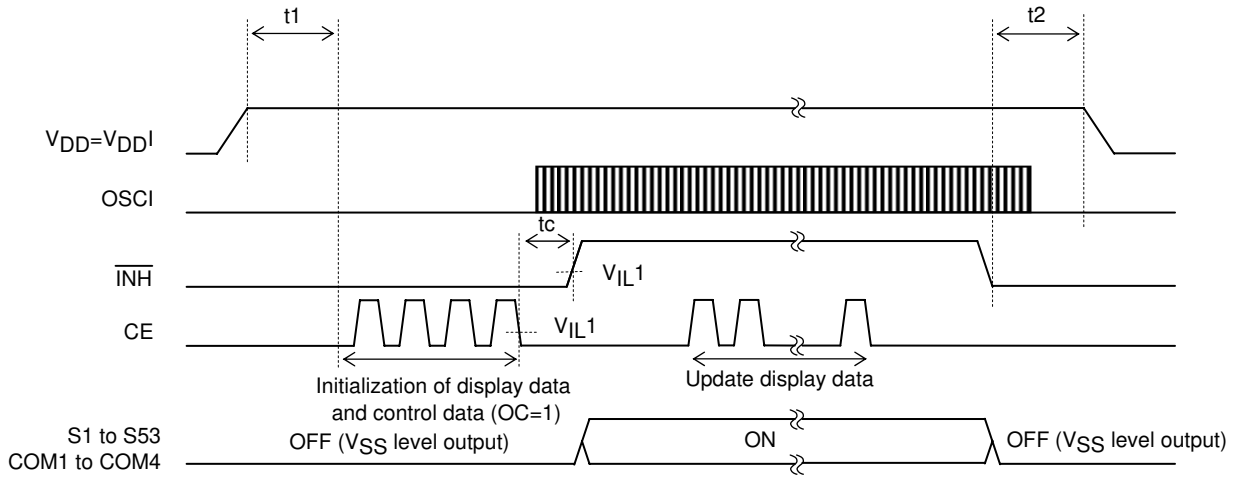

(Note) The wait time (t1) which power supply turn on should be 1ms or more.
 The discharge time (t2) of LCD panel's electric charge should be decided the optimum value according to the characteristic of the LCD panel.
 The switching time (tc) of INH should be 10μs or more.
 OSCI pad should be input an external clock at INH is high level.

[Figure 7]

• All segments off (off waveforms output)

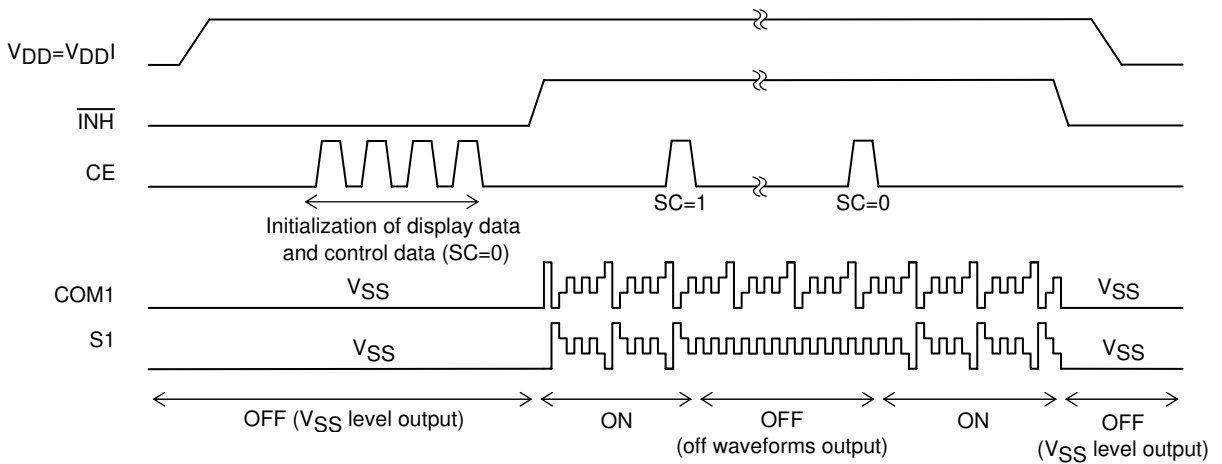

[Figure 8]

• Power-saving mode

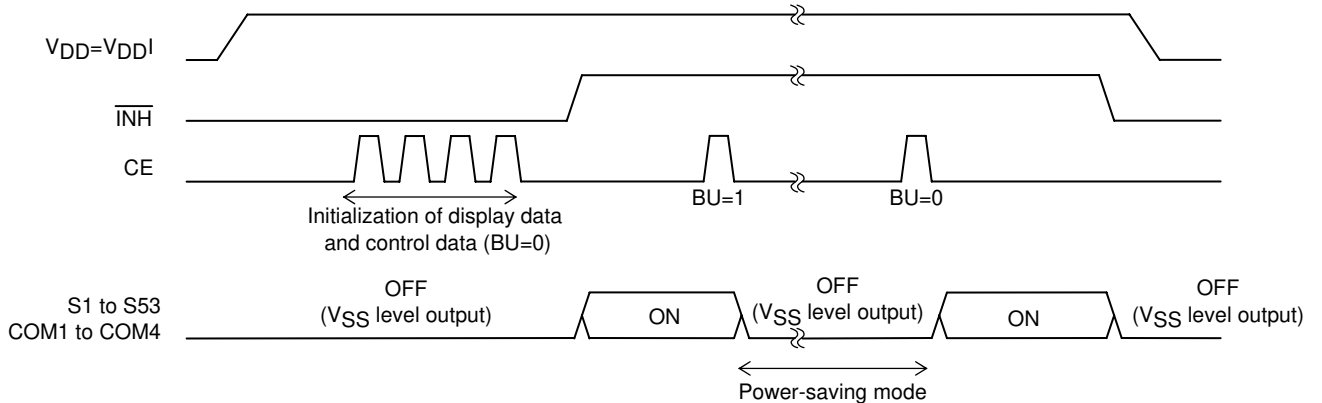

[Figure 9]

Notes on Controller Transfer of Display Data

When using the LC450029PKB in 1/4 duty, applications transfer the display data (D1 to D208) in four operations, and in 1/3 duty, they transfer the display data (D1 to D159) in three operations. In either case, applications should transfer all of the display data within 30ms to maintain the quality of displayed image.

About peripheral circuit of the input pad

(1) Processing of unused OSCI pad

When OSCI pad is not to be used, select the internal oscillator operating mode (control data OC="0"), and OSCI pad is connected to GND.

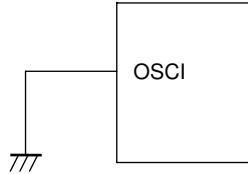

LC450029PKB

Sample Applications Circuit1

1/4 duty, Display data (D1 to D208), Internal oscillator operating mode

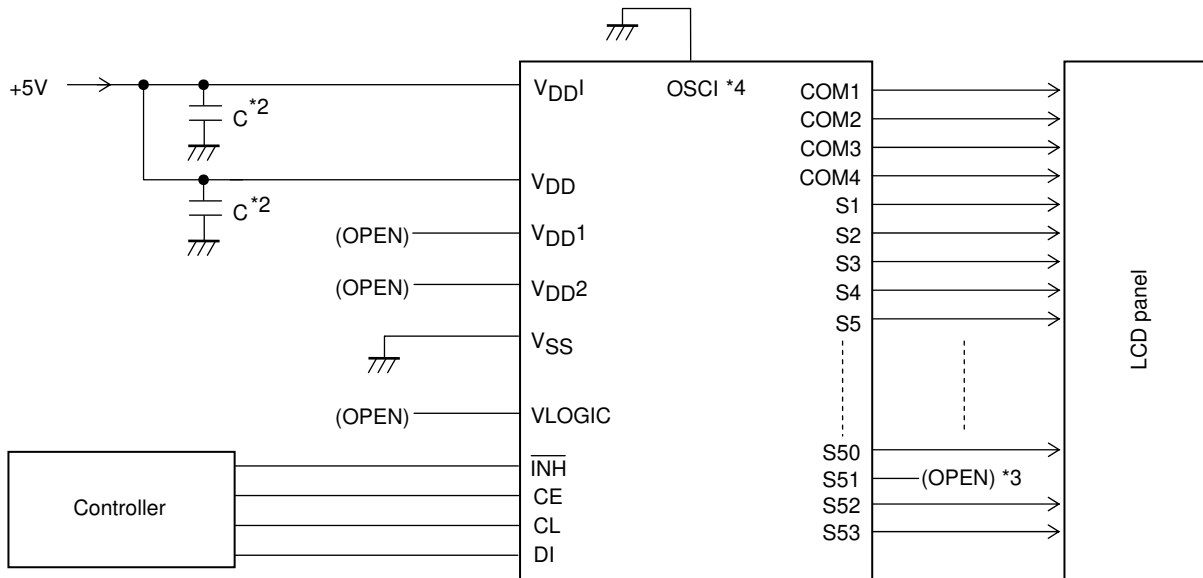

Sample Applications Circuit2

1/4 duty, Display data (D1 to D204), External clock operating mode

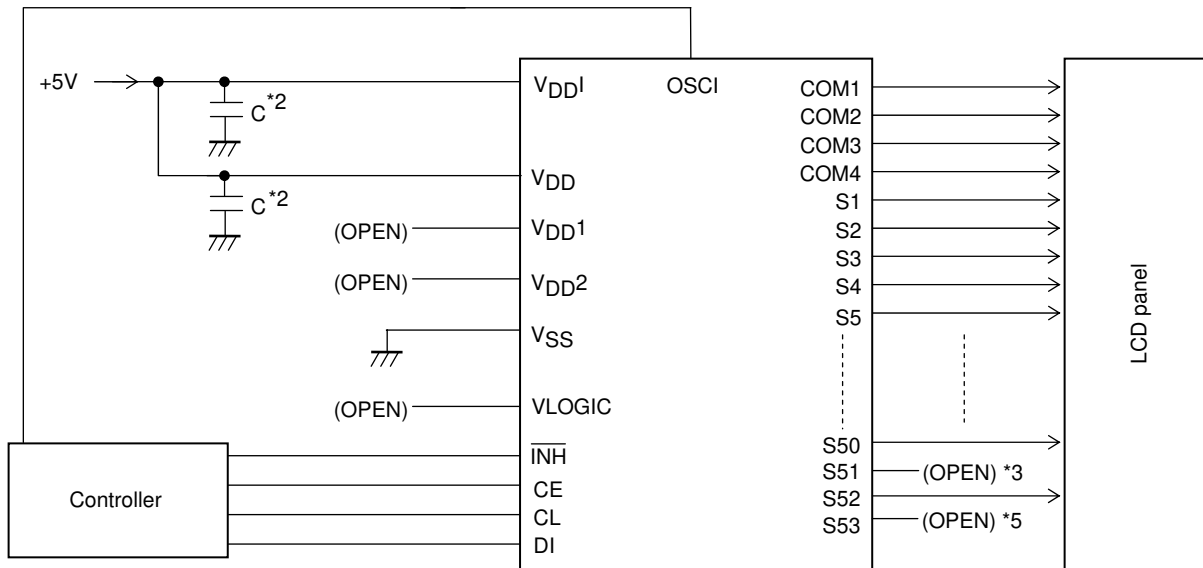

*2 Connect capacitors between a power supply line and GND for noise removal and power supply stabilization.

Determine the value of a capacitor, after an actual circuit board estimates.

*3 In 1/4 duty, S51 pad outputs V_{SS} level.

*4 When OSCI pad is not to be used, select the internal oscillator operating mode (control data OC="0"), and OSCI pad is connected to GND.

*5 In external clock operating mode, S53 pad outputs V_{SS} level.

LC450029PKB

Sample Applications Circuit3

1/3 duty, Display data (D1 to D159), Internal oscillator operating mode

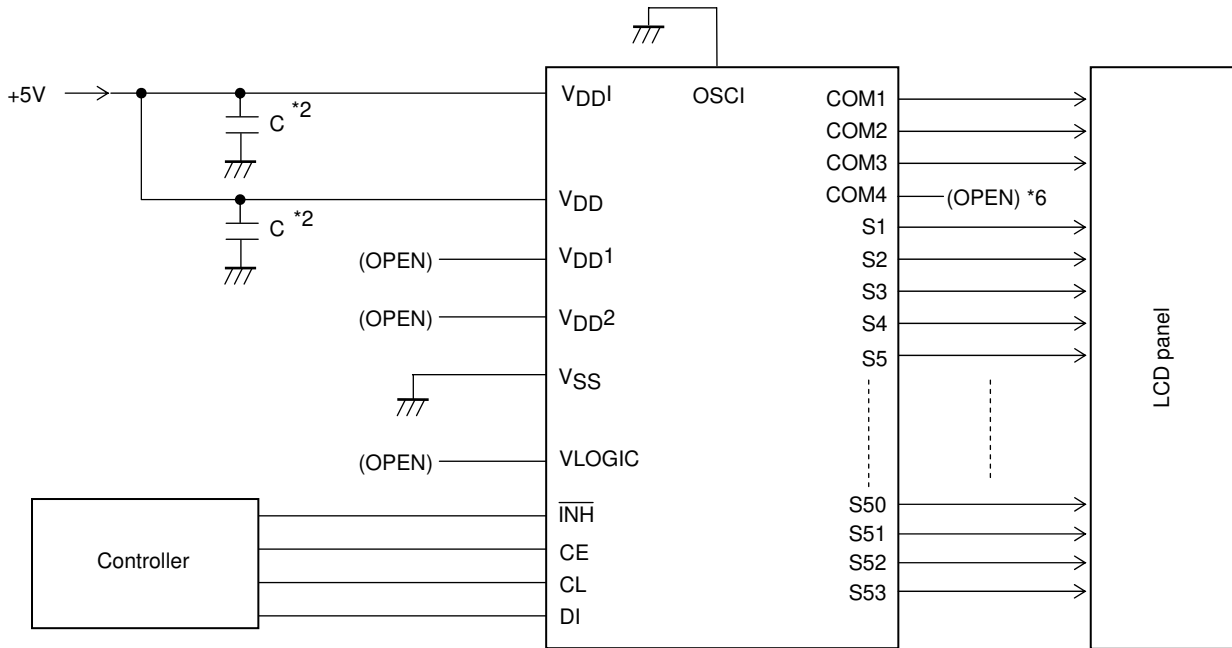

*2 Connect capacitors between a power supply line and GND for noise removal and power supply stabilization.

Determine the value of a capacitor, after an actual circuit board estimates.

*6 In 1/3 duty, COM4 pad outputs V_{SS} level.

The Notes on Use

Important things for stability operation of IC are shown as follows. The contents indicated below do not guarantee IC operation and the characteristic. Moreover, the example of an application circuit written in these specifications is for explaining internal operation and usage. Therefore, please perform the design in consideration of the specification of operation and terms and conditions in the actual LCD panel.

(1) The design of power supply

All power supply pads are connected to the power supply, and do not set open.

(2) ITO (Indium Tin Oxide) wiring

By designing the wire of power supply (V_{DD} , V_{DDI} , V_{SS}) wide and short, make the parasitic resistance of ITO wiring into the minimum.

(3) Signal wiring and connection

The DUMMY pad does not connect to anywhere, and sets open.

(4) Processing of unused input pad

For CMOS process, if an input pad is in open state, operation of IC may become unstable, or unnecessary power supply current may flow through it. Please be sure to connect the empty pad of a logic input to V_{SS} .

(5) The measure against shading

The optical irradiation to IC causes the mis-operation of IC. When IC is implemented, take the measures against shading about the surface, back and side of IC.

LC450029PKB

• PAD Locations (Bump Side View)

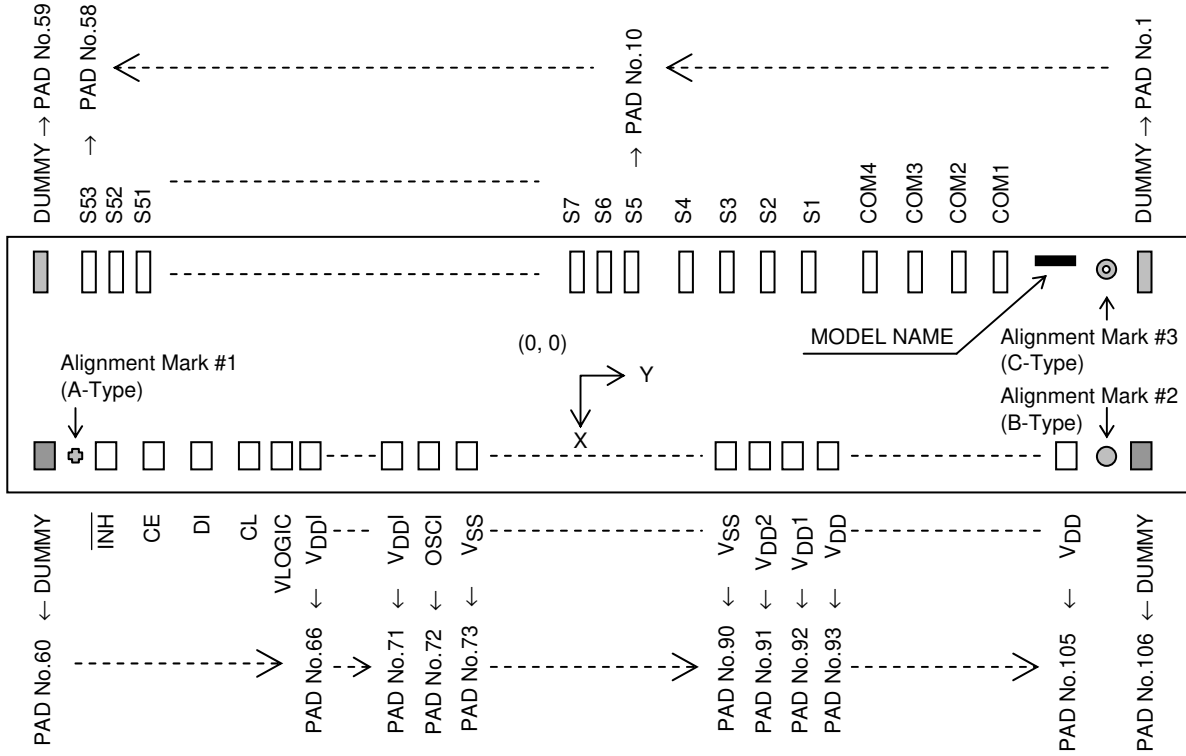

- Chip dimensions (X, Y, S are based on the dicing center.)
 $X=1.00\text{mm}$ $Y=4.08\text{mm}$ $S=4.08\text{mm}^2$ Wafer thickness=400 μm (typ)

• Au Bump dimensions (typ)

Item	PAD No.	Size		
		X [μm]	Y [μm]	S [μm^2]
Bump Size	1 to 59	108	27	2916
	60 to 106	68	42	2856
Min. Bump Pitch	10 to 58	50		-
	1 to 9, 59 to 106	-		-
Min. Bump Clearance	10 to 58, 66 to 71, 73 to 90, 93 to 105	23		-
	1 to 9, 59 to 65, 72, 91 to 92, 106	-		-
Bump Height	All pads	17		-

• Alignment marks

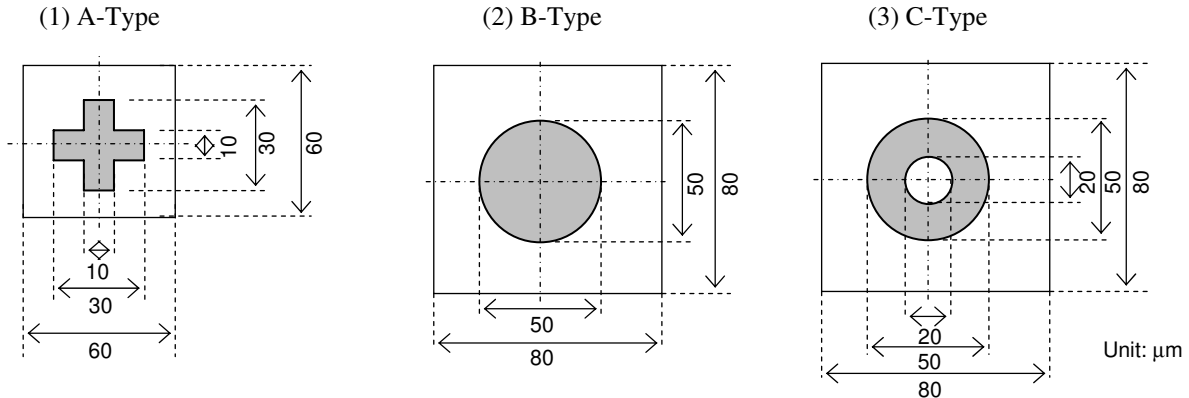

LC450029PKB

• Center coordinates of PADs

(All x/y coordinates represent the position of the center of each PAD)

PAD No.	PAD Name	X [μm]	Y [μm]
1	DUMMY	-380	1950
2	COM1	-380	1369
3	COM2	-380	1276
4	COM3	-380	1183
5	COM4	-380	1090
6	S1	-380	932
7	S2	-380	856
8	S3	-380	780
9	S4	-380	704
10	S5	-380	607
11	S6	-380	557
12	S7	-380	507
13	S8	-380	457
14	S9	-380	407
15	S10	-380	357
16	S11	-380	307
17	S12	-380	257
18	S13	-380	207
19	S14	-380	157
20	S15	-380	107
21	S16	-380	57
22	S17	-380	7
23	S18	-380	-43
24	S19	-380	-93
25	S20	-380	-143
26	S21	-380	-193
27	S22	-380	-243
28	S23	-380	-293
29	S24	-380	-343
30	S25	-380	-393
31	S26	-380	-443
32	S27	-380	-493
33	S28	-380	-543
34	S29	-380	-593
35	S30	-380	-643
36	S31	-380	-693
37	S32	-380	-743
38	S33	-380	-793
39	S34	-380	-843
40	S35	-380	-893

PAD No.	PAD Name	X [μm]	Y [μm]
41	S36	-380	-943
42	S37	-380	-993
43	S38	-380	-1043
44	S39	-380	-1093
45	S40	-380	-1143
46	S41	-380	-1193
47	S42	-380	-1243
48	S43	-380	-1293
49	S44	-380	-1343
50	S45	-380	-1393
51	S46	-380	-1443
52	S47	-380	-1493
53	S48	-380	-1543
54	S49	-380	-1593
55	S50	-380	-1643
56	S51	-380	-1693
57	S52	-380	-1743
58	S53	-380	-1793
59	DUMMY	-380	-1950
60	DUMMY	400	-1943
61	$\overline{\text{INH}}$	400	-1665
62	CE	400	-1525
63	DI	400	-1385
64	CL	400	-1245
65	VLOGIC	400	-1161
66	VDDI	400	-1071
67	VDDI	400	-1006
68	VDDI	400	-941
69	VDDI	400	-876
70	VDDI	400	-811
71	VDDI	400	-746
72	OSCI	400	-650
73	VSS	400	-510
74	VSS	400	-445
75	VSS	400	-380
76	VSS	400	-315
77	VSS	400	-250
78	VSS	400	-185
79	VSS	400	-120
80	VSS	400	-55

PAD No.	PAD Name	X [μm]	Y [μm]
81	VSS	400	10
82	VSS	400	75
83	VSS	400	140
84	VSS	400	205
85	VSS	400	270
86	VSS	400	335
87	VSS	400	400
88	VSS	400	465
89	VSS	400	530
90	VSS	400	595
91	VDD2	400	668
92	VDD1	400	739
93	VDD	400	811
94	VDD	400	876
95	VDD	400	941
96	VDD	400	1006
97	VDD	400	1071
98	VDD	400	1136
99	VDD	400	1201
100	VDD	400	1266
101	VDD	400	1331
102	VDD	400	1396
103	VDD	400	1461
104	VDD	400	1526
105	VDD	400	1591
106	DUMMY	400	1943

• Center coordinates of alignment marks

(All x/y coordinates represent the position of the center of each alignment mark)

Alignment mark	TYPE	X [μm]	Y [μm]
1	A	400	-1800
2	B	400	1790
3	C	-380	1800

ON Semiconductor and the ON logo are registered trademarks of Semiconductor Components Industries, LLC (SCILLC). SCILLC owns the rights to a number of patents, trademarks, copyrights, trade secrets, and other intellectual property. A listing of SCILLC's product/patent coverage may be accessed at www.onsemi.com/site/pdf/Patent-Marking.pdf. SCILLC reserves the right to make changes without further notice to any products herein. SCILLC makes no warranty, representation or guarantee regarding the suitability of its products for any particular purpose, nor does SCILLC assume any liability arising out of the application or use of any product or circuit, and specifically disclaims any and all liability, including without limitation special, consequential or incidental damages. "Typical" parameters which may be provided in SCILLC data sheets and/or specifications can and do vary in different applications and actual performance may vary over time. All operating parameters, including "Typicals" must be validated for each customer application by customer's technical experts. SCILLC does not convey any license under its patent rights nor the rights of others. SCILLC products are not designed, intended, or authorized for use as components in systems intended for surgical implant into the body, or other applications intended to support or sustain life, or for any other application in which the failure of the SCILLC product could create a situation where personal injury or death may occur. Should Buyer purchase or use SCILLC products for any such unintended or unauthorized application, Buyer shall indemnify and hold SCILLC and its officers, employees, subsidiaries, affiliates, and distributors harmless against all claims, costs, damages, and expenses, and reasonable attorney fees arising out of, directly or indirectly, any claim of personal injury or death associated with such unintended or unauthorized use, even if such claim alleges that SCILLC was negligent regarding the design or manufacture of the part. SCILLC is an Equal Opportunity/Affirmative Action Employer. This literature is subject to all applicable copyright laws and is not for resale in any manner.