

THIS COPY IS PROVIDED ON A RESTRICTED BASIS AND IS NOT TO BE USED IN ANY WAY DETRIMENTAL TO THE INTERESTS OF PANDUIT CORP.

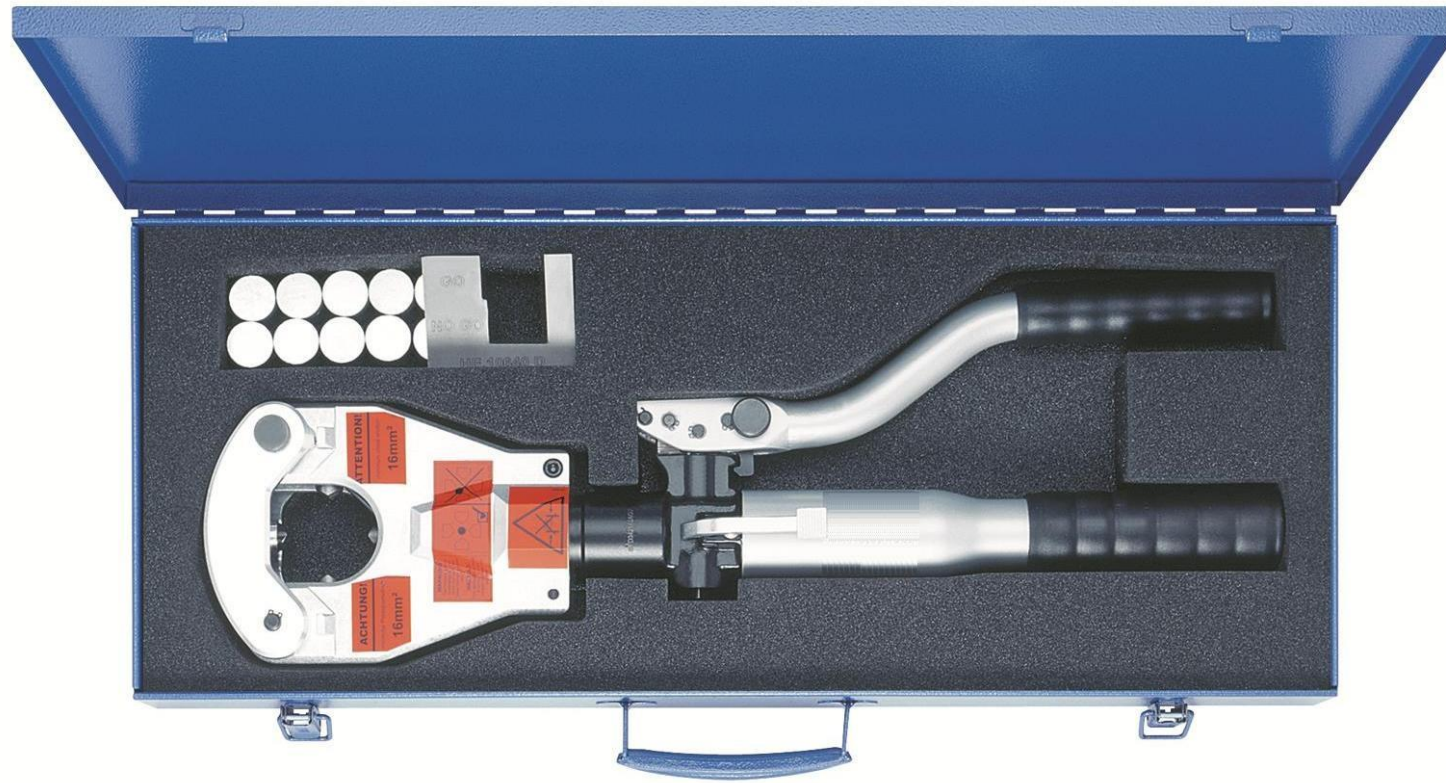

NOTES, UNLESS OTHERWISE SPECIFIED:

The CT-980 Hand Operated Die-less Hydraulic Crimping Tool is designed to crimp:

- Crimps Panduit Copper and Aluminum compression connectors. Go to www.panduit.com for more information.

The CT-980 Tool includes:

Qty.	Description / Item
1	Hand Operated Hydraulic Crimp Tool
1	Steel Tool Case
1	Cylinder Block and Gage Package

Technical Information:

Tool Weight	9.1 lbs. (4.1 kg)
Dimensions	20.7" L x 7.9" H x 2.9" W [525 L x 200 H x 74 W] mm
Crimping Force	6.2 tons (55 kN)

Copy of the operation manual and accessory information can be found at: www.panduit.com.

Dimensions in [brackets] are in millimeters. All dimensions are for reference only.

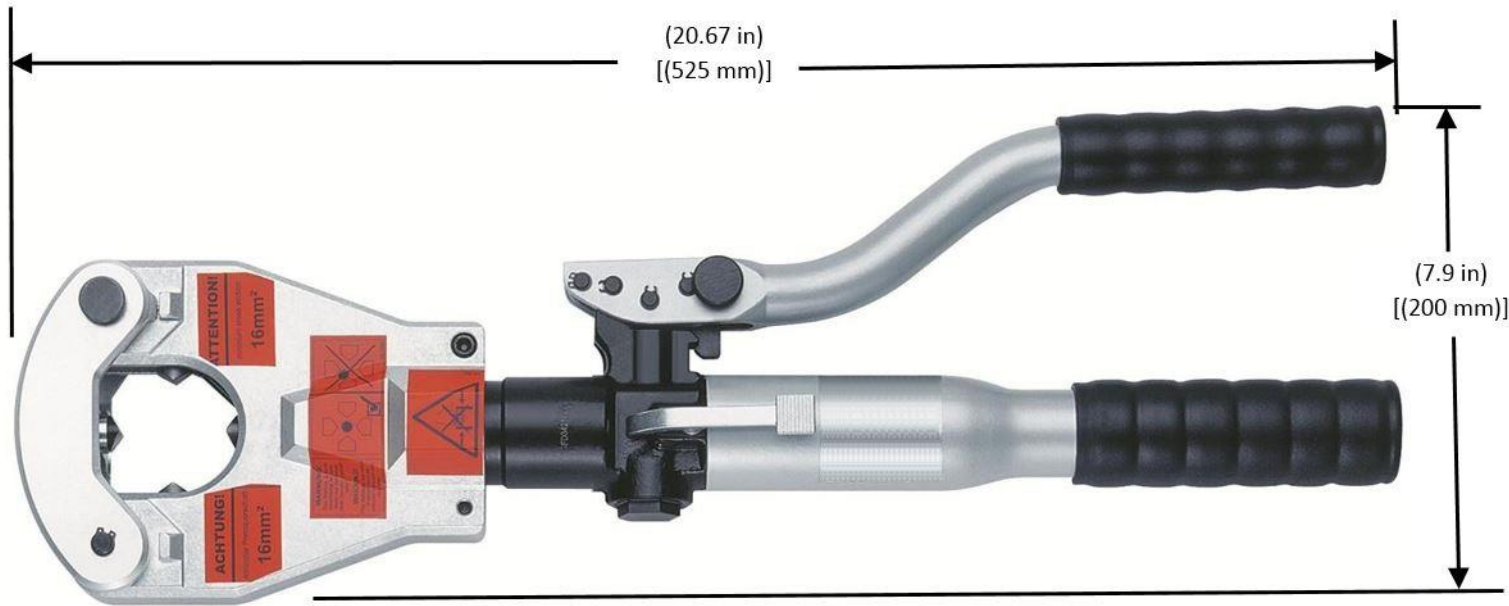

CT-980
CRIMP TOOL

REV	DATE	BY	CHK	APR	DESCRIPTION	ECN	CT-980					
							CUSTOMER DRAWING					
							ITEM REVISION NAME: 00084SLR_DC/00		PANDUIT			
							UNLESS OTHERWISE SPECIFIED, DIMENSIONAL TOLERANCES ARE: (.x) ± --- (.xxx) ± --- (.xx) ± --- ANGLES ± ---					MATERIAL: -----
00	7-29-16	BKA	ACC	JADE	DRAWING RELEASED	010062	THIRD ANGLE PROJECTION		DRAWING NUMBER: 00084SLR_DC			
							DRAWN BY: BKA	DATE: 7-21-16	CHK ACC	SCALE NONE	SHT 1 OF 1	SIZE B