

DM74LS293 4-Bit Binary Counter

General Description

The 'LS293 counter is electrically and functionally identical to the 'LS93. Only the arrangement of the terminals has been changed for the 'LS293.

Each of these monolithic counters contains four master-slave flip-flops and additional gating to provide a divide-by-two counter and a three-stage binary counter for which the count cycle length is divide-by-eight.

All of these counters have a gated zero reset.

To use the maximum count length (four-bit binary) of these counters, the B input is connected to the Q_A output. The input count pulses are applied to input A and the outputs are as described in the appropriate function table.

Features

- GND and V_{CC} on Corner Pins (Pins 7 and 14 respectively)
- Typical power dissipation 45 mW
- Count frequency 42 MHz

Connection Diagram

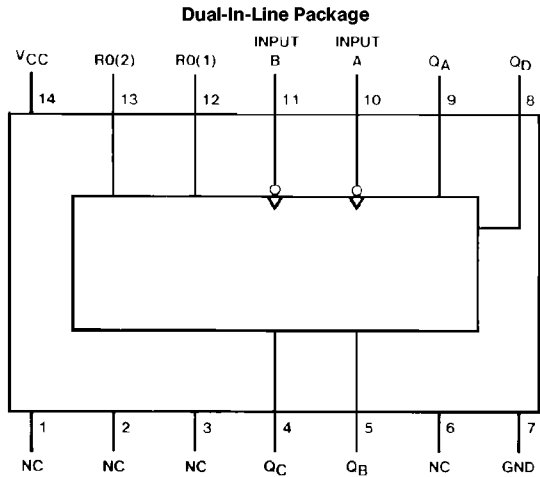

TL/F/6423-1

Order Number DM74LS293M or DM74LS293N
See NS Package Number M14A or N14A

Absolute Maximum Ratings (Note)

If Military/Aerospace specified devices are required, please contact the National Semiconductor Sales Office/Distributors for availability and specifications.

Supply Voltage	7V
Input Voltage	7V
Operating Free Air Temperature Range	0°C to +70°C
DM74LS	0°C to +70°C
Storage Temperature Range	-65°C to +150°C

Note: The "Absolute Maximum Ratings" are those values beyond which the safety of the device cannot be guaranteed. The device should not be operated at these limits. The parametric values defined in the "Electrical Characteristics" table are not guaranteed at the absolute maximum ratings. The "Recommended Operating Conditions" table will define the conditions for actual device operation.

Recommended Operating Conditions

Symbol	Parameter	DM74LS293			Units
		Min	Nom	Max	
V _{CC}	Supply Voltage	4.75	5	5.25	V
V _{IH}	High Level Input Voltage	2			V
V _{IL}	Low Level Input Voltage			0.8	V
I _{OH}	High Level Output Current			-0.4	mA
I _{OL}	Low Level Output Current			8	mA
f _{CLK}	Clock Frequency (Note 1)	A to Q _A	0	32	MHz
		B to Q _B	0	16	
f _{CLK}	Clock Frequency (Note 2)	A to Q _A	0	20	MHz
		B to Q _B	0	10	
t _w	Pulse Width (Note 6)	A	15		ns
		B	30		
		Reset	15		
t _{REL}	Reset Release Time (Note 6)	25			ns
T _A	Free Air Operating Temperature	0		70	°C

Electrical Characteristics over recommended operating free air temperature range (unless otherwise noted)

Symbol	Parameter	Conditions	Min	Typ (Note 3)	Max	Units
V _I	Input Clamp Voltage	V _{CC} = Min, I _I = -18 mA			-1.5	V
V _{OH}	High Level Output Voltage	V _{CC} = Min, I _{OH} = Max V _{IL} = Max, V _{IH} = Min	2.7	3.4		V
V _{OL}	Low Level Output Voltage	V _{CC} = Min, I _{OL} = Max V _{IL} = Max, V _{IH} = Min		0.35	0.5	V
		I _{OL} = 4 mA, V _{CC} = Min		0.25	0.4	
I _I	Input Current @ Max Input Voltage	V _{CC} = Max V _I = 7V	Reset		0.1	mA
			A		0.2	
			B		0.2	
I _{IH}	High Level Input Current	V _{CC} = Max V _I = 2.7V	Reset		20	μA
			A		40	
			B		40	
I _{IL}	Low Level Input Current	V _{CC} = Max V _I = 0.4V	Reset		-0.4	mA
			A		-2.4	
			B		-1.6	
I _{OS}	Short Circuit Output Current	V _{CC} = Max (Note 4)	-20		-100	mA
I _{CC}	Supply Current	V _{CC} = Max (Note 5)		9	15	mA

Switching Characteristics at $V_{CC} = 5V$ and $T_A = 25^\circ C$ (See Section 1 for Test Waveforms and Output Load)

Symbol	Parameter	From (Input) To (Output)	$R_L = 2\text{ k}\Omega$				Units
			$C_L = 15\text{ pF}$		$C_L = 50\text{ pF}$		
			Min	Max	Min	Max	
t_{MAX}	Maximum Clock Frequency	A to Q_A	32		20		MHz
		B to Q_B	16		10		
t_{PLH}	Propagation Delay Time Low to High Level Output	A to Q_A		16		23	ns
t_{PHL}	Propagation Delay Time High to Low Level Output	A to Q_A		18		30	ns
t_{PLH}	Propagation Delay Time Low to High Level Output	A to Q_D		70		87	ns
t_{PHL}	Propagation Delay Time High to Low Level Output	A to Q_D		70		93	ns
t_{PLH}	Propagation Delay Time Low to High Level Output	B to Q_B		16		23	ns
t_{PHL}	Propagation Delay Time High to Low Level Output	B to Q_B		21		35	ns
t_{PLH}	Propagation Delay Time Low to High Level Output	B to Q_C		32		48	ns
t_{PHL}	Propagation Delay Time High to Low Level Output	B to Q_C		35		53	ns
t_{PLH}	Propagation Delay Time Low to High Level Output	B to Q_D		51		71	ns
t_{PHL}	Propagation Delay Time High to Low Level Output	B to Q_D		51		71	ns
t_{PHL}	Propagation Delay Time High to Low Level Output	SET-0 to Any Q		40		53	ns

Note 1: $C_L = 15\text{ pF}$, $R_L = 2\text{ k}\Omega$, $T_A = 25^\circ C$ and $V_{CC} = 5V$.

Note 2: $C_L = 50\text{ pF}$, $R_L = 2\text{ k}\Omega$, $T_A = 25^\circ C$ and $V_{CC} = 5V$.

Note 3: All typicals are at $V_{CC} = 5V$, $T_A = 25^\circ C$.

Note 4: Not more than one output should be shorted at a time, and the duration should not exceed one second.

Note 5: I_{CC} is measured with all outputs open, both RO inputs grounded following momentary connection to 4.5V and all other inputs grounded.

Note 6: $T_A = 25^\circ C$ and $V_{CC} = 5V$.

Function Tables

Count Sequence (See Note C)

Count	Outputs			
	Q _D	Q _C	Q _B	Q _A
0	L	L	L	L
1	L	L	L	H
2	L	L	H	L
3	L	L	H	H
4	L	H	L	L
5	L	H	L	H
6	L	H	H	L
7	L	H	H	H
8	H	L	L	L
9	H	L	L	H
10	H	L	H	L
11	H	L	H	H
12	H	H	L	L
13	H	H	L	H
14	H	H	H	L
15	H	H	H	H

Reset/Count Truth Table

Reset Inputs		Outputs			
R0(1)	R0(2)	Q _D	Q _C	Q _B	Q _A
H	H	L	L	L	L
L	X	COUNT			
X	L	COUNT			

H = High Level, L = Low Level, X = Don't Care.

Note C: Output Q_A is connected to input B.

Logic Diagram

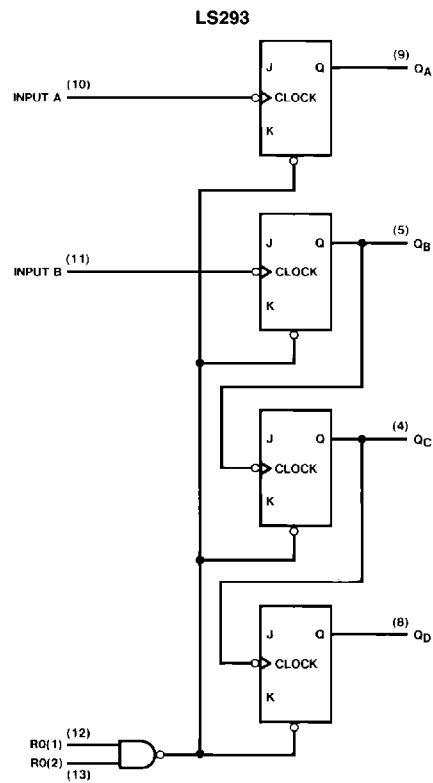

TL/F/6423-2

Note: The J and K inputs shown without connection are for reference only and are functionally at a high level.

Physical Dimensions inches (millimeters)

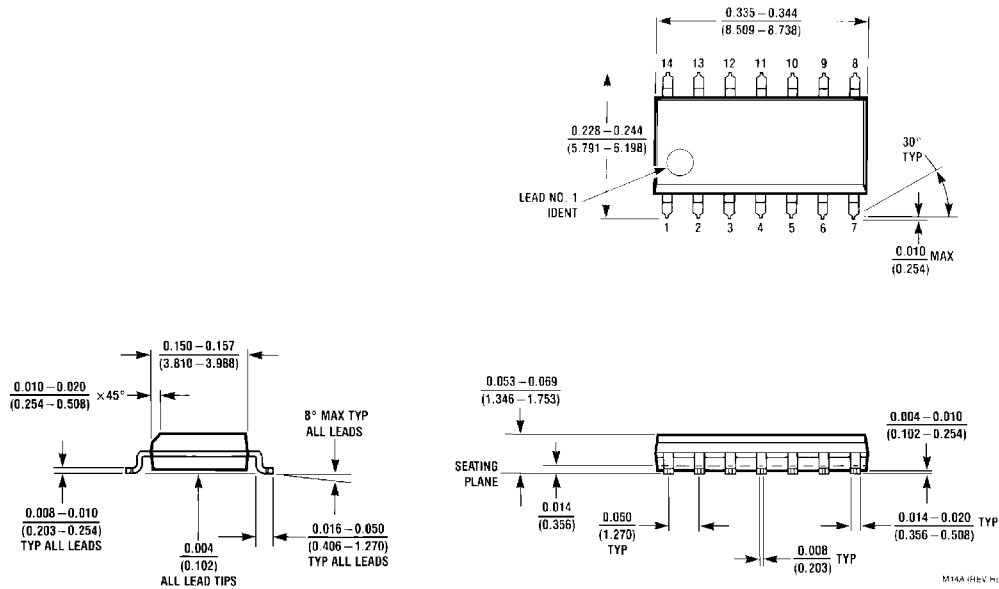

14-Lead Small Outline Molded Package (M)
Order Number DM74LS293M
NS Package Number M14A

M14A (REV. 91)

Physical Dimensions inches (millimeters) (Continued)

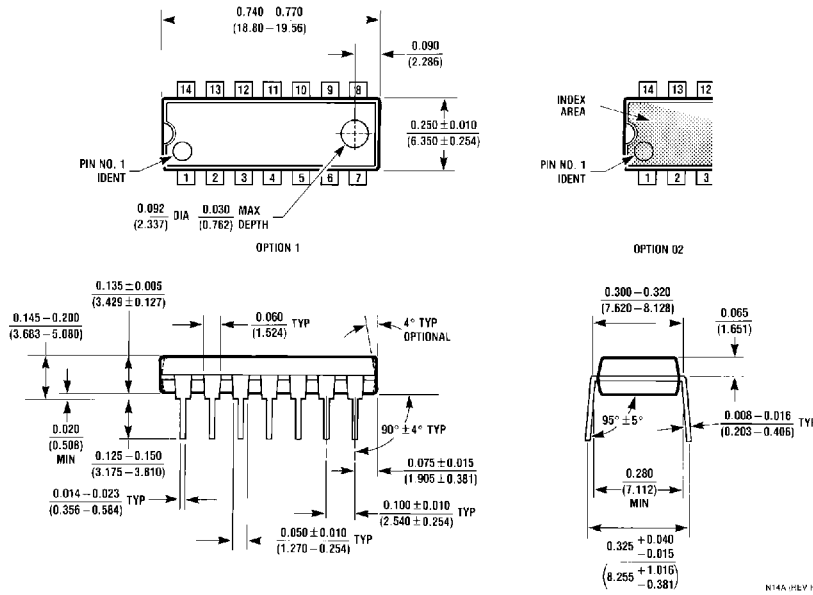

14-Lead Molded Dual-In-Line Package (N)
Order Number DM74LS293N
NS Package Number N14A

LIFE SUPPORT POLICY

NATIONAL'S PRODUCTS ARE NOT AUTHORIZED FOR USE AS CRITICAL COMPONENTS IN LIFE SUPPORT DEVICES OR SYSTEMS WITHOUT THE EXPRESS WRITTEN APPROVAL OF THE PRESIDENT OF NATIONAL SEMICONDUCTOR CORPORATION. As used herein:

1. Life support devices or systems are devices or systems which, (a) are intended for surgical implant into the body, or (b) support or sustain life, and whose failure to perform, when properly used in accordance with instructions for use provided in the labeling, can be reasonably expected to result in a significant injury to the user.
2. A critical component is any component of a life support device or system whose failure to perform can be reasonably expected to cause the failure of the life support device or system, or to affect its safety or effectiveness.



National Semiconductor Corporation
 1111 West Bardin Road
 Arlington, TX 76017
 Tel: 1(800) 272-9959
 Fax: 1(800) 737-7018

National Semiconductor Europe
 Fax: (+49) 0-180-530 85 86
 Email: onjwge@tevm2.nsc.com
 Deutsch Tel: (+49) 0-180-530 85 85
 English Tel: (+49) 0-180-532 78 32
 Français Tel: (+49) 0-180-532 93 58
 Italiano Tel: (+49) 0-180-534 16 80

National Semiconductor Hong Kong Ltd.
 13th Floor, Straight Block,
 Ocean Centre, 5 Canton Rd.
 Tsimshatsui, Kowloon
 Hong Kong
 Tel: (852) 2737-1600
 Fax: (852) 2736-9960

National Semiconductor Japan Ltd.
 Tel: 81-043-299-2309
 Fax: 81-043-299-2408

National does not assume any responsibility for use of any circuitry described, no circuit patent licenses are implied and National reserves the right at any time without notice to change said circuitry and specifications.