

REVISIONS

P	LTR	DESCRIPTION	DATE	DWN	APVD
	I	REVISED	08AUG2021	SJ	CY
	A	REVISED	19AUG2021	SJ	CY

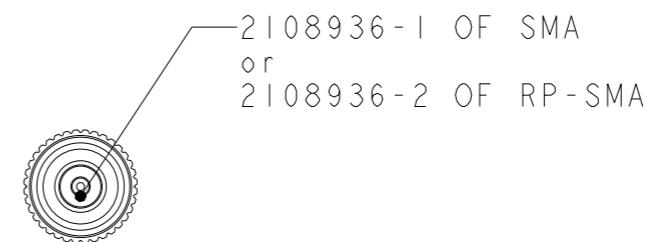
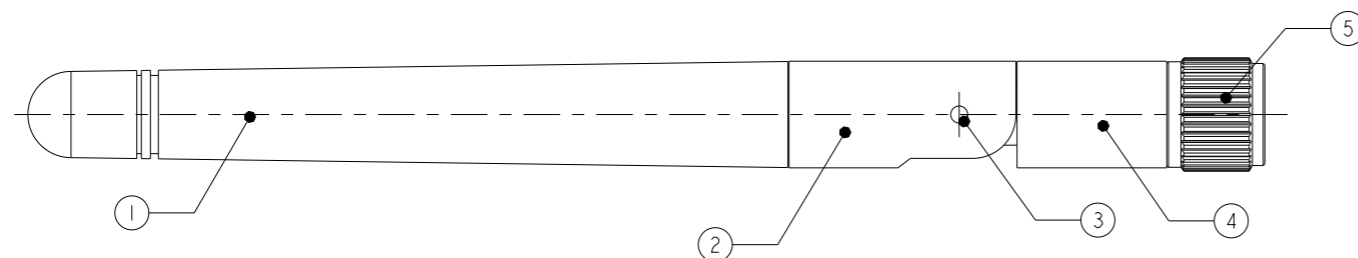
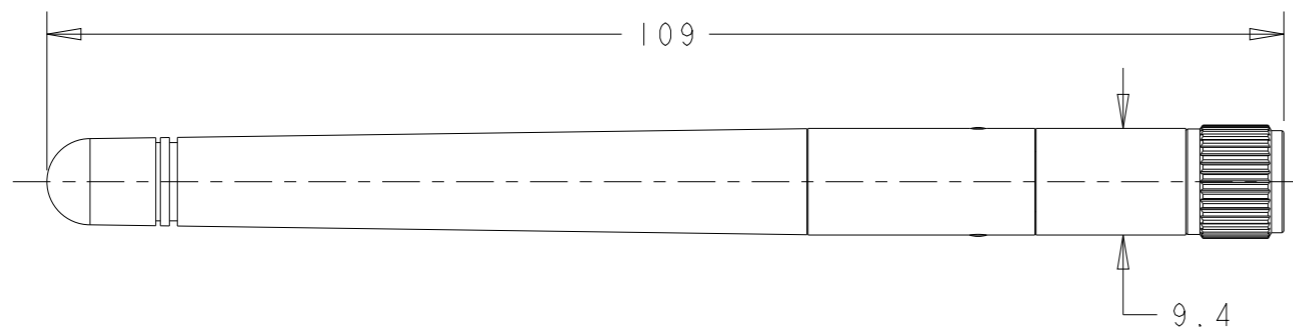

2108936-1 OF SMA  
or  
2108936-2 OF RP-SMA

NOTES

- MATERIAL : SEE TABLE 1.
- PACKAGING : BAG WRAPPED PACKAGE IN BULK.
- SPECIFICATION
  - A. FREQUENCY : 2.4~2.5Ghz & 5.15~5.85Ghz
  - B. VSWR : <=2.0:1
  - C. GAIN 2.4Ghz: 2.2dBi/ 5Ghz : 3.7dBi
  - D. IMPEDANCE : 50 ohm
  - E. POLARIZATION : VERTICAL
  - F. OPERATING TEMP : -30°C TO +70°C
  - STORAGE TEMP : -30°C TO +70°C

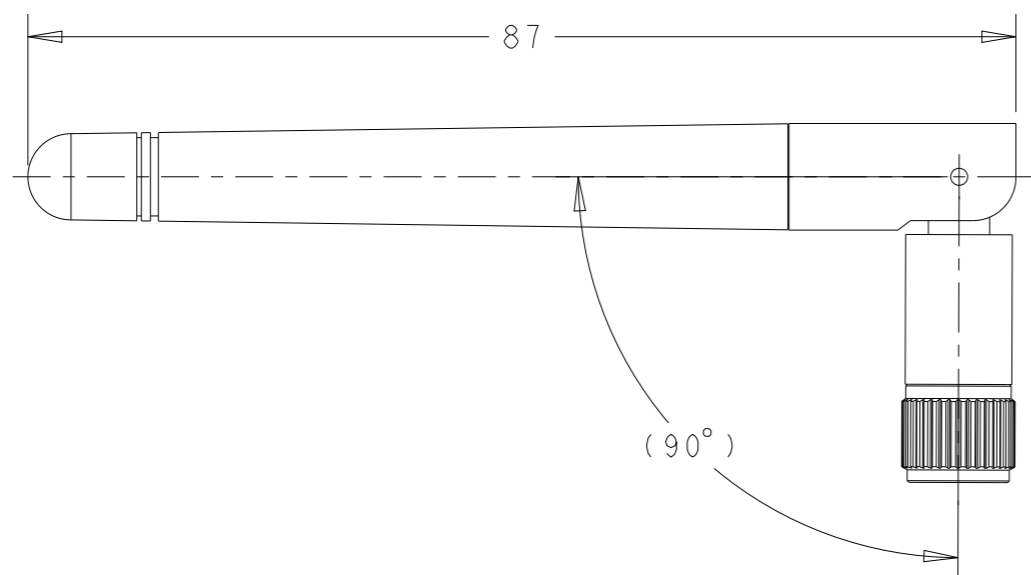

TABLE 1

TE P/Ns	2108936-2	2108936-1				
	1	-	SHELL(BLACK)	RP-SMA PLUG ASSY	CONNECTOR ASSY	5
	-	1	SHELL(BLACK)	SMA PLUG ASSY	CONNECTOR ASSY	5
	1	1	BLACK	ABS	BOTTOM BASE	4
	2	2	BLACK	POM	RIVET	3
	1	1	BLACK	ABS	UPPER BASE	2
	1	1	BLACK	TPEE	ANTENNA CAP	1
	Q'TY	Q'TY	COLOR/FINISH	MATERIAL	DESCRIPTION	ITEM

THIS DRAWING IS A CONTROLLED DOCUMENT.

DWN SJ.NOH 21JUL2021  
CHK H.SHIN 21JUL2021  
APVD CY.PARK 21JUL2021  
PRODUCT SPEC  
APPLICATION SPEC  
WEIGHT -



NAME WLAN Dual Band Terminal Antenna

DIMENSIONS: mm	TOLERANCES UNLESS OTHERWISE SPECIFIED: ±0.1
	0 PLC ±-
	1 PLC ±-
	2 PLC ±-
	3 PLC ±-
	4 PLC ±-
	ANGLES ±-
MATERIAL TBD	FINISH - finish_spec_2

SIZE CAGE CODE DRAWING NO RESTRICTED TO

A300779 C-2108936

CUSTOMER DRAWING SCALE 3:2 SHEET 1 OF 1 REV A