

RoHS Compliant

mSATA Flash Drive

mSATA mini H1-M Product Specifications (Toshiba 15nm)

March 25, 2016

Version 1.2



Apacer Technology Inc.

1F, No.32, Zhongcheng Rd., Tucheng Dist., New Taipei City, Taiwan, R.O.C

Tel: +886-2-2267-8000

Fax: +886-2-2267-2261

www.apacer.com

Features:

- **Compliance with SATA Revision 3.1**
 - SATA 6.0 Gbps interface
 - Backward compatible with SATA 1.5/3.0 Gbps interfaces
 - ATA command set
- **Capacity**
 - 8, 16, 32, 64, 128 GB
- **Performance***
 - Interface burst read/write: 600 MB/sec
 - Sustained read: up to 230 MB/sec
 - Sustained write: up to 160 MB/sec
- **Flash Management**
 - Built-in hardware ECC
 - Wear leveling
 - Bad block management
 - S.M.A.R.T.
 - Power failure management
 - TRIM
- **NAND Flash Type: MLC**
- **Endurance**
 - 8 GB: 7 TBW
 - 16 GB: 14 TBW
 - 32 GB: 28 TBW
 - 64 GB: 57 TBW
 - 128 GB: 114 TBW
- **Temperature Range**
 - Operating:
 - Standard: 0°C to 70°C
 - Extended: -40°C to 85°C
 - Storage: -40°C to 85°C
- **Supply Voltage**
 - 3.3 V ± 5%
- **Power Consumption***
 - Active mode: 520 mA
 - Idle mode: 85 mA
- **Form Factor**
 - mSATA mini, JEDEC MO-300B
 - Dimensions (29.85 x 26.80 x 1.00**, unit: mm)
- **Connector**
 - 52-pin mSATA signal connector
- **Device Sleep (optional)*****
- **RoHS Compliant**

*Varies from capacities. The values addressed here are typical and may vary depending on host system settings.

**Only the height of the PCB

***Not available in 64GB and 128GB models

Table of Contents

1. Product Description	3
1.1 Introduction	3
1.2 Capacity Specifications	3
1.3 Performance	3
1.4 Pin Assignments	4
2. Software Interface	6
2.1 Command Set	6
2.2 S.M.A.R.T.	7
3. Flash Management	8
3.1 Error Correction/Detection	8
3.2 Bad Block Management	8
3.3 Wear Leveling	8
3.4 Power Failure Management.....	8
3.5 TRIM	8
3.6 Secure Erase	8
3.7 SATA Power Management	9
4. Environment Specifications	10
4.1 Environmental	10
4.2 Mean Time Between Failures (MTBF)	10
4.3 Certification and Compliance.....	10
4.4 Endurance	11
5. Electrical Characteristics	12
5.1 Operating Voltage.....	12
5.2 Power Consumption	12
6. Mechanical Specifications.....	13
6.1 Dimensions	13
7. Product Ordering Information	15
7.1 Product Code Designation.....	15
7.2 Valid Combinations	16

1. Product Description

1.1 Introduction

Apacer's mSATA mini H1-M delivers all the advantages of flash disk technology with the Serial ATA 6.0 Gbps interface and is fully compliant with the standard mSATA mini form factor, known as JEDEC MO-300B standard. The module is designed to operate at optimal efficiency and reliability while maintained in super compact form factor. Meanwhile, the power consumption of the mSATA mini module remains at minimal level.

1.2 Capacity Specifications

Table 1-1 Capacity Specifications

Capacity	Total Bytes	Cylinders	Heads	Sectors	Max LBA
8 GB	8,012,390,400	15,525	16	63	15,649,200
16 GB	16,013,942,784	16,383	16	63	31,277,232
32 GB	32,017,047,552	16,383	16	63	62,533,296
64 GB	64,023,257,088	16,383	16	63	125,045,424
128 GB	128,035,676,160	16,383	16	63	250,069,680

*Display of total bytes varies from file systems.

**Cylinders, heads or sectors are not applicable for these capacities. Only LBA addressing applies.

LBA count addressed in the table above indicates total user storage capacity and will remain the same throughout the lifespan of the device. However, the total usable capacity of the SSD is most likely to be less than the total physical capacity because a small portion of the capacity is reserved for device maintenance usages.

1.3 Performance

Performance of mSATA mini H1-M is shown in Table 1-2.

Table 1-2 Performance Specifications

Capacity Performance	8 GB	16 GB	32 GB	64 GB	128 GB
Sustained Read (MB/s)	120	215	230	230	220
Sustained Write (MB/s)	85	150	130	160	125

Note: Performance varies from flash configurations or host system settings.

1.4 Pin Assignments

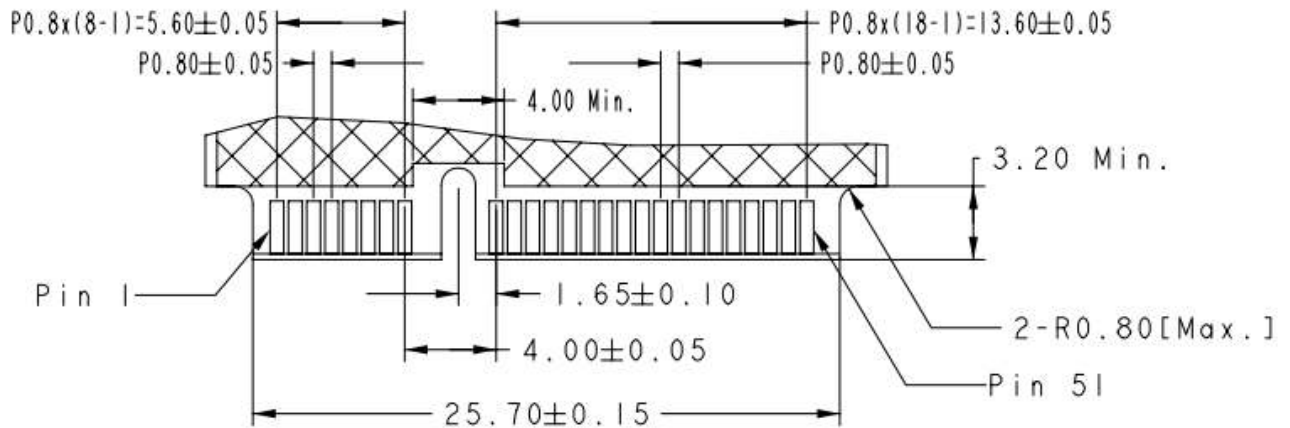

Figure 1-1 Pin Assignment

Table 1-3 Pin Assignment Description

Pin #	mSATA Pin	Description
1	NC	No Connect
2	+3.3V	3.3V Source
3	NC	No Connect
4	DGND	Digital GND
5	NC	No Connect
6	NC	No Connect
7	NC	No Connect
8	NC	No Connect
9	DGND	Digital GND
10	NC	No Connect
11	NC	No Connect
12	NC	No Connect
13	NC	No Connect
14	NC	No Connect
15	DGND	Digital GND
16	NC	No Connect
17	NC	No Connect
18	DGND	Digital GND
19	NC	No Connect
20	NC	No Connect

mSATA Flash Drive

APSDMxxxGN1HN-XTM1X



Pin #	mSATA Pin	Description
21	SATA GND	SATA Ground Return Pin
22	NC	No Connect
23	+B	Host Receiver Differential Signal Pair
24	+3.3V	3.3V Source
25	-B	Host Receiver Differential Signal Pair
26	SATA GND	SATA Ground Return Pin
27	SATA GND	SATA Ground Return Pin
28	NC	No Connect
29	SATA GND	SATA Ground Return Pin
30	NC	No Connect
31	-A	Host Transmitter Differential Signal Pair
32	NC	No Connect
33	+A	Host Transmitter Differential Signal Pair
34	DGND	Digital GND
35	SATA GND	SATA Ground Return Pin
36	NC	No Connect
37	SATA GND	SATA Ground Return Pin
38	NC	No Connect
39	+3.3V	3.3V Source
40	DGND	Digital GND
41	+3.3V	3.3V Source
42	NC	No Connect
43	NC	No Connect
44	NC	No Connect or Device Sleep*
45	Vendor	Vendor specific
46	NC	No Connect
47	Vendor	Vendor specific
48	NC	No Connect
49	DAS	Device activity signal
50	DGND	Digital GND
51	GND	Default connect to GND
52	+3.3V	3.3V Source

*Device Sleep is optional

2. Software Interface

2.1 Command Set

Table 2-1 summarizes the ATA commands supported by mSATA mini H1-M.

Table 2-1 Command Set

Command	Code	Command	Code
NOP	00h	Idle	97h
Data Set Management	06h	Check Power Mode	98h
Recalibrate	10f-1Fh	Sleep	99h
Read Sectors	20h	SMART	B0h
Read Sectors without Retry	21h	Device Configuration	B1h
Read Sectors EXT	24h	Read Multiple	C4h
Read DMA EXT	25h	Write Multiple	C5h
Read Native Max Address EXT	27h	Set Multiple Mode	C6h
Read Multiple EXT	29h	Read DMA	C8h
Read Log EXT	2Fh	Read DMA without Retry	C9h
Write Sectors	30h	Write DMA	CAh
Write Sectors Without Retry	31h	Write DMA without Retry	CBh
Write Sectors EXT	34h	Write Multiple FUA EXT	CEh
Write DMA EXT	35h	Standby Immediate	E0h
Set Native Max Address EXT	37h	Idle Immediate	E1h
CFA Write Sectors without erase	38h	Standby	E2h
Write Multiple EXT	39h	Idle	E3h
Write DMA FUA EXT	3Dh	Read Buffer	E4h
Write Long EXT	3Fh	Check Power Mode	E5h
Read Verify Sectors	40h	Sleep	E6h
Read Verify Sectors without Retry	41h	Flush Cache	E7h
Read Verify Sectors EXT	42h	Write Buffer	E8h
Write Uncorrectable EXT	45h	Flush Cache EXT	EAh
Read FPDMA Queued	60h	Identify Device	ECh
Write FPDMA Queued	61h	Set Features	EFh
Seek	70h-7Fh	Security Set Password	F1h
Execute Device Diagnostic	90h	Security Unlock	F2h
Initialize Device Parameters	91h	Security Erase Prepare	F3h
Download Microcode	92h	Security Erase Unit	F4h
Download Microcode DMA	93h	Security Freeze Lock	F5h
Standby Immediate	94h	Security Disable Password	F6h
Idle Immediate	95h	Read Native Max Address	F8h
Standby	96h	Set Max Address	F9h

Note. Security command will only be workable when device runs in non-OPAL compliant mode.

2.2 S.M.A.R.T.

SMART, an acronym for Self-Monitoring, Analysis and Reporting Technology, is an open standard that allows a hard disk drive to automatically detect its health and report potential failures. When a failure is recorded by SMART, users can choose to replace the drive to prevent unexpected outage or data loss. Moreover, SMART can inform users of impending failures while there is still time to perform proactive actions, such as copy data to another device.

3. Flash Management

3.1 Error Correction/Detection

Flash memory cells will deteriorate with use, which might generate random bit errors in the stored data. Thus, this mSATA SSD module applies the BCH ECC Algorithm, which can detect and correct errors occur during Read process, ensure data been read correctly, as well as protect data from corruption. This device can correct up to 72bit/1K data.

3.2 Bad Block Management

Bad blocks are blocks that include one or more invalid bits, and their reliability is not guaranteed. Blocks that are identified and marked as bad by the manufacturer are referred to as “Initial Bad Blocks”. Bad blocks that are developed during the lifespan of the flash are named “Later Bad Blocks”. Apacer implements an efficient bad block management algorithm to detect the factory-produced bad blocks and manages any bad blocks that appear with use. This practice further prevents data being stored into bad blocks and improves the data reliability.

3.3 Wear Leveling

NAND Flash devices can only undergo a limited number of program/erase cycles, and in most cases, the flash media are not used evenly. If some areas get updated more frequently than others, the lifetime of the device would be reduced significantly. Thus, Wear Leveling technique is applied to extend the lifespan of NAND Flash by evenly distributing write and erase cycles across the media.

Apacer provides advanced Wear Leveling algorithm, which can efficiently spread out the flash usage through the whole flash media area. Moreover, by implementing both dynamic and static Wear Leveling algorithms, the life expectancy of the NAND Flash is greatly improved.

3.4 Power Failure Management

Power Failure Management plays a crucial role when experiencing unstable power supply. Power disruption may occur when users are storing data into the SSD. In this urgent situation, the controller would run multiple flush cycles to store the metadata for later block rebuilding. This urgent operation requires about several milliseconds to get it done. At the next power up, the firmware will perform a status tracking to retrieve the mapping table and resume previously programmed NAND blocks to check if there is any incompleteness of transmission.

3.5 TRIM

TRIM is a feature which helps improve the read/write performance and speed of solid-state drives (SSD). Unlike hard disk drives (HDD), SSDs are not able to overwrite existing data, so the available space gradually becomes smaller with each use. With the TRIM command, the operating system can inform the SSD which blocks of data are no longer in use and can be removed permanently. Thus, the SSD will perform the erase action, which prevents unused data from occupying blocks all the time.

3.6 Secure Erase

Secure Erase is a standard ATA command and will write all “0xFF” to fully wipe all the data on hard drives and SSDs. When this command is issued, the SSD controller will empty its storage blocks and return to its factory default settings.

Note. Secure erase command belongs to ATA security command.

3.7 SATA Power Management

By complying with SATA 6.0 Gb/s specifications, the mSATA SSD supports Device Sleep power state:

- Device Sleep (DevSleep or DEVSLP): PHY powered down; power consumption ≤ 5 mW; host assertion time ≤ 10 ms; exit timeout from this state ≤ 20 ms (unless specified otherwise in SATA Identify Device Log).

Note: Device Sleep mode is optional, depending on product ordering selections.

4. Environment Specifications

4.1 Environmental

Table 4-1 Environmental Specifications

Environment	Specifications
Temperature	0°C to 70°C (Operating); -40°C to 85°C (Extended)
	-40°C to 85°C (Storage)
Shock	1,500G, 0.5ms
Vibration	20Hz~80Hz/1.52mm (frequency/displacement)
	80Hz~2000Hz/20G (frequency/displacement)
	X, Y, Z axis/60mins each
Drop	80cm free fall, 6 face of each
Bending	≥ 50N, hold 1min/5times
Torque	0.5N-m or 5deg, hold 5min/5times
ESD	Pass

Note: Shock and Vibration specifications are subject to change without notice.

4.2 Mean Time Between Failures (MTBF)

MTBF, an acronym for Mean Time Between Failures, is a measure of a device's reliability. Its value represents the average time between a repair and the next failure. The measure is typically in units of hours. The higher the MTBF value, the higher the reliability of the device. The predicted result of this mSATA device is higher than 1,000,000 hours.

4.3 Certification and Compliance

mSATA mini H1-M complies with the following standards:

- SATA Revision 3.1
- RoHS
- ATA/ATAPI
- FCC
- CE
- BSMI
- MIL-STD-810G

4.4 Endurance

The endurance of a storage device is predicted by TeraBytes Written based on several factors related to usage, such as the amount of data written into the drive, block management conditions, and daily workload for the drive. Thus, key factors, such as Write Amplifications and the number of P/E cycles, can influence the lifespan of the drive.

Capacity	TeraBytes Written
8 GB	7
16 GB	14
32 GB	28
64 GB	57
128 GB	114

Note:

- The measurement assumes the data written to the SSD for test is under a typical and constant rate.
- The measurement follows the standard metric: 1 TB (Terabyte) = 1,000 GB.
- The estimated values are based on JEDEC Enterprise endurance workload comprised of random data with the payload size distribution with sequential write behavior.

5. Electrical Characteristics

5.1 Operating Voltage

Table 5-1 lists the supply voltage for mSATA mini H1-M.

Table 5-1 Operating Voltage

Parameter	Conditions
Supply Voltage	3.3V ± 5%

5.2 Power Consumption

Table 5-2 Power Consumption (typical)

Mode \ Capacity	8 GB	16 GB	32 GB	64 GB	128 GB
Active (mA)	350	330	330	520	515
Idle (mA)	85	80	80	80	80

Note: Power consumptions may vary depending on host system settings.

6. Mechanical Specifications

6.1 Dimensions

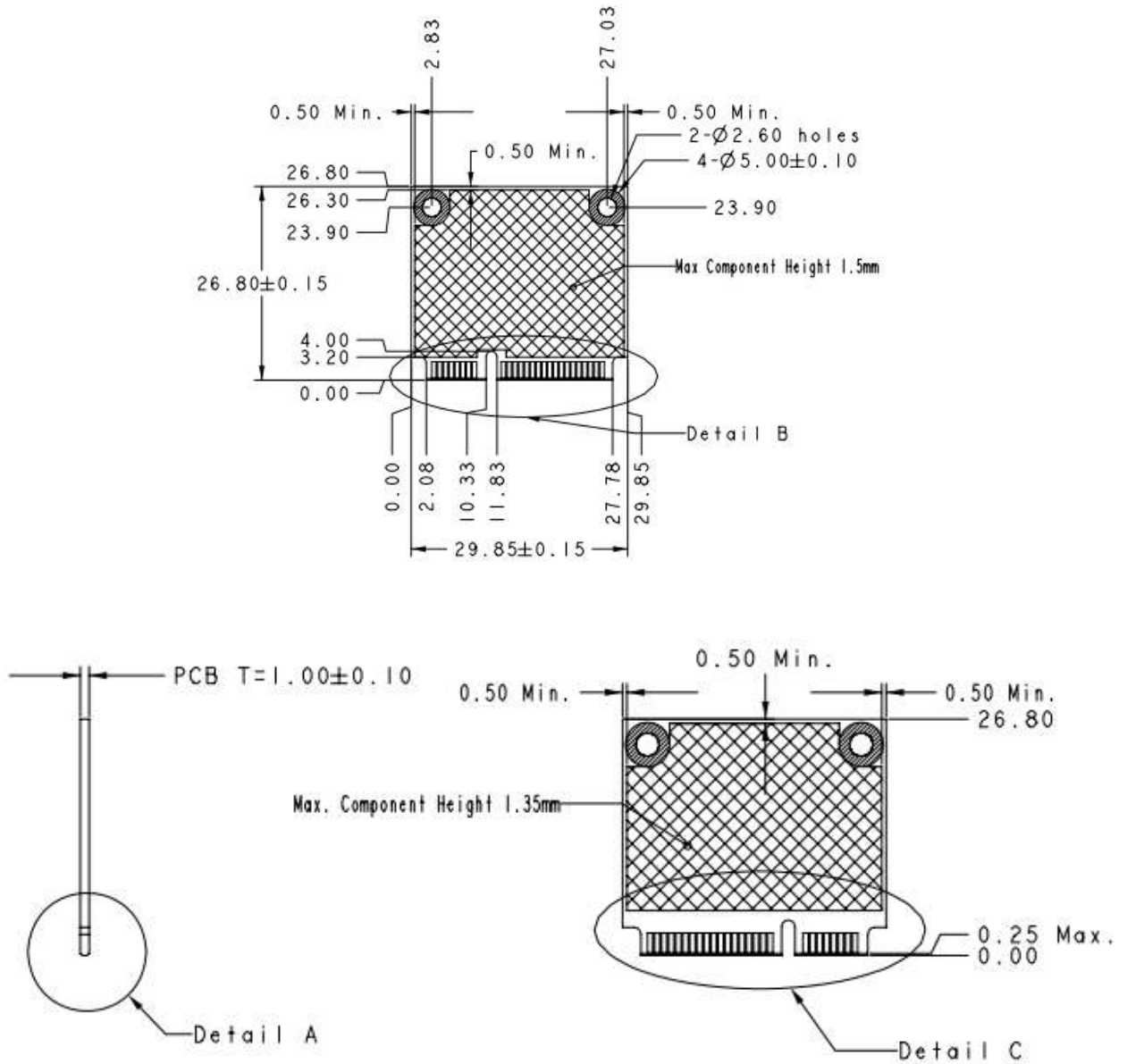

Unit: mm
 Tolerance: ± 0.2

mSATA Flash Drive
APSDMxxxGN1HN-XTM1X

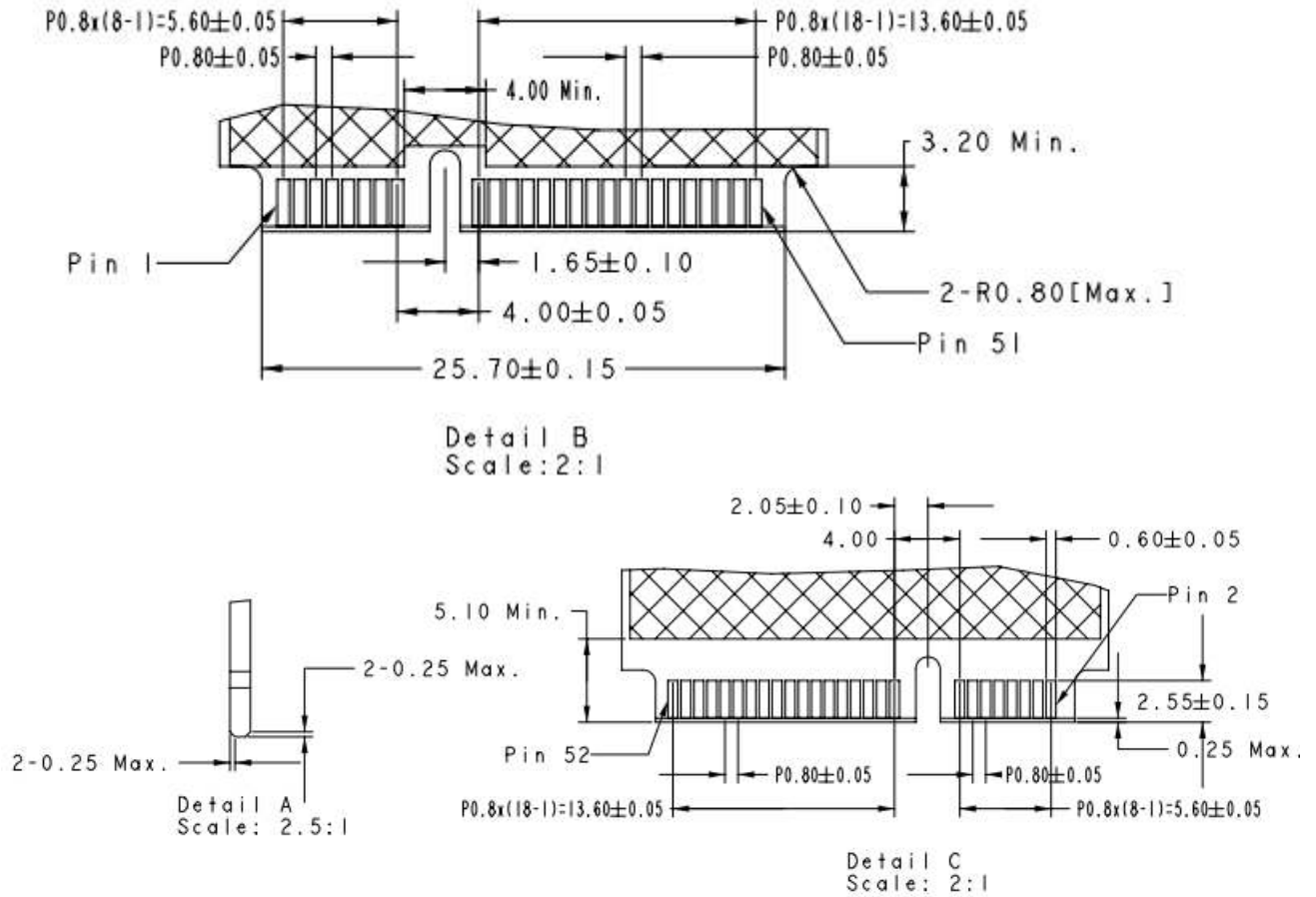

Notes :

1.  = Max Component Height
2.  = No Component
3.  = No Component / Signal Vias / Signal Copper / Printing
4. General Tolerance ± 0.1

Unit: mm
 Tolerance: ± 0.2

7. Product Ordering Information

7.1 Product Code Designation

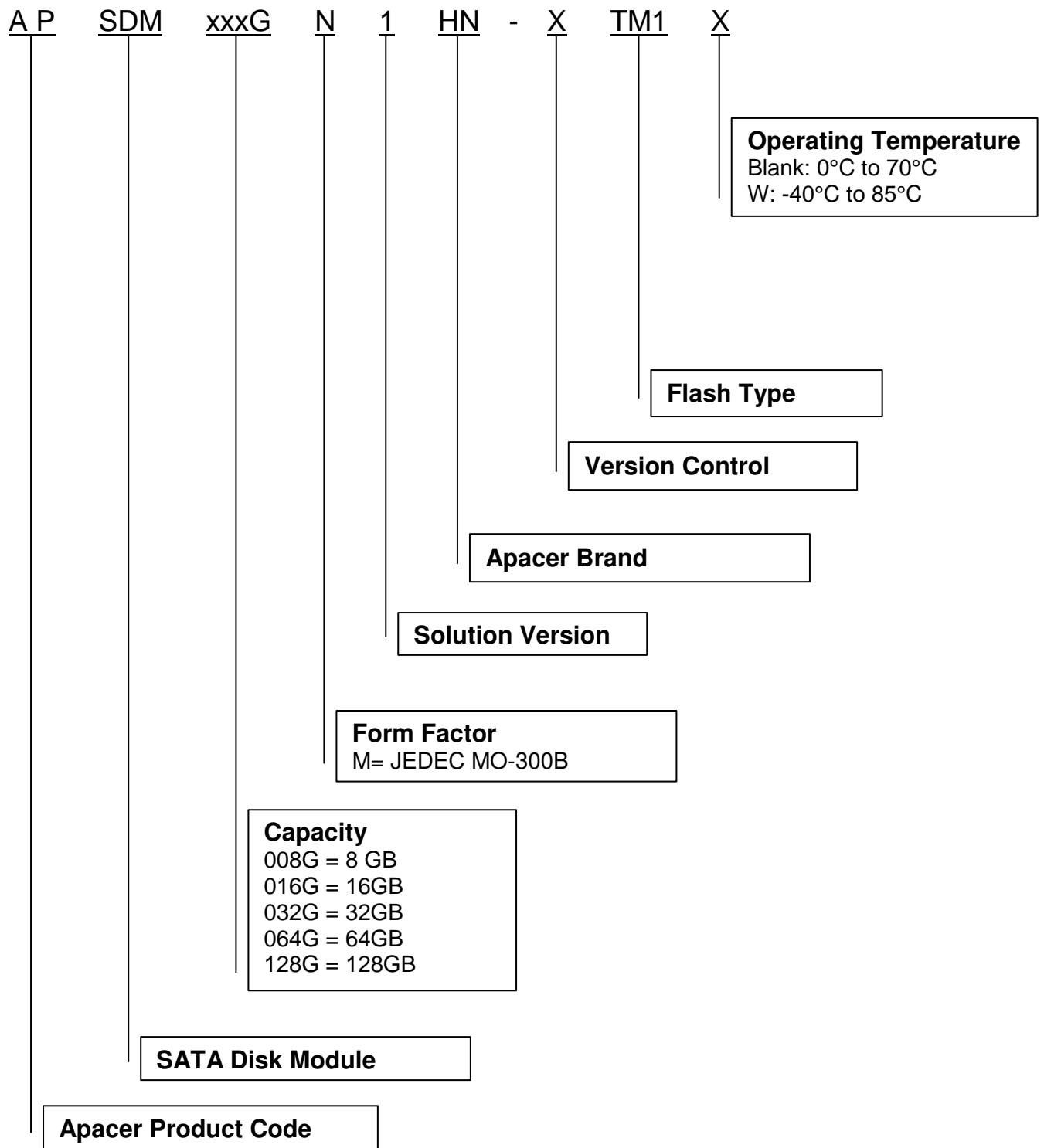

7.2 Valid Combinations

7.2.1 Operating Temperature (0°C ~ 70°C)

Capacity	No DEVSLP	DEVSLP
8GB	APSDM008GN1HN-GTM1	APSDM008GN1HN-HTM1
16GB	APSDM016GN1HN-GTM1	APSDM016GN1HN-HTM1
32GB	APSDM032GN1HN-GTM1	APSDM032GN1HN-HTM1
64GB	APSDM064GN1HN-GTM1	-
128GB	APSDM128GN1HN-GTM1	-

7.2.2 Operating Temperature (-40°C ~ 85°C)

Capacity	No DEVSLP	DEVSLP
8GB	APSDM008GN1HN-GTM1W	APSDM008GN1HN-HTM1W
16GB	APSDM016GN1HN-GTM1W	APSDM016GN1HN-HTM1W
32GB	APSDM032GN1HN-GTM1W	APSDM032GN1HN-HTM1W
64GB	APSDM064GN1HN-GTM1W	-
128GB	APSDM064GN1HN-GTM1W	-

Note: Valid combinations are those products in mass production or will be in mass production. Consult your Apacer sales representative to confirm availability of valid combinations and to determine availability of new combinations.

Revision History

Revision	Description	Date
1.0	Official release	10/30/2015
1.1	Remove DEVSLP support for 64GB and 128GB models	1/26/2016
1.2	Revised performance values for 64GB and 128GB models	3/25/2016

Global Presence

Taiwan (Headquarters)	Apacer Technology Inc. Apacer Technology Inc. 1F., No.32, Zhongcheng Rd., Tucheng Dist., New Taipei City 236, Taiwan R.O.C. Tel: 886-2-2267-8000 Fax: 886-2-2267-2261 amtsales@apacer.com
U.S.A.	Apacer Memory America, Inc. 46732 Lakeview Blvd., Fremont, CA 94538 Tel: 1-408-518-8699 Fax: 1-510-249-9568 sa@apacerus.com
Japan	Apacer Technology Corp. 5F, Matsura Bldg., Shiba, Minato-Ku Tokyo, 105-0014, Japan Tel: 81-3-5419-2668 Fax: 81-3-5419-0018 jpservices@apacer.com
Europe	Apacer Technology B.V. Science Park Eindhoven 5051 5692 EB Son, The Netherlands Tel: 31-40-267-0000 Fax: 31-40-267-0000#6199 sales@apacer.nl
China	Apacer Electronic (Shanghai) Co., Ltd Room D, 22/FL, No.2, Lane 600, JieyunPlaza, Tianshan RD, Shanghai, 200051, China Tel: 86-21-6228-9939 Fax: 86-21-6228-9936 sales@apacer.com.cn
India	Apacer Technologies Pvt Ltd, Unit No.201, "Brigade Corner", 7 th Block Jayanagar, Yediyur Circle, Bangalore – 560082, India Tel: 91-80-4152-9061 Fax: 91-80-4170-0215 sales_india@apacer.com