

## CS4207 HD Audio CODEC Development Platform

### Features

- ◆ Demonstrates Recommended Layout and Grounding Arrangements
- ◆ Analog I/O Use Standard 1/8" (3.5 mm) or 1/4" (6.35 mm) Jacks With Presence Detection
- ◆ Analog Inputs (Passive)
  - Single-ended and Differential MIC Inputs
  - Single-ended Stereo Line-level Input
- ◆ Analog Outputs (Passive)
  - Stereo Headphone Output with Test Loads
  - Single-ended and Differential Line Outputs
- ◆ Digital I/O
  - Optical S/PDIF I/O Jacks
  - Digital MIC Input Headers
  - HD Audio Bus Headers
  - CS4207 GPIO Header
- ◆ Powered by HDA Bus Connection to PC
  - Optionally Powered by Bench Supply or PC Peripheral Power Supply Cable (Molex)
- ◆ Configured by Hardware Jumpers
  - Power Supply Sources, Analog I/O Settings
- ◆ Current Sense Resistors for CS4207 Supplies

### Description

The CDB4207 is a flexible development platform designed for easy evaluation of the CS4207 HD Audio CODEC. Evaluation requires a PC with an HD Audio Bus connector and an analog or digital audio signal source for recording. Analog I/O is provided via 1/8" or 1/4" jacks. S/PDIF I/O is provided via optical connectors. Two identical HD Audio Bus headers are provided for connection to a PC.

The CDB4207 is configured via hardware jumper settings to set up the analog I/O circuitry and select a source for each CS4207 power supply rail. The analog inputs and outputs support several signal types for compatibility with a variety of signal sources and analyzers. The CS4207 can be powered from the HD Audio Bus header, a PC peripheral power supply cable, or external power supplies. Current sense resistors are included for easy power calculations during system development.

### ORDERING INFORMATION

CDB4207

Evaluation Board

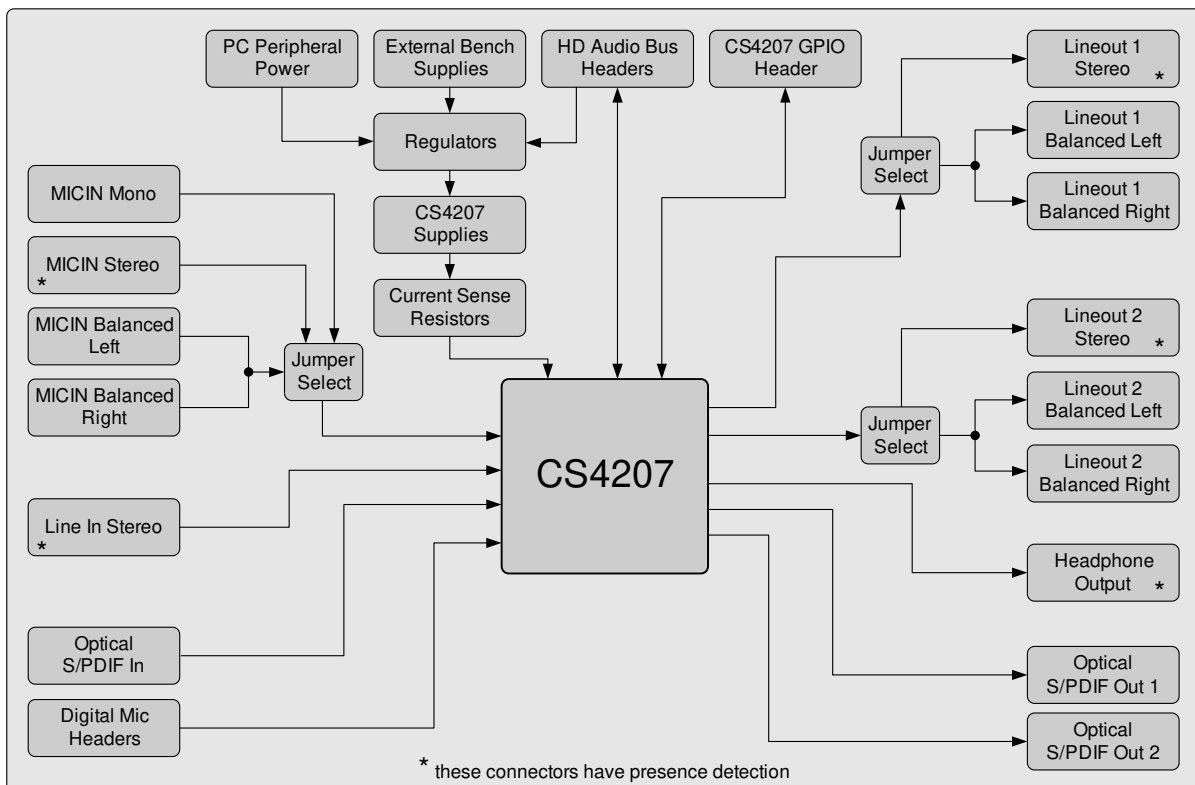

---

**TABLE OF CONTENTS**

<b>1. HARDWARE SYSTEM OVERVIEW .....</b>	<b>3</b>
1.1 CS4207 .....	3
1.2 Analog Inputs .....	3
1.3 Analog Outputs .....	3
1.4 Digital Microphone Inputs .....	4
1.5 S/PDIF I/O .....	4
1.6 GPIO Header .....	4
1.7 HD Audio Bus Headers .....	4
1.8 Power Supply Circuitry .....	5
1.9 Grounding and Power Supply Decoupling .....	5
<b>2. QUICK-START GUIDE .....</b>	<b>6</b>
<b>3. SYSTEM CONNECTIONS AND JUMPER SETTINGS .....</b>	<b>7</b>
<b>4. CDB4207 SCHEMATICS AND LAYOUT .....</b>	<b>11</b>
<b>5. ORDERING INFORMATION .....</b>	<b>21</b>
<b>6. REVISION HISTORY .....</b>	<b>21</b>

**LIST OF FIGURES**

Figure 1.CDB4207 Quick-Start Guide .....	6
Figure 2.CS4207 .....	11
Figure 3.Analog Inputs .....	12
Figure 4.Analog Outputs .....	13
Figure 5.Digital I/O .....	14
Figure 6.Power .....	15
Figure 7.CDB4207 Component Map .....	16
Figure 8.CDB4207 Top Layer .....	17
Figure 9.CDB4207 Inner Layer 1 - Ground .....	18
Figure 10.CDB4207 Inner Layer 2 - Power .....	19
Figure 11.CDB4207 Bottom Layer .....	20

**LIST OF TABLES**

Table 1. CDB4207 HD Audio Bus Header Pinout (J1 and J9) .....	5
Table 2. System Connections .....	7
Table 3. Jumper Settings .....	8
Table 4. Power Supply Indicator LEDs .....	10

## 1. HARDWARE SYSTEM OVERVIEW

The CDB4207 allows for easy and complete evaluation of the CS4207 HD Audio CODEC. Use of the CDB4207 requires only a PC with an available HD Audio Bus header. If desired the CDB4207 can be powered solely from the connected PC. The CDB4207 supports microphone and line-level analog input signals, line-level and headphone analog output signals, digital microphone input signals, and optical S/PDIF input and output signals.

### 1.1 CS4207

A description of the CS4207 HD Audio CODEC is included in the CS4207 datasheet. See [Figure 2 on page 11](#) for the CS4207 circuit schematic.

### 1.2 Analog Inputs

The analog input circuitry on the CDB4207 allows for all possible input configurations of the CS4207 to be tested. Microphone and line-level inputs are connected to the CS4207 using standard 1/8" (3.5 mm) or 1/4" (6.35 mm) jacks. All input configurations are passive and use the recommended DC-blocking capacitors and anti-aliasing filter capacitors.

The CDB4207 supports the following microphone input types: stereo fully-differential signals (J50 and J56), stereo single-ended/pseudo-differential signals (J42), and mono single-ended/pseudo-differential signals with phantom power (J28, into left channel of CS4207). Jumpers J46 and J52 connect the inverting microphone input pins of the CS4207 to either the negative signals of the differential input jacks or ground (for single-ended/pseudo-differential input types). Jumpers J33 and J37 configure the microphone input anti-aliasing capacitor for common-mode or differential filtering. Optionally, an external load may be applied to the MICBIAS pin of the CS4207 using J27. Current sensing for the MICBIAS supply is accomplished by unshunting J36 and measuring the voltage across R33. The CDB4207 supports stereo single-ended/pseudo-differential line-level input signals (J68).

The sleeve connection of the MIC and line input jacks is used for their respective signal's return path. The sleeve should thus be connected to the negative inputs of the CS4207's MIC and/or line input pins when configured in pseudo-differential mode. J43 and J60 are provided to connect the sleeve to board ground. The jumpers should be shunted when the MIC and/or line input source is floating and must use the board ground for its ground reference. To avoid ground loop issues, the jumpers should not be shunted if the MIC and/or line input source has its own external ground reference.

The microphone input jack presence detect signal is triggered by inserting a plug into either J42 or J28 or shunting J40. The line-level input jack presence detect signal is triggered by inserting a plug into J68 or shunting J61.

See [Figure 3 on page 12](#) for the analog input circuit schematic and [Section 3 on page 7](#) for the analog input connections and jumper selections. There is no on-board signal attenuation; see CS4207 datasheet for full-scale input amplitudes.

### 1.3 Analog Outputs

The analog output circuitry on the CDB4207 allows for full evaluation of the CS4207's analog outputs. Headphone and line-level outputs are connected to the CS4207 using standard 1/8" (3.5 mm) or 1/4" (6.35 mm) jacks. All output paths are passive. The headphone outputs use the recommended anti-peaking filters. The line-level outputs use the recommended DC-blocking capacitors (single-ended only) and low pass filters.

The headphone outputs are stereo single-ended/pseudo-differential signals available at J48. Optionally, a test load of 32  $\Omega$  or 16  $\Omega$  can be connected to each channel by using J47. The line-level outputs can be configured as stereo single-ended or fully-differential signals. For lineout 1, the single-ended or full-differential output option is selected using J59 and J51. The stereo single-ended output is available at J70. The

stereo full-differential outputs are available at J66 and J53. For lineout 2, the single-ended or full-differential output option is selected using J54 and J55. The stereo single-ended output is available at J69. The stereo full-differential outputs are available at J64 and J65.

The headphone output jack presence detect signal is triggered by inserting a plug into J48 or shunting J49. The lineout 1 jack presence detect signal is triggered by inserting a plug into J70 or shunting J67. Since the CS4207 can only support four jack detect signals on the SENSE\_A pin (MIC input, line input, headphone output, and lineout 1), the lineout 2 jack presence detect signal uses the CS4207's GPIO pins. The detect signal can be connected to GPIO2 or GPIO3 using J35. The signal is triggered by inserting a plug into J69.

See [Figure 4 on page 13](#) for the analog output circuit schematic and [Section 3 on page 7](#) for the analog output connections and jumper selections. There is no on-board signal attenuation; see CS4207 datasheet for full-scale output amplitudes.

## 1.4 Digital Microphone Inputs

The two stereo digital microphone inputs use 4-pin headers for connection to the CS4207. Digital MIC 1 uses headers J29 and J30 while digital MIC 2 uses headers J31 and J32. Pin 1 of each header is connected to DMIC\_SCL, the digital microphone clock signal from the CS4207. Pin 2 of each header is the data input signal to the CS4207. The data signals are multiplexed for each header pair (J29/J30 and J31/J32) to support stereo signals. Pin 3 of each header is fixed to a 3.3 V supply from an on-board regulator. Pin 4 of each header is fixed to ground.

See [Figure 5 on page 14](#) for the digital microphone circuit schematic and [Section 3 on page 7](#) for the digital microphone connections.

## 1.5 S/PDIF I/O

All S/PDIF I/O signals on the CDB4207 use optical connectors. The S/PDIF input signal to the CS4207 is supplied at J39. The S/PDIF output 1 signal from the CS4207 is available at J26. The S/PDIF output 2 signal from the CS4207 is available at J71. Since the S/PDIF output 2 signal from the CS4207 uses a multi-purpose pin, it can be disconnected from J71 by unshunting J16.

See [Figure 5 on page 14](#) for the S/PDIF I/O circuit schematic and [Section 3 on page 7](#) for the S/PDIF I/O connections and jumper selections.

## 1.6 GPIO Header

The CS4207's four GPIO pins are available at header J34. The GPIO signals are located in the middle column of the header. A 10 k $\Omega$  pull-down or pull-up resistor can be applied to each GPIO signal by shunting the middle column to column 1 or 3, respectively.

See [Figure 5 on page 14](#) for the GPIO header circuit schematic and [Section 3 on page 7](#) for the GPIO header connections and jumper selections.

## 1.7 HD Audio Bus Headers

The CDB4207 has duplicate HD Audio Bus headers for connection to a PC (J1 and J9). These headers allow for easy daisy chaining between CDB4207s for systems with multiple HD Audio CODECs. See [Table 1](#) for header pinout. The headers are keyed for a standard 16-pin ribbon cable. The header cable should only be connected or disconnected while the PC power is turned off. An alternate HD Audio Bus header for the digital I/O signals only is available at J20. The CS4207 will be connected to the serial digital input (SDI) line of the HD Audio Controller selected by header J21. See [Figure 5 on page 14](#) for the HD Audio Bus header circuit schematic and [Section 3 on page 7](#) for the HD Audio Bus header connections and jumper selections.

**Table 1. CDB4207 HD Audio Bus Header Pinout (J1 and J9)**

Pin	Signal
1	BCLK
2	GND
3	RST#
4	DVDD_IO (to J12 VL_HD header)
5	SYNC
6	GND
7	SDO
8	3.3V_DVDD_CORE (to J13 VL_IF header)
9	SDI0
10	+12V
11	SDI1
12	Key (no connection)
13	SDI2
14	3.3V_DUAL (to D12 indicator LED)
15	SDI3
16	GND

## 1.8 Power Supply Circuitry

The CDB4207 has several options for powering the CS4207 and auxiliary circuits. The main board power supply can be used to power the entire board through on-board regulators. The main board power supply can be provided by pin 10 of the HD Audio Bus header J1/J9, the PC peripheral power supply connector J14, or an external bench supply using J8 and J7. The three options are separated via Schottky diodes, thus the applied source with the largest voltage will be used. To use only this single power source, the CS4207 supply source selection headers (J10, J11, J12, J13, and J15) should be shunted in the 'REG' positions. Alternatively each CS4207 supply can be sourced directly from external bench supplies via banana jacks by shunting the 'EXT' position. In this case the main board power supply is still required to regulate a +3.3 V supply for the S/PDIF optical jacks, the digital microphone power, and the GPIO pull-up resistors.

For the VL\_HD supply 'REG' setting, J19 selects whether the supply is +3.3 V (unshunted) or +1.5 V (shunted). For the VD supply 'REG' setting, J18 selects whether the supply is +1.8 V (unshunted) or +1.5 V (shunted). For the VA supply 'REG' setting, J17 selects whether the supply is +5 V (unshunted), +4.7 V (1-2 shunted), +3.3 V (3-4 shunted), or +3.1V (5-6 shunted). In addition to the regulator and external options, the CS4207's VL\_IF and VL\_HD supplies can be powered directly from 3.3V\_DVDD\_CORE and DVDD\_IO on J1/J9 ('HDA'), respectively, and the VA\_HP supply can be powered directly from 3.3V\_DVDD\_CORE on J1/J9 ('3.3 V HDA') or +5 V on J14 ('5.0 V HDD').

Note that the VL\_HD supply voltage must match the chipset voltage used by the connected PC. This condition is guaranteed when the 'HDA' setting on J12 is selected instead of 'REG' or 'EXT'.

There are nine power supply indicator LEDs on the CDB4207. Each LED will be lit whenever the associated supply is turned on. See [Figure 6 on page 15](#) for the power supply circuit schematic and [Section 3 on page 7](#) for the power supply connections, jumper selections, and indicator LEDs.

## 1.9 Grounding and Power Supply Decoupling

As with any high-performance converter, the CS4207 requires careful attention to power supply and grounding arrangements to optimize performance. [Figure 2](#) details the connections to the CS4207 and [Figures 7, 8, 9, 10, and 11](#) show the component placement and the board layout. The decoupling capacitors are located as close as possible to the CS4207.

## 2. QUICK-START GUIDE

The following figure is a quick-start guide made for user convenience. The guide configures the board to be powered solely from the HD Audio Bus header. The user may choose to ignore steps 3, 4, or 6 through 9 depending on the desired I/O measurements required. See [Table 3](#) for board jumper settings and their factory default settings.

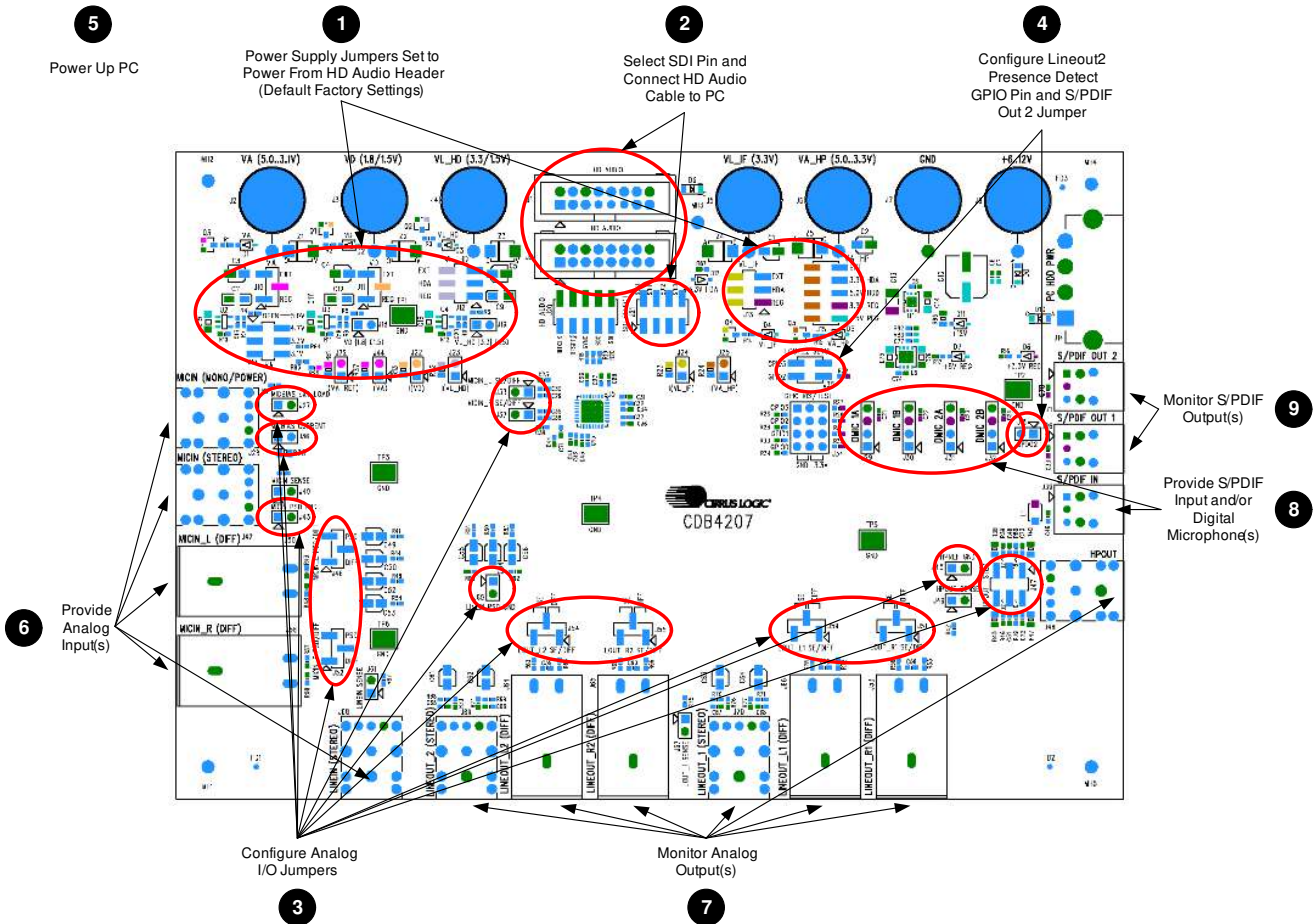

Figure 1. CDB4207 Quick-Start Guide

### 3. SYSTEM CONNECTIONS AND JUMPER SETTINGS

Table 2 below serves as a quick reference to all user interface elements, Table 3 outlines the various jumper settings on the board, and Table 4 lists the indicator LEDs.

**Table 2. System Connections**

Reference Designator	Silkscreen Label	Input / Output	Description
J50	MICIN_L (DIFF)	Input	1/4" jack, stereo differential microphone input, left channel
J56	MICIN_R (DIFF)	Input	1/4" jack, stereo differential microphone input, right channel
J42	MICIN (STEREO)	Input	1/8" jack, stereo single-ended microphone input with jack sense
J28	MICIN (MONO/POWER)	Input	1/8" jack, mono single-ended microphone input with phantom power, jack sense, and optional test load
J68	LINEIN (STEREO)	Input	1/8" jack, stereo single-ended line-level input with jack sense
J48	HPOUT	Output	1/8" jack, stereo single-ended headphone output with jack sense
J70	LINEOUT_1 (STEREO)	Output	1/8" jack, stereo single-ended line-level output with jack sense
J66	LINEOUT_L1 (DIFF)	Output	1/4" jack, stereo differential line-level output, left channel
J53	LINEOUT_R1 (DIFF)	Output	1/4" jack, stereo differential line-level output, right channel
J69	LINEOUT_2 (STEREO)	Output	1/8" jack, stereo single-ended line-level output with jack sense
J64	LINEOUT_L2 (DIFF)	Output	1/4" jack, stereo differential line-level output, left channel
J65	LINEOUT_R2 (DIFF)	Output	1/4" jack, stereo differential line-level output, right channel
J1	HD AUDIO	I/O	Connection to HD audio header on PC
J9	HD AUDIO	I/O	Duplicate of J1 (used for daisy chaining)
J20	HD AUDIO	I/O	HD audio bus digital I/O signal header
J34	GPIO VIS/TEST	I/O	GPIO visibility header with pull-up and pull-down resistors
J29	DMIC 1A	I/O	Header for digital microphone, shares data input with J30
J30	DMIC 1B	I/O	Header for digital microphone, shares data input with J29
J31	DMIC 2A	I/O	Header for digital microphone, shares data input with J32
J32	DMIC 2B	I/O	Header for digital microphone, shares data input with J31
J39	S/PDIF IN	Input	Optical connection for S/PDIF input signal
J26	S/PDIF OUT 1	Output	Optical connection for S/PDIF output 1 signal
J71	S/PDIF OUT 2	Output	Optical connection for S/PDIF output 2 signal
J14	PC HDD PWR	Input	Connector to power board from PC peripheral power supply cable
J8	+6...12V	Input	Banana jack to power board from bench power supply
J7	GND	Input	Banana jack for board power supply ground connection
J5	VL_IF (3.3V)	Input	Banana jack for CS4207 VL_IF supply
J4	VL_HD (3.3/1.5V)	Input	Banana jack for CS4207 VL_HD supply
J3	VD (1.8/1.5V)	Input	Banana jack for CS4207 VD supply
J2	VA (5.0...3.1V)	Input	Banana jack for CS4207 VA supply
J6	VA_HP (5.0...3.3V)	Input	Banana jack for CS4207 VA_HP supply

**Table 3. Jumper Settings (Sheet 1 of 2)**

Reference Designator	Silkscreen Label	Position	Function Selected
J25	I(VA_HP)	*shunted unshunted	When shunt is removed, the voltage can be measured across a fixed resistance to determine current.
J24	I(VL_IF)	shunted *unshunted	When shunt is removed, the voltage can be measured across a fixed resistance to determine current.
J23	I(VL_HD)	shunted *unshunted	When shunt is removed, the voltage can be measured across a fixed resistance to determine current.
J22	I(VD)	shunted *unshunted	When shunt is removed, the voltage can be measured across a fixed resistance to determine current.
J44	I(VA)	*shunted unshunted	When shunt is removed, the voltage can be measured across a fixed resistance to determine current.
J72	I(VA_REF)	*shunted unshunted	When shunt is removed, the voltage can be measured across a fixed resistance to determine current.
J46	MICIN_L PSD/DIFF	1-2 *2-3	Differential - connects MICIN_L negative signal to CS4207 Pseudo-differential - connects MICIN jack ground to CS4207
J52	MICIN_R PSD/DIFF	1-2 *2-3	Differential - connects MICIN_R negative signal to CS4207 Pseudo-differential - connects MICIN jack ground to CS4207
J33	MICIN_L SE/DIFF	*shunted unshunted	Single-ended - MICIN_L filter common mode Differential - MICIN_L filter differential mode
J37	MICIN_R SE/DIFF	*shunted unshunted	Single-ended - MICIN_R filter common mode Differential - MICIN_R filter differential mode
J43	MICIN PSD GND	*shunted unshunted	MICIN jack ground shorted to board ground MICIN jack ground floating
J27	MICBIAS EXT LOAD	*open load resistor pin 1-2	No external load on MICBIAS pin External load added to MICBIAS pin
J36	MICBIAS CURRENT	shunted *unshunted	When shunt is removed, the voltage can be measured across a fixed resistance to determine current.
J60	LINEIN PSD GND	*shunted unshunted	LINEIN jack ground shorted to board ground LINEIN jack ground floating
J45	HPREF GND	*shunted unshunted	HPREF shorted to board ground HPREF floating
J59	LOUT_L1 SE/DIFF	1-2 *2-3	Differential - LOUT_L1+ connected to J66 Single-ended - LOUT_L1+ connected to J70
J51	LOUT_R1 SE/DIFF	1-2 *2-3	Differential - LOUT_R1+ connected to J53 Single-ended - LOUT_R1+ connected to J70
J54	LOUT_L2 SE/DIFF	1-2 *2-3	Differential - LOUT_L2+ connected to J64 Single-ended - LOUT_L2+ connected to J69
J55	LOUT_R2 SE/DIFF	1-2 *2-3	Differential - LOUT_R2+ connected to J65 Single-ended - LOUT_R2+ connected to J69
J21	SDI SELECT	*1-2 3-4 5-6 7-8	CS4207 SDI connects to SDI0 on J1 and J9 CS4207 SDI connects to SDI1 on J1 and J9 CS4207 SDI connects to SDI2 on J1 and J9 CS4207 SDI connects to SDI3 on J1 and J9
J67	LOUT_1 SENSE	shunted *unshunted	LINEOUT 1 jack presence detection override LINEOUT 1 jack presence detection normal
J61	LINEIN SENSE	shunted *unshunted	LINEIN jack presence detection override LINEIN jack presence detection normal



**Table 3. Jumper Settings (Sheet 2 of 2)**

Reference Designator	Silkscreen Label	Position	Function Selected
J40	MICIN SENSE	shunted *unshunted	MICIN jack presence detection override MICIN jack presence detection normal
J49	HPOUT SENSE	shunted *unshunted	HPOUT jack presence detection override HPOUT jack presence detection normal
J35	LOUT_2 SENSE	*unshunted 1-2 3-4	LINEOUT 2 jack presence detection signal unused LINEOUT 2 jack presence detection connected to GPIO2 LINEOUT 2 jack presence detection connected to GPIO3
J47	HPOUT TSTLD	*unshunted 1-3, 2-4 3-5, 4-6	no load on HPOUT_L and HPOUT_R 16 $\Omega$ load on HPOUT_L and HPOUT_R 32 $\Omega$ load on HPOUT_L and HPOUT_R
J16	SPDO2	*shunted unshunted	GPIO1/DMIC_SDA2/SPDIF_OUT2 connected to J71 GPIO1/DMIC_SDA2/SPDIF_OUT2 disconnected from J71
J13	VL_IF	1-2 *3-4 5-6	VL_IF = 3.3 V from on-board regulator VL_IF = 3.3 V from pin 8 of J1 or J9 VL_IF = J5 external voltage supply
J12	VL_HD	1-2 *3-4 5-6	VL_HD = 3.3 V or 1.5 V from on-board regulator (see J19) VL_HD = 3.3 V from pin 4 of J1 or J9 VL_HD = J4 external voltage supply
J19	VL_HD  3.3  [1.5]	shunted *unshunted	VL_HD regulator output = 1.5 V VL_HD regulator output = 3.3 V
J11	VD	*1-2 2-3	VD = 1.8 V or 1.5 V from on-board regulator (see J18) VD = J3 external voltage supply
J18	VD  1.8  [1.5]	shunted *unshunted	VD regulator output = 1.5 V VD regulator output = 1.8 V
J10	VA	*1-2 2-3	VA = on-board regulator (see J17) VA = J2 external voltage supply
J17	VA	no shunt 1-2 *3-4 5-6	VA regulator output = 5.0 V VA regulator output = 4.7 V VA regulator output = 3.3 V VA regulator output = 3.1 V
J15	VA_HP	1-2 *3-4 5-6 7-8 9-10	VA_HP = 5.0 V from on-board regulator VA_HP = 3.3 V from on-board regulator VA_HP = 5.0 V from pin 4 of J14 VA_HP = 3.3 V from pin 8 of J1 or J9 VA_HP = J6 external voltage supply

**Note:** All settings denoted by an asterisk (\*) are the Default Factory Settings.

Table 4. Power Supply Indicator LEDs

Reference Designator	Silkscreen Label	Description
D1	VA	CS4207 VA supply is powered on when LED is lit
D2	VD	CS4207 VD supply is powered on when LED is lit
D3	VL_HD	CS4207 VL_HD supply is powered on when LED is lit
D4	VL_IF	CS4207 VL_IF supply is powered on when LED is lit
D5	VA_HP	CS4207 VA_HP supply is powered on when LED is lit
D6	+3.3V REG	+5V to +3.3V regulator output supply is powered on when LED is lit
D7	+5V REG	+12V to +5V regulator output supply is powered on when LED is lit
D11	+12V	+12V supply from J8, J14, J1 or J9 is powered on when LED is lit
D12	+3.3V HDA	+3.3V supply from J1 or J9 is powered on when LED is lit

## 4. CDB4207 SCHEMATICS AND LAYOUT

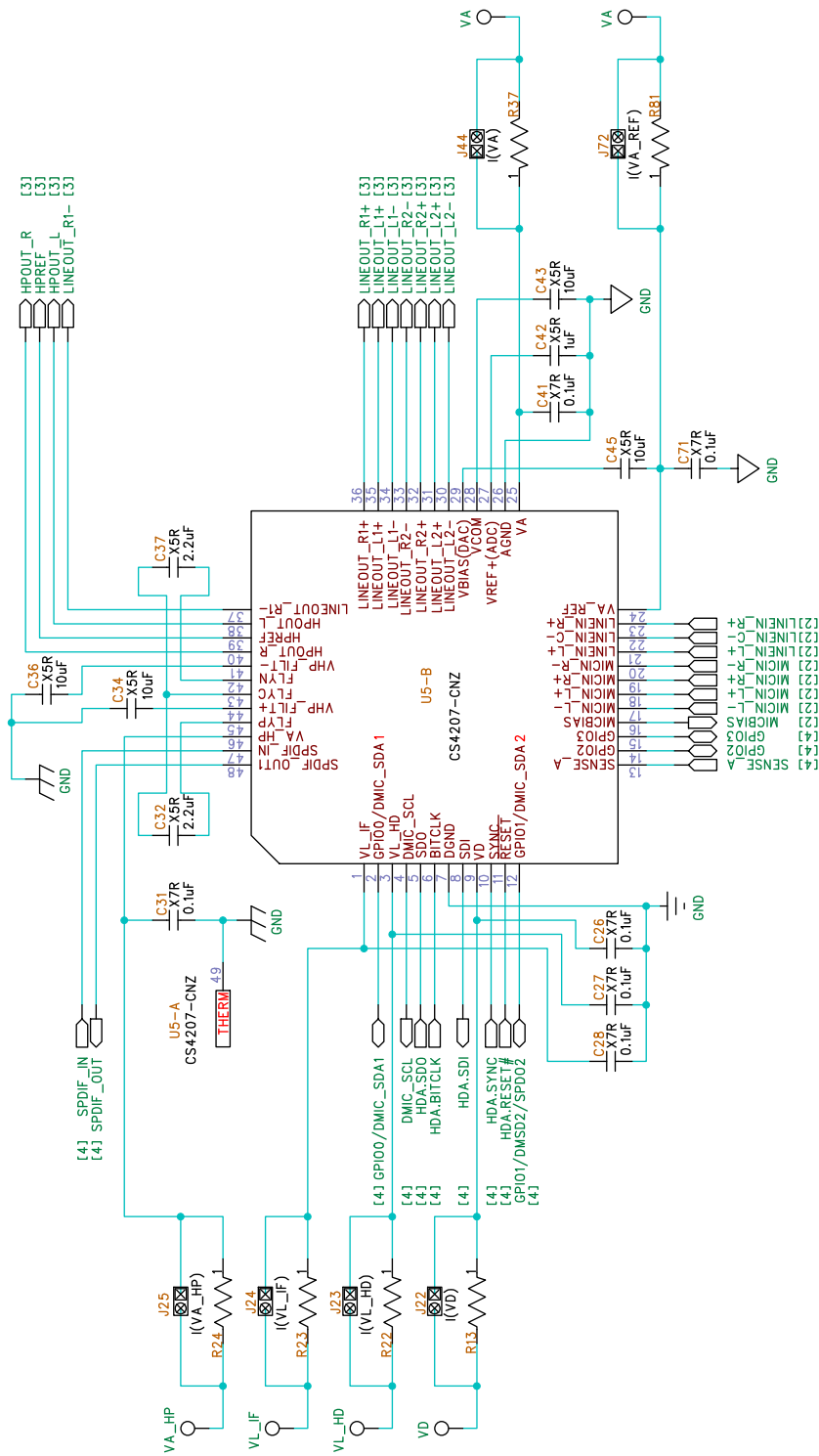

Figure 2. CS4207

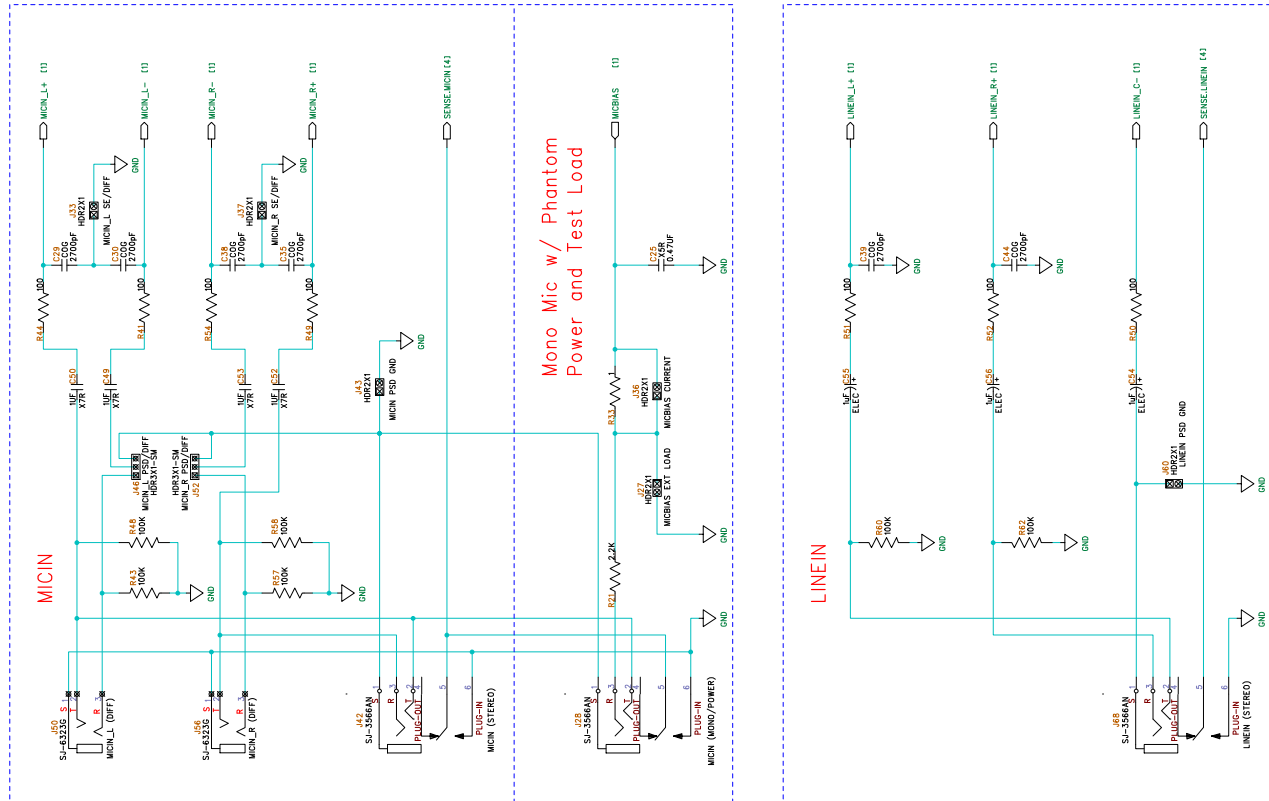

Figure 3. Analog Inputs

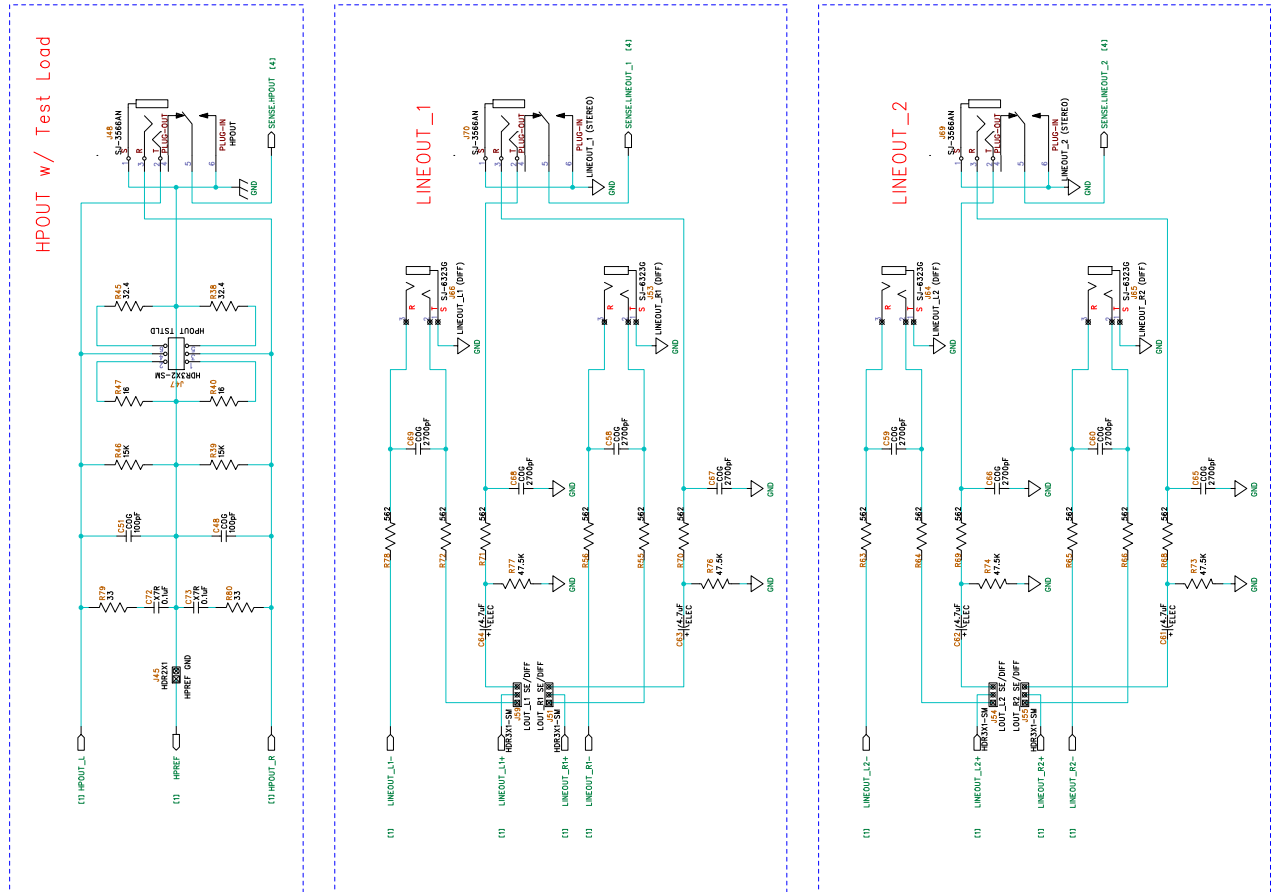

Figure 4. Analog Outputs



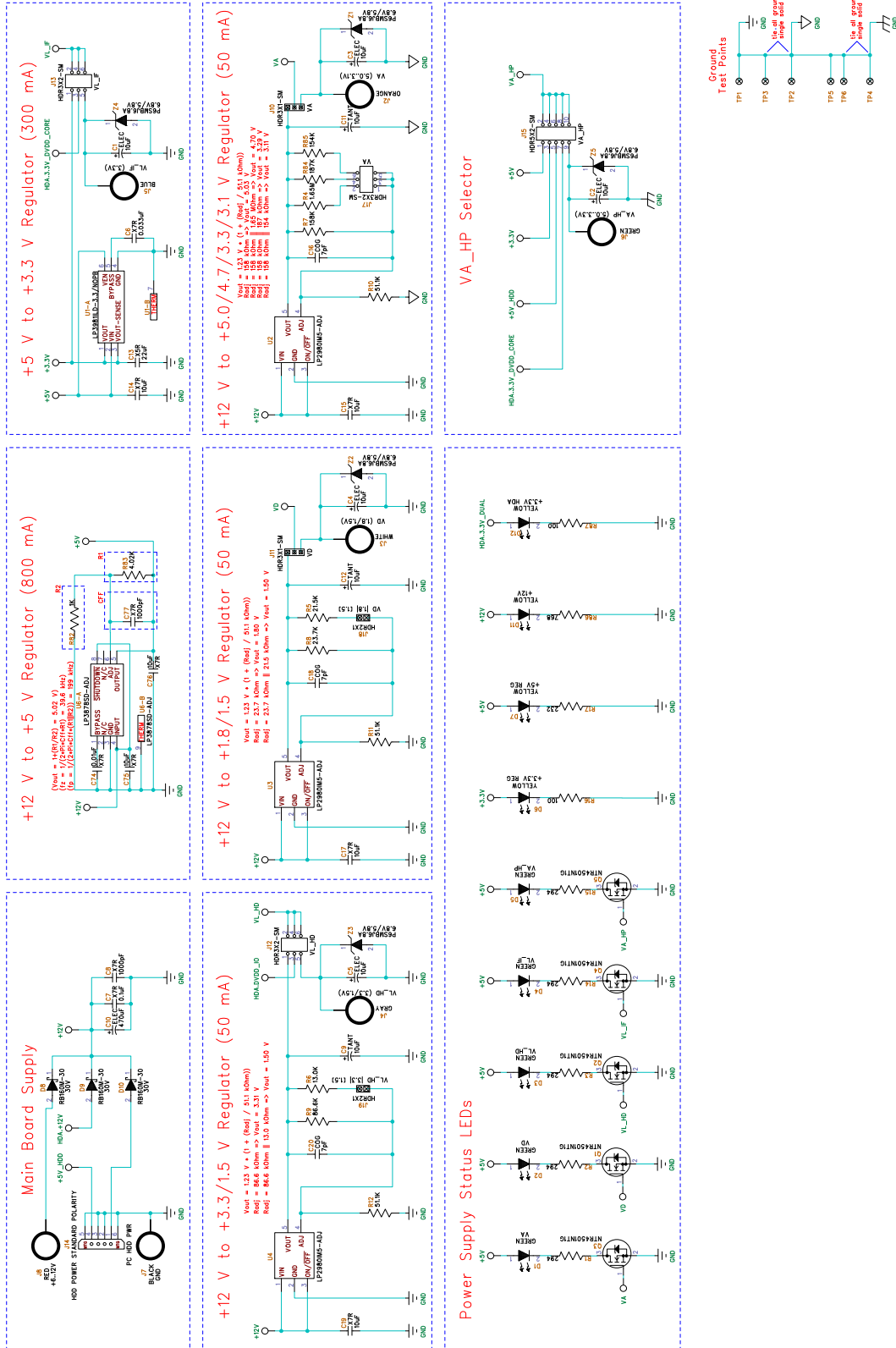

Figure 6. Power

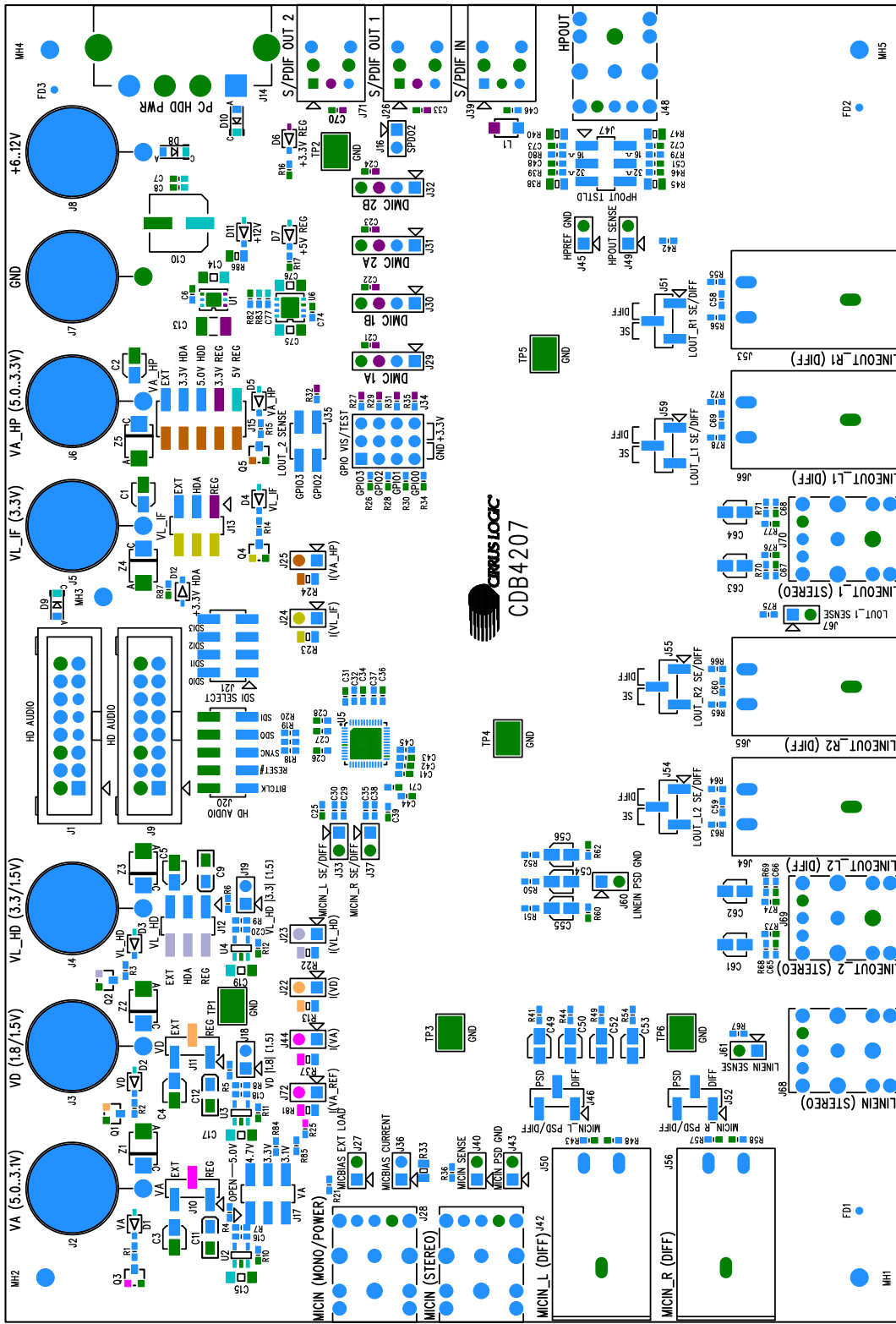

Figure 7. CDB4207 Component Map



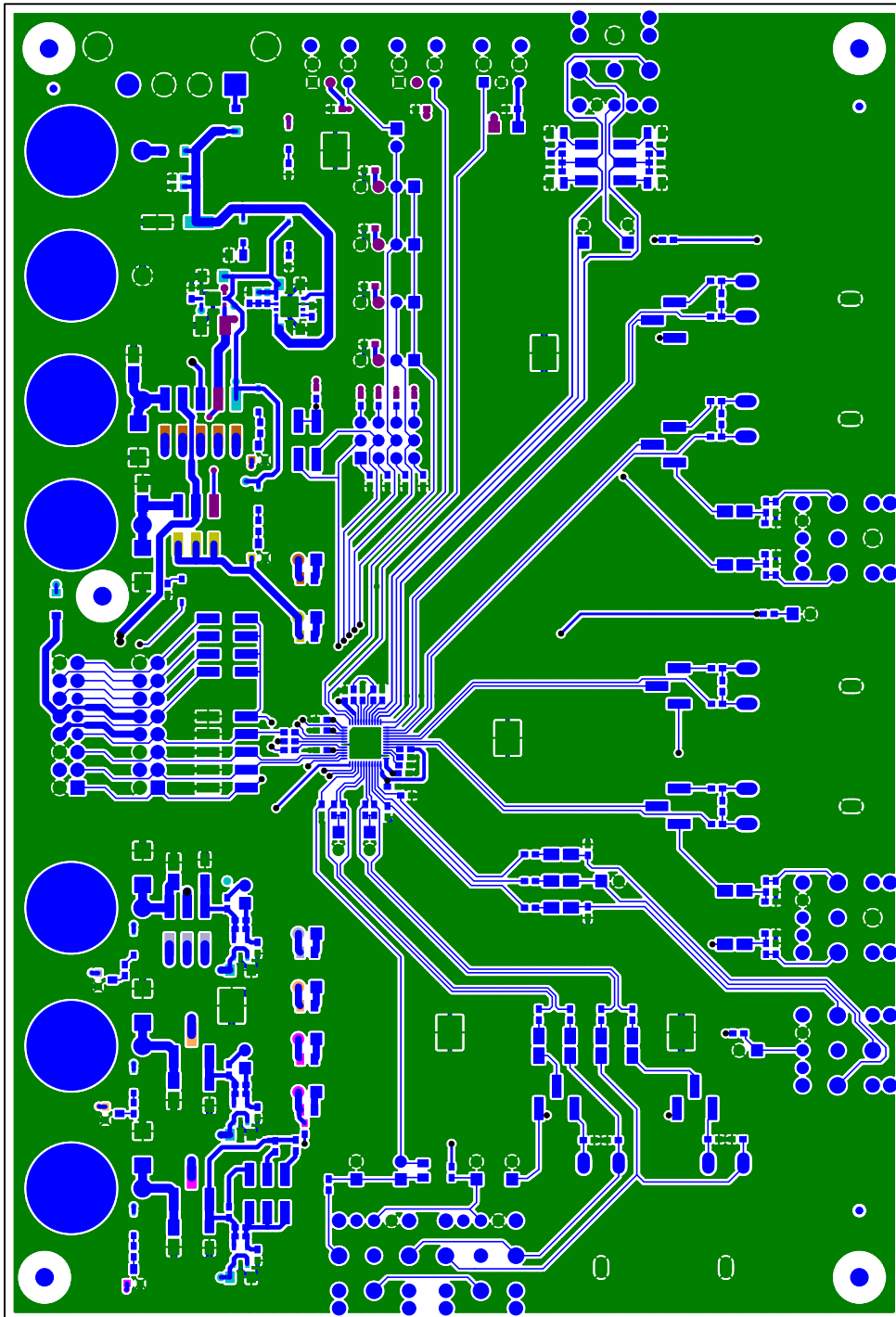

Figure 8. CDB4207 Top Layer

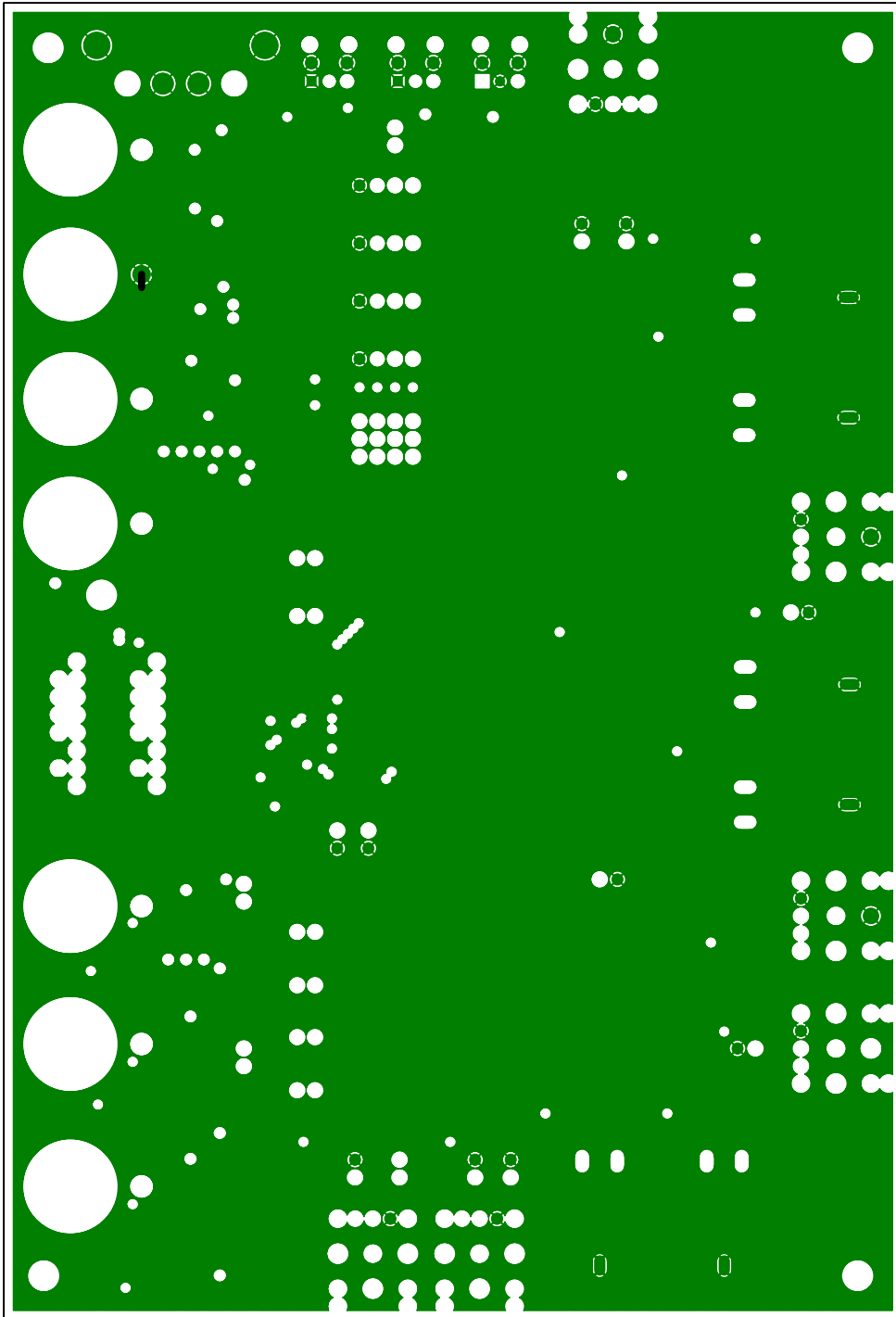

Figure 9. CDB4207 Inner Layer 1 - Ground

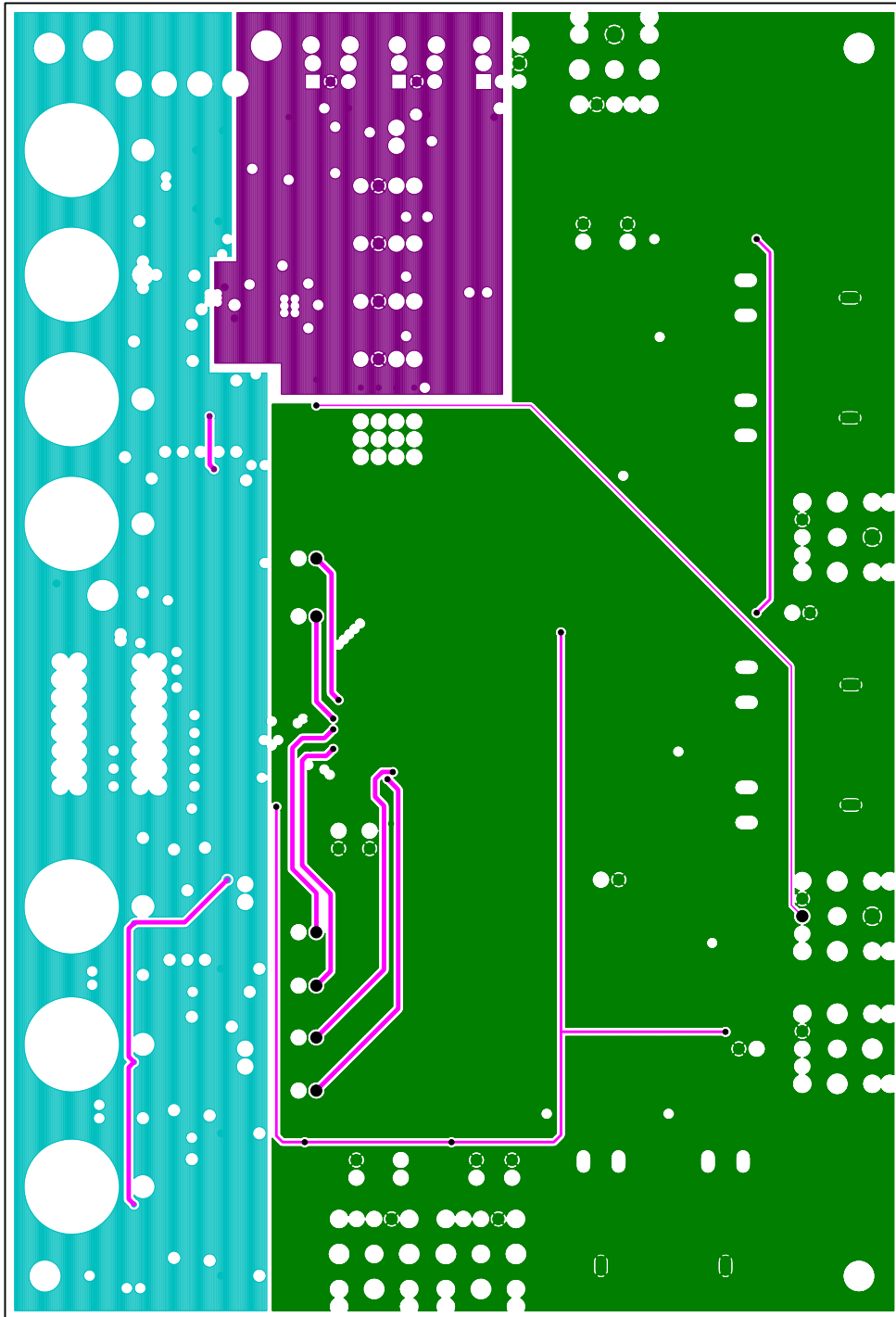

Figure 10. CDB4207 Inner Layer 2 - Power

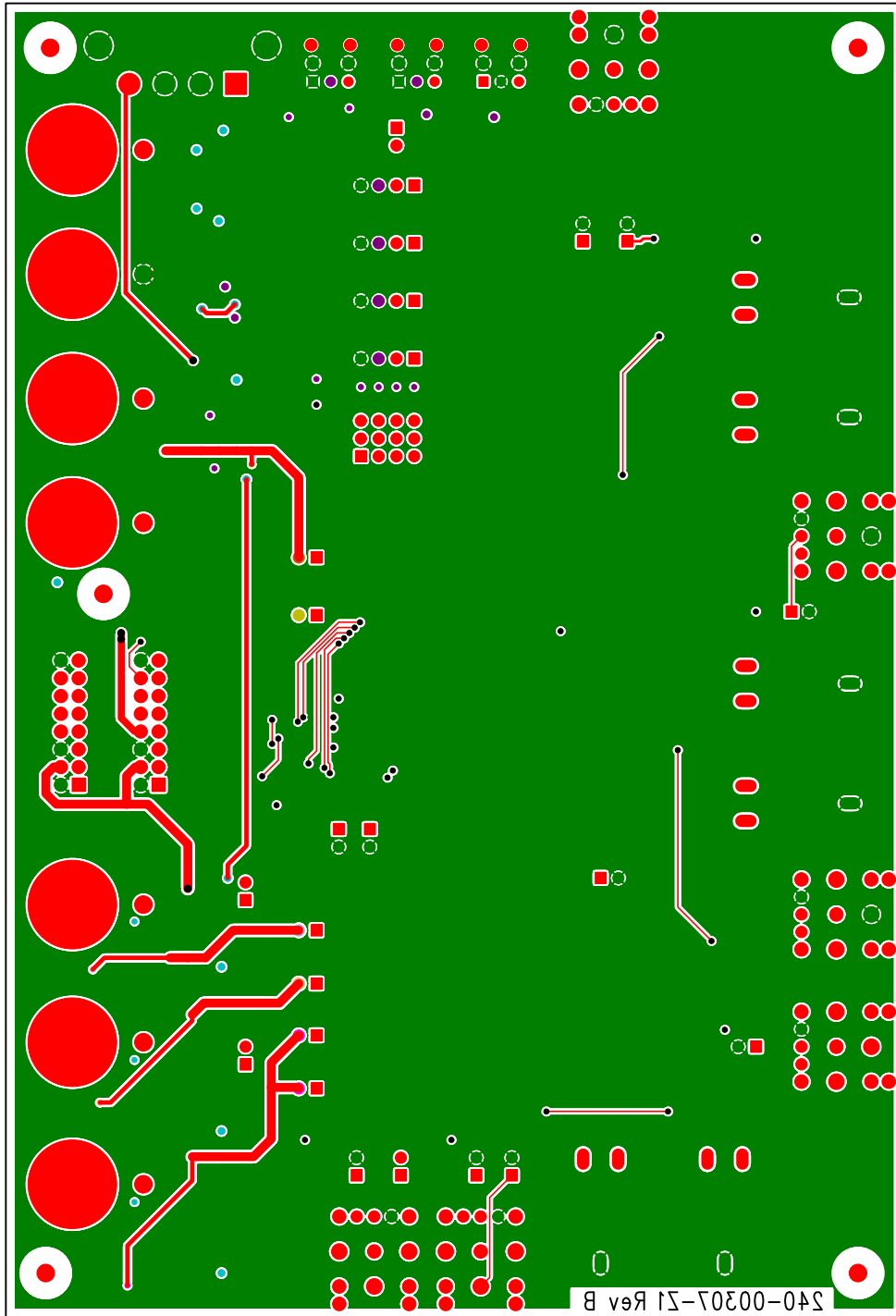

Figure 11. CDB4207 Bottom Layer

---

**5. ORDERING INFORMATION**

Product	Description	Included Hardware	Order #
CDB4207	CS4207 Evaluation Board	1 x CDB4207 1 x 16-pin HD Audio cable	CDB4207

**6. REVISION HISTORY**

Release	Date	Changes
DB1	NOV 2009	Initial Release

---

## Contacting Cirrus Logic Support

For all product questions and inquiries, contact a Cirrus Logic Sales Representative.  
To find the one nearest you, go to [www.cirrus.com](http://www.cirrus.com).

---

### IMPORTANT NOTICE

Cirrus Logic, Inc. and its subsidiaries ("Cirrus") believe that the information contained in this document is accurate and reliable. However, the information is subject to change without notice and is provided "AS IS" without warranty of any kind (express or implied). Customers are advised to obtain the latest version of relevant information to verify, before placing orders, that information being relied on is current and complete. All products are sold subject to the terms and conditions of sale supplied at the time of order acknowledgment, including those pertaining to warranty, indemnification, and limitation of liability. No responsibility is assumed by Cirrus for the use of this information, including use of this information as the basis for manufacture or sale of any items, or for infringement of patents or other rights of third parties. This document is the property of Cirrus and by furnishing this information, Cirrus grants no license, express or implied under any patents, mask work rights, copyrights, trademarks, trade secrets or other intellectual property rights. Cirrus owns the copyrights associated with the information contained herein and gives consent for copies to be made of the information only for use within your organization with respect to Cirrus integrated circuits or other products of Cirrus. This consent does not extend to other copying such as copying for general distribution, advertising or promotional purposes, or for creating any work for resale.

CERTAIN APPLICATIONS USING SEMICONDUCTOR PRODUCTS MAY INVOLVE POTENTIAL RISKS OF DEATH, PERSONAL INJURY, OR SEVERE PROPERTY OR ENVIRONMENTAL DAMAGE ("CRITICAL APPLICATIONS"). CIRRUS PRODUCTS ARE NOT DESIGNED, AUTHORIZED OR WARRANTED FOR USE IN PRODUCTS SURGICALLY IMPLANTED INTO THE BODY, AUTOMOTIVE SAFETY OR SECURITY DEVICES, LIFE SUPPORT PRODUCTS OR OTHER CRITICAL APPLICATIONS. INCLUSION OF CIRRUS PRODUCTS IN SUCH APPLICATIONS IS UNDERSTOOD TO BE FULLY AT THE CUSTOMER'S RISK AND CIRRUS DISCLAIMS AND MAKES NO WARRANTY, EXPRESS, STATUTORY OR IMPLIED, INCLUDING THE IMPLIED WARRANTIES OF MERCHANTABILITY AND FITNESS FOR PARTICULAR PURPOSE, WITH REGARD TO ANY CIRRUS PRODUCT THAT IS USED IN SUCH A MANNER. IF THE CUSTOMER OR CUSTOMER'S CUSTOMER USES OR PERMITS THE USE OF CIRRUS PRODUCTS IN CRITICAL APPLICATIONS, CUSTOMER AGREES, BY SUCH USE, TO FULLY INDEMNIFY CIRRUS, ITS OFFICERS, DIRECTORS, EMPLOYEES, DISTRIBUTORS AND OTHER AGENTS FROM ANY AND ALL LIABILITY, INCLUDING ATTORNEYS' FEES AND COSTS, THAT MAY RESULT FROM OR ARISE IN CONNECTION WITH THESE USES.

Cirrus Logic, Cirrus, and the Cirrus Logic logo designs are trademarks of Cirrus Logic, Inc. All other brand and product names in this document may be trademarks or service marks of their respective owners.