

## Lightweight, 5.4 dBd, Omnidirectional Base Station and Marine Antenna for the 900 MHz Band

### DESCRIPTION

- CXL 900-6LW/... is a 6 dBd, vertically polarized, omnidirectional base station and marine antenna, covering the 900 MHz band in two models.
- Provided with the sturdy "LW" mast mount – a lightweight, multipurpose, epoxy-coated mounting bracket made of non-corrosive aluminium.
- The accompanying U-bolts and fittings are made of stainless steel.
- To be mounted on vertical or horizontal mast tubes, 16 to 54 mm in outer diameter.
- The cable can be led either on the outside or along the inside of the mast tube.
- Large bandwidth with respect to both VSWR and gain.
- Highly suitable for duplex operation with large spacing between the Tx and Rx frequencies.
- The carefully designed radiating element is sealed in a high-quality, glass fibre tube with low wind-load, ensuring undisturbed performance in all climates.
- To substantially reduce noise caused by atmospherical discharges, all metal parts in the antenna are DC-grounded. Consequently, the antenna shows a DC-short across the coaxial cable.
- The CXL 900-6LW/... is a vibration-proof, lightweight, slim-line, corrosion resistant, modern style base station and marine antenna.



### SPECIFICATIONS

Electrical	
Model	CXL 900-6LW/...
Frequency	Models within 824 - 960 MHz
Antenna Type	Collinear, broad-band
Max. Input Power	150 W
Polarisation	Vertical
Pattern Type	Omnidirectional
3 dB Beamwidth, E-Plane	16 °
3 dB Beamwidth, H-Plane	Omnidirectional
Impedance	50 Ω
Gain	5.4 dBd (7.6 dBi)
VSWR	< 1.5:1
Bandwidth	70 - 90 MHz
Antistatic Protection	All metal parts DC-grounded (Connector shows a DC-short)
HCM Code(s)	HCM000ND00, 008DE22

Mechanical	
Connection(s)	N(f)
Materials	Shroud: Polyurethane-coated glass fibre Mounting bracket: Seawater resistant aluminium, epoxy-coated Clamps: Stainless steel
Colour	White (RAL 9003)
Wind Area	0.030 sq. m / 0.32 sq. ft
Wind Load	43 N (160km/h)
Dia. At Top End	23 mm / 0.91 in.
Dia. At Bottom End	23 mm / 0.91 in.
Height	1260 - 1310 mm / 49.61 - 51.57 in.
Weight	Approx. 1.0 kg / 3.09 lb.
Mounting	On 16 - 54 mm / 0.63 - 2.13 in. dia. mast tube
Environmental	
Operating temperature range	-30°C to +70°C
Survival Wind Speed	200 km/h
Ingress Protection	IP66

### ORDERING

Model	Product No.	Frequency
CXL 900-6LW/l	100000139	824 - 894 MHz
CXL 900-6LW/m	100000138	870 - 950 MHz
CXL 900-6LW/h	100000137	890 - 960 MHz

TYPICAL VSWR CURVES

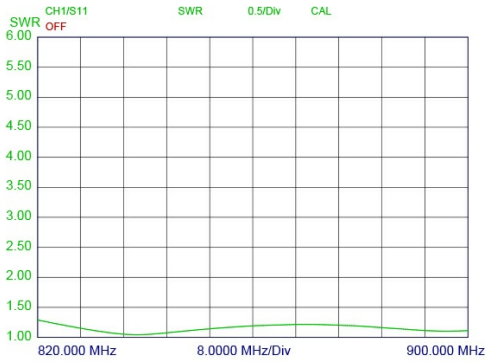

TYPICAL RADIATION PATTERN (E-PLANE)

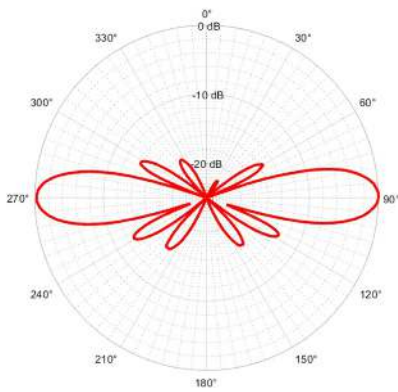

TYPICAL RADIATION PATTERN (H-PLANE)

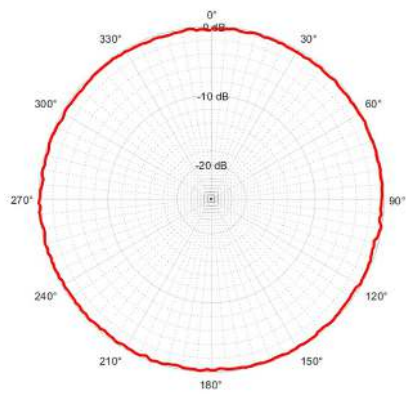

MULTI-PURPOSE MOUNTING BRACKET

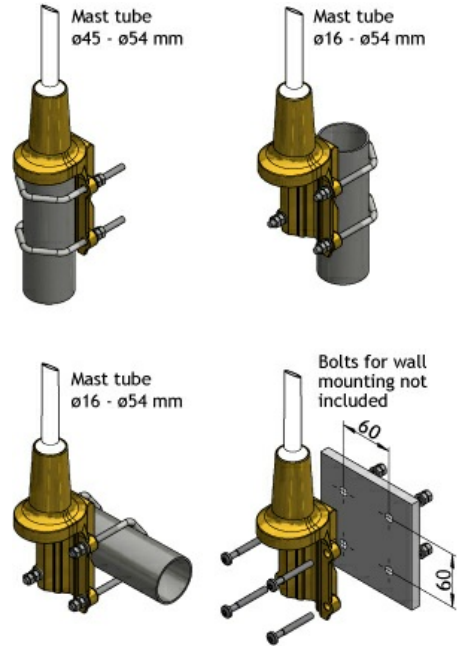

PLEASE NOTE

The antenna is delivered with a DC-connection between the antenna element and the mounting bracket.