

THIS DRAWING IS UNPUBLISHED. RELEASED FOR PUBLICATION 20  
 © COPYRIGHT 20 BY TYCO ELECTRONICS CORPORATION. ALL RIGHTS RESERVED.

LOC	DIST	REVISIONS					
J	-	P	LTR	DESCRIPTION	DATE	DWN	APVD
			O	RELEASED FJC0-0193-04	13-Jul-04	J.K	S.Y
			A	ECR-15-002973	25FEB2015	JK	JK

-1: AS SHOWN (本図)

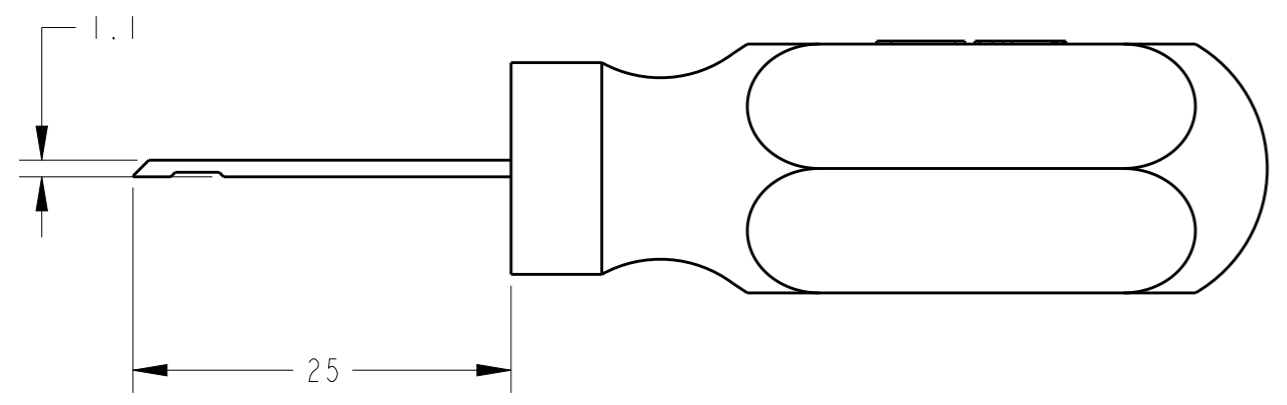
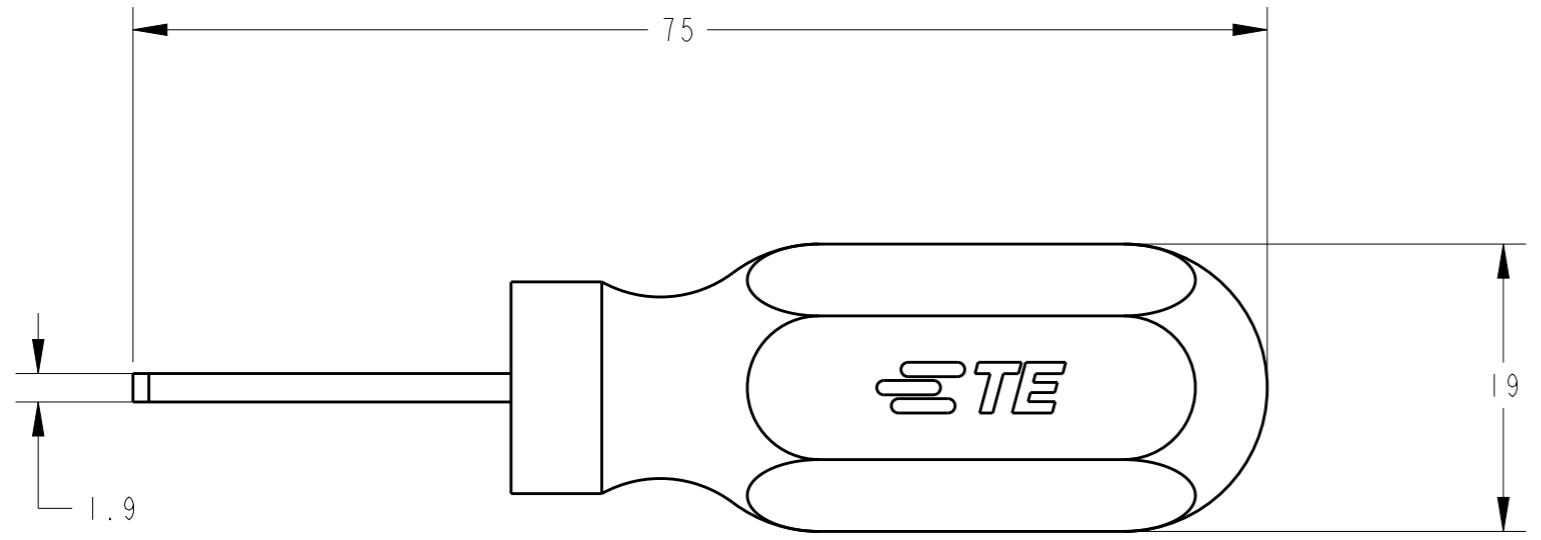

- 1 APPLICABLE PRODUCTS 通用製品
  - TERMINAL (STRIP) : 1717148-1
  - : 1318329-1
  - : 1612776-1
  - : 1318332-1
  - : 1612775-1
  - PLUG HOUSING : 1717138-4
  - : 1717138-5
  - : 1717138-6
- 2 INSTRUCTION SHEET NO: 411-78158  
取扱説明書番号

<small>THIS DRAWING IS A CONTROLLED DOCUMENT FOR TYCO ELECTRONICS CORPORATION          IT IS SUBJECT TO CHANGE AND THE CONTROLLING ENGINEERING ORGANIZATION          SHOULD BE CONTACTED FOR THE LATEST REVISION.</small>		DWN J. KOGA 13-Jul-04 CHK J. KOGA 13-Jul-04 APVD S. YABE 13-Jul-04		TE Connectivity Kawasaki, Japan	
DIMENSIONS: mm		TOLERANCES UNLESS OTHERWISE SPECIFIED: 0 PLC ±- 1 PLC ±- 2 PLC ±- 3 PLC ±- 4 PLC ±- ANGLES ±-		NAME EXT-TOOL, 025/040 CLEAN BODY CONN 025/040	
MATERIAL		FINISH		PRODUCT SPEC - APPLICATION SPEC - WEIGHT -	
Customer Drawing				SIZE A3 CAGE CODE 00779 DRAWING NO. C-1729919	RESTRICTED TO -
				SCALE 2:1	SHEET 1 OF 1 REV A