

FUSB251GEVB

FUSB251 - Type-C CC and SBU Protection IC Evaluation Board User's Manual



ON Semiconductor®

www.onsemi.com

APPLICATIONS BOARD DIAGRAM

EVAL BOARD USER'S MANUAL

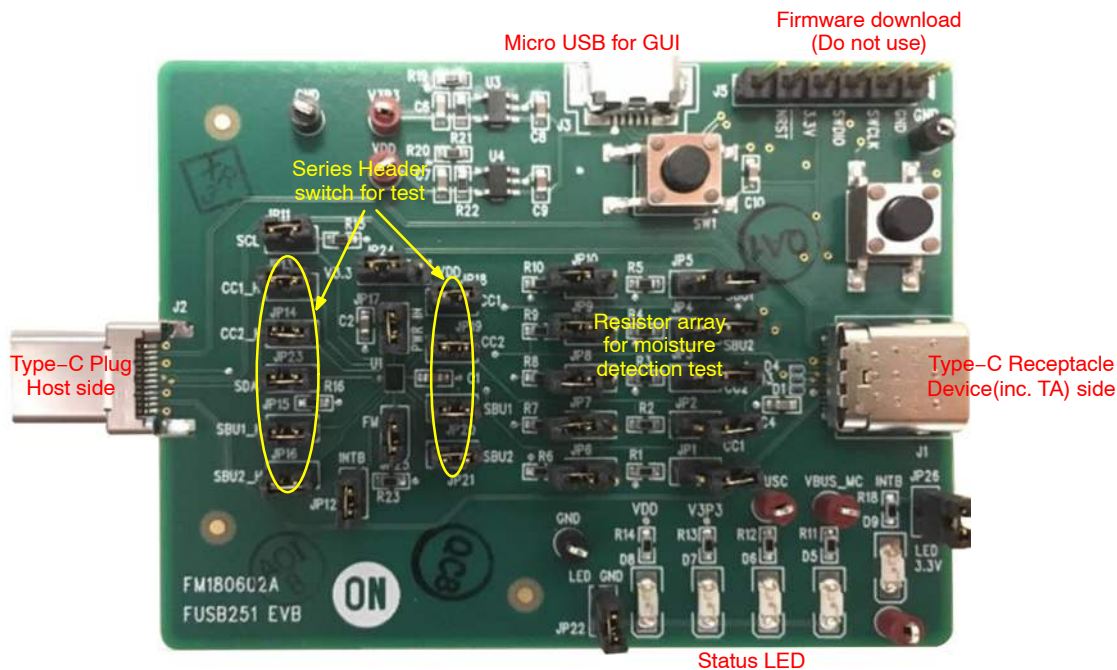

Figure 1. Applications Board Diagram

FUSB251GEVB

Power Configuration

The FUSB251 evaluation board was designed to get power from PC connection or powered externally based on the testing requirements. VBUS from micro-USB(J3) generates V3P3 through the regulator(U3) and also VDD is

generated by U4. So, in case separate external power is needed on the VDD, connect to the middle pin of JP24 which is FUSB251 VDD pin connected. JP24 is located upper of FUSB251.

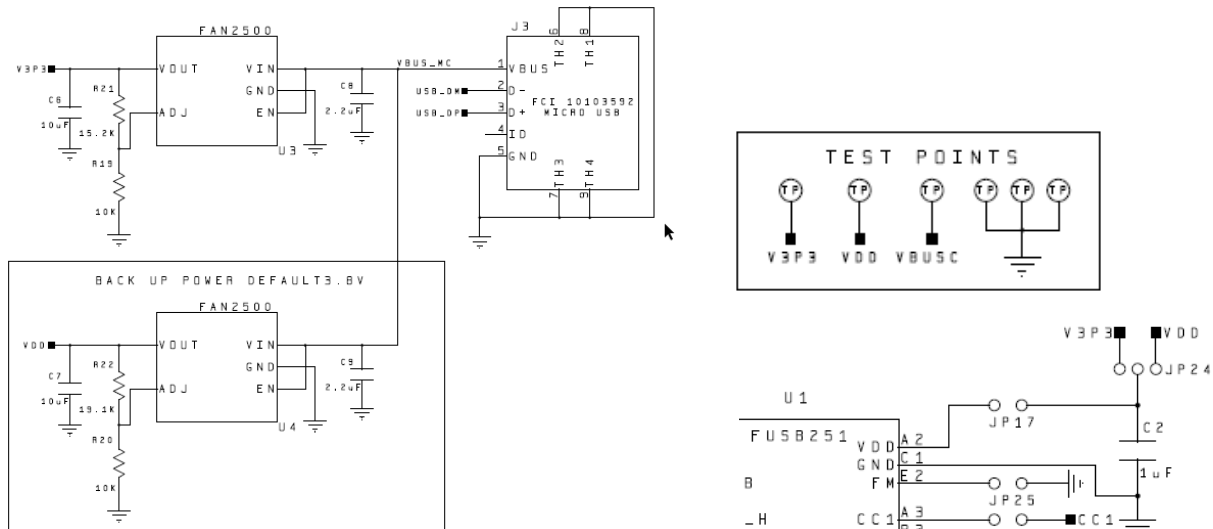

Figure 2.

Micro USB Connector and LED

The FUSB251 can fully operate from the VBUS input of the micro-B USB receptacle J3. To operate the evaluation board in this mode, just connect micro USB connector to J3, then V3P3 LED will be turned on. Also, VDD and VBUS_MC LED will be turned on. JP22 header in below schematics was prepared for turning off LED if it's not needed. VBUS_C is turned on when Vbus in Type-C port has voltage.

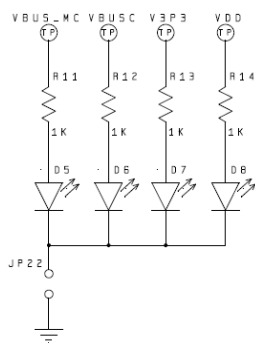

Figure 3.

FUSB251 Peripheral Block

The FUSB251 reference schematics is in below. CC1/2 connect to Type-C receptacle which will connect to devices (ie. DRP, Charger or Sink device), CC1/2_H face to host system (Type-C plug connector in this EVB). SBU is the same. FM (Factory Mode) pin can be left open or tie to GND. If it's left open (float) by removing header pin of JP25, the FM to SBU1 switch path is closed automatically after Power on reset or Device reset. SBU2 switch path will be open in the case. If FM pin connects to GND, SBU1/2 switch are closed to SBU1/2_H in default after device reset. The CAP pin is for IEC ESD protection, please add 0.1 μ F or 1 μ F capacitor. 50 volt rating capacitor is recommended because CAP pin is internally connected to CC and SBU through diode and there can be large voltage spike over 40 volt on top of 20 volt DC in case of surge event. INTB is open drain output which needs an external pull up (ex. 4.7 k Ω) to V3P3, same on SCL/SDA. Many header pins next to FUSB251 have to be populated

FUSB251GEVB

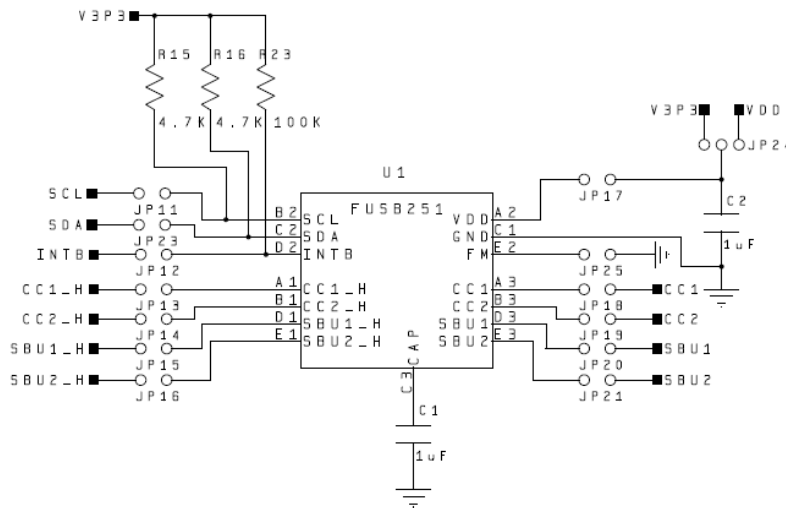

Figure 4.

Moisture Detection Test

As mentioned above, CC1/2 are for Type-C connector side (it connects to Type-C receptacle in this EVB), CC1/2_H face to Type-C/PD controller (Type-C plug in this EVB). In the board, other than CC1/2 and SBU1/2, all other signals such as DP/DM and SS signals are directly connected between Type-C receptacle and plug J1 and J2. Also, VBUS directly connects each other but there is VBUS TP to monitor VBUS during moisture test.

For moisture detection test, there are test resistors between CC1/2, SBU1/2 and GND. Each CC and SBU signal path can be connected to the other signals through the resistor as well as GND. If real moisture test is needed, do not populate header pins from JP1 to JP10. Then, CC1/2 and SBU1/2 signals directly connect to Type-C receptacle (J1). The resistor value in the board is 300 kΩ as an moisture example.

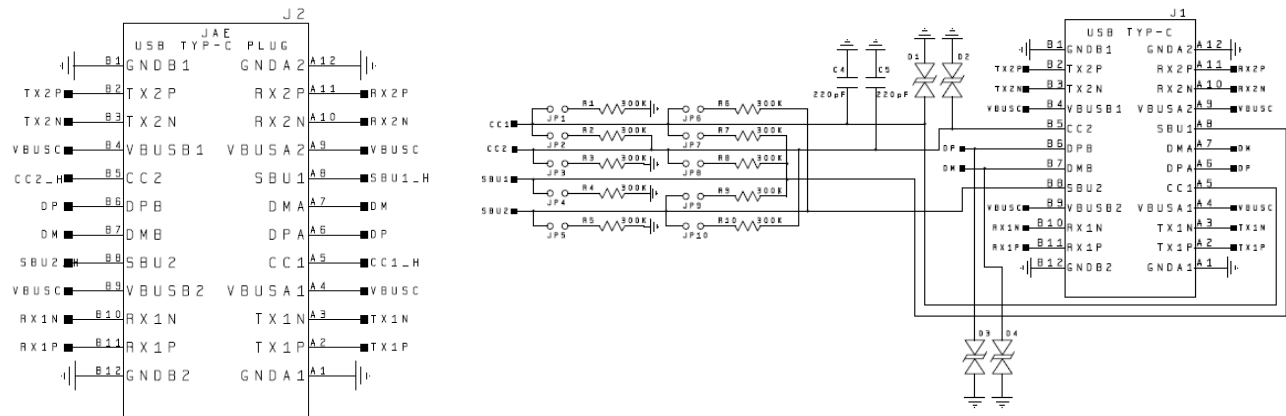

Figure 5.

I²C Communication

PC communication with the FUSB251 is done through I²C access. The evaluation board allows different ways of connecting I²C masters to the FUSB251.

Direct I²C Connection

Customers who want to directly connect their I²C masters to the evaluation board, they can connect the I²C master signals to the SCL, SDA and INTB test points. To do that, JP11, JP23 and JP12 header pins have to be unpopulated.

PC I²C Connection

The evaluation board has a STM32F072CB micro-controller on bottom side as an I²C master to control the FUSB251. This is the communication method used by the FUSB251 GUI. By connecting the PC to the micro-B USB receptacle J3, the evaluation board automatically powers the microcontroller and connects the I²C master to the FUSB251.

FUSB251GEVB

Full Schematics

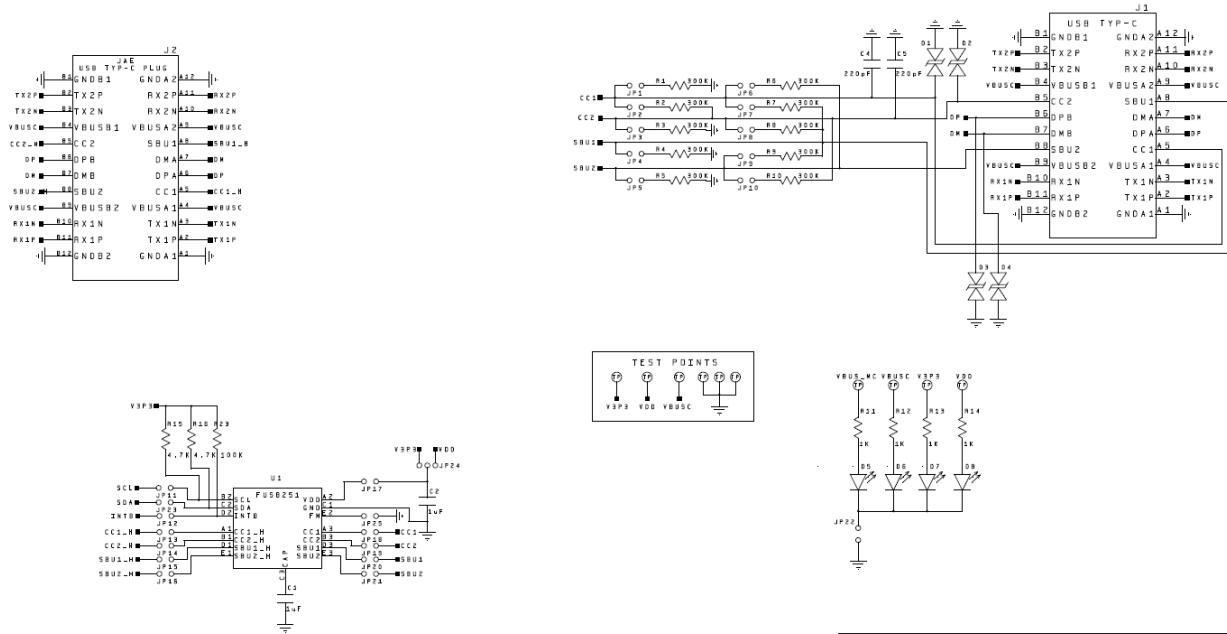

ON

82 Running Hill Rd., S. Portland, ME 04106

T4t3e FUSB251 Apps. Eval Board

Document Number
F41000033

Figure 6.

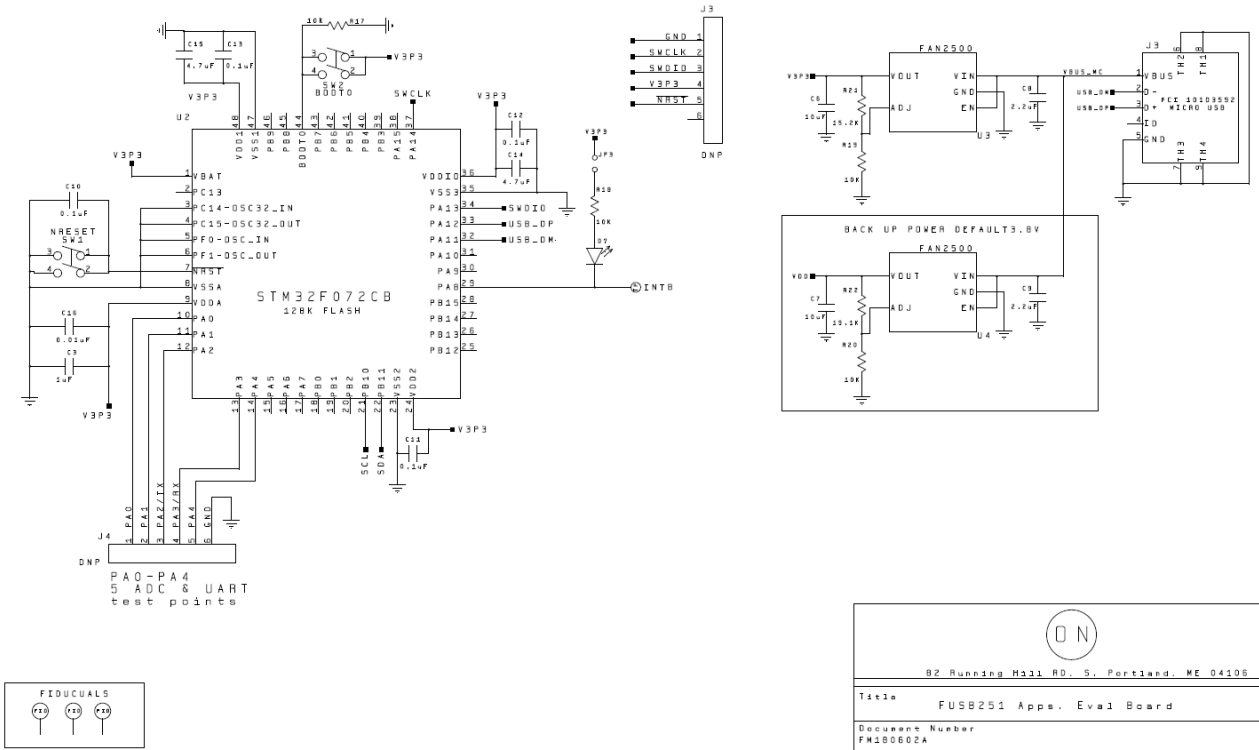

ON

82 Running Hill Rd., S. Portland, ME 04106

T4t3e FUSB251 Apps. Eval Board

Document Number
FM100602A

Figure 7.

FUSB251GEVB

FUSB251 Evaluation Platform GUI Configuration

GUI Installation

1. Locate and run the file “FUSB251_GUI.exe”. This file itself is an executable file and does not install additional software.
2. Plug the Micro-B end of the USB Cable into the GUI Interface J3 on the Evaluation Board. V3P3, VDD and VBUS_MC LEDs will illuminate if properly connected.
3. Wait for the USB Port to connect with a message in the lower left hand corner of the GUI that states “USB Device : VID: 0x0779 PID : 0x1118” and the message background should be green. And the right corner, there will be version number with device connection information, “Device Connected v4.0.0”.

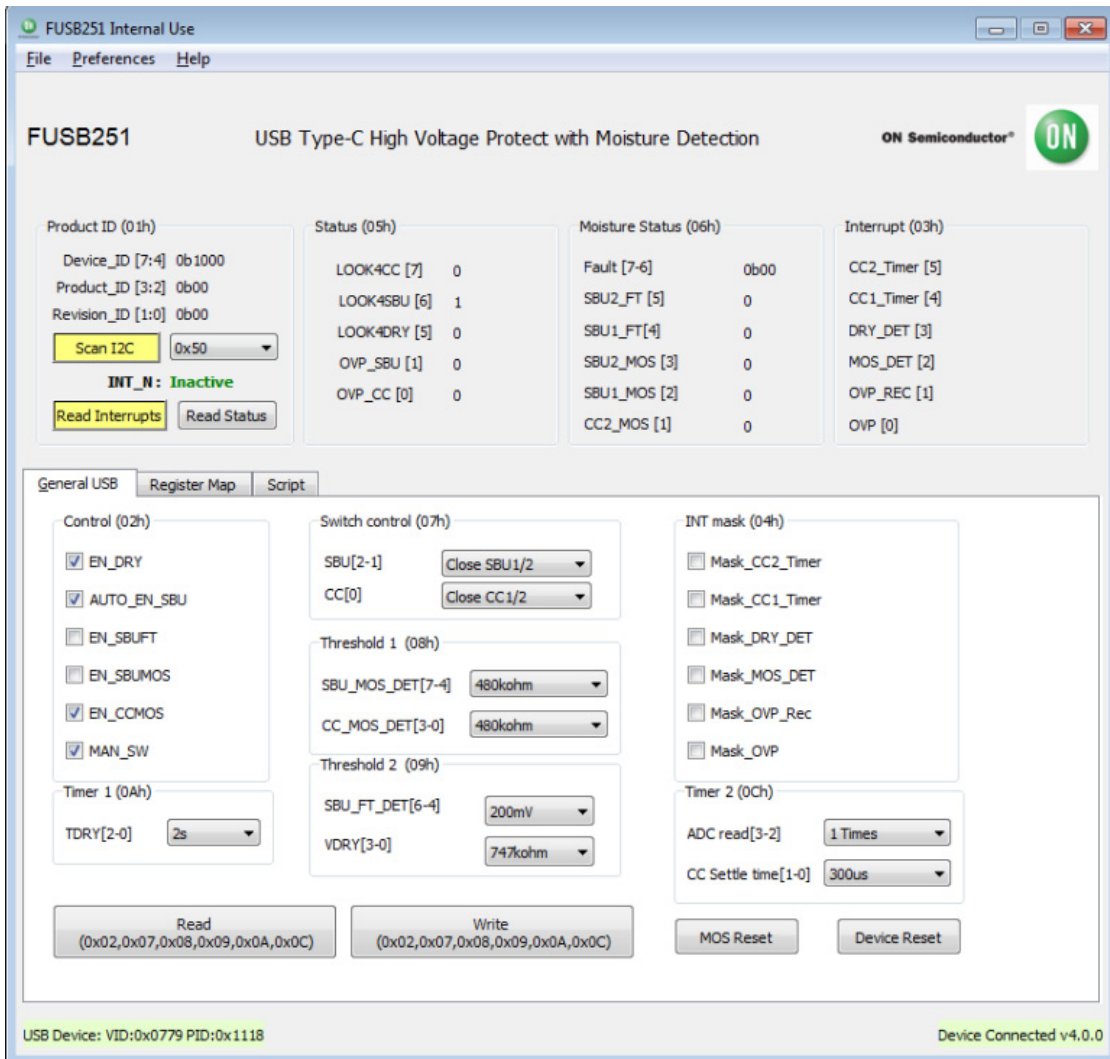

Figure 8.

FUSB251GEVB

GUI Control

1. Moisture detection can be enabled by setting the checkbox in the Control group or writing the bits directly in the register map. Once moisture detection is enabled, the Status is updated. For example, If CC moisture detection is enabled, LOOK4CC bit will be enabled in the Status. And then if Type-C accessory is attached without moisture, the Status will change to LOOK4SBU and Interrupt will occur with Timer expire by CC toggle stop, CC moisture detection stops and transits to SBU float voltage detection.
2. If moisture is detected during CC or SBU moisture detection, moisture status is updated in the MOS Status depending on moisture location. Also Status

register is updated because there is no further monitoring on moisture, and if Auto_DRY_EN was enabled, the status will change to LOOK4DRY. Interrupt register will be set as well as INTB falling low. INTB will go high again by reading the Interrupt register.

3. When moisture was detected and later, if DRY condition is detected, to restart moisture detection, disable all moisture detections and set the moisture detection again. The other way is using MOS Reset, setting MOS Reset bit will reset moisture detection state machine and re-start by enable the moisture detection.

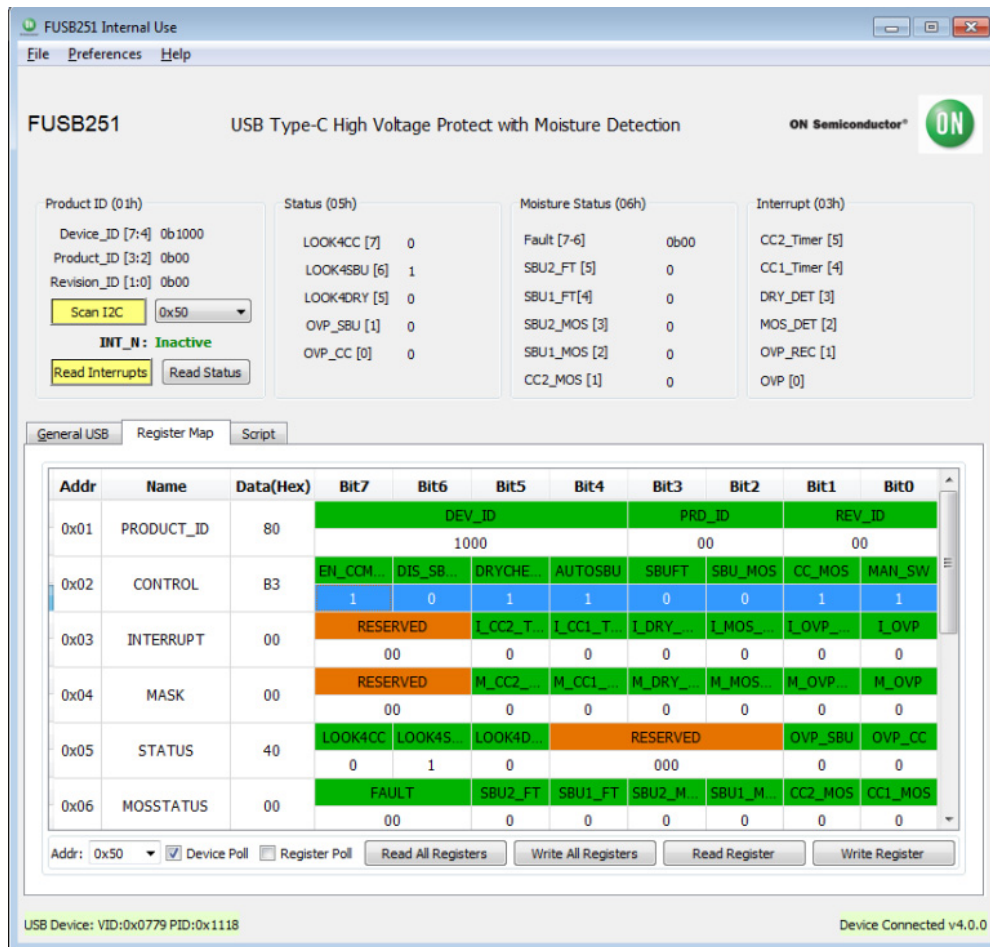

Figure 9.

onsemi, **Onsemi**, and other names, marks, and brands are registered and/or common law trademarks of Semiconductor Components Industries, LLC dba "**onsemi**" or its affiliates and/or subsidiaries in the United States and/or other countries. **onsemi** owns the rights to a number of patents, trademarks, copyrights, trade secrets, and other intellectual property. A listing of **onsemi**'s product/patent coverage may be accessed at www.onsemi.com/site/pdf/Patent-Marking.pdf. **onsemi** is an Equal Opportunity/Affirmative Action Employer. This literature is subject to all applicable copyright laws and is not for resale in any manner.

The evaluation board/kit (research and development board/kit) (hereinafter the "board") is not a finished product and is not available for sale to consumers. The board is only intended for research, development, demonstration and evaluation purposes and will only be used in laboratory/development areas by persons with an engineering/technical training and familiar with the risks associated with handling electrical/mechanical components, systems and subsystems. This person assumes full responsibility/liability for proper and safe handling. Any other use, resale or redistribution for any other purpose is strictly prohibited.

THE BOARD IS PROVIDED BY ONSEMI TO YOU "AS IS" AND WITHOUT ANY REPRESENTATIONS OR WARRANTIES WHATSOEVER. WITHOUT LIMITING THE FOREGOING, ONSEMI (AND ITS LICENSORS/SUPPLIERS) HEREBY DISCLAIMS ANY AND ALL REPRESENTATIONS AND WARRANTIES IN RELATION TO THE BOARD, ANY MODIFICATIONS, OR THIS AGREEMENT, WHETHER EXPRESS, IMPLIED, STATUTORY OR OTHERWISE, INCLUDING WITHOUT LIMITATION ANY AND ALL REPRESENTATIONS AND WARRANTIES OF MERCHANTABILITY, FITNESS FOR A PARTICULAR PURPOSE, TITLE, NON-INFRINGEMENT, AND THOSE ARISING FROM A COURSE OF DEALING, TRADE USAGE, TRADE CUSTOM OR TRADE PRACTICE.

onsemi reserves the right to make changes without further notice to any board.

You are responsible for determining whether the board will be suitable for your intended use or application or will achieve your intended results. Prior to using or distributing any systems that have been evaluated, designed or tested using the board, you agree to test and validate your design to confirm the functionality for your application. Any technical, applications or design information or advice, quality characterization, reliability data or other services provided by **onsemi** shall not constitute any representation or warranty by **onsemi**, and no additional obligations or liabilities shall arise from **onsemi** having provided such information or services.

onsemi products including the boards are not designed, intended, or authorized for use in life support systems, or any FDA Class 3 medical devices or medical devices with a similar or equivalent classification in a foreign jurisdiction, or any devices intended for implantation in the human body. You agree to indemnify, defend and hold harmless **onsemi**, its directors, officers, employees, representatives, agents, subsidiaries, affiliates, distributors, and assigns, against any and all liabilities, losses, costs, damages, judgments, and expenses, arising out of any claim, demand, investigation, lawsuit, regulatory action or cause of action arising out of or associated with any unauthorized use, even if such claim alleges that **onsemi** was negligent regarding the design or manufacture of any products and/or the board.

This evaluation board/kit does not fall within the scope of the European Union directives regarding electromagnetic compatibility, restricted substances (RoHS), recycling (WEEE), FCC, CE or UL, and may not meet the technical requirements of these or other related directives.

FCC WARNING – This evaluation board/kit is intended for use for engineering development, demonstration, or evaluation purposes only and is not considered by **onsemi** to be a finished end product fit for general consumer use. It may generate, use, or radiate radio frequency energy and has not been tested for compliance with the limits of computing devices pursuant to part 15 of FCC rules, which are designed to provide reasonable protection against radio frequency interference. Operation of this equipment may cause interference with radio communications, in which case the user shall be responsible, at its expense, to take whatever measures may be required to correct this interference.

onsemi does not convey any license under its patent rights nor the rights of others.

LIMITATIONS OF LIABILITY: **onsemi** shall not be liable for any special, consequential, incidental, indirect or punitive damages, including, but not limited to the costs of requalification, delay, loss of profits or goodwill, arising out of or in connection with the board, even if **onsemi** is advised of the possibility of such damages. In no event shall **onsemi**'s aggregate liability from any obligation arising out of or in connection with the board, under any theory of liability, exceed the purchase price paid for the board, if any.

The board is provided to you subject to the license and other terms per **onsemi**'s standard terms and conditions of sale. For more information and documentation, please visit www.onsemi.com.

ADDITIONAL INFORMATION

TECHNICAL PUBLICATIONS:

Technical Library: www.onsemi.com/design/resources/technical-documentation
onsemi Website: www.onsemi.com

ONLINE SUPPORT: www.onsemi.com/support

For additional information, please contact your local Sales Representative at www.onsemi.com/support/sales