

12:1 Dual Laser Infrared Thermometer

IR 2000A



Dual lasers for more accurate temperature and specific area measurements

**TOUGH
METER**

KLEIN TOOLS 

For Professionals... Since 1857[®] USA

Features

- Dual laser targeting
- 12:1 spot ratio
- Wide temperature measurement range
- Auto temperature scan
- 6.6 ft. (2 m) drop protection

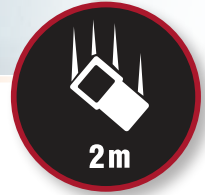

12:1 Dual Laser Infrared Thermometer IR2000A

The Klein Tools IR2000A features a wide temperature measurement range, a tight distance-to-spot ratio, auto temperature scan, a K-type thermocouple input, dual lasers, and several sampling modes to assist you in making the best possible measurements.

Dual Laser Targeting for Specific Measurement Areas:

This dual laser gun accurately measures the temperature of the target area that falls between the two laser points:

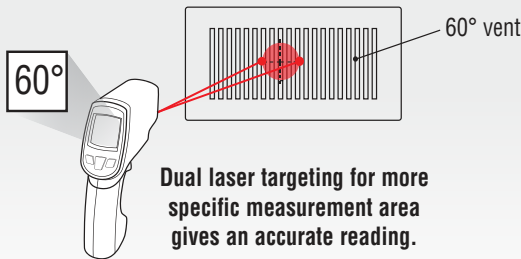

12:1 Distance To Spot Ratio for Accurate Temperature Readings:

If you are 12 feet away from an air vent, the vent should be 1 foot or less in diameter in order to attain the most accurate temperature measurement.

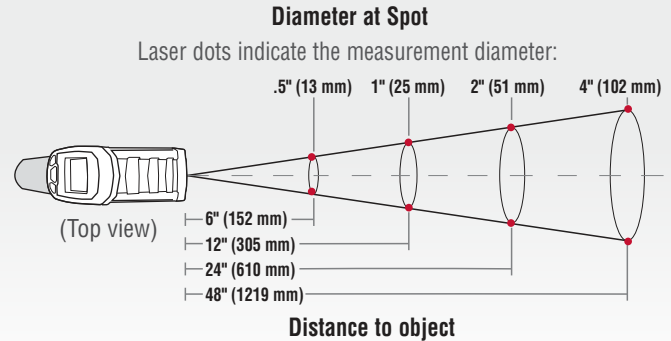

Measurement

Dual Laser Targeting		●
Temperature Range	°F/°C	-76 to 1022°F / -60 to 550°C
K-Type Thermocouple Range	°F/°C	-83.2 to 2552°F / -64 to 1400°C
Max / Min / Average / Differential	MAX/MIN	●
Backlit Display		●
Worklight		●
Emissivity		0.10 – 1.00
°F/°C Button	°F/°C	●
High/Low Alarms	HI/LO	●
Auto Power-Off	Apo	60 sec

Durability

Drop Protection		6.6 ft. (2 m)
-----------------	--	---------------

Included Items

- Case
- K-type Thermocouple
- Batteries



Cat. No.	UPC	Batteries	Height	Width	Depth	Weight (oz.)
IR2000A	69309-0	2 x AAA	6.76" (172 mm)	1.87" (48 mm)	4.7" (119 mm)	9.0 (255g)



CAUTION: Reflective materials may be hotter than indicated. Laser radiation-Do NOT stare into beam. Class 2 laser product.



See our complete line of Test and Measurement products

www.kleintools.com



© 2014 Klein Tools, Inc.
Lincolnshire, IL 60069-1418
Rev. 8/14 A 96847