

AD2700/AD2701/AD2702

FEATURES

Very High Accuracy: 10.000 Volts ±2.5mV (L and U)
Low Temperature Coefficient: 3ppm/°C
Performance Guaranteed -55°C to +125°C
10mA Output Current Capability
Low Noise
Short Circuit Protected
Available as /883B

FUNCTIONAL BLOCK DIAGRAMS

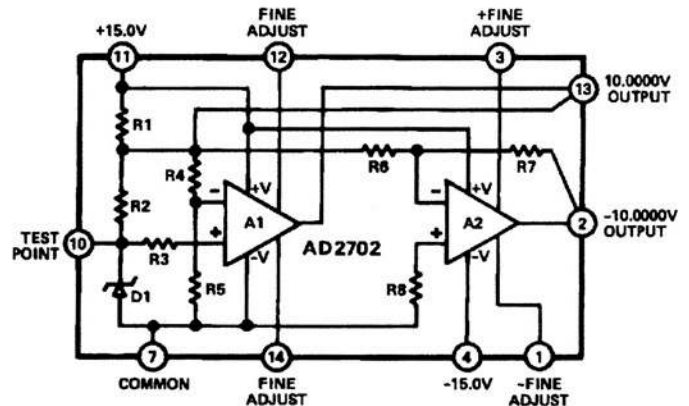
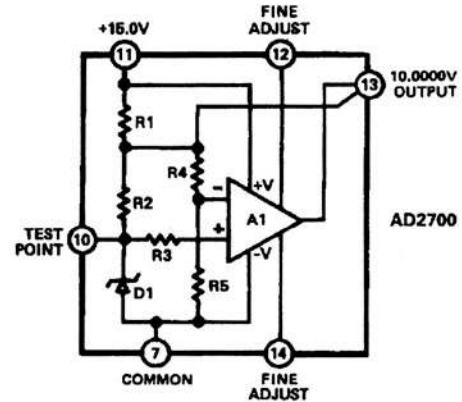

PRODUCT DESCRIPTION

The AD2700 family of precision 10 volt references offer the user excellent accuracy and stability at a moderate price by combining the recognized advantages of thin film technology and active laser trimming. The low temperature drift (3ppm/°C) achieved with these technologies can be matched only by the use of ovens, chip heaters for temperature regulation, or with hand selected components and manual trimming. In addition, temperature-regulated devices are guaranteed only up to +85°C operation, whereas the U- and S-grade devices in the AD2700 family are guaranteed to +125°C.

The AD2700 is a +10 volt reference which is designed to interface with high accuracy bipolar D/A converters of 10 and 12 bit resolution. The 10mA output drive capability also makes the AD2700 ideal for use as a general positive system reference.

The AD2701 is a negative 10 volt reference especially designed to interface with CMOS D/A and A/D converters, as shown in the applications. For systems requiring a dual tracking reference, the AD2702 offers both positive and negative precision 10 volt outputs in a single package. Both are often used with 52XX Series 12-bit A/D converters which require -10V external references for high accuracy over wide temperature ranges.

All three devices are offered in "J" and "L" grades for operation from -25°C to +85°C and "S" and "U" grades for the -55°C to +125°C temperature range. Screening to MIL-STD-883 is available for "S" and "U" grades of the AD2700 family.

PRODUCT HIGHLIGHTS

1. Active laser trimming of both initial accuracy and temperature performance results in very high accuracy over the temperature range without external components. The AD2700/01/02 LD grades have a maximum output voltage error at 25°C of ±2.5mV with no external adjustments.
2. The performance of the AD2700 series is achieved by a well-characterized design and precise control over the manufacturing process.
3. The AD2700 series is well suited for a broad range of applications requiring an accurate, stable reference source such as high resolution data converters (12 or 14 bits), test and measurement systems and calibration standards.

Model	Output
AD2700	+10.000V
AD2701	-10.000V
AD2702	±10.000V

Information furnished by Analog Devices is believed to be accurate and reliable. However, no responsibility is assumed by Analog Devices for its use; nor for any infringements of patents or other rights of third parties which may result from its use. No license is granted by implication or otherwise under any patent or patent rights of Analog Devices.

P.O. Box 280; Norwood, Massachusetts 02062 U.S.A.
 Tel: 617/329-4700
 Telex: 924491
 Twx: 710/394-6577
 Cables: ANALOG NORWOODMASS

AD2700/AD2701/AD2702—SPECIFICATIONS (max or min @ $E_m \pm 15V$ @ $+25^\circ C$, $R_L = 2k\Omega$ unless otherwise noted.)

MODEL	JD	LD	SD	UD
ABSOLUTE MAX RATINGS				
Input Voltage (for applicable supply)	$\pm 20V$	*	*	*
Power Dissipation @ $+25^\circ C$ — AD2700, 01	300mW	*	*	*
— AD2702	450mW	*	*	*
Operating Temperature Range	$-25^\circ C$ to $+85^\circ C$	*	$-55^\circ C$ to $+125^\circ C$	***
Storage Temperature Range	$-65^\circ C$ to $+150^\circ C$	*	*	*
Lead Temperature (soldering, 10s)	$+300^\circ C$	*	*	*
Short Circuit Protection (to GND)	Continuous	*	*	*
OUTPUT VOLTAGE ERROR @ $+25^\circ C$				
AD2700 10.000V	$\pm 0.005V$	$\pm 0.0025V$	*	**
AD2701 -10.000V	$\pm 0.005V$	$\pm 0.0025V$	*	**
AD2702 $\pm 10.000V$	$\pm 0.005V$	$\pm 0.0025V$	*	**
OUTPUT CURRENT¹ — @ $+25^\circ C$				
($V_{IN} = \pm 13$ to $\pm 18V$) over op. temp. range	$\pm 10mA$	*	*	*
	$\pm 5mA$	$+5mA, -2mA$	**	**
OUTPUT VOLTAGE ERROR — AD2700, 01				
(T_{min} to T_{max}) ²	10ppm/ $^\circ C$	3ppm/ $^\circ C$	**	**
	$\pm 11.0mV$	$\pm 4.3mV$	$\pm 8mV$	$\pm 5.5mV$
AD2702	10ppm/ $^\circ C$	5ppm/ $^\circ C$	**	3ppm/ $^\circ C$
	$\pm 11.0mV$	$\pm 5.5mV$	$\pm 10.0mV$	$\pm 5.5mV$
LINE REGULATION				
$V_{IN} = \pm 13.5$ to $\pm 16.5V$	300 $\mu V/V$	*	*	*
LOAD REGULATION				
0 to $\pm 10mA$	50 $\mu V/mA$	*	*	*
OUTPUT RESISTANCE				
	0.05 Ω	*	*	*
INPUT VOLTAGE, OPERATING				
	$\pm 13V$ to $\pm 18V$	*	*	*
QUIESCENT CURRENT — AD2700, 01				
	$\pm 14mA$	*	*	*
— AD2702	$+17mA, -4mA$	*	*	*
NOISE				
(0.1 to 10Hz)	50 μV p-p typ	*	*	*
LONG TERM STABILITY (@ $+55^\circ C$)				
	100ppm/1000 Hrs. (typ)	*	*	*
OFFSET ADJUST RANGE				
(Sec Diagrams)	$\pm 20mV$ (min)	*	*	*
OFFSET ADJUST TEMP DRIFT EFFECT				
	$\pm 4\mu V/^\circ C$ per mV of Adjust (typ)	*	*	*
PACKAGE OPTION^{3,4}				
	DH-14C	DH-14C	DH-14C	DH-14C

NOTES

*Same as "JD" grade performance.

**Same as "LD" grade performance.

***Same as "SD" grade performance.

¹ Specified with resistive load to common. Device not intended for use in driving a dynamic load.

² Output voltage error as a function of temperature is determined using the box method. Each unit is tested at T_{min} , T_{max} and $+25^\circ C$. At each temperature V_{OUT} must fall within the rectangular area bounded by the minimum and maximum temperature and whose maximum V_{OUT} value is equal to V_{OUT} nominal plus or minus the maximum $+25^\circ C$ error plus the maximum drift error from $+25^\circ C$. The box limits are noted below the drift values used to calculate the box.

³ Analog Devices reserves the right to ship side-braced ceramic packages (outline DH-14D) in lieu of the standard ceramic packages for J and L grade parts.

⁴ See Section 14 for package outline information.

Specifications subject to change without notice.

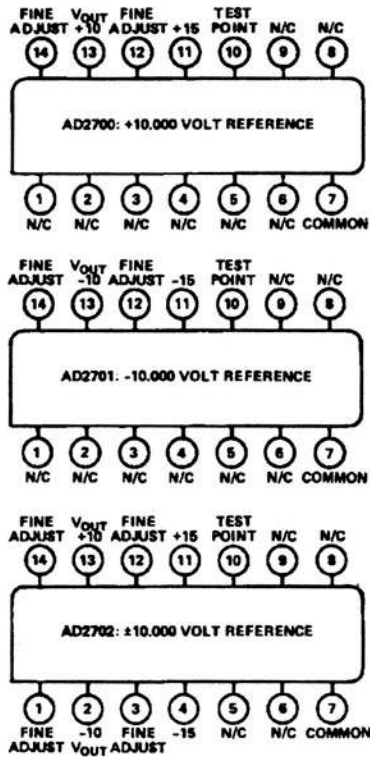

Pin Designations

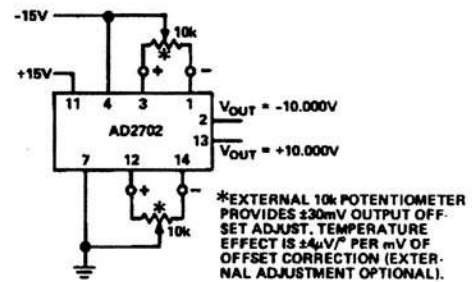
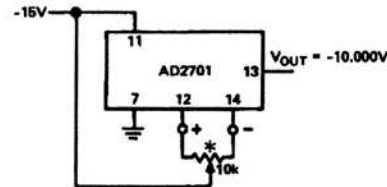
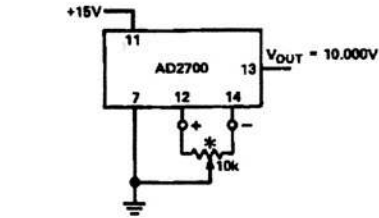

Fine Trim Connections

USING AD2700 REFERENCE WITH THE AD7520 AND AN IC AMPLIFIER TO BUILD A DAC

The AD2700 series is ideal for use with the AD7520 series of CMOS D/A converters. A CMOS converter in a unipolar application as shown below performs an inversion of the voltage reference input. Thus, use of the +10 volt AD2700 reference will result in a 0 to -10 volt output range. Alternatively, using

the -10 volt AD2701 will result in a 0 to +10 volt range. Two operational amplifiers are used to give a bipolar output range of -10 volt to +10 volt, as shown in the lower figure. Either the AD2700 or AD2701 can be used, depending on the transfer code characteristic desired. For more detailed applications information, refer to the AD7520 Data Sheet.

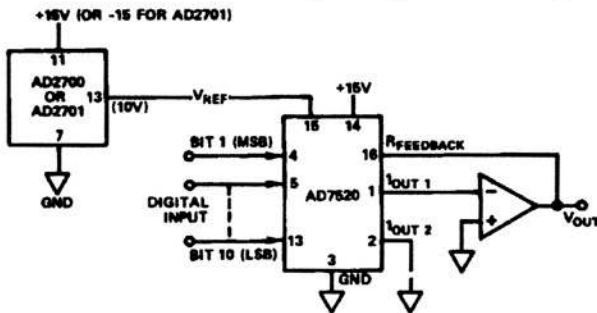

Unipolar Binary Operation

DIGITAL INPUT	ANALOG OUTPUT
1111111111	$-V_{REF} (1 - 2^{-10})$
1000000001	$-V_{REF} (1/2 + 2^{-10})$
1000000000	$\frac{-V_{REF}}{2}$
0111111111	$-V_{REF} (1/2 - 2^{-10})$
0000000001	$-V_{REF} (2^{-10})$
0000000000	0

NOTE: 1 LSB = $2^{-10} V_{REF}$

Table I. Code Table – Unipolar Binary Operation

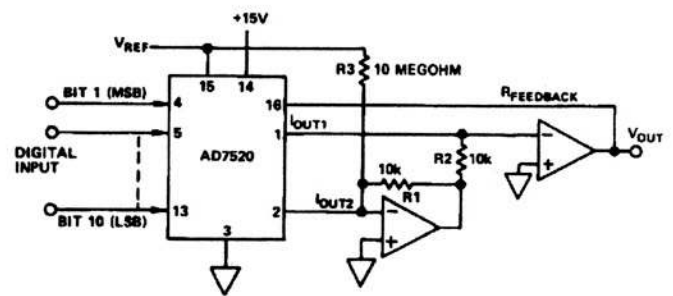

Bipolar Operation (4-Quadrant Multiplication)

DIGITAL INPUT	ANALOG OUTPUT
1111111111	$-V_{REF} (1 - 2^{-9})$
1000000001	$-V_{REF} (2^{-9})$
1000000000	0
0111111111	$V_{REF} (2^{-9})$
0000000001	$V_{REF} (1 - 2^{-9})$
0000000000	V_{REF}

NOTE: 1 LSB = $2^{-9} V_{REF}$

Table II. Code Table – Bipolar (Offset Binary) Operation

AD2700/AD2701/AD2702

USING THE AD2700 VOLTAGE REFERENCE WITH D/A CONVERTER

An AD2700 Voltage Reference can be used with an inverting operational amplifier and an R-2R ladder network. If all bits but the MSB are off (i.e., grounded), the output voltage is $(-R/2R)E_{REF}$. If all bits but Bit 2 are off, it can be shown that the output voltage is $\frac{1}{2}(-R/2R)E_{REF} = \frac{1}{4}E_{REF}$: The lumped resistance of all the less-significant-bit circuitry (to the left of Bit 2) is $2R$; the Thevenin equivalent looking back from the MSB towards Bit 2 is the generator, $E_{REF}/2$, and the series resistance $2R$; since the grounded MSB series

resistance, $2R$, has virtually no influence — because the amplifier summing point is at virtual ground — the output voltage is therefore $-E_{REF}/4$. The same line of thinking can be employed to show that the n th bit produces an increment of output equal to $2^{-n} E_{REF}$.

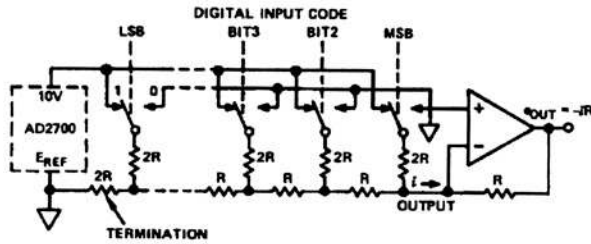

a. Basic Circuit

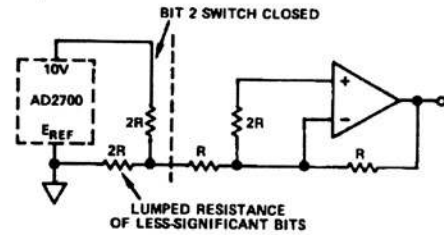

b. Example: Contribution of Bit 2; All Other Bits "0"

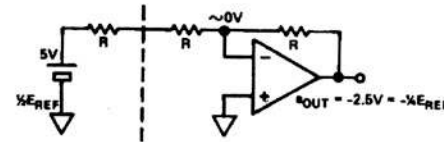

c. Simplified Equivalent of Circuit (b.)

PACKAGE DIMENSIONS

Dimensions shown in inches and (mm).

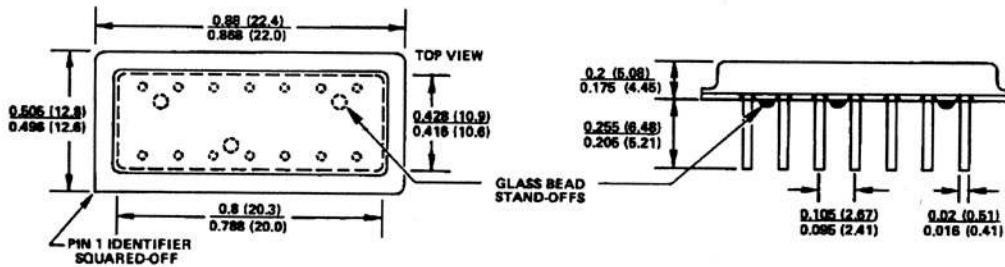

Hermetically sealed 14-Pin Dual-In-Line (Gross leak tested per MIL-STD-883, Method 1014)
Pin 7 is electrically connected to the case. Case has metal bottom surface.

14-Pin Dual-In-Line Metal Package

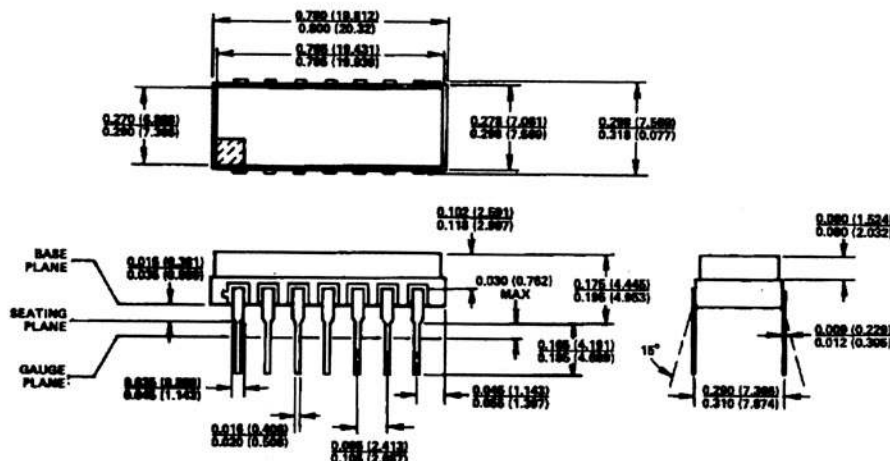

14-Pin Dual-In-Line Ceramic Package