

【1. 適用範囲 SCOPE】

本仕様書は、_____ に納入する
Pico-Lock 1.0 電線対基板 コネクタ (1列 R/A SMT金めっき品) について規定する。
 This product specification covers the performance requirements for Pico-Lock 1.0 WIRE TO BOARD CONNECTOR (SINGLE-ROW R/A SMT GOLD PLATING) series, for _____.

【2. 製品名称及び型番 PRODUCT NAME AND PART NUMBER】

製品名称 Product Name	製品型番 Part Number	
リセプタクル ハウジング Receptacle Housing	503764****	
リセプタクル ターミナル Receptacle Terminal	AWG #28 - #30	5037650098
ヘッダーハウジングアセンブリ (エンボス梱包) Header Housing Assembly (Embossed PKG)	503763****	

* : 図面参照 Refer to the drawing
 取扱についてはコネクタ取扱説明書”AS-503764-001参照願います。
 Instruction manual : Refer to Application specification AS-503764-001

REV.	G																			
SHEET	1-20																			
REVISE ON PC ONLY										TITLE:										
G	変更 REVISED EC NO.: 636787 2020/4/27 QHE31					Pico-Lock 1.0 W/B SINGLE-ROW R/A SMT GOLD PLATING 製品仕様書														
	THIS DOCUMENT CONTAINS INFORMATION THAT IS PROPRIETARY TO MOLEX ELECTRONIC TECHNOLOGIES, LLC AND SHOULD NOT BE USED WITHOUT WRITTEN PERMISSION																			
REV.	DESCRIPTION																			
DESIGN CONTROL J					STATUS					WRITTEN BY: T.HANYU	CHECKED BY: K.ASAKAWA	APPROVED BY: Y.ITO	DATE: 2013/09/20							
DOCUMENT NUMBER PS-503764-001										DOC. TYPE PS	DOC. PART 001	CUSTOMER GENERAL						SHEET 1 OF 20		

【 3. 定格及び適用電線 RATINGS AND APPLICABLE WIRE 】

項目 Item	規格 Standard			
最大許容電圧 Allowable Voltage (MAX)	150 V		[AC (実効値 rms) / DC]	
最大許容電流 *4*5*6*7*8 Allowable Current (MAX)	AWG	2 circuits	3~4 circuits	5~6 circuits
		Amps (A)	Amps (A)	Amps (A)
	28	2.5	2.0	1.5
	30	2.0	1.5	1.5
適用電線 Applicable wires	被覆外径 : ϕ 0.5mm- ϕ 0.7mm Insulation O.D. : ϕ 0.5mm- ϕ 0.7mm			
使用温度範囲 *1*2*3 Ambient Temperature Range	-40°C ~ +105°C 低温において氷結しないこと Not freeze to low temperature			

- *1 : 基板実装後の無通電状態は、使用温度範囲が適用されます。
Non-operating connectors after reflow must follow the operating temperature range condition.
- *2 : 通電による温度上昇分を含む。
This includes the terminal temperature rise generated by conducting electricity.
- *3 : 適合電線も本使用温度範囲を満足すること。
Applicable wires must also meet the specified temperature range.
- *4 : 閾値は温度上昇30°C以下としています。
Current deratings are based on not exceeding 30°C Temperature Rise.
- *5 : 温度上昇の測定は圧着端子のバレル部にて実施しています。
Temperature Rise is measured in barrel area of crimp terminal.
- *6 : 基板デザインにより温度上昇の結果が異なります。
PCB trace design can greatly affect temperature rise results.
- *7 : 全極に通電し測定しています。
Data is for all circuits powered.
- *8 : ピンアサインは7項に基づく。
Pin assign: refer to paragraph 7.

REVISE ON PC ONLY		TITLE:			
G	SEE SHEET 1 OF 20	Pico-Lock 1.0 W/B SINGLE-ROW R/A SMT GOLD PLATING			
	REV.	DESCRIPTION	THIS DOCUMENT CONTAINS INFORMATION THAT IS PROPRIETARY TO MOLEX ELECTRONIC TECHNOLOGIES, LLC AND SHOULD NOT BE USED WITHOUT WRITTEN PERMISSION		
DOCUMENT NUMBER PS-503764-001		DOC. TYPE PS	DOC. PART 001	CUSTOMER GENERAL	SHEET 2 OF 20

【4. 性能 PERFORMANCE】

4-1. 電気的性能 Electrical performance

項目 Item		条件 Test Condition	規格 Requirement
4-1-1	接触抵抗 Contact Resistance	コネクタを嵌合させ、開放電圧 20mV以下、短絡電流 10mA 以下にて測定する。 (測定箇所は、8項に基づく) (JIS C5402-2-1) Mate connectors and measured by dry circuit, 20mV MAX, 10mA MAX. (Refer to Paragraph 8) (JIS C5402-2-1)	20 milliohms MAX
4-1-2	絶縁抵抗 Insulation Resistance	コネクタを嵌合させ、隣接するターミナル間及びターミナル、アース間に、DC 500Vを印加し測定する。 (JIS C5402-3-1/MIL-STD-202 試験法 302) Mate connectors and apply 500V DC between adjacent terminal or ground. (JIS C5402-3-1/MIL-STD-202 Method 302)	1000 Megaohms MIN
4-1-3	耐電圧 Voltage Proof	コネクタを嵌合させ、隣接するターミナル間及びターミナル、アース間に、AC 500V (実効値)を1分間印加する。 (JIS C5402-4-1 / MIL-STD-202 試験法 301) Mate connectors, apply 500V AC (rms) for 1 minute between adjacent terminals or terminal and ground. (JIS C5402-4-1 / MIL-STD-202 Method 301)	製品機能を損なう異常なきこと No Damage on function
4-1-4	圧着部接触抵抗 Contact Resistance on Crimped Portion	ターミナルに適合電線を圧着し、開放電圧20mV以下、短絡電流 10mA 以下にて測定する。 Crimp the applicable wire to the terminal, measured by dry circuit, 20mV MAX, 10mA MAX.	5 milliohms MAX

REVISE ON PC ONLY

G

SEE SHEET 1 OF 20

TITLE:

Pico-Lock 1.0 W/B
SINGLE-ROW R/A SMT GOLD PLATING

製品仕様書

THIS DOCUMENT CONTAINS INFORMATION THAT IS PROPRIETARY TO MOLEX ELECTRONIC TECHNOLOGIES, LLC AND SHOULD NOT BE USED WITHOUT WRITTEN PERMISSION

REV.

DESCRIPTION

DOCUMENT NUMBER
PS-503764-001

DOC. TYPE
PS

DOC. PART
001

CUSTOMER
GENERAL

SHEET
3 OF 20

4-2. 機械的性能 Mechanical Performance

項目 Item		条件 Test Condition		規格 Requirement
4-2-1	挿入力及び抜去力 Insertion and Withdrawal Force	毎分25±3mmの速さで挿入、抜去を行う。 Insert and withdraw connectors at the speed rate of 25±3mm/minute.		第6項参照 Refer to paragraph 6
4-2-2	圧着部引張強度 Crimping Pull out Force	圧着されたターミナルを治具に 固定し、電線を軸方向に 毎分25±3mmの速さで引張る。 (JIS C5402-16-4)	AWG#28	9.8 N {1.0kgf} MIN
		Fix the crimped terminal to the jig, apply axial pull out force on the wire at the speed rate of 25±3 mm/minute. (JIS C5402-16-4)	AWG#30	4.9 N {0.5kgf} MIN
4-2-3	圧着端子挿入力 Crimp Terminal Insertion Force	圧着されたターミナルをハウジングに挿入する。 Insert the crimped terminal into the housing.		14.7 N { 1.5kgf} MAX
4-2-4	圧着端子保持力 Crimp Terminal Retention Force	ハウジングに装着した圧着されたターミナルを 毎分 25±3mm の速さで引張る。 Apply axial pull out force at the speed rate of 25±3 mm/minute on the crimped terminal assembled in the housing.		4 N {0.4kgf} MIN
4-2-5	HDR端子保持力 Header Terminal Retention Force	ハウジングに装着されたターミナルを 毎分 25±3mm の速さで軸方向に引張る。 Apply axial pull out force at the speed rate of 25±3mm/minute on the terminal assembled in the housing.		0.5 N {0.05 kgf} MIN
4-2-6	ハウジングロック強度 (ポジティブロック) Housing Lock Strength (Positive Lock)	コネクタを嵌合させ、軸方向に毎分25±3mmの 速さで引張る。 Mate connectors and apply axial pull out force at the speed rate of 25±3mm/minute.		5 N {0.5 kgf} MIN

REVISE ON PC ONLY		TITLE: Pico-Lock 1.0 W/B SINGLE-ROW R/A SMT GOLD PLATING 製品仕様書
G	SEE SHEET 1 OF 20	
REV.	DESCRIPTION	THIS DOCUMENT CONTAINS INFORMATION THAT IS PROPRIETARY TO MOLEX ELECTRONIC TECHNOLOGIES, LLC AND SHOULD NOT BE USED WITHOUT WRITTEN PERMISSION

DOCUMENT NUMBER PS-503764-001	DOC. TYPE PS	DOC. PART 001	CUSTOMER GENERAL	SHEET 4 OF 20
---	------------------------	-------------------------	----------------------------	------------------

4-3. 環境性能、その他 Environmental Performance and Others

項 目 Item		条 件 Test Condition	規 格 Requirement	
4-3-1	繰り返し挿抜 Repeated Insertion / Withdrawal	1分間10回以下の速さで、挿入、抜去を30回繰返す。 Insert and withdraw connectors 30 cycles repeatedly by rate of less than 10 cycles per minute.	接 触 抵 抗 Contact Resistance	40 milliohms MAX
4-3-2	温 度 上 昇 Temperature Rise	コネクタを嵌合させ、全ての圧着端子を直列に接続し最大許容電流で熱平衡に達した時の温度上昇を測定する。(UL498) (回路構成については7項に基づく) Mate connectors and all crimp terminals shall be connected in a direct series. The temperature rise shall be measured when the terminal reaches terminal equilibrium allowable current. (UL498) (Circuit Structure : Refer to Paragraph 7)	温 度 上 昇 Temperature Rise	30 °C MAX
4-3-3	耐 振 動 性 Vibration	コネクタを嵌合させ、DC 1.0 mA 通電状態にて、嵌合軸を含む互いに垂直な 3方向に掃引割合 10~55~10 Hz/分、全振幅 1.5mm の振動を各2時間 加える。(ケーブルは固定すること) (JIS C 60068-2-6/MIL-STD-202 試験法 201) Mate connectors and subject to the following vibration conditions, for a period of 2 hours in each of 3 mutually perpendicular axes, passing DC 1mA during the test. (Fix the cable at test.) Amplitude : 1.5mm P-P Frequency : 10~55~10 Hz in 1 minute. Duration : 2 hours in each X.Y.Z.axes (JIS C 60068-2-6/MIL-STD-202 Method 201)	外 観 Appearance	製品機能を損なう異常なきこと No Damage on function
			接 触 抵 抗 Contact Resistance	40 milliohms MAX
			瞬 断 Discontinuity	1.0 micro second MAX

REVISE ON PC ONLY	
G	SEE SHEET 1 OF 20
REV.	DESCRIPTION

TITLE:	Pico-Lock 1.0 W/B SINGLE-ROW R/A SMT GOLD PLATING 製品仕様書
THIS DOCUMENT CONTAINS INFORMATION THAT IS PROPRIETARY TO MOLEX ELECTRONIC TECHNOLOGIES, LLC AND SHOULD NOT BE USED WITHOUT WRITTEN PERMISSION	

DOCUMENT NUMBER PS-503764-001	DOC. TYPE PS	DOC. PART 001	CUSTOMER GENERAL	SHEET 5 OF 20
----------------------------------	-----------------	------------------	---------------------	------------------

項 目 Item		条 件 Test Condition	規 格 Requirement	
4-3-4	耐 衝 撃 性 Mechanical Shock	コネクタを嵌合させ、DC 1.0 mA 通電状態にて、テストパルス半周期、嵌合軸を含む互いに垂直な6方向に490m/s ² { 50G }、作用時間11msの衝撃を各3回、合計18回加える。 (JIS C60068-2-27/MIL-STD-202 試験法 213) Mate connectors and subject to the following shock conditions. 3 times shocks shall be applied 6 directions along 3 mutually perpendicular axes, passing DC 1 mA current during the test. (Total of 18 shocks) Test pulse : Half Sine Peak value : 490 m/s ² (50 G) Duration : 11 ms (JIS C60068-2-27/MIL-STD-202 Method 213)	外 観 Appearance	製品機能を損なう異常なきこと No Damage on function
			接 触 抵 抗 Contact Resistance	40 milliohms MAX
			瞬 断 Discontinuity	1.0 micro second MAX

REVISE ON PC ONLY

G

SEE SHEET 1 OF 20

TITLE:

Pico-Lock 1.0 W/B
SINGLE-ROW R/A SMT GOLD PLATING

製品仕様書

THIS DOCUMENT CONTAINS INFORMATION THAT IS PROPRIETARY TO MOLEX ELECTRONIC TECHNOLOGIES, LLC AND SHOULD NOT BE USED WITHOUT WRITTEN PERMISSION

REV.

DESCRIPTION

DOCUMENT NUMBER
PS-503764-001

DOC. TYPE
PS

DOC. PART
001

CUSTOMER
GENERAL

SHEET
6 OF 20

項目 Item		条件 Test Condition	規格 Requirement	
4-3-5	耐熱性 Heat Resistance	コネクタを嵌合させ、105±2°Cの雰囲気中に96時間放置後取り出し、1~2時間室温に放置する。 (JIS C60068-2-2/MIL-STD-202 試験法 108) Mate connectors and expose to 105±2°C for 96 hours. Upon completion of the exposure period, the test specimens shall be conditioned at ambient room conditions for 1 to 2 hours, after which the specified measurements shall be performed. (JIS C60068-2-2/MIL-STD-202 Method 108)	外観 Appearance	製品機能を損なう異常なきこと No Damage on function
			接触抵抗 Contact Resistance	40 milliohms MAX
4-3-6	耐寒性 Cold Resistance	コネクタを嵌合させ、-40±3°Cの雰囲気中に96時間放置後取り出し、1~2時間室温に放置する。(JIS C60068-2-1) Mate connectors and expose to -40±3°C for 96 hours. Upon completion of the exposure period, the test specimens shall be conditioned at ambient room conditions for 1 to 2 hours, after which the specified measurements shall be performed. (JIS C60068-2-1)	外観 Appearance	製品機能を損なう異常なきこと No Damage on function
			接触抵抗 Contact Resistance	40 milliohms MAX
4-3-7	耐湿性 Humidity	コネクタを嵌合させ、40±2°C、相対湿度90~95%の雰囲気中に96時間放置後取り出し、1~2時間室温に放置する。 (JIS C60068-2-78/MIL-STD-202 試験法 103) Mate connectors and expose to 40±2°C, relative humidity 90 to 95% for 96 hours. Upon completion of the exposure period, the test specimens shall be conditioned at ambient room conditions for 1 to 2 hours, after which the specified measurements shall be performed. (JIS C60068-2-78/MIL-STD-202 Method 103)	外観 Appearance	製品機能を損なう異常なきこと No Damage on function
			接触抵抗 Contact Resistance	40 milliohms MAX
			絶縁抵抗 Insulation Resistance	100 Megaohms MIN
			耐電圧 Dielectric Strength	4-1-3項満足のこと Must meet 4-1-3

REVISE ON PC ONLY	
G	SEE SHEET 1 OF 20
REV.	DESCRIPTION

TITLE:	Pico-Lock 1.0 W/B SINGLE-ROW R/A SMT GOLD PLATING	
	製品仕様書	
THIS DOCUMENT CONTAINS INFORMATION THAT IS PROPRIETARY TO MOLEX ELECTRONIC TECHNOLOGIES, LLC AND SHOULD NOT BE USED WITHOUT WRITTEN PERMISSION		

DOCUMENT NUMBER PS-503764-001	DOC. TYPE PS	DOC. PART 001	CUSTOMER GENERAL	SHEET 7 OF 20
---	------------------------	-------------------------	----------------------------	------------------

項 目 Item		条 件 Test Condition	規 格 Requirement	
4-3-8	温度サイクル Temperature Cycling	<p>コネクタを嵌合させ、$-40\pm 3^{\circ}\text{C}$に30分、$+105\pm 2^{\circ}\text{C}$に 30分。これを1サイクルとし、5サイクル 繰返す。 但し、温度移行時間は 5分以内 とする。 試験後1~2時間 室温に放置する。 (JIS C60068-2-14)</p> <p>Mate connectors and subject to the following conditions for 5 cycles. Upon completion of the exposure period, the test specimens shall be conditioned at ambient room conditions for 1 to 2 hours, after which the specified measurements shall be performed. 5 cycles of :</p> <p>a) $-40\pm 3^{\circ}\text{C}$ 30 minutes b) $+105\pm 2^{\circ}\text{C}$ 30 minutes Shift time : Within 5 minutes (JIS C60068-2-14)</p>	外 観 Appearance	製品機能を損なう 異常なきこと No Damage on function
			接 触 抵 抗 Contact Resistance	40 milliohms MAX
4-3-9	塩 水 噴 霧 Salt Spray	<p>コネクタを嵌合させ、$35\pm 2^{\circ}\text{C}$にて$5\pm 1\%$重量比の塩水を 48 ± 4時間噴霧し、試験後常温で水洗いした後、室温で乾燥させる。 (JIS C60068-2-11/MIL-STD-202 試験法101)</p> <p>Mate connectors and expose to the following salt mist conditions. Upon completion of the exposure period, salt deposits shall be removed by a gentle wash or dip in running water, after which the specified measurements shall be performed. NaCl solution Concentration : $5\pm 1\%$ Spray time : 48 ± 4 hours Ambient temperature : $35\pm 2^{\circ}\text{C}$ (JIS 60068-2-11/MIL-STD-202 Method 101)</p>	外 観 Appearance	製品機能を損なう 異常なきこと No Damage on function
			接 触 抵 抗 Contact Resistance	40 milliohms MAX

REVISE ON PC ONLY

G

SEE SHEET 1 OF 20

TITLE:

Pico-Lock 1.0 W/B
SINGLE-ROW R/A SMT GOLD PLATING

製品仕様書

THIS DOCUMENT CONTAINS INFORMATION THAT IS PROPRIETARY TO MOLEX ELECTRONIC TECHNOLOGIES, LLC AND SHOULD NOT BE USED WITHOUT WRITTEN PERMISSION

REV.

DESCRIPTION

DOCUMENT NUMBER
PS-503764-001

DOC. TYPE
PS

DOC. PART
001

CUSTOMER
GENERAL

SHEET
8 OF 20

項 目 Item		条 件 Test Condition	規 格 Requirement	
4-3-10	耐亜硫酸ガス SO ₂ Gas	コネクタを嵌合させ、40±2°Cにて 50±5ppmの亜硫酸ガス中に24時間放置す る。 Mated connectors and expose to the conditions of 50±5ppm SO ₂ gas ambient temperature 40±2°C for 24 hours.	外 観 Appearance	製品機能を損なう 異常なきこと No Damage on function
			接 触 抵 抗 Contact Resistance	40 milliohms MAX

REVISE ON PC ONLY		TITLE:			
G	SEE SHEET 1 OF 20	Pico-Lock 1.0 W/B SINGLE-ROW R/A SMT GOLD PLATING 製品仕様書			
	REV.	DESCRIPTION	THIS DOCUMENT CONTAINS INFORMATION THAT IS PROPRIETARY TO MOLEX ELECTRONIC TECHNOLOGIES, LLC AND SHOULD NOT BE USED WITHOUT WRITTEN PERMISSION		
DOCUMENT NUMBER PS-503764-001		DOC. TYPE PS	DOC. PART 001	CUSTOMER GENERAL	SHEET 9 OF 20
EN-127(2015-12)					

項 目 Item		条 件 Test Condition	規 格 Requirement	
4-3-11	はんだ付け性 Solderability	ターミナルまたはピンをフラックスに浸し、本体の取付け基準面より0.2mm迄、245±3°Cのはんだに3±0.5秒浸す。 Dip terminal or pin into flux, and immerse the area up to 0.2mm from the bottom of the housing into solder molten at 245±3°C for 3±0.5 sec.	濡れ性 Solder Wetting	ピンホールや隙間なく浸漬面積の95%以上 95% of immersed area must show no voids, pin holes.
4-3-12	はんだ耐熱性 Resistance to Soldering Heat	赤外線リフロー時 (Reflow by IR Reflow Machine) 第9項の推奨温度プロファイル条件にてリフローを行う。 Using the reflow profile condition below paragraph 9, the product was reflowed.	外 観 Appearance	端子ガタ、割れ等 異常なきこと No Damage
			4-1-2,4-1-3, 及び4-3-1~4-3-10の各項目を満足すること。 Must meet 4-1-2,4-1-3 and 4-3-1~4-3-10	
		手はんだ時 (Reflow by Manual Soldering iron) 端子先端、金具先端より0.2mmの位置まで、350±10°Cのはんだゴテにて3~4秒加熱する。但し、異常な加圧のないこと。 Using a soldering iron (350±10°C for 3~4 seconds) heat up the area 0.2mm from the tip of the solder tails and fitting nails. However, do not apply excessive pressure to either the terminals or fitting nails.	外 観 Appearance	端子ガタ、割れ等 異常なきこと No Damage

(): 参考規格 Reference Standard
{ }: 参考単位 Reference Unit

REVISE ON PC ONLY		TITLE:			
G	SEE SHEET 1 OF 20	Pico-Lock 1.0 W/B SINGLE-ROW R/A SMT GOLD PLATING 製品仕様書			
	REV.	DESCRIPTION	THIS DOCUMENT CONTAINS INFORMATION THAT IS PROPRIETARY TO MOLEX ELECTRONIC TECHNOLOGIES, LLC AND SHOULD NOT BE USED WITHOUT WRITTEN PERMISSION		
DOCUMENT NUMBER PS-503764-001		DOC. TYPE PS	DOC. PART 001	CUSTOMER GENERAL	SHEET 10 OF 20

【5. 外観形状、寸法及び材質 PRODUCT SHAPE, DIMENSIONS AND MATERIALS】

5-1. 製品寸法及び材質 Dimensions and materials of product.

図面参照 Refer to the drawing.

【6. 挿入力及び抜去力 INSERTION/WITHDRAWAL FORCE 】

極数 No of CKT	単位 UNIT	挿入力 (最大値) Insertion (MAX)			抜去力 (最小値) Withdrawal (MIN)		
		初回 1st	6回目 6th	30回目 30th	初回 1st	6回目 6th	30回目 30th
2	N {kgf}	15 {1.5}	15 {1.5}	15 {1.5}	0.7 {0.07}	0.7 {0.07}	0.7 {0.07}
3		15 {1.5}	15 {1.5}	15 {1.5}	1.1 {0.11}	1.1 {0.11}	1.1 {0.11}
4		15 {1.5}	15 {1.5}	15 {1.5}	1.5 {0.15}	1.5 {0.15}	1.5 {0.15}
5		15 {1.5}	15 {1.5}	15 {1.5}	1.9 {0.19}	1.9 {0.19}	1.9 {0.19}
6		15 {1.5}	15 {1.5}	15 {1.5}	2.3 {0.23}	2.3 {0.23}	2.3 {0.23}

※ロックを解除して測定 Released lock, and measure. { } :参考単位 Reference Unit

REVISE ON PC ONLY		TITLE:			
G	SEE SHEET 1 OF 20	Pico-Lock 1.0 W/B SINGLE-ROW R/A SMT GOLD PLATING			
		製品仕様書			
REV.	DESCRIPTION	THIS DOCUMENT CONTAINS INFORMATION THAT IS PROPRIETARY TO MOLEX ELECTRONIC TECHNOLOGIES, LLC AND SHOULD NOT BE USED WITHOUT WRITTEN PERMISSION			
DOCUMENT NUMBER PS-503764-001		DOC. TYPE PS	DOC. PART 001	CUSTOMER GENERAL	SHEET 11 OF 20

【 7. ピンアサイン PIN ASSIGNMENT 】

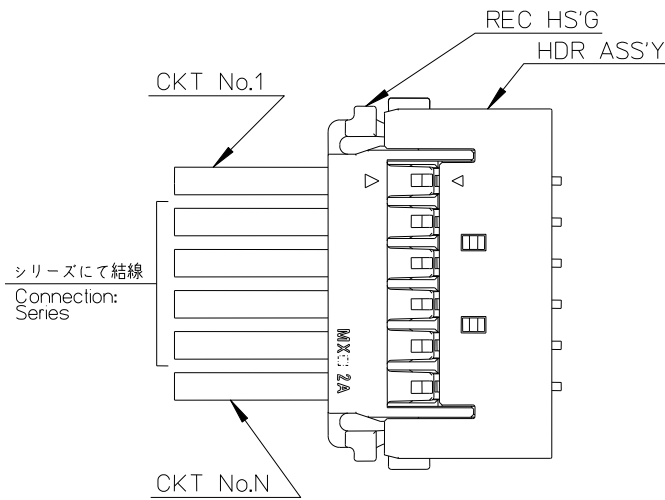

【 8. 接触抵抗測定箇所 CONTACT RESISTANCE MEASURING POINT 】

(コネクタの接触抵抗値は電線部分の導体抵抗値を除いております。)

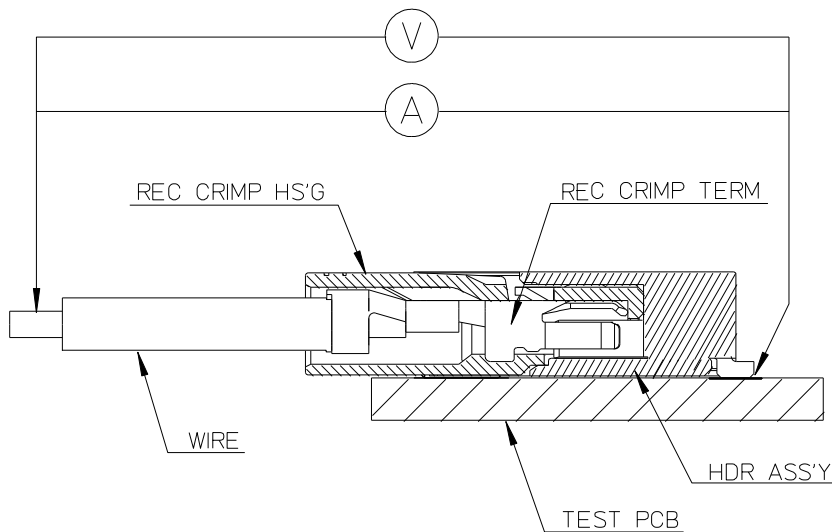

接触抵抗 : $m\Omega = V/A$

REVISE ON PC ONLY		TITLE: Pico-Lock 1.0 W/B SINGLE-ROW R/A SMT GOLD PLATING 製品仕様書			
G	SEE SHEET 1 OF 20				
REV.	DESCRIPTION	THIS DOCUMENT CONTAINS INFORMATION THAT IS PROPRIETARY TO MOLEX ELECTRONIC TECHNOLOGIES, LLC AND SHOULD NOT BE USED WITHOUT WRITTEN PERMISSION			
DOCUMENT NUMBER PS-503764-001		DOC. TYPE PS	DOC. PART 001	CUSTOMER GENERAL	SHEET 12 OF 20
EN-127(2015-12)					

【9. リフロー条件 REFLOW CONDITION】

リフロー回数 : 2回
Reflow times : Twice

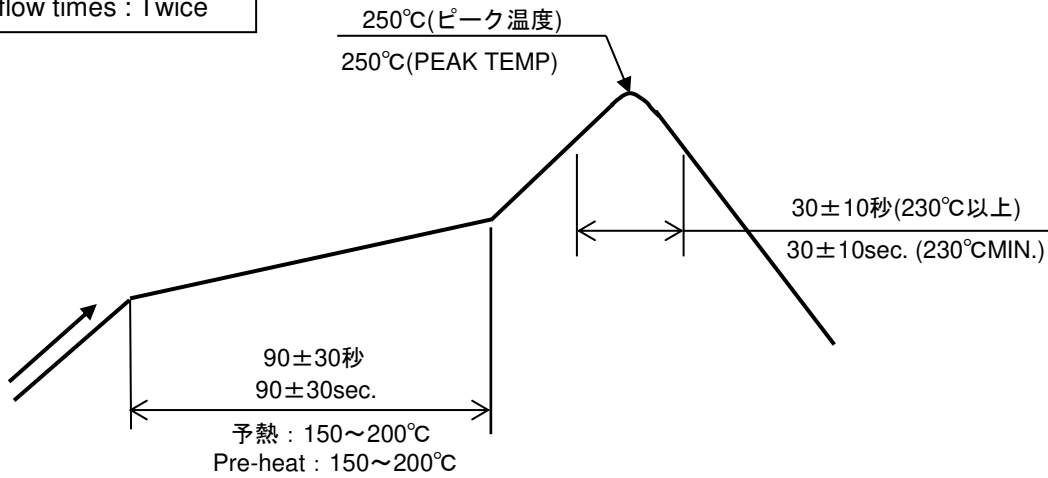

温度条件グラフ
TEMPERATURE CONDITION GRAPH
(はんだ接合部の基板表面にて測定)

(Temperature is measured at the soldering area on the surface of PWB)

注記 : 本リフロー条件に関しては、リフロー装置及び基板などにより条件が異なりますので
事前に実装評価(リフロー評価) の御確認を御願致します。
端子テール部、ネイル部が変色する場合がございますが、はんだ付け性には問題ありません。

NOTE : Please check the mount condition (reflow soldering condition) by your own devices
beforehand, because the condition changes by the soldering devices, printed wiring boards (PWB),
and so on. Although tail of terminal and nail may discolors, a solderability does not have a problem.

REVISE ON PC ONLY		TITLE:			
G	SEE SHEET 1 OF 20	Pico-Lock 1.0 W/B SINGLE-ROW R/A SMT GOLD PLATING			
	REV.	DESCRIPTION	THIS DOCUMENT CONTAINS INFORMATION THAT IS PROPRIETARY TO MOLEX ELECTRONIC TECHNOLOGIES, LLC AND SHOULD NOT BE USED WITHOUT WRITTEN PERMISSION		
DOCUMENT NUMBER PS-503764-001		DOC. TYPE PS	DOC. PART 001	CUSTOMER GENERAL	SHEET 13 OF 20

【 10. 注記 NOTES】

1. コネクタの嵌合を取り外す際は、かならずロックを解除して行ってください。
When connectors are unmated, positive locks shall be released.
2. 本製品のプラスチック部に黒点、気泡等が確認される場合や色合いが異なる場合（経年変化によるハウジングの変色を含む）が御座いますが、製品性能に影響は御座いません。
There is no influence in the product performance though the black spot or bubble etc. might be confirmed to the plastic part of this product and the shade might be different (discoloration by secular distortion etc).
3. 本製品のハウジング及びめっき表面に多少の傷が確認される場合がありますが、製品性能に問題御座いません。
A few scratches may be confirmed to the surface of the housing and the plating of this product, however, there is no problem in the product performance.
4. 本製品のプラスチック部が紫外線により変色する場合がありますが、製品性能には問題御座いません。
Discoloration of the plastic part of this product can result from exposure to ultraviolet light. There is no problem in the product performance.
5. 本製品を結露・水濡れが発生する環境でのご使用の場合は、適切な防滴処置をお願い致します。結露・水濡れにより、回路間で絶縁不良を起こす可能性が御座います。
When this product is used at a place where exposure to water could be expected, please handle with appropriate care to avoid damage from water. There is a possibility of causing insulated malfunction between the circuits.
6. 本製品を御使用の際には、定格以上の電流を複数の回路に分岐しての使用は避けてください。1回路当りの電流が計算上で定格を超えない様設計しても、導電路や接触抵抗のばらつきにより想定通りに1回路当りの電流が均等に分流されず、定格以上の通電により性能劣化が進行し、異常をきたすことにつながります。
When using this product, please ensure that the specification for rated current per circuit is followed. Do not allow the sum of the current used on several circuits to exceed the maximum allowable current.
7. コネクタの性能を損なう恐れがある為、コネクタの洗浄は、行わないでください。
Please do not conduct any washing process on the connectors because it may damage the product's function.
8. 本製品をご使用時に取り付けられた電線・プリント基板の共振や、機器の回転構造や可動部分の動作によりコネクタ嵌合部（接点部）が常に動いてしまう状態での御使用は避けてください。接触部の摺動磨耗等による接触不良の原因となります。従って、機器内で電線・プリント基板を固定し、共振を抑える等の処置をお願い致します。
Please do not use the connectors in a condition where the wire, PWB, or the contact area is experiencing a sympathetic vibration of wires and PWB, and constant movement of devices. This may cause a defect in the contact due to the contact area being worn down. Therefore, please fix wires and PWB on the chassis, and reduces sympathetic vibration.

REVISE ON PC ONLY		TITLE:			
G	SEE SHEET 1 OF 20	Pico-Lock 1.0 W/B SINGLE-ROW R/A SMT GOLD PLATING			
	REV.	DESCRIPTION	製品仕様書		
		<small>THIS DOCUMENT CONTAINS INFORMATION THAT IS PROPRIETARY TO MOLEX ELECTRONIC TECHNOLOGIES, LLC AND SHOULD NOT BE USED WITHOUT WRITTEN PERMISSION</small>			
DOCUMENT NUMBER PS-503764-001		DOC. TYPE PS	DOC. PART 001	CUSTOMER GENERAL	SHEET 14 OF 20
EN-127(2015-12)					

9. コネクタ嵌合状態で基板の持ち運び等コネクタに負荷が掛かる作業は行わないようにしてください。コネクタ破損等の原因となる場合が御座います。
Please do not do work that the load hangs in the connectors like the carrying of the substrate etc with the connectors engages. There is a case where it causes the connectors damage etc
10. 嵌合後、コネクタピッチ方向、スパン方向及び回転方向への負荷がかかるような動作またはセットはしないでください。コネクタ破壊やはんだクラックを引き起こします。
After mated the connectors, please do not allow the PWBs to apply pressure on the connectors in either the pitch direction, the span direction or rotational direction. It may cause damage to the connectors and may crack the soldering.
11. 本製品及び加工工程品（仕掛品）や加工品（ハーネス等）の梱包及び輸送・保管時にはコネクタに負荷が加わらないようご注意ください。変形、破損などの原因となり、コネクタの性能不良の原因となります。
Please try to prevent any external forces or shock from being applied to the connectors while the cable assembly is in process, when it is being packaged, or while it is in transportation. This may cause deformation and damage to the connectors and cause a defect in the product's performance.
12. 活電状態の電気回路で、挿入、抜去ができることを前提に作られておりません。スパーク等による危険の発生、性能不良につながりますので、活電状態での挿入、抜去はしないでください。
This product is not designed for the mating and unmating of the connectors to be performed under the condition of an active electrical circuit. It may cause a spark and product defect if the connectors are mated and unmated in this way.
13. コネクタに適用できる電線は、原則として錫めっき付軟銅撚り線です。その他の電線の使用については別途ご確認ください。
The applicable wire for this connectors, in principle, is tin-plated copper stranded wire. Please consult us and evaluate it in advance when using other wires.
14. コネクタに外力が加わらないようにクリアランスをあけた筐体構造にしてください。
Please keep enough clearance between connectors and chassis of your application in order not to apply pressure on the connectors.
15. 電線の結束はコネクタから35 mm以上のところで、電線に加わる力が均一になるようにしてください。ハーネス品で電線一本（又は特定の数本）に力が加わらない様にしてください。
Please tie the cable at least 35 mm away from the edge of the connectors and try to ensure that the force is applied evenly on all of the wires.
16. 治具等を使用して圧着端子を抜いた場合には、ランスが変形し強度が低下し端子を再装着後の端子保持力が極端に低下します。そのため、圧着端子のリペアの際には新しいハウジングを必ず使用してください。
When extracting a crimp terminal from the housing using a jig, it may deform the housing lance and therefore reduce the terminal retention force enormously after re-inserting of the terminal. Therefore, please ensure to use a new housing after repairing the crimp terminals.

REVISE ON PC ONLY		TITLE:			
G	SEE SHEET 1 OF 20	Pico-Lock 1.0 W/B SINGLE-ROW R/A SMT GOLD PLATING			
	REV.	DESCRIPTION	製品仕様書		
		<small>THIS DOCUMENT CONTAINS INFORMATION THAT IS PROPRIETARY TO MOLEX ELECTRONIC TECHNOLOGIES, LLC AND SHOULD NOT BE USED WITHOUT WRITTEN PERMISSION</small>			
DOCUMENT NUMBER PS-503764-001		DOC. TYPE PS	DOC. PART 001	CUSTOMER GENERAL	SHEET 15 OF 20
EN-127(2015-12)					

17. ハーネス加工品及びコネクタ嵌合後の電線の引き回しの際、引張りによる力が加わりますと、接点部、結線部（圧着部）やロック部（端子ロック部）が損傷を受け、接触不良の原因となります。電線の引回し配線をされる場合、コネクタに無理な外力が加わらないように、電線に緩みを持たせ、余裕を持たせる処置をしてください。
The cable assembly should not have a constant stress or pulling force applied on it when it is in the mated condition. This phenomenon may damage the contact area or wiring area (crimping). Therefore, when designing the wire positioning, please ensure that there is enough length of wire to avoid stress on the connectors.
18. コネクタの詳細な取り扱いにつきましては、別紙の1.0 W/B CONNのコネクタ取り扱い説明書 [AS-503764-001]を参照してください
Please refer to the manual of the 1.0 W/B connector series for the detailed handling of the connector[AS-503764-001]
19. 嵌合時図1にリセハウジングの矢印で示す部位を押し嵌合してください。電線で押した場合、これらが破損する恐れがありますのでお避けください。
Please push the part directed by FIG1 at the time of mate.
It may damage, when electric wires of the receptacle housing are pushed.



図 1
FIG 1

20. 引き抜く時図2に示すように、電線はまとめて軽くつかみ、リセプタクルハウジングのロックに指を添え、指の平を用いて、ロック解除用バーを押してロックを完全に解除してから、ゆっくり、軸方向にまっすぐに引き抜いてください。また、斜めにこじりながら抜くことは避けてください。コネクタを破損させる恐れが御座います。
When unmating the connector, as FIG 2 shows, please hold wires all together lightly. After releasing lock completely by attaching fingers to the lock and pushing bar for releasing lock using flat part of finger, please withdraw receptacle housing slowly, axially and straightly. Please avoid withdrawing them with an angle and roughly. That might cause damage to connector.

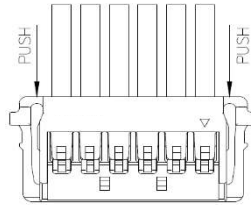

図 2
FIG 2

REVISE ON PC ONLY		TITLE:			
G	SEE SHEET 1 OF 20	Pico-Lock 1.0 W/B SINGLE-ROW R/A SMT GOLD PLATING			
	REV.	DESCRIPTION	THIS DOCUMENT CONTAINS INFORMATION THAT IS PROPRIETARY TO MOLEX ELECTRONIC TECHNOLOGIES, LLC AND SHOULD NOT BE USED WITHOUT WRITTEN PERMISSION		
DOCUMENT NUMBER PS-503764-001		DOC. TYPE PS	DOC. PART 001	CUSTOMER GENERAL	SHEET 16 OF 20
EN-127(2015-12)					

21. 圧着高さ、状態、適用電線等の詳細は、弊社圧着仕様書(ATS)を参照願います。
The details refer to our Application Tooling Specification Sheet(ATS), such as crimping satisfied height, state and applicable wire.
22. 嵌合後、コネクタピッチ方向、スパン方向及び回転方向への負荷がかかるような動作またはセットはしないでください。コネクタ破壊やはんだクラックを引き起こします。
After mating, please do not take a connector pace direction, a span direction and load to the rotator direction. It causes connector destruction and the solder crack.
- 23.ハウジングのロック部やランス部などの可動部、及び端子を故意に変形させないでください。製品性能が満足出来ない原因となります。
Do not deform the movable part as lock part and lance part of Plug HS'G and terminals on purpose. It would lead to product failure.
24. はんだ実装部の未はんだは、ターミナル脱落、ピン間ショート、ターミナル座屈、またコネクタ基板からの外れが懸念されます。従って全てのターミナルテール部及び、ネイル部にはんだ付けを行ってください。
If you leave any soldering area on this product open, there may be the possibility of a missing terminal short circuiting between pins, terminal buckling or the potential for the connectors to come off of the PWB. Therefore, please solder all of the terminals and fitting nails on the PWB.
25. 実装機によってコネクタに負荷が加わると変形、破損する場合がありますので事前にご確認ください。
If there is accidental contact with the connectors while it is going through the reflow machine, there may be deformation or damage caused to the connectors. Please check to prevent this
26. 実装性能（平坦度）は、実装基板の反りの影響を含まないものと致します。
The mounting specification for coplanarity does not include the influence of warpage of the PWB.
27. 基板実装前後に端子及びネイルに触らないでください。
Please do not touch the terminals and fitting nails before or after mounted the connectors onto the PWB.
28. 基板実装後に基板を直接積み重ねない様に注意してください。
Please do not stack the PWB directly after mounted the connectors on it.
29. 実装後において手はんだコテによるリペアを行なう際は、必ず仕様書掲載の条件以内で行なってください。条件を超えて実施した場合、端子の抜け、接点ギャップの変化、モールドの変形、溶融等が原因により破損の原因になります。
Please conduct it under the condition of the specifications when repairing by hand soldering iron after mounting. In the case of practicing beyond the condition, the backlash, the change in the contact gap, the deformation of the mold and the melting, etc may cause damage.
30. コネクタのみで基板を支えることは避け、コネクタ以外での基板固定対策を行ってください。
Please do not use the connectors alone to provide mechanical support for the PWB. Please ensure that there is a fixed structure on the phone chassis or other component support for the PWB.

REVISE ON PC ONLY		TITLE:			
G	SEE SHEET 1 OF 20	Pico-Lock 1.0 W/B SINGLE-ROW R/A SMT GOLD PLATING			
	REV.	DESCRIPTION	製品仕様書		
		<small>THIS DOCUMENT CONTAINS INFORMATION THAT IS PROPRIETARY TO MOLEX ELECTRONIC TECHNOLOGIES, LLC AND SHOULD NOT BE USED WITHOUT WRITTEN PERMISSION</small>			
DOCUMENT NUMBER PS-503764-001		DOC. TYPE PS	DOC. PART 001	CUSTOMER GENERAL	SHEET 17 OF 20
EN-127(2015-12)					

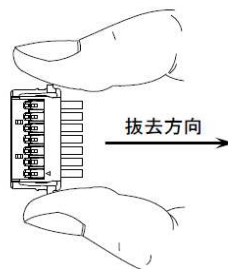
- 31. 本製品の平坦度については、実装前での保証のみであり、実装中および実装後での平坦度については、保証の限りではありません。
Coplanarity is assured only before mounting.
There is no guarantee of coplanarity after mounting and in the reflow.
- 32. 弊社の推奨基板パターン寸法を変更して設計を行なう際は、致命的な不良の原因にもなりますのであらかじめご相談ください。
In the case of changing our recommended board pattern size and designing, please consult in advance because it may cause a fatal defect.
- 33. 本品の一般性能確認はガラスエポキシ基板にて実施していますので、フレキシブル基板等の特殊な基板へ実装してご使用の際は、別途ご相談願います。
It is necessary to consult separately when mount product on a special PWB or FPC.
- 34. リフロー条件によっては端子めっき部にヨリ等が発生する場合がありますが、製品性能には影響ありません。
There is no influence in the product performance though the twist might be generated in the terminal plating part according to the reflow condition.
- 35. リフロー条件によっては樹脂部に変色が発生する場合がありますが、製品性能には影響ありません。
There is no influence in the product performance though discoloration might be generated in the resin according to the reflow condition.
- 36. リフロー後、はんだ付け部に変色が見られることがありますが、製品性能に影響はありません。
Although there might be some discoloration seen on the soldering tail after reflow, this will not influence the product's performance.
- 37. 本製品は赤外線リフローでの実装を想定しています。N2リフローで実装した場合、リフロー後、はんだ上がりを生じる恐れがあります。N2リフローでの実装をお考えの場合、別途評価が必要になります。Please investigate the mounting condition (reflow soldering condition) on your own devices beforehand. The mounting conditions may change due to the soldering temperature, soldering paste, IR reflow machine, Nitrogen reflow machine, and the type of PWB. The different mounting conditions may have an influence on the product's performance.
- 38. 弊社評価では厚さ0.1mm、開口率100%のメタルマスクを使用しています。
Thickness 0.1mm, aperture ratio 100% stencil is used in this specification.

REVISE ON PC ONLY		TITLE: Pico-Lock 1.0 W/B SINGLE-ROW R/A SMT GOLD PLATING 製品仕様書			
G	SEE SHEET 1 OF 20				
REV.	DESCRIPTION	THIS DOCUMENT CONTAINS INFORMATION THAT IS PROPRIETARY TO MOLEX ELECTRONIC TECHNOLOGIES, LLC AND SHOULD NOT BE USED WITHOUT WRITTEN PERMISSION			
DOCUMENT NUMBER PS-503764-001		DOC. TYPE PS	DOC. PART 001	CUSTOMER GENERAL	SHEET 18 OF 20
EN-127(2015-12)					

39. 本製品のハウジング材料は耐熱性ポリアミドを使用しており、ハウジングの吸水状態、或いは、はんだ付け条件によっては、リフローはんだ付け時にハウジング表面に「ふくれ」が発生する可能性があります。この「ふくれ」に関しましては、ポリアミド材の物性変化を伴うものではなく、製品機能を損なうものではありません。

The housing material of this product is made from a high heat resistant Polyamide. The soldering condition and the water absorption properties of the housing material may cause blistering on the housing surface. Because this blister is not caused by property change, it does not damage the product's features.

40. 本製品のリセプタクルハウジング材料はポリアミドを使用しており、吸水状態によって挿抜力・挿入感が変わります。過度な吸水により、挿入時に嵌合相手と若干干渉する場合や、クリック感が弱くなる場合がありますが、製品性能、機能には問題ございません。

Because the receptacle housing material of this product is using Polyamide, the water absorption status of the housing material might change insertion force, withdrawal force, or the feeling of insertion. Its excessive water absorption may cause to interfere with insertion a little bit or to weaken the click feeling of the lock when mating. However it does not damage the product's features and functions.

REVISE ON PC ONLY		TITLE:			
G	SEE SHEET 1 OF 20	Pico-Lock 1.0 W/B SINGLE-ROW R/A SMT GOLD PLATING			
	REV.	DESCRIPTION	THIS DOCUMENT CONTAINS INFORMATION THAT IS PROPRIETARY TO MOLEX ELECTRONIC TECHNOLOGIES, LLC AND SHOULD NOT BE USED WITHOUT WRITTEN PERMISSION		
DOCUMENT NUMBER PS-503764-001		DOC. TYPE PS	DOC. PART 001	CUSTOMER GENERAL	SHEET 19 OF 20
EN-127(2015-12)					

製品仕様書

