

LOC		DIST		REVISIONS			
F	LTR	DESCRIPTION	DATE	DWN	APVD		
A1		ECR-11-002167	31JAN11	JvdHTdB			

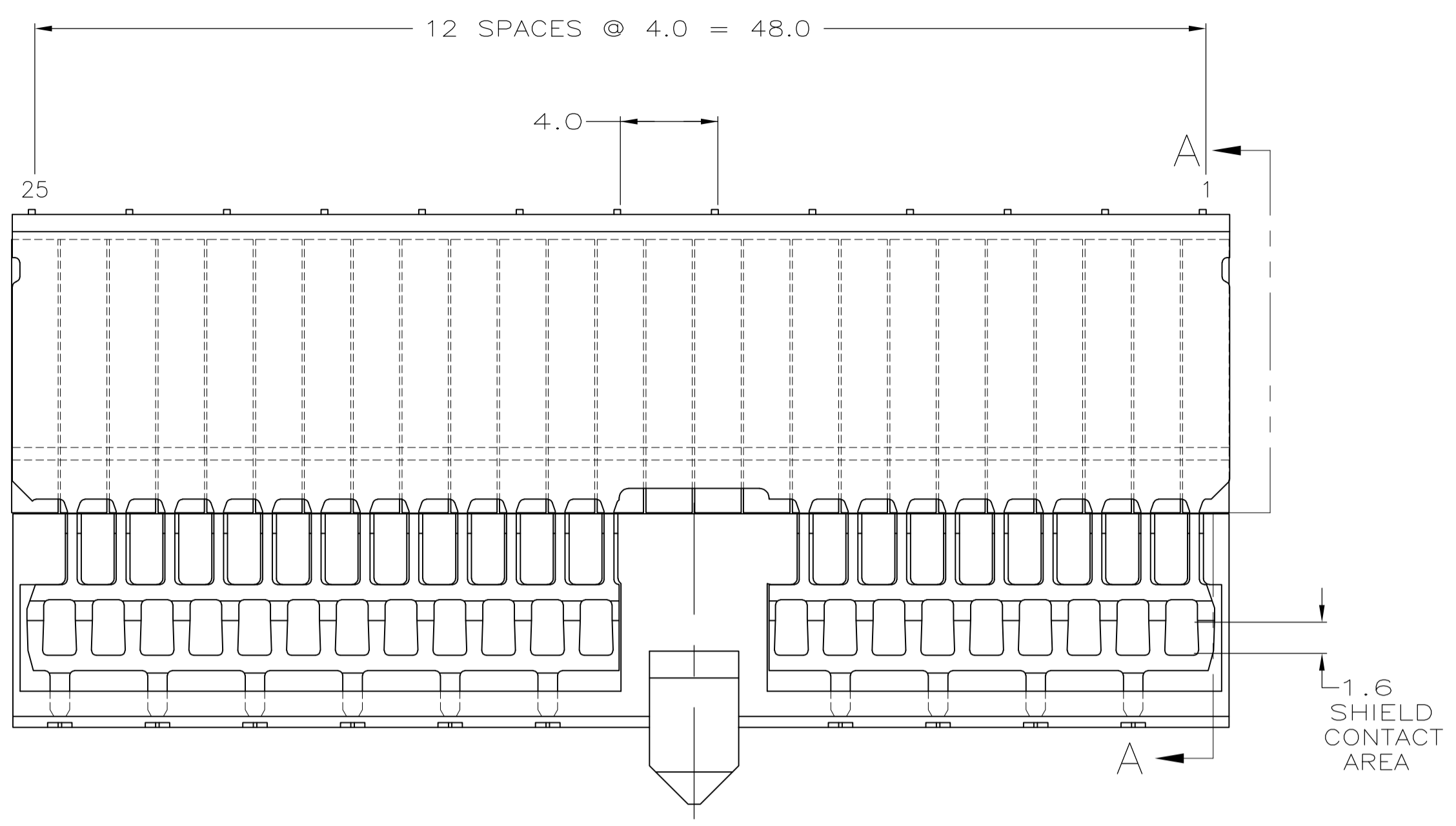

- 1 MATERIAL:  
CONTACT: PHOSPHOR BRONZE.  
HOUSING: GLASS-FILLED POLYESTER.
- 2 GENERAL PLATING SPECIFICATION: UNDERPLATING  
(ENTIRE CONTACT): 1.27µm MIN NICKEL AND ACTION  
PIN: 0.5µm MIN TIN.  
FOR PLATING OF MATING SURFACES SEE APPLICABLE SPECIFICATION REFERENCE FOR EACH DASH NUMBER.
- 3 CONFORMS TO ALL TESTING ACCORDING TO IEC 61076-4-101 PERFORMANCE LEVEL 2.
- 4 CONFORMS TO ALL TESTING ACCORDING TO IEC 61076-4-101 PERFORMANCE LEVEL 1.
- 5 CONNECTOR TESTED AND QUALIFIED AGAINST TELCORDIA GR-1217-CORE QUALITY LEVEL 3, CENTRAL OFFICE APPLICATIONS.
- 6 CONNECTOR TESTED AND QUALIFIED AGAINST TELCORDIA GR-1217-CORE QUALITY LEVEL 3, UNCONTROLLED ENVIROMENT APPLICATIONS.
- 7 CONNECTOR MARKED WITH PART NUMBER AND DATE CODE. ADDITIONAL CHARACTERS OR MARKINGS, AS WELL AS THE LOCATION OF THE MARKINGS, MAY BE ADDED FOR TRACEABILITY BASED UPON MANUFACTURERS DISCRETION.
- 8 PLATED-THROUGH HOLES AT 2x2mm SQUARE GRID PATTERN DEFINED BY CONTACT LAYOUT.
- 9 CONNECTOR LUBRICATED WITH BELCORE APPROVED LUBRICANT, TECHNICAL REFERENCE: TR-NWT-001217 ISSUE 1, SEP 1992.
- 10 13 PLATED THROUGH HOLES FOR UPPER SHIELD, ROW F.
- 11. SHIELD MOUNTED TO CONNECTOR WITH DOUBLE SIDED ADHESIVE TAPE OR ADHESIVE.

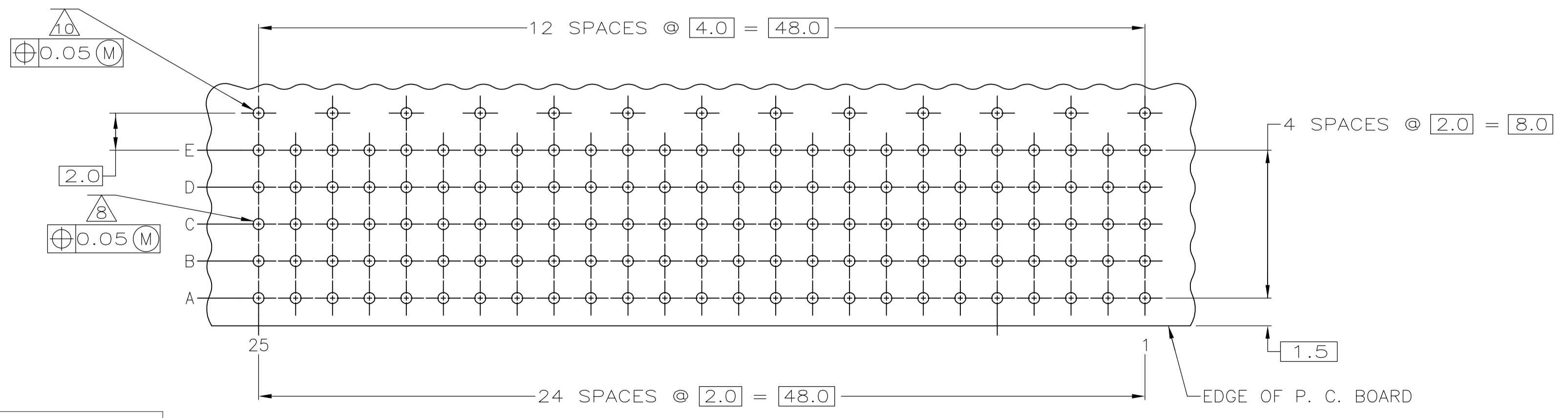
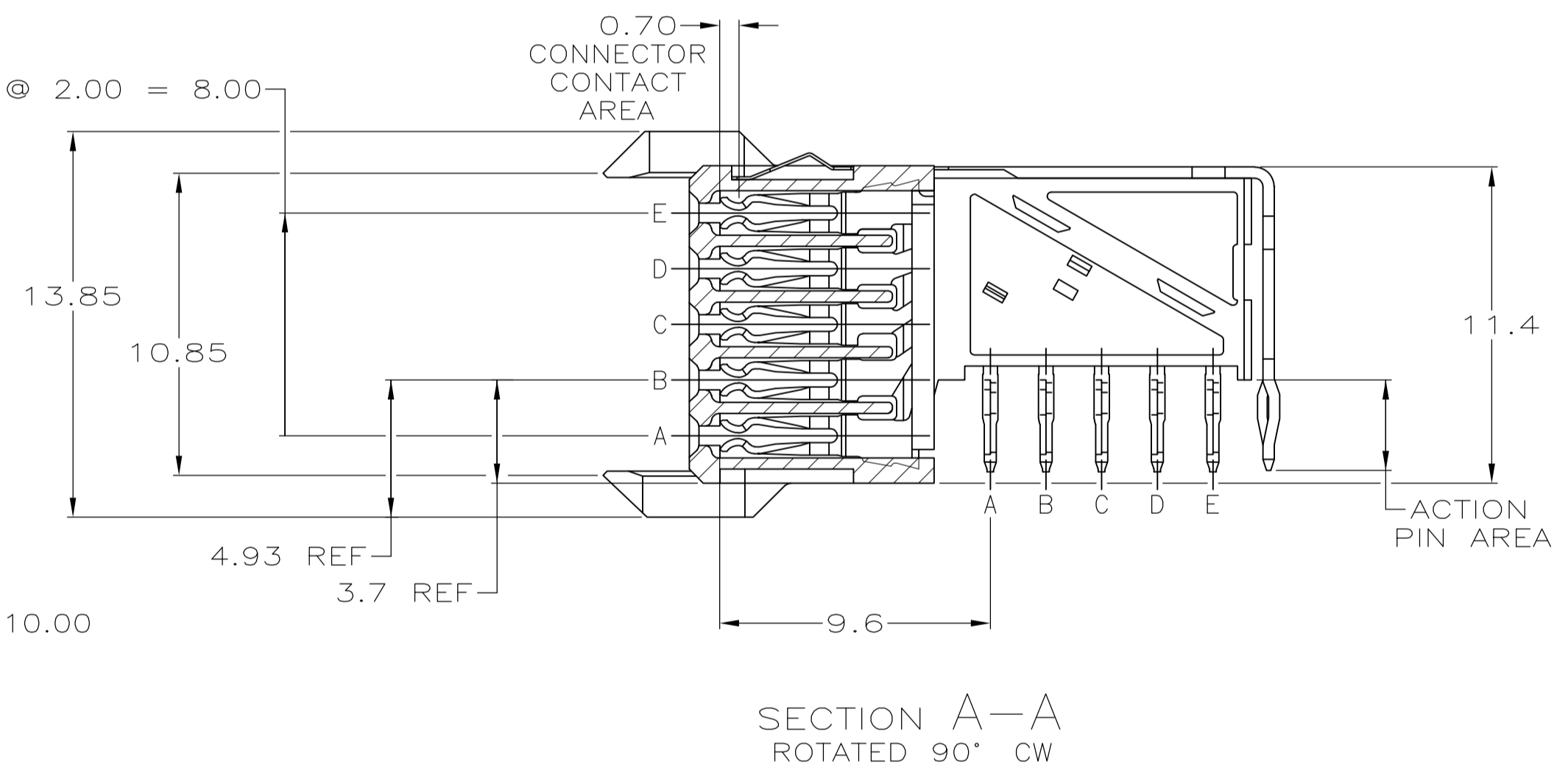
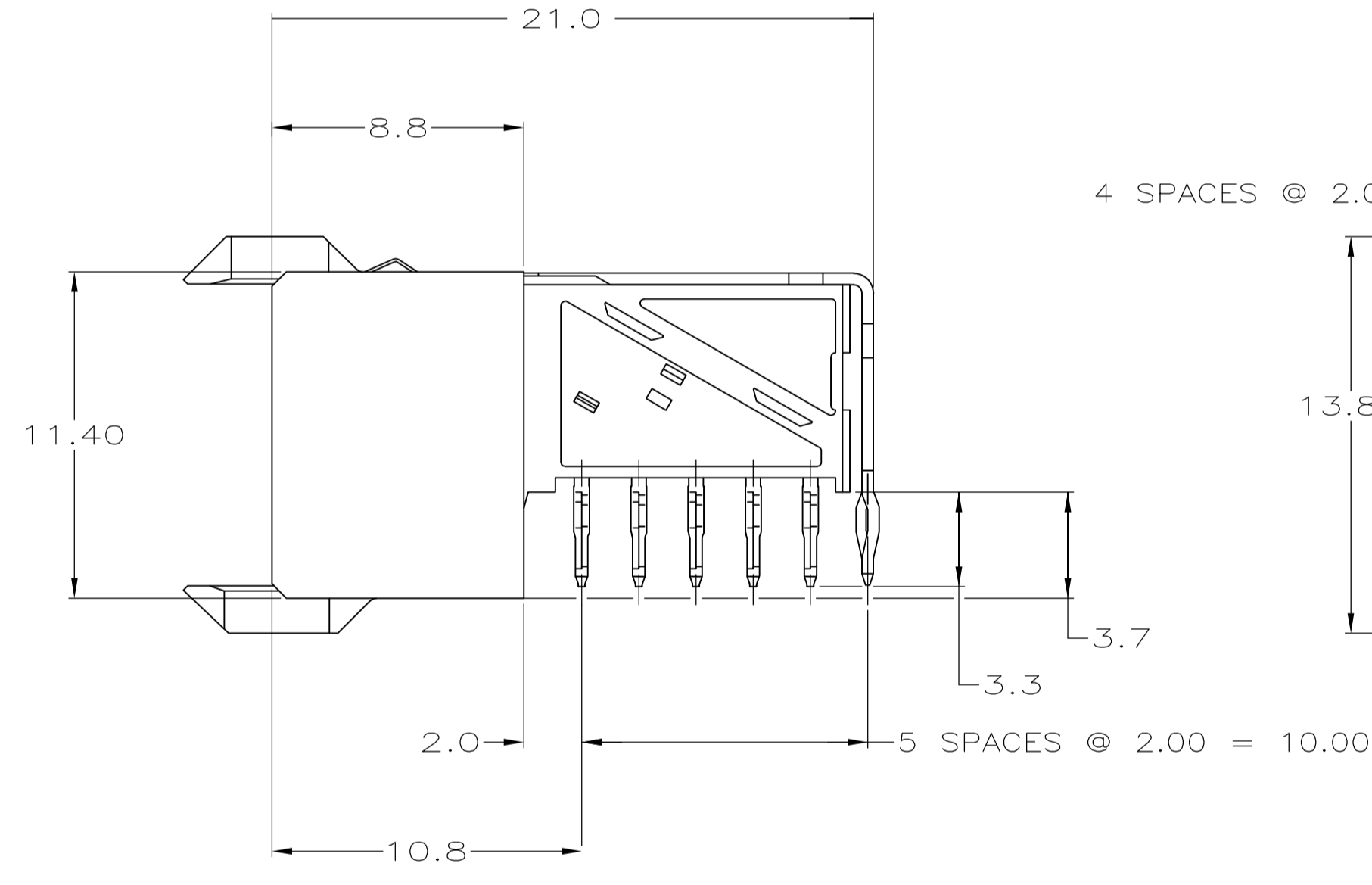
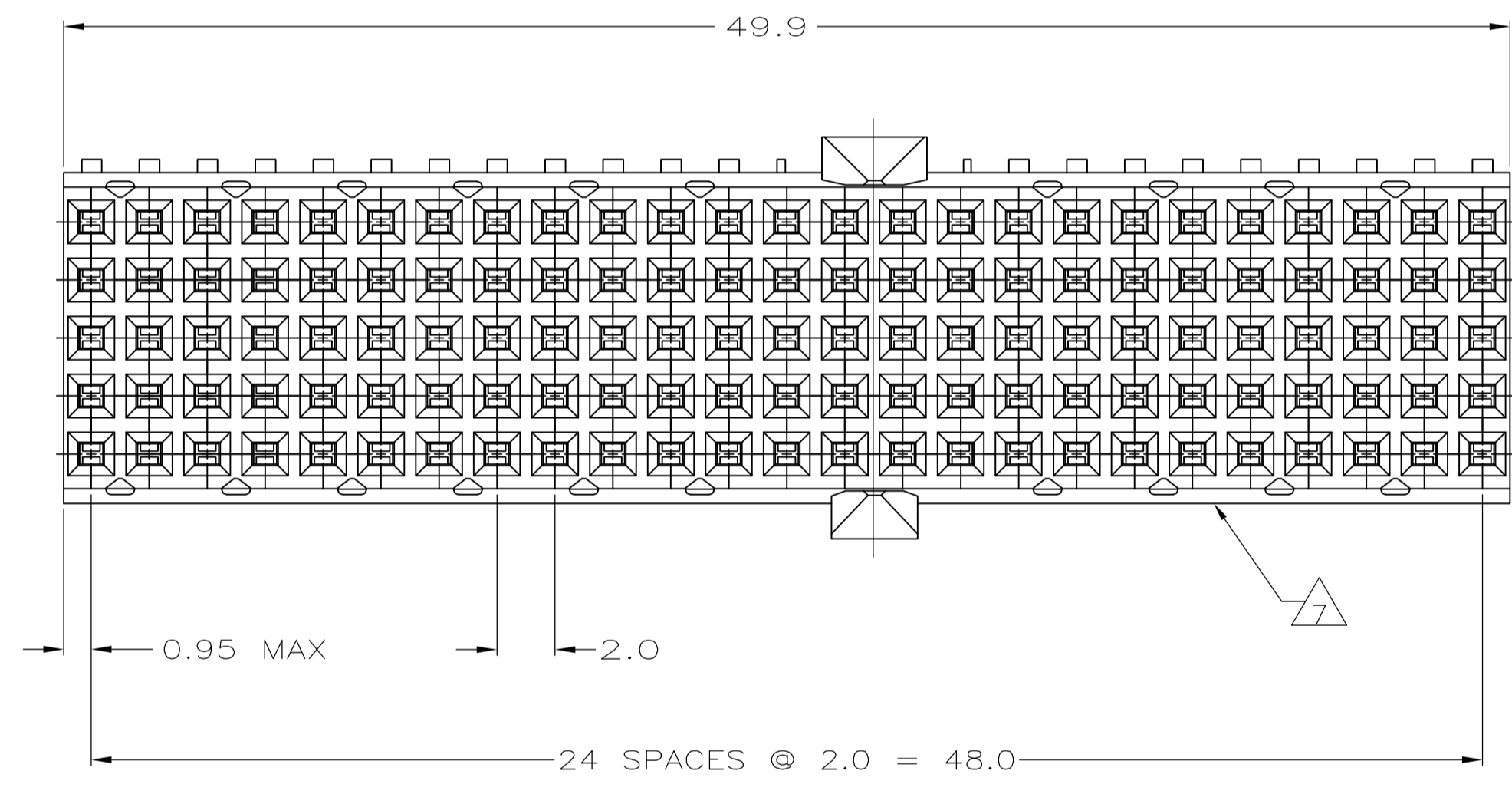

PLATED THRU HOLES PARAMETERS  
 REFERENCE APPLICATION SPECIFICATION

RECOMMENDED PCB-HOLE LAYOUT  
 COMPONENT SIDE SHOWN  
 SCALE 2.5:1

2 6 9	1-1551495-9
2 5 9	1551495-9
2 4 4	1551495-4
2 3 3	1551495-1
FINISH	PART NUMBER

THIS DRAWING IS A CONTROLLED DOCUMENT.		DIN B.MOOIJ 25NOV09	Tyco Electronics Corporation 's-Hertogenbosch, Nederland	
DIMENSIONS: mm		CIK R.VERBEET 26NOV09	NAME	
TOLERANCES UNLESS OTHERWISE SPECIFIED:		T.D.F. BOER 27NOV09	RECEPTACLE ASSEMBLY, Z-PACK 2mm HM, TYPE A/B25, PRE-SHIELDED, 125 POSITION WITH OFFSET POLARIZATION	
0. PLC ± -		PRODUCT SPEC	108-19082	
1. PLC ± 0.2		APPLICATION SPEC	114-19029	
2. PLC ± 0.05		SIZE	CAGE CODE	DRAWING NO
3. PLC ± -		WEIGHT	A1	00779
4. PLC ± -		CUSTOMER DRAWING	SCALE	5:1
ANGLES ± -		SHEET	1	OF 1
FINISH SEE TABLE		REV	A1	